

Self Propelled Sprayer



CROPLANDS
www.croplands.com.au



SALES AND SUPPORT

Croplands Australia

Tel.....1800 999 162

Fax1800 623 778

Email.....sales@croplands.com.au

CROPLANDS BARGAM

PRODUCT LEAD AUS/NZ

Dave Farmer.....0427 651 971



IDEAL FOR VEGETABLE AND ROW CROPS



Rops cab with pneumatic main seat and passenger seat



Ground clearance 1580mm standard



Bolted wheel motor mounts



Console

CURRENT FEATURES

- "FPT N67" TIER 4B/STAGE IV 6 CYLINDERS ENGINE. RATED POWER: 151 kW (205 hp) AT 2200 RPM. MAX POWER: 165 kW (224 hp) AT 1800 RPM
- HYDROSTATIC TRANSMISSION (FIELD: 0-25 km/h; ROAD: 0-40 km/h) WITH 4 POCLAIN WHEEL MOTORS (MS11 ON FRONT WHEELS AND MS18 ON REAR WHEELS) ELECTRONIC CONTROL AND AUTOMATIC TRANSMISSION
- 4 WHEEL DRIVE
- "SRS" ANTISKID SYSTEM ENSURES POWER TO THE GROUND IN CHALLENGING CONDITIONS
- HYDRAULIC 4 WHEEL STEERING SYSTEM (2WS / 4WS / CRAB). ELECTRONIC WHEEL REALIGNMENT AND CORRECTION
- GROUND CLEARANCE 1580 mm WITH WHEELS 300/95 R46
- PANORAMIC ROPS CAB WITH INSTRUCTOR SEAT, ELECTRONIC 6 VENT CLIMATE CONTROL (EN 15695-1 CAT. 4) WITH AIR FILTER
- STEREO WITH MEDIA PLAYER (MP3, USB, SD), REMOTE CONTROL AND BLUETOOTH HANDSFREE
- REFRIGERATED COMPARTMENT

- TRIPLE NOZZLE BODIES AT 50CM NOZZLE SPACING
- PARALLELOGRAM HYDRAULIC BOOM HEIGHT ADJUSTMENT, STROKE 1900
- MULLER "B" TOUCH 800 (8" TOUCH SCREEN) AUTOMATIC RATE CONTROLLER
- 5 SECTION BOOM ON 18/21M WIDTHS
- 7 SECTION BOOM ON 24-36M WIDTHS
- 35l CHEMICAL INDUCTION HOPPER
- 250 l/min DIAPHRAGM PUMP FOR SPRAYING AND AGITATION
- QUICK FILL POINT FOR TANK FILLING
- WHEELS: 300/95 R46
- HYDRAULIC LADDER

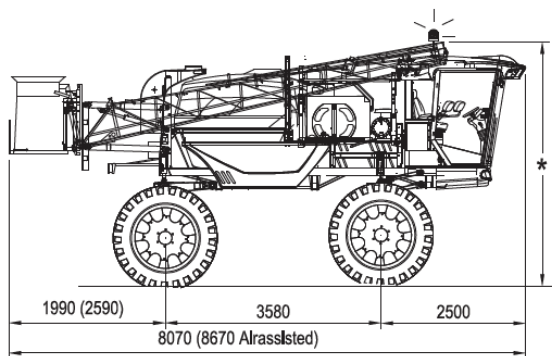

KG = 8500/9500 = 250/400

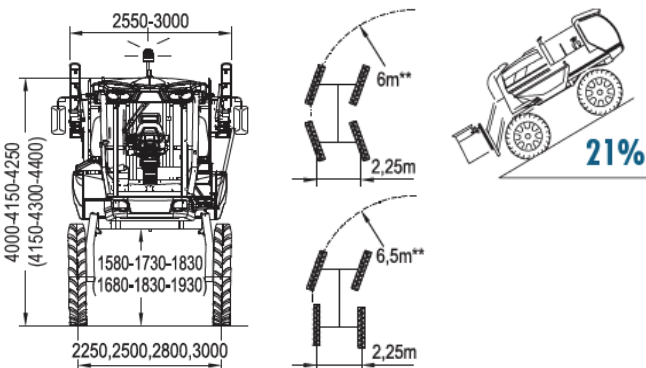

OPTIONAL FEATURES

- Airassisted Boom with single or dual fans
- GPS Compatible to most brands
- Boom Stabilising Kit
- Equipment Washing Spray Gun
- Electronic tank filling litre-counter
- Hydraulic hose reel
- Cylinder for machine lifting
- Hydraulic track widening
- Self priming pump
- Pump for agitation
- Colour camera
- Lubrication system
- Led working light on the boom
- In cab electronic boom flush
- Water system with pneumatic pressure regulation valve (pneumatic-control jets)
- 2-3m Hydraulic Adjustable wheel track

AIRASSISTED BOOM

- Optimal air-liquid distribution system
- Increases coverage enabling the operator to reduce water rates in most situations
- Large operating range

