

Self Propelled Sprayer



CROPLANDS
www.croplands.com.au



SALES AND SUPPORT

Croplands Australia
Tel.....1800 999 162
Fax1800 623 778
Email.....sales@croplands.com.au

CROPLANDS BARGAM
PRODUCT LEAD AUS/NZ
Dave Farmer.....0427 651 971



IDEAL FOR VEGETABLE AND ROW CROPS

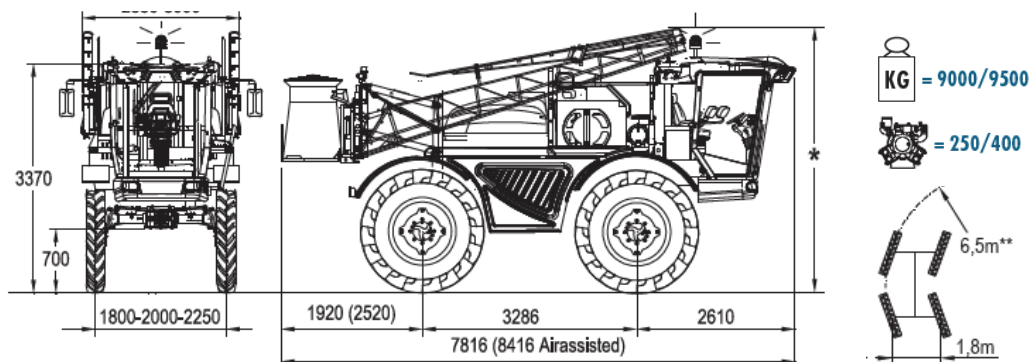

CURRENT FEATURES

- 6 CYLINDERS ENGINE. RATED POWER: 151 kW (205 hp) AT 2200 RPM. MAX POWER: 165 kW (224 hp) AT 1800 RPM
- FOUR WHEEL DRIVE MECHANICAL TRANSMISSION WITH DANA DIFFERENTIAL AND 2 MECHANICAL SPEED
- DANFOSS HYDROSTATIC TRANSMISSION (FIELD: 0-25 km/h; ROAD: 0-40 km/h) WITH PROPORTIONAL DISPLACEMENT MOTORS AND PUMP WITH ELECTRONIC CONTROL.
- HYDRAULIC 4 WHEEL STEERING SYSTEM (2WS / 4WS / CRAB). ELECTRONIC WHEEL REALIGNMENT AND CORRECTION.
- DIFFERENTIAL REAR WHEEL LOCK
- GROUND CLEARANCE 700 mm
- PANORAMIC ROPS CAB WITH INSTRUCTOR SEAT, ELECTRONIC
- 6 VENT CLIMATE CONTROL (EN 15695-1 CAT. 4) WITH AIR FILTER
- STEREO WITH MEDIA PLAYER (MP3, USB, SD), REMOTE CONTROL AND BLUETOOTH HANDSFREE
- REFRIGERATED COMPARTMENT

- TRIPLE NOZZLE BODIES AT 50CM NOZZLE SPACING
- ELECTRIC OVER HYDRAULIC FOLDING BOOM WITH JOYSTICK CONTROL
- MULLER "B" TOUCH 800 (8" TOUCH SCREEN) AUTOMATIC RATE CONTROLLER
- 5 SECTION BOOM ON 18/21M WIDTHS
- 7 SECTION BOOM ON 24-36M WIDTHS
- 351 CHEMICAL INDUCTION HOPPER
- 250 l/min DIAPHRAGM PUMP FOR SPRAYING AND AGITATION
- QUICK FILL POINT FOR TANK FILLING
- WHEELS: 300/95 R46 WITH BOLTED FLANGE
- 3 FIXED TRACK POSITIONS (REVERSING THE WHEELS OR CHANGING FLANGES) 1800 - 2000 - 2250 mm
- DIFFERENT TRACK WIDTHS AVAILABLE BY CHANGING TYRE SIZE OR RIM OFFSET

* = variable depending on the type of boom

** = with standard wheels

OPTIONAL FEATURES

- Airassisted Boom with single or dual fans
- GPS Compatible to most brands
- Boom Stabilising Kit
- Equipment Washing Spray Gun
- Electronic tank filling litre-counter
- Hydraulic hose reel
- Cylinder for machine lifting
- Self priming pump
- Pump for agitation
- Colour camera
- Lubrication system
- Led working light on the boom
- In cab electronic boom flush
- Water system with pneumatic pressure regulation valve (pneumatic-control jets)



Electronically operated feed pump kit



Console



Rops cab with pneumatic main seat and passenger seat



Axle

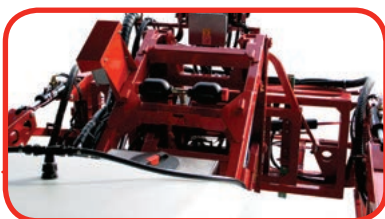

Accumulator boom suspension



AIRASSISTED BOOM

- Optimal air-liquid distribution system
- Increases coverage enabling the operator to reduce water rates in most situations
- Large operating range

