

CROPLANDS

Pegasus



Parts & Operator's Manual

Foreword

Important Information

Section 1

Pre-Operation

Section 2

Sprayer Operation

Section 3

Sprayer Calibration

Section 4

Lubrication & Maintenance

Section 5

Trouble Shooting

Section 6

Assembly Drawings & Parts Listings

Section 7

Foreword

About This Manual

This manual provides assembly, setting up, operating and maintenance instructions for the Croplands Pegasus sprayer.

Some features explained in this manual may not be installed on your sprayer.

Please pass on this manual with the sprayer at the time of resale for usage by the new owner.

Terminology

These terms/symbols used throughout this manual:

- **NOTE** - to convey useful operating information.
- **CAUTION** - to highlight potential injury or machinery damage.
- **WARNING** - to stress potential dangers and the importance of personal safety.

NOTE

Refers to important and useful information which should not be overlooked.

CAUTION

Highlights hazards, unsafe/unwise practices which could cause injury, damage to property, machinery or loss of crop yield if instructions are not followed.

WARNING

Indicates the strong possibility of severe personal injury or damage to machinery if instructions are not followed.

Before Operating Your Sprayer

- 1 Before attempting to use your sprayer, make sure you **read the Operator's Manual** and properly understand:
 - All Safety Issues.
 - Assembly & Installation instructions.
 - Calibration of the sprayer.
 - Sprayer Operation.
 - Sprayer Maintenance.
- 2 Read and follow instructions on chemical manufacturers' labels.
- 3 Always wear applicable protective clothing.



Read and understand this Operators' Manual before operating the sprayer.



Introduction	1.2
General Specifications	1.3
Your Sprayer's Specifications	1.4
Shipping Information & Product ID	1.5
Warranty Policy	1.6
Pre-Delivery Check List	1.7
Warranty Registration	1.9



Sean Mulvaney, General Manager of Croplands

Congratulations on the purchase of your new Croplands sprayer.

Croplands have been in the business of building and selling spraying equipment since 1972. For over 40 years we have been supplying sprayers to farmers, contractors, growers and all our customers involved in growing crops and in the control of pests and diseases.

Croplands is a wholly owned subsidiary of Nufarm Ltd, the largest supplier of crop protection chemicals in Australasia, and one of the fastest growing global suppliers world-wide.

At Croplands, we pride ourselves on our commitment to supplying machinery that is at the forefront of the industry's needs. We believe we can back up our products and through constant research and development, bring to you the best equipment you can find.

We welcome any feedback from you about our equipment.

On this page you will find our contact details, and locations where our staff can be reached during business hours.

After hours, you can e-mail us and expect a reply the following morning.

Please read this manual in its entirety before you operate your sprayer. This will ensure you have a trouble-free start up.

In this manual you will find the parts listings you need should you have any breakdowns in the future.

Bear in mind that over time, some parts may become obsolete or be replaced with better options. You can contact us for alternative options if this is the case.

We trust you will get years of good use from your Croplands Sprayer.

Yours sincerely

Sean Mulvaney
General Manager

Contact details:

AUSTRALIA

Croplands Equipment Pty Ltd
ACN 006 450 184
PO Box 2441, Dry Creek
50 Cavan Road, Dry Creek
S.A. 5094
Australia

FreePhone: 1800 999 162

FreeFax: 1800 623 778

e-mail: sales@croplands.com.au

website: www.croplands.com.au

NEW ZEALAND

Croplands Equipment Ltd
PO Box 2004,
Stotford Lodge, Hastings 4120
Location:
1422 Omahu Road,
Hastings 4120, New Zealand

FreePhone: 0800 106 898

FreeFax: 0800 117 711

e-mail: sales@croplands.com.au

website: www.croplands.com.au



6000 litre Pegasus with 20.8 x 42 single wheels.

General Description & Specifications

Tank

4000, 5000 or 6000 litre polyethylene tank with hinged lid, filling strainer, top/bottom fill point, large sump with drain, dual agitators, direct chemical induction & tank rinsing jet. Calibrated sight gauge fitted. UV and chemical resistant finish.

Chassis

Strong, fabricated wide-rail chassis, fully welded for maximum strength. Standard with solid fixed-width axle. Adjustable-height drawbar hitch with cast swivel eye and heavy duty jack-stand. Optional air suspension axle and/or adjustable track axle, 2.1 – 3 metres.

Wheels & tyres

18.4 x 38" on 4000 & 5000 litre models;
20.8 x 42" on 6000 litre models;
Mudguards optional (all models).
Mudflaps optional (all models).

Pump

AR positive displacement oil-bath four diaphragm pump, chemical resistant, rated to 20 bar. Normal operating range 1 – 8 bar. Standard 185 l/min output (at zero pressure), optional 250 & 280 l/min pumps available. PTO drive standard, hydraulic optional.

Filtration

Five filtration points: Basket (18 mesh), Filling filter (32 mesh), Suction filter (50 mesh), Pressure filter (100 mesh), Nozzle filters (50 or 100 mesh).

Controller & boom valves

MT3405 Microtrak fully automatic controller fitted. Three electric (motorized) boom section valves are fitted as standard (4, 5 or 7 optional), dump & servo fitted, Polmac rapid-check flowmeter with in-cab console with switches, showing spray rate and other functions. Optional BA7000 or ZYNX X20 system for dual line operation.

Boom & Lift

24, 28, 30, 33 & 36 metre booms are options (model dependent). The boom is constructed of high quality steel in a lattice design. Finish is in epoxy-coat paint for chemical resistance. Outer boom wings are fitted with self-returning breakaways. The centre boom section acts as a self-leveler, with adjustment for anti-yaw. Boom liquid tubing is stainless steel, with single non-drip nozzles fitted as standard. Dual lines or triplex nozzle bodies are optional. Boom folds hydraulically, and a wing-lift version is offered on all models. The parallelogram height adjuster has a 2000mm lift (2.5 metre from ground), and is equipped with hydraulic accumulator for boom suspension. Automatic hydraulic boom levelling available with ZYNX X20 system controller

Agitation

Dual supra-flow agitators are fitted. Pump bypass also aids agitation & mixing.

Foam Marker (if fitted)

An air-compressor runs off the pump, and feeds the air-tank, which in turn operates the optional high-capacity Outback Foam Marker, which has in-cab controls. A 130 litre foam concentrate tank is fitted.

Chemical handling

Integrated chemical mixer/induction unit is fitted with a drop-leg device. Options include a chemical suction probe, enviro-transfer kit and a Dosmatic injection kit. A 30 litre hand-wash tank is also fitted for safety.

Flushing & controls

A 340 litre flushing tank is fitted, operated from the easy-to use control panel, located on the left hand side of the sprayer.

Options

Hydraulic pump drive, 250 or 280 l/min pump upgrade, 4/5/7 boom sections, dual lines, axle width adjustment kit, air-ride axle kit, mudguards and mudflaps, BA7000 controller, Induction probe, enviro-transfer kit, filling flowmeter, foam marker and/or GPS Guidance system, left & right wing-lift, independent outer wing fold kit, manual or electric fence-line nozzles, larger wheels and tyres.

Machine specifications are subject to change without prior notification.

Your Sprayer's Specifications

Important Information

IMPORTANT! Tick the fitted options for your sprayer on this page for future reference.

Pegasus Options:

	<i>Tick Your Sprayer's Options (✓)</i>	<i>Tick Your Sprayer's Options (✓)</i>	<i>Tick Your Sprayer's Options (✓)</i>
Tank:			
• 4000	<input type="checkbox"/>	Adjustable tracking kit, 2-3 metre	<input type="checkbox"/>
• 5000	<input type="checkbox"/>	Triplex Nozzles	<input type="checkbox"/>
• 6000	<input type="checkbox"/>	Dual spray lines	<input type="checkbox"/>
Wheels & tyres:		Mudguards	<input type="checkbox"/>
• 18.4 x 38	<input type="checkbox"/>	Mud Flaps	<input type="checkbox"/>
• 20.8 x 42	<input type="checkbox"/>	Filling flowmeter	<input type="checkbox"/>
• 14.9 x 46	<input type="checkbox"/>	Chemical suction probe	<input type="checkbox"/>
Boom size:		Filling pump:	
• 24m	<input type="checkbox"/>	• Motorised	<input type="checkbox"/>
• 28m	<input type="checkbox"/>	• Hydraulic drive	<input type="checkbox"/>
• 30m	<input type="checkbox"/>	Controller:	
• 33m	<input type="checkbox"/>	• MT3405	<input type="checkbox"/>
• 36m	<input type="checkbox"/>	• BA7000	<input type="checkbox"/>
Boom sections:		• ZYNX	<input type="checkbox"/>
• 3-section	<input type="checkbox"/>	Foam Marker or Guidance:	
• 4-section	<input type="checkbox"/>	• ZYNX GPS Guidance	<input type="checkbox"/>
• 5-section	<input type="checkbox"/>	• Outback RA Foam marker	<input type="checkbox"/>
• 6-section	<input type="checkbox"/>	• OutbackS GPS Guidance	<input type="checkbox"/>
• 7-section	<input type="checkbox"/>	• Outback Mapping	<input type="checkbox"/>
Left/right short-fold kit	<input type="checkbox"/>	• Outback 10 Foam Marker	<input type="checkbox"/>
Left/right wing-lift kit	<input type="checkbox"/>		
Auto boom levelling	<input type="checkbox"/>		
Air axle suspension system	<input type="checkbox"/>		
		Fence-line nozzle:	
		• Manual	<input type="checkbox"/>
		• Electric	<input type="checkbox"/>
		Pump:	
		• AR185	<input type="checkbox"/>
		• AR250	<input type="checkbox"/>
		• AR280	<input type="checkbox"/>
		Pump Drive:	
		• PTO	<input type="checkbox"/>
		• Hydraulic	<input type="checkbox"/>
		Enviro-transfer kit	<input type="checkbox"/>
		Dosmatic kit	<input type="checkbox"/>
		Axle & Stub Axles	
		(refer to "Axles & Stub Axles", Section 7 of this manual).	

Your Product Code:
Your Serial Number:

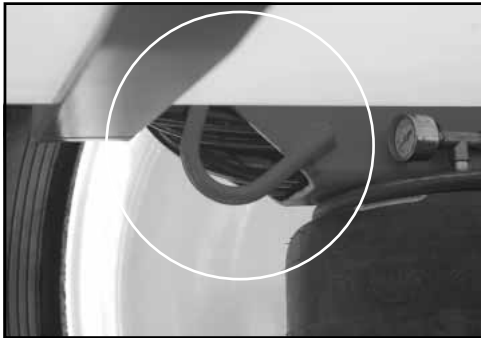

Use the tie-down points provided when transporting.



6000 litre Pegasus with 20.8 x 42 single wheels.

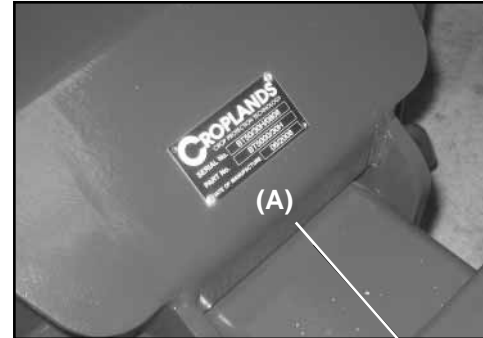

Pegasus Serial Number

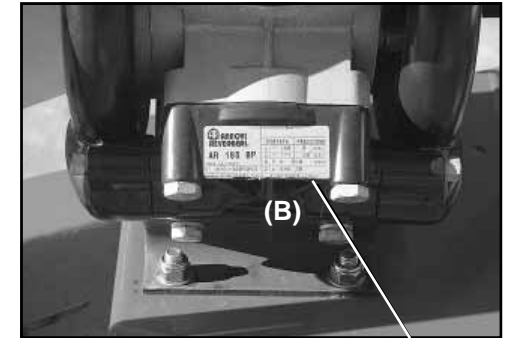

AR Pump Serial Number

Shipping Information

The following shipping information is provided but variations can occur without prior notification.

Approx Weight

Model	Approx Dry Weight
4000 litre	3900 kg (24m boom)
5000 litre	4300 kg (30m boom)
6000 litre	5000 kg (36m boom)

Maximum Towing Speed

Do not exceed 30 kph when towing on roads.

Dimensions (Approx)

Model	W x L x H (boom folded)
4000 litre	2.6m x 7.9m x 3.3m (24m boom)
5000 litre	2.6m x 7.7m x 3.65m (30m boom)
6000 litre	3.5m x 7.7m x 3.8m (30m boom) (with boom folded)

Product Identification

Always use the serial number of the Pegasus when requesting service information or when ordering parts.

Early or later models (identification made by serial number) may use different parts, or it may be necessary to use a different procedure for specific service operations.

Pegasus Serial Number Plate

The Pegasus Serial Number Plate is located on the chassis above the hitch adjustment (A).

This plate shows name of manufacturer, serial number, product code and date of manufacture.

Pump Serial Number Plate

The Pump Serial Number Plate is located on the pump (B).

This plate shows name of manufacturer, serial number, type of pump, year of manufacture, maximum flow rate and maximum working pressure of the pump.

Foam Marker Serial Number Plate

The serial number provides important information about your Outback RA Marker and may be required to obtain the correct replacement part(s).

The serial number plate for the marker is located on the bottom right side of the enclosure. It is suggested that the serial number be recorded.

Foam Marker Serial Number



Warranty Policy

Croplands Equipment Pty Ltd (trading as Croplands) warrants to its authorised Dealer, who in turn, warrants to the original purchaser (Owner) that each new Croplands' sprayer, part or accessory will be free from proven defects in material and workmanship for twelve (12) months from the date of delivery to the first Owner according to the conditions outlined. This warranty does not cover damages resulting from abuse, accidents, alterations, normal wear or failure to maintain or use the Croplands product with due care.

During the warranty period, the authorised Croplands Dealer shall repair or replace, at Croplands option, without charge for parts and labour any part of the Croplands product, which fails because of defects in material or workmanship. The Owner must provide the authorised Dealer with prompt written notice of the defect (within 14 days of its occurrence), and allow reasonable time for replacement or repair. Repair may, at Croplands option, include the replacement of parts with functionally equivalent reconditioned or new parts. Replacement parts will be warranted for the balance of the original warranty period or for ninety (90) days, whichever is longer. Croplands (at its option) may request failed parts to be returned to the factory. Any travel time of a service technician and/or transportation of the Croplands product to the authorised servicing Dealer for warranty work are the responsibility of the Owner.

EXCLUSIVE EFFECT OF WARRANTY AND LIMITATION OF LIABILITY THIS WARRANTY IS IN LIEU OF ALL WARRANTIES OF MERCHANTABILITY, FITNESS FOR A PURPOSE OR OTHER REPRESENTATIONS, WARRANTIES OR CONDITIONS, EXPRESSED OR IMPLIED. The remedies of the Owner set forth herein are exclusive. CROPLANDS neither assumes nor authorises any person to assume for it any other obligation or liability in connection with the sale of covered machines. Correction of defects, in the manner and for applicable period of time provided above, shall constitute fulfillment of all responsibilities of CROPLANDS to the Owner, and CROPLANDS shall not be liable for negligence under contract or in any manner with respect to such machines. IN NO EVENT SHALL THE OWNER BE ENTITLED TO RECOVER FOR INCIDENTAL, SPECIAL OR CONSEQUENTIAL DAMAGES SUCH AS BUT NOT LIMITED TO, LOSS OF CROPS, LOSS OF PROFITS OR REVENUE, OTHER COMMERCIAL LOSSES, INCONVENIENCE OR COST OF RENTAL OR REPLACEMENT EQUIPMENT.

Conditions of Warranty

1. The warranty is not transferable.
2. The Warranty Registration Form must be returned to Croplands by the Owner Operator within 14 days of taking delivery of the unit. Only when warranty registration is completed and returned, can Croplands fulfill all warranty obligations.
3. **Schedule of components and conditions not covered by warranty are:**

Abuse Failure resulting from neglect, such as improper operation, lack of required maintenance or continued use of a sprayer after the discovery of a defect which results in greater damage to the unit.

Environmental Conditions and Application Deteriorated or failed components such as: diaphragms, O-rings, hoses, seals, electrical wiring and connections damaged by corrosive chemicals, dirt and sand, excessive heat or moisture. Owners should ensure the type and strength of chemicals used in the sprayer are compatible with the design of the unit.

Warranty determination for these types of failures will be made by Croplands only after inspection of failed components. In most instances these will incur inspection charges and cost of replacement parts.

Normal Wear

Normal wear and consumable items such as: oils and lubricants, diaphragms, filter elements, flowmeters, clutches, bearings, fan belts, drive belts, pivot pins, paint, light bulbs and nozzles are considered to be normal wear items and are not warranted.

Maintenance

Component failure caused by not performing scheduled maintenance service such as: oils, grease, failure to clean tanks, pumps, filters, spray lines, nozzles or any other blocked components. Not tightening or replacing loose or missing bolts, nuts, fittings, shields and covers.

Damage

Damages or machine failure caused by carelessness or accidental damage, improper operation, excessive speed during travel and operation, inappropriate transportation or storage of the sprayer or attachment.

Power Source

Failures due to faulty or inadequate electrical sources of power. Owners who use their own 12 volt power source must make sure that it is suitable for operating the spraying equipment.

Alterations

Any unauthorised alteration, modification, attachments or unauthorised repairs to the Croplands sprayer or attachments. Written approval must be obtained from Croplands for any such items to maintain warranty.

Removal & Installation

The time taken to remove and re-install a warranted part or component into other brands of sprayers will not be covered by Croplands warranty. Only parts and labour directly attributable to the repair of the Croplands unit is covered.

Clean-up Time

Croplands do not pay for cleaning the sprayer, parts, accessories or work area before or after the warranty repair. Clean-up time is affected primarily by the application or conditions in which the sprayer is operated and maintained. Since clean-up time can be so variable, cleaning time should be considered a customer expense.

Transportation

Warranty does not cover transportation or insurance costs for sprayers or other equipment needing repair or replacement of warranted components. Nor does it cover any freight or insurance costs in obtaining new parts or returning old parts to Croplands for inspection purposes.

Costs

Warranty does not cover time required to diagnose a warranty problem. Diagnostic time is affected greatly by the training and expertise of the technician employed to do the job. With proper training of service personnel, diagnostic time should be at a minimum.

Diagnostic Time

Croplands expects that Dealers will assign a well trained and proficient technician to handle any warranty repairs. Since Croplands is not in control of either of these responsibilities, we elect not to cover diagnostic time.

Non-Genuine Parts

Use of parts other than Croplands parts for repair of warranted parts will automatically negate any warranty. Warranted components must be replaced with genuine Croplands repair parts.

Unauthorised Repairs

Repairs by an unauthorised agent will automatically forfeit any warranty. An authorised Croplands Dealer must carry out warranty repairs.

The Pre-Delivery Check List **must be completed by the Dealer & signed by both the Dealer and the Owner**, and the white copy returned by the Dealer to Croplands.

<p style="text-align: center;"><i>Tick each box to affirm completion</i> ✓</p> <p>1 Operator's Manuals Supplied:</p> <ul style="list-style-type: none"> • Pegasus Parts & Operators Manual <input type="checkbox"/> <p>2 Trailer</p> <ul style="list-style-type: none"> • Undamaged <input type="checkbox"/> • Hitch height adjusted <input type="checkbox"/> • Hitch Jack lubricated <input type="checkbox"/> • Axle adjustment bolts tight (if applicable) <input type="checkbox"/> • Axle nut adjustment, split pin in place <input type="checkbox"/> • Check mudguards <input type="checkbox"/> • Check paint <input type="checkbox"/> <p>3 Wheel Hubs:</p> <ul style="list-style-type: none"> • Greased <input type="checkbox"/> • Bearings adjusted <input type="checkbox"/> • Split pin and dust caps in place <input type="checkbox"/> • Wheel nuts tight <input type="checkbox"/> • Check tyre pressure <input type="checkbox"/> <p>4 Tank</p> <ul style="list-style-type: none"> • Undamaged <input type="checkbox"/> • Agitators adjusted correctly <input type="checkbox"/> • Check main lid opens and seals shut correctly <input type="checkbox"/> • Basket strainer in place <input type="checkbox"/> <p>5 Check All Tank Fittings Are Sealed</p> <ul style="list-style-type: none"> • Agitators <input type="checkbox"/> • Sump outlets <input type="checkbox"/> • Tank rinse nozzle <input type="checkbox"/> <p>6 Boom & Lift Device</p> <ul style="list-style-type: none"> • Undamaged <input type="checkbox"/> • Check hydraulic height adjustment <input type="checkbox"/> • Check boom mounting bolts tight <input type="checkbox"/> • Unfold the boom, and <ul style="list-style-type: none"> • Align wing sections <input type="checkbox"/> • Align wing extensions <input type="checkbox"/> • Align balancing device <input type="checkbox"/> • Adjust sliding surfaces <input type="checkbox"/> • Grease the lift <input type="checkbox"/> • Check gas accumulators <input type="checkbox"/> • Check nozzle spacings <input type="checkbox"/> • Check nozzle mountings tight <input type="checkbox"/> • Check all pins in place <input type="checkbox"/> 	<p style="text-align: center;"><i>Tick each box to affirm completion</i> ✓</p> <ul style="list-style-type: none"> • Lubricate boom hinge points <input type="checkbox"/> • Fold boom to transport position, and <ul style="list-style-type: none"> • Check transport cradles <input type="checkbox"/> • Check that hoses are not kinked or jammed on folding <input type="checkbox"/> <p>7 Power Drive</p> <p>(a) PTO</p> <ul style="list-style-type: none"> • Check quick release pins operate easily and lock into place <input type="checkbox"/> • Check universal joints work correctly <input type="checkbox"/> • Adjust PTO length to suit tractor <input type="checkbox"/> • Grease telescopic sliding shaft <input type="checkbox"/> • Grease universal joints <input type="checkbox"/> • Ensure safety shields are in place <input type="checkbox"/> • Ensure safety chains are securely fitted .. <input type="checkbox"/> <p>(b) Hydraulic Pump Drive & Filling Pump (if fitted)</p> <ul style="list-style-type: none"> • Check pressure & return lines are identified for Hydraulic pump drive <input type="checkbox"/> • Check revs set correctly for hydraulic pump drive <input type="checkbox"/> • Check liquid pump operates correctly <input type="checkbox"/> • Check filling pump operation & control tap <input type="checkbox"/> <p>8 Pump</p> <ul style="list-style-type: none"> • Check mountings <input type="checkbox"/> • Check oil level <input type="checkbox"/> • Check air chamber pressure - 70-100kPa (10-15 psi) <input type="checkbox"/> • Check operation <input type="checkbox"/> <p>9 Suction Lines</p> <ul style="list-style-type: none"> • Undamaged <input type="checkbox"/> • Hoses - no kinks or restrictions <input type="checkbox"/> • All joints sealed (no air leaks) <input type="checkbox"/> • Filter clean & sealed <input type="checkbox"/> <p>10 Pressure Lines</p> <ul style="list-style-type: none"> • Undamaged <input type="checkbox"/> • Hoses - no kinks or restrictions <input type="checkbox"/> • All hoses sealed (no leakages) <input type="checkbox"/> • Filter clean & sealed <input type="checkbox"/> 	<p style="text-align: center;"><i>Tick each box to affirm completion</i> ✓</p> <p>11 Nozzles</p> <ul style="list-style-type: none"> • Undamaged <input type="checkbox"/> • Nozzle filters clean <input type="checkbox"/> • Nozzles correct type throughout <input type="checkbox"/> • Nozzle caps sealed (no leakages) <input type="checkbox"/> • Non-drip diaphragms working <input type="checkbox"/> • Check fenceline sprayer operation <input type="checkbox"/> <p>12 Agitation</p> <ul style="list-style-type: none"> • Check both agitators work <input type="checkbox"/> • Check hoses are properly sealed <input type="checkbox"/> <p>13 Bottom-Fill (Spray/Flush Tanks)</p> <ul style="list-style-type: none"> • Check bottom-fill operates <input type="checkbox"/> • Filter clean & sealed <input type="checkbox"/> • Check hoses properly sealed <input type="checkbox"/> • Check caps & plugs in place <input type="checkbox"/> <p>14 Chem-E-Flush</p> <ul style="list-style-type: none"> • Check unit is undamaged <input type="checkbox"/> • Check hoses/fittings seal correctly <input type="checkbox"/> • Check Chem-E-Flush operation <input type="checkbox"/> <p>15 Chemical Probe (if ordered)</p> <ul style="list-style-type: none"> • Undamaged <input type="checkbox"/> • Check fittings seal correctly <input type="checkbox"/> • Check probe operation <input type="checkbox"/> • Check caps & plugs in place <input type="checkbox"/> <p>16 Automatic Controller</p> <ul style="list-style-type: none"> • Check installation <input type="checkbox"/> • Check battery connection <input type="checkbox"/> • Calibrate controller <input type="checkbox"/> • Fully check controller operation <input type="checkbox"/> <p>17 Fresh Water & Flushing Tanks</p> <ul style="list-style-type: none"> • Undamaged <input type="checkbox"/> • Check fittings <input type="checkbox"/> • Check operation <input type="checkbox"/> <p>18 Main Control & Drain Valves</p> <ul style="list-style-type: none"> • Check there are no leaks <input type="checkbox"/> • Check all valves open & close easily <input type="checkbox"/> <p>19 Foam Marker</p> <ul style="list-style-type: none"> • Check foam tank mountings <input type="checkbox"/> • Check battery connection <input type="checkbox"/> • Hoses - no kinks or restrictions <input type="checkbox"/> 	<p style="text-align: center;"><i>Tick each box to affirm completion</i> ✓</p> <ul style="list-style-type: none"> • All joints sealed (no air leaks) <input type="checkbox"/> • Check filters are clean <input type="checkbox"/> • Check foam marker & in-cab control operation <input type="checkbox"/> <p>20 Air-Ride Axle</p> <ul style="list-style-type: none"> • Check air reservoir pressure <input type="checkbox"/> • Set air suspension ride height <input type="checkbox"/> <p>21 GPS Guidance</p> <ul style="list-style-type: none"> • Check operation <input type="checkbox"/> <p>22 Enviro-Transfer Kit</p> <ul style="list-style-type: none"> • Check operation <input type="checkbox"/> <p>23 Decals</p> <ul style="list-style-type: none"> • Check all decals are in place <input type="checkbox"/> <p>OWNER: Farmer <input type="checkbox"/> Contractor <input type="checkbox"/></p> <p>Owner's Name: (Print)</p> <p>Address:</p> <p>..... Postcode:</p> <p>Phone:</p> <p>Mobile:</p> <p>Email:</p> <p>Signature of Owner</p> <p>.....</p> <p>Date:</p> <p>DEALER:</p> <p>Dealership Name: (Print)</p> <p>.....</p> <p>Address:</p> <p>.....</p> <p>..... Postcode:</p> <p>Signature of Dealer Representative</p> <p>.....</p> <p>Date:</p>
---	---	--	--

Warranty Registration: The Owner acknowledges that the Owner has read & understood all terms & conditions of the Croplands' warranty policy contained in this manual. The warranty policy will commence upon installation. This Warranty Registration **must be completed & signed by both the Owner & the Dealer**, & the white copy returned by the Dealer to Croplands.

Implement Type:
Model:
Size:
Product Code:
Serial No:
Purchase Date:
Pre-Delivery Completion Date:

OWNER:
 Owner's Name: (Print)
 Address:
 Postcode:
 Phone: Mobile:
 Email:
 Signature of Owner:
 Date:

DEALER:
 Dealership Name: (Print)
 Address:
 Postcode:
 Phone: Mobile:
 Email:
 Signature of Dealer Representative:
 Date:

IMPORTANT:

By executing this Warranty Registration:

1 The Owner:

- (a) Agrees that the Owner will read the Operator's Manual before using the Sprayer; will follow all procedures in the operator's manual for the use of the Sprayer, and will exercise due care in the use of the Sprayer;
- (b) Agrees that Croplands' liability for any loss or damage suffered by the Owner in connection with the Owner's use of the Sprayer is limited to the cost of repair or replacement of the Sprayer;
- (c) Agrees that the Owner will bear any loss the Owner suffers as a consequence of any failure by the Owner to comply with 1.1 above;
- (d) Acknowledges that the owner is trained and is fully responsible for the safe and correct operation of the Sprayer; and
- (e) Agrees that the Owner will fully train any person who might be required to operate the Sprayer as to how to operate the Sprayer in a safe and proper manner.

2 The Dealer undertakes that the Dealership has met the obligations of Sprayer pre-delivery, installation, service and warranty start up.

Owner's Machinery Register: *(This information will assist us in providing first class back-up and parts service)*

- 1 Type of purchaser (please tick): Owner/Farmer Share Farmer Contractor
- 2 Major activities (please number in order of importance):
 - Sheep Nuts Nurseries Vineyards
 - Beef Vegetables Fruit Trees Council/Govt
 - Cereal Grain Flowers Parks & Lanes Other
 - Cotton Dairy Sugar Cane
- 3 What is the size of your holding (hectares)?
- 4 What are your reasons for purchasing the Croplands Sprayer?

5 What other Croplands' machinery do you currently use?

Serial No.	Implement Type	Size	Age	Comments
.....
.....
.....
.....
.....

Safety	2.2
Hook-up	2.10
Un-hook	2.19
Main Controls & Functions	2.20
Pre-Operation Check	2.21

Safety is the Operator's Responsibility

The Pegasus is designed to meet the most demanding farming conditions, where large areas, uneven terrain, and weather-controlled deadlines set the toughest challenges.

The Pegasus is capable of spraying a wide range of pesticides and fungicides and the operator must be aware of the hazards associated with the Pegasus operation.

The dealer explains the capabilities, application and restrictions of the Pegasus.

The dealer demonstrates the safe operation of the Pegasus according to Croplands instruction material, which are also available to operator.

The dealer can also identify unsafe modifications or use of unapproved attachments.

The following publications provide information on the safe use and maintenance of the Pegasus and attachments:

- The Operator's Manual delivered with the Pegasus gives operating information, as well as routine maintenance and service procedures. It is a part of the Pegasus and must stay with the machine when it is sold.
 - Replacement Operator's Manuals can be ordered from your Croplands dealer, Pegasus Part No. BT-POM 1203.
 - The Pegasus has machine signs (decals) which instruct on the safe operation and care. The signs and their locations are shown in the Operator's Manual.
- Replacement signs are available from your Croplands dealer (as shown on pages 2.4, 2.5, 2.6).

Safe Operation Needs a Qualified Operator

A Qualified Operator Must Do the Following:

1 Understand the Written Instructions, Rules & Regulations

- The written instructions from Croplands are included in the Pegasus Operation & Maintenance Manual and on machine decals.
- Check the rules and regulations at your location. The rules may include any Federal and State safety requirements for the chemical applicator.

2 Have Training with Actual Operation

- Operator training must consist of a demonstration & verbal instruction. This training is given by your dealer before the Pegasus is delivered.
- The new operator must start in an area without bystanders and use all the controls until they can operate the Pegasus safely all conditions of the work area.

3 Know The Work Conditions

- The operator must know any prohibited uses or work areas. They need to know about excessive slopes and rough terrain.
- Wear protective clothing as recommended by the chemical manufacturer. Always wear safety goggles when maintaining or servicing Pegasus.
- For an operator to be qualified, they must not use drugs or alcoholic drinks which impair alertness or coordination while working.

An operator who is taking prescription drugs must get medical advice to determine if they can safely operate a machine.

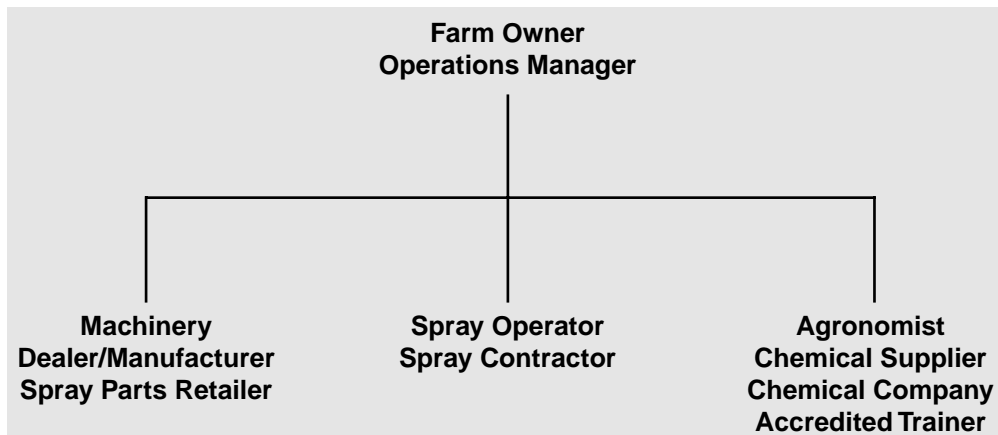

NOTE

There are accredited training programmes for spray application in each state. We recommend all operators have accredited training.

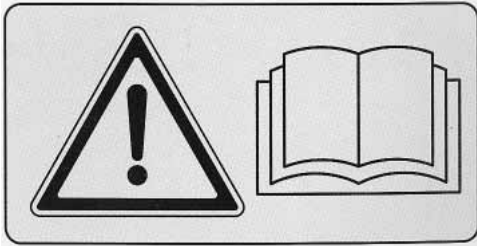

Rules for Safe Pegasus Operation

- Always read your sprayer operator's manual thoroughly before operating. Accidents occur every year because of careless use of farm chemicals and farm machinery. You can avoid these hazards by observing these safety instructions.
- Dispose of all chemical containers as per instructions on label. Failure to do so could result in contaminating the environment with chemicals.
- Inspect hose and hose connections daily. Always wear rubber gloves when tightening connections. Damaged, loose or worn hoses could result in operator being exposed to toxic chemicals which could result in serious illness or faulty sprayer operation.
- Always use the proper application rate. To assure proper application rate calibrate sprayer correctly. The wrong application rate of a pesticide concentration that is too high may expose the operator and the environment to danger.
- Follow the chemical manufacturer's precautions before cleaning the sprayer. Exposure to chemicals could result in serious illness or death.
- Always wear gloves and wash the machine before doing any disassembly repair work. Chemical residues on the machine parts could contaminate operator or service personnel causing serious illness.
- Always relieve system pressure before doing any work on the machine. Failure to do so could cause operator to be exposed to high pressure spray of chemical resulting in serious injury or machine damage.
- Always be sure all guards are properly installed on machine before operating. Failure to do so could result in entanglement in moving parts resulting in serious injury to operator.
- Always keep PTO guard in place when sprayer is operating. Failure to do this might result in entanglement.
- Be sure to disconnect the battery before attempting welding repairs.
- Always wear relatively tight and belted clothing to avoid entanglement in moving parts. Failure to do so could result in serious injury.
- Always stay out from under the sprayer unless it is resting on the ground or supported on solid blocks. Hydraulics or jacks could fail letting the sprayer fall. This could result in pinning or crushing of personnel.
- Check the entire sprayer, prior to each use, for any loose bolts or mechanical connections. These precautions can prevent injury to personnel and damage to equipment.
- Only inflate tyres to rated pressures. Over inflating causes tyres to burst resulting in serious injury.
- Use only genuine Croplands parts for any necessary replacement. Special alloy steels are used in many parts which are important to the equipment design. Home made parts may look the same but might be dangerous in operation.
- Do not ride on machine when in motion. This is an unsafe practice and can lead to serious injury should the rider fall from the machine.
- Always replace warning decals when damaged and make certain operator understands proper safety practices.
- Always stand well clear of sprayer when operating. The sprayer is capable of spraying chemicals 20-30 metres from the boom which may be hazardous to humans.
- Do not disconnect any hoses nozzles or filters while sprayer is operating. Disconnecting components while under pressure will result in uncontrolled spray discharge which may be hazardous to humans.
- Always clean the Pegasus and disconnect the battery before doing any welding repairs. Cover rubber hoses, and all other flammable parts. Keep a fire extinguisher near the Pegasus when welding. Have good ventilation when grinding or welding painted parts. Wear dust mask when grinding painted parts. Toxic dust or gas can be produced.

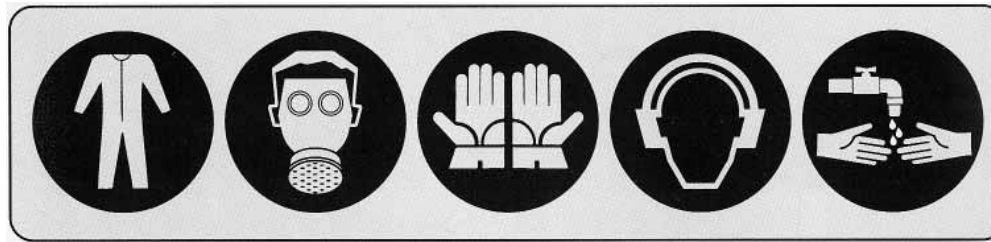
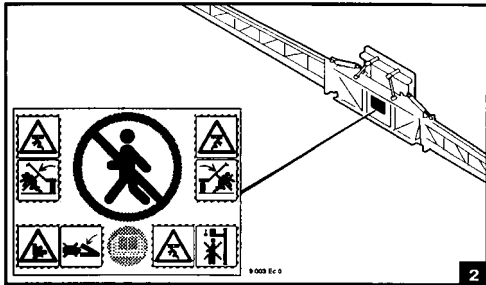

Make sure all boom safety decals are clear and in place. Replace them if damaged



Danger of arms crushing.
This area must be kept clear during equipment operation.



Danger of body crushing.
This area must be kept clear during equipment operation.



Danger of body crushing.
This area must be kept clear during equipment operation. do not stand within range of boom arms



Danger of PTO entanglement.
This is a common injury in farming. Ensure PTO covers are always in place.



Rules for Safe Use of Chemicals

- Always read the label before using chemicals. Follow instructions from chemical manufacturer on how to select, use and handle each chemical. Note protection information each time before opening the container.
- Always observe all warnings on chemical products. Failure to do so could result in operator or others being exposed to toxic chemicals which could result in serious illness. Remember chemical manufacturers go to much research and expense to develop labels for your protection.
- Be sure you recognise the categories of toxicity and their key words.
- Verbal warnings must be given if written warnings cannot be understood by workers.
- Do not spill chemicals on skin or clothing. If chemicals are spilled, remove contaminated clothing immediately and wash skin (and clothing) thoroughly with soap and water.

Wash hands and face with soap and water and change clothing after spraying. Wash clothing each day before reuse.
- The spray tank and system should be emptied of chemical mixture and flushed with clean water before servicing the spray system or spraying components. Clean the Pegasus of all chemical residue before servicing.
- Avoid inhaling chemicals. When directed on the label, wear protective clothing, face shield or goggles.
- Never smoke while spraying or handling chemicals.
- Cover food and water containers when spraying around livestock or pet areas.
- If symptoms of illness occurs during or shortly after spraying, call a physician or go to a hospital immediately.
- Follow label directions and advice to keep residues on edible portions of plants within the limits permitted by law.
- Keep chemicals out of the reach of children, pets and unauthorised personnel. Store them outside of the home, away from food and feed and lock them in a secure area.
- Keep bystanders away from spray drift.
- Always store chemicals in original containers and keep them tightly closed. Never keep them in anything but the original containers.

Read labels for hazards about chemical reaction with certain types of metals.

Decals - Please order replacements if required

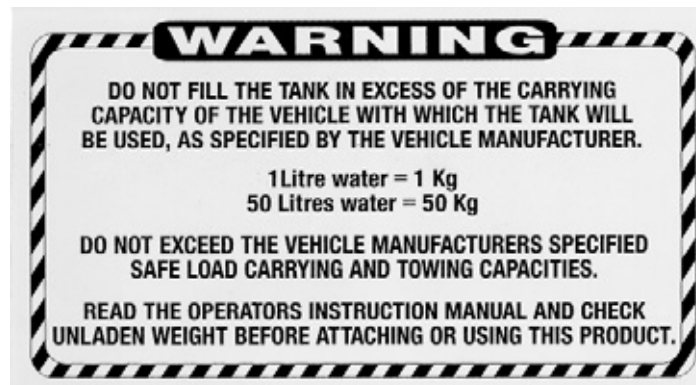
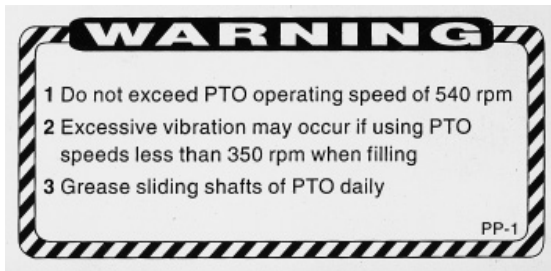
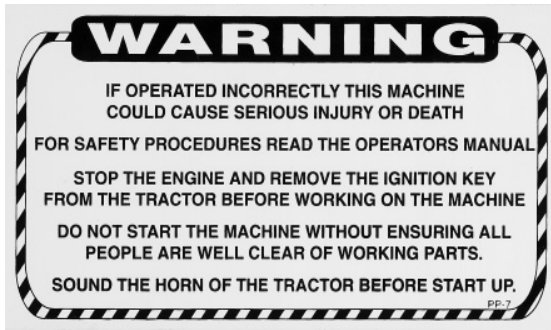

Decals - Please order replacements if required

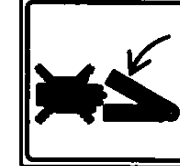
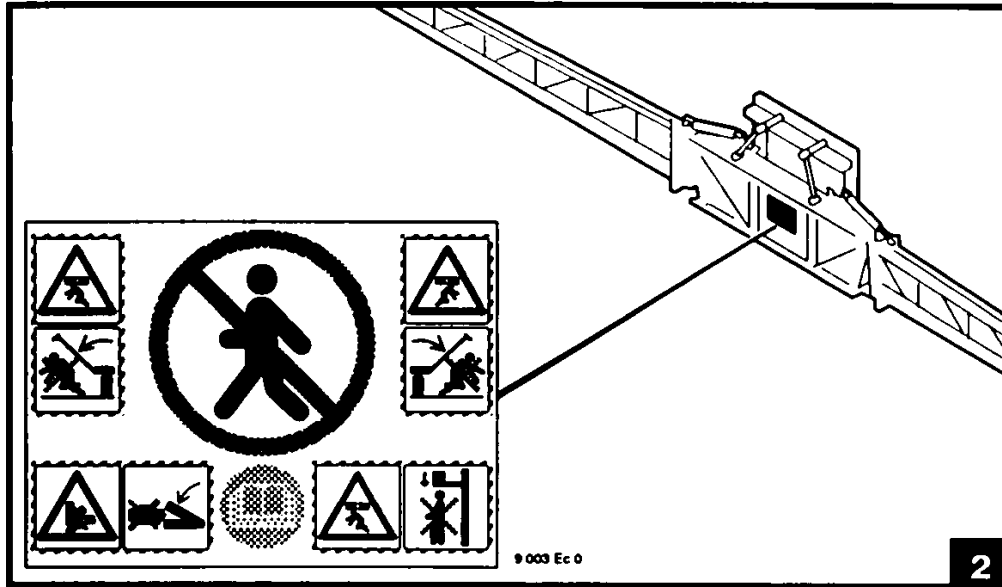

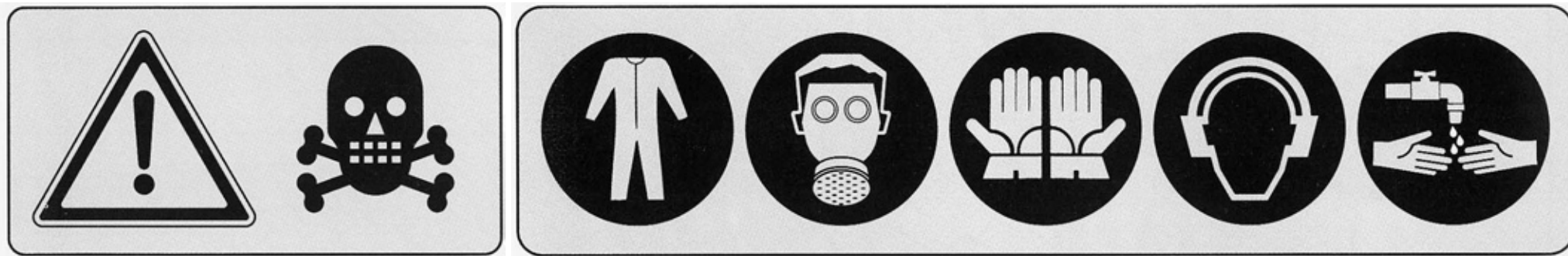

Safety must be an Integral Part of Chemical Farming Operations

- **Not Just an After Thought!**

The Hazard

All agricultural chemicals or pesticides, as they are commonly called, are biologically active. When handled incorrectly or carelessly, they can be dangerous to all living organisms such as humans, birds, fish, bees, domestic animals and plants.

Method of Pesticide Entry

- ☞ **Oral** - Direct by drinking, splashing into mouth, eating and smoking with contaminated hands, eating sprayed produce, cleaning nozzles with mouth.
- ☞ **Inhalation** - Nose, mouth, but predominately the lungs.
- ☞ **Dermal** - Absorption through the skin. Increased when skin is broken or perspiring.

Rate of Absorption

While pesticides are absorbed more completely orally and by inhalation, greater exposure and more poisonings occur through skin (dermal) contact.

Hazard and Chance of Poisoning

The hazard and chance of poisoning is much higher when handling pesticides in concentrate form than in the dilute form.

Safe Handling

Know your Pesticides:

- ☞ **STOP!!** Read the label
- ☞ Is it the right pesticide?
- ☞ What is its poisons schedule or toxicity?
- ☞ What safety precautions are required?
- ☞ What is its persistence and withholding period?
- ☞ What is its mode of action?
- ☞ Will it be a hazard to neighbouring crops and people?

- ☞ What protective clothing and equipment is needed?
- ☞ Know the correct first aid/safety in case of poisoning.
- ☞ Seek medical advice if health is affected by chemicals.

Mixing the Product

- ☞ Reduce or eliminate operator contact by using closed loading systems, auto fillers, wettable powder mixtures or wettable dispersable granules.
- ☞ Use the right protective clothing when handling the concentrate. The user is at greatest risk when handling chemical in concentrate form.
- ☞ Open bags carefully. Cut to open, do not tear.
- ☞ Do not stir chemicals with hands or arms.
- ☞ Choose the mixing site carefully & the fate of the probable residues.
- ☞ Do not mix more spray solution than is needed and avoid needless disposal of unwanted chemicals.

Plan your Spray Route

- ☞ Observe weather conditions, especially wind direction & speed.
- ☞ Try to travel across wind and into untreated crop.
- ☞ Prevent double or over spraying.
- ☞ Prevent or minimise drift onto other crops, workers, etc.

Disposal of Unwanted Pesticides and Containers

- ☞ Calibrate correctly to ensure you do not have a large quantity of unwanted spray left over.
- ☞ Rinse empty containers and pour residue into the spray tank.
- ☞ Dispose of containers in the correct manner and where provided, use pesticide drum disposal schemes.

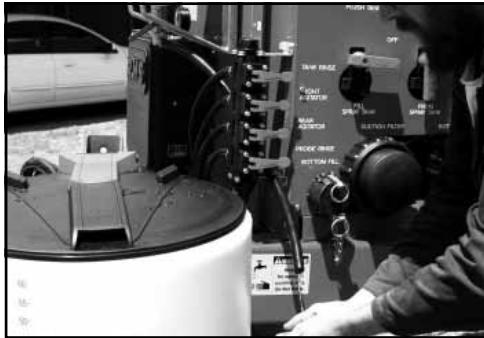

Fresh water on the sprayer for personal safety.



1, 3, 5 litre measuring jugs & 25 litre mixing bucket.



Kasco helmet, Breathable spray suit & gloves.

Croplands Breathable Spray Suits are especially designed and ideally suited to our climatic conditions. They provide greater protection than ordinary fabric and disposable overalls.



Respirator, Breathable spray suit & gloves.

Decontamination

- ☞ Change out of protective clothing and shower as soon as possible after spraying.
- ☞ Wash before eating, drinking or smoking.
- ☞ Provide clean water at filling site and on sprayer in case of field contamination.
- ☞ Wash and clean respirators regularly.

Keep Sprayers and Safety Equipment in Good Working Condition

- ☞ Replace hoses and fittings when they leak.
- ☞ Clean sprayer regularly.
- ☞ Replace respirator filters regularly.
- ☞ Do not use worn, faulty or contaminated safety equipment.

Storage

- ☞ Store pesticides in a locked, well ventilated store.
- ☞ Do not pour pesticides into other containers, especially not drink containers.

Pesticide Free Tractor Cabs

- ☞ Ensure the cab filter is adequate for the pesticide used.
- ☞ Be careful not to contaminate the cabin environment.
- ☞ Cabin filters alone are not adequate when the operator is required to leave the cab to refill the sprayer. Safety equipment used outside the cab should not be stored in the cab.

Protective Safety Equipment

The amount and type of protective clothing and equipment is determined by the type of chemicals, degree and duration of exposure, weather conditions and application equipment used.

Read and follow the direction on the label.

Over protection can be uncomfortable and unnecessary.

A respirator left hanging around your neck is useless.

Measuring

- ☞ Croplands' calibrated, easypour 1, 3 and 5 litre measuring jugs and 25 litre chemical mixing bucket are practical, easy to clean, U.V. resistant and chemical resistant.

Clothing

- ☞ Cover as much of the body as possible, especially the neck, chest and forearms. Use washable fabric overalls, disposable overalls or preferably waterproof clothing especially when coming in contact with large quantities of pesticides. Wear the trouser legs outside the boots.

Gloves and Boots

- ☞ Never use leather or cloth materials because they absorb pesticides and provide a constant source of contamination. Gloves should be un-lined for this reason.

Croplands Nitrile Chemical Handling Gloves are recommended.



Safety goggles for eye protection.



Respirator.



Sample of Agrichemical Manual.

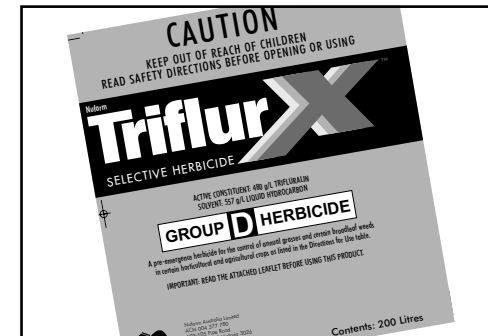

Read the Chemical Label

Head & Face

- ☞ Hard hats, washable hats, goggles, spray helmets and face shields are important when handling concentrates.

Croplands Spray Goggles feature sealed, anti-fog, double lens goggles for practical, comfortable eye protection. Croplands Kasco Spray Hood is fully approved by D.I.R.

Respirators

- ☞ Choose the correct type and have the correct cartridge fitted. Replace cartridges regularly and write the date on each cartridge. Ensure there is an adequate fit to the face.

Croplands' respirators are recommended for most spraying applications.

Operator Safety

When handling pesticides, always use elbow-length gloves, long clothes and above all, a respirator.

If you and your clothing become contaminated with spray, **DO NOT WORK ON.**

Stop work, remove clothing and wash affected areas thoroughly with soap and water. Put fresh clothing on before starting again.

Ensure that contaminated clothing is washed thoroughly before being used again.

Don't guess when choosing protective equipment. Feel free to call Croplands and make use of our safety database for comprehensive information on safety, handling and storage exposure levels, symptoms, health effects, first aid and personal protection.

Spraying Precautions

Agricultural chemicals applied under unfavourable weather conditions or from poorly adjusted and operated equipment can cause damage due to run-off and/or drift problems.

Crops and pastures are more susceptible to spray drift of herbicides while people, stock and water supplies are generally more susceptible to insecticide drift.

Pollution, crop damage and the potential health hazards are something agriculture can ill afford. It is simply not acceptable, socially or environmentally.

Additionally, pesticide which drifts or runs off the target reduces the efficiency of the pesticide on the target. Spray failures are a waste of money and effort.

NOTE

A full agri-chemical manual is available in Australia and New Zealand. Talk to your local Agronomist for more information.

- ☞ **Be SURE** the equipment is functioning correctly. Check that nozzles are in good condition. Check all other aspects of machine operation are correct.
- ☞ **Be SURE** pesticides are mixed thoroughly and according to the label.
- ☞ **Be SURE** the recommended registered pesticide is used for the job at hand.
- ☞ **Be SURE** pesticides are applied at recommended rates.
- ☞ **Be SURE** only target plants are sprayed.
- ☞ **Be SURE** to follow the safety precautions on the label.



The Pegasus is fully assembled at the factory.

Assembly Instructions

The Pegasus is fully assembled when shipped from the factory except for the PTO shaft (as the standard option).

The air-axle suspension, if fitted, should be inflated before setting up the hitch height - see instructions on page 2.18.

If your particular machine has a hydraulic-drive for the pump instead of a PTO shaft, please read the set-up procedure instructions for the hydraulic drive carefully (see page 2.14).

Connect the Pegasus to the Tractor

Seven steps are initially required to hook up the Pegasus to your tractor.

1. Connect the Pegasus hitch to the drawbar and connect safety chains. (see following procedure.)
2. Fit the PTO shaft, if this is supplied (see pages 2.11, 2.12).
3. Connect hydraulic hoses for the boom/height adjuster, and for the hydraulic-drive for your pump if this option is fitted (see pages 2.13, 2.14).
4. Fit the Spray-rate controller (see page 2.16).
5. Fit the Foam marker controller (see page 2.17).
6. Connect all power leads direct to the battery (see page 2.18).
7. Activate the air-bag suspension (if fitted) & check pressure (see page 2.18).



Adjust the hitch jack until the work platform is level.

1 Connect the Pegasus Hitch to the Tractor

To connect the Pegasus hitch to a suitable tractor:

- 1 Check the Pegasus is level fore and aft. The working platform of the sprayer should be level.
If not, adjust the hitch up or down using the hitch jack until the work platform is level.
- 2 Align the Pegasus hitch with the tractor drawbar.

If the Pegasus hitch is higher or lower than the tractor drawbar, adjust the height of the Pegasus hitch to match the tractor drawbar height.



Remove the pin adjust the hitch height as required.

To adjust the hitch height:

- a) Using the front and/or rear pins that hold the adjustable hitch in place, adjust the hitch to the correct angle and height to match your tractor drawbar (see above).
- b) Ensure the pins are correctly re-installed after adjustment is complete (see below).

Ensure the pins are correctly reinstalled.





Unpin and lift up the lift jack base.

- 3 Insert the drawbar pin & lock the retaining pin in position to ensure the pin cannot come out while transporting or operating.
- 4 Connect the safety chains to the tractor chassis or drawbar.
- 5 Fold up the hitch jack:
 - a) Wind up the jack with the handle,
 - b) Push the release button and lift the foot-plate right up to the bottom of the chassis for full clearance.

When in position, release the button to lock it into position

Pin the lift jack into position.



Pegasus BT-POM 1212 - Rev 3



Correctly fit the PTO shaft to the Pegasus.

2 Fit the PTO Shaft

This section is not applicable to any Pegasus fitted with a hydraulic pump drive option (If fitted, go to step 3, page 2.15).

The standard fitted PTO shaft has been fully tested at the factory and packed for transit.

To fit PTO shaft:

- 1 Remove the PTO shaft which is strapped to the Pegasus platform.
- 2 Check the PTO shaft has not been damaged in transit.

- 3 **Measure and fit the PTO** to the Pegasus ensuring the locking pin is correctly located.

Be sure to read, understand and follow instructions on page 2.12, "The important factors for fitting the PTO shaft".

- 4 Grease the universal joints and telescoping shafts.
- 5 Fit the PTO to the Pegasus ensuring the locking pin is correctly located.
- 6 Before operating the drive shaft, be sure that all safety guards and chains are securely in place.

CAUTION

Incorrect fitting of PTO shaft will result in excessive pump vibration, and will likely damage the PTO and pump prematurely.

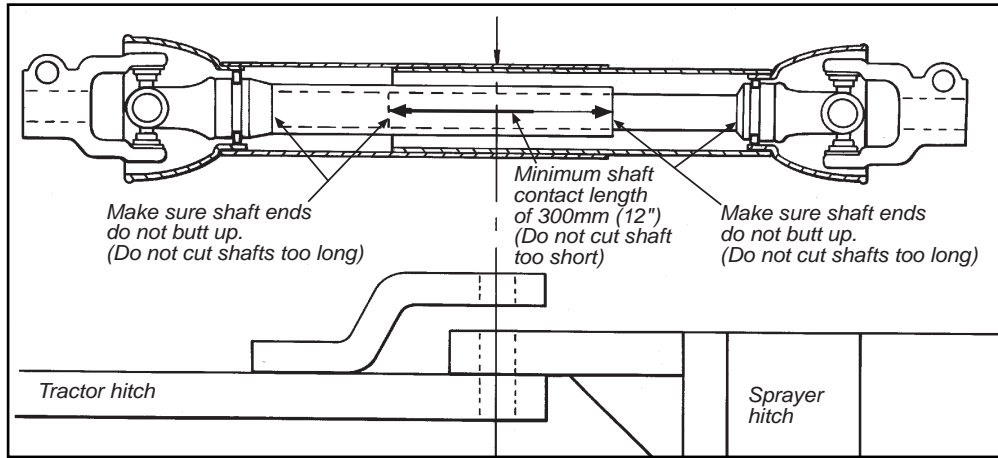

On Standard PTO shafts, it is recommended that the drawbar pin connecting the tractor & Pegasus should be as close as possible, between the two universal joints of the PTO shaft.

Important Factors when Fitting the PTO Shaft

The following three factors must be correct to avoid pump damage and maximise PTO operating life:

- 1 When travelling straight ahead, the point at which the sprayer drawbar pin is joined to the tractor should be as close to centre as possible, between the universal joints of a Standard PTO shaft, as illustrated.

The tractor is then able to make maximum turns with minimal bending of the universals.

- 2 When the tractor is towing the sprayer straight ahead, the two telescopic sections of the power take-off shaft are at maximum extension.

When turning or crossing an inversion, the telescopic shaft sections close up.

- 3 The height difference between the tractor PTO spline and the PTO spline of Pegasus should not be more than 100mm.

This ensures PTO joint angles are approx equal and do not exceed limits. If greater than 100mm, a wide angle (constant velocity) PTO should be used. See Hitch height adjustment instructions on page ?.

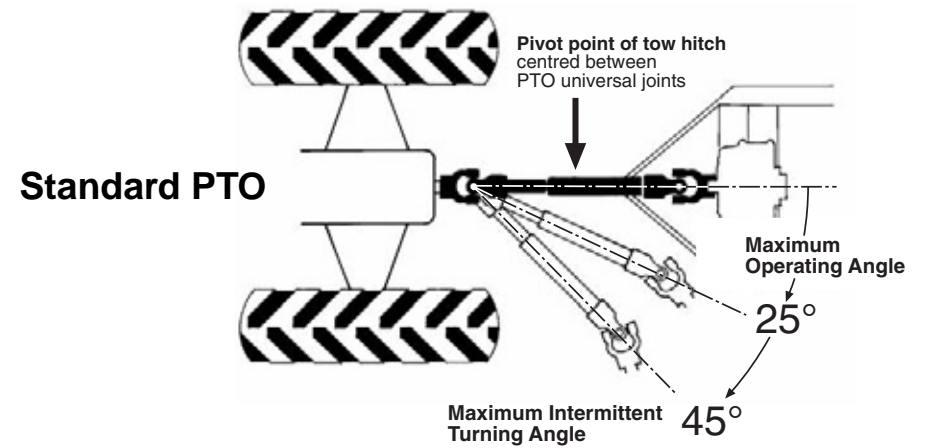

Standard PTO Operating Limits

Heed the Operating Limits of the Standard PTO Shaft

The standard Pegasus is fitted with a STANDARD PTO shaft.

The maximum intermittent turning angles of the Standard PTO shaft is only recommended where should not exceed 45° turning angle of the PTO.

Standard PTO Operating Limits

Maximum spline height difference 100mm (approx) for Standard PTO shafts

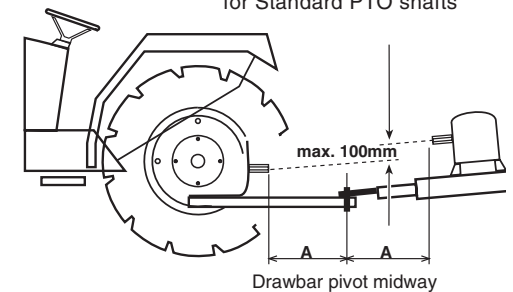

Pegasus BT-POM 1212 - Rev 3

NOTE

IMPORTANT: Do not allow more than 10% difference in the two halves of drawbar length. If more than 10% difference occurs, a wide angle shaft must be used.

CAUTION

Ensure that the drive shaft is the correct length to avoid any "butt up" damage to the pump.

CAUTION

Pump warranty is not valid for damage caused by incorrect PTO shaft mounting.

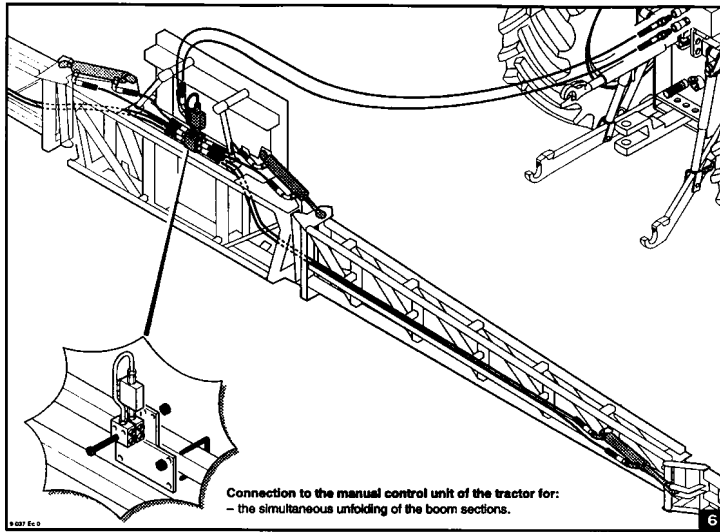

Connection to the manual control unit of the tractor for:
- the simultaneous unfolding of the boom sections.

Boom fold hose connection.

3 Connect Hydraulic Hoses to the Tractor

The standard Pegasus Compact Boom provides simultaneous unfolding of boom sections and hydraulic lift adjustment of boom height.

Prior to connecting your boom hydraulic hoses, remove the boom lock-plate (see pic). This plate is in place for transport to your dealer from the Croplands' factory.

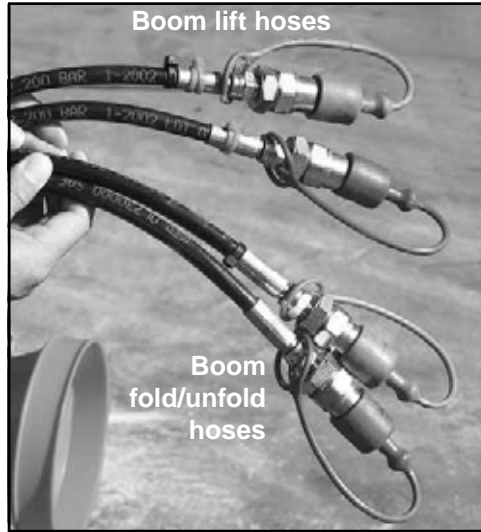

Boom lift hoses

Boom fold/unfold hoses

Standard hose connectors for boom lift and fold.

Connect the boom hydraulic hoses to the tractor, namely:

- a) Boom fold hoses.
- b) Boom parallelogram lift hoses.
- c) If fitted, connect the hoses for the wing lift (optional) - see following pages.
- d) If fitted, connect the hoses for the hydraulic pump drive (optional) - see following pages.

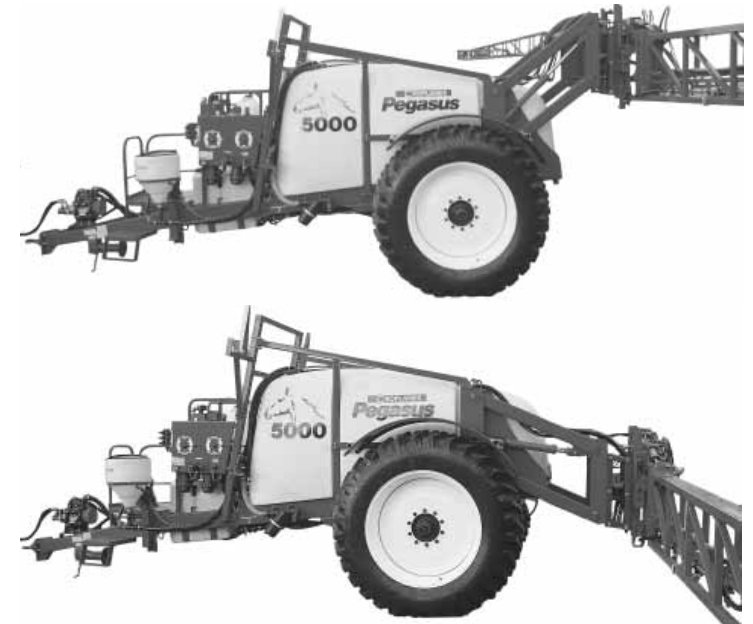

Boom lift shown in raised and lowered position.

Prior to operating remove the boom lock-plate (in position).

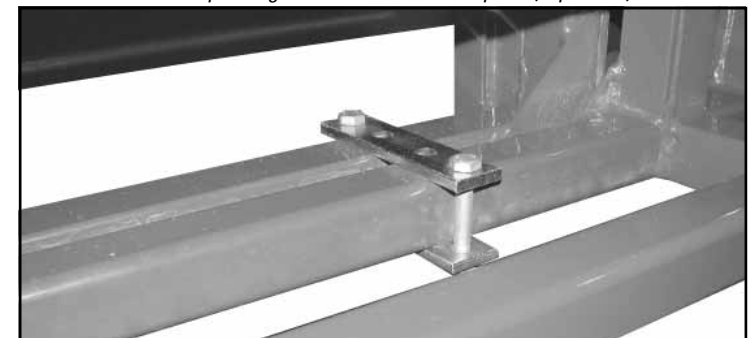

! WARNING

Prior to operating the boom hydraulics, remove the boom lock-plate as shown on right.



Electric/hydraulic valves.



Connect electric/hydraulic console cables at rear of tractor.

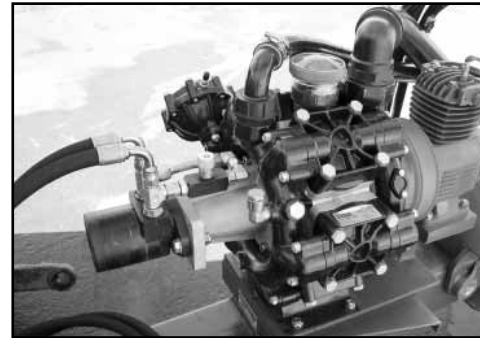

Hydraulic drive pump.

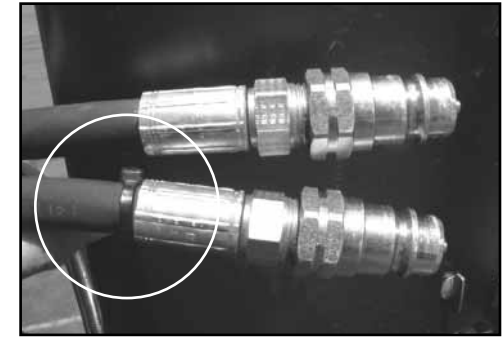

Hose marked with cable-tie is for the PRESSURE line.

3a Electric/Hydraulic Valves

If your sprayer is fitted with wing-lift, and/or independent outer wing fold, the hydraulic system on the sprayer consists of electric over hydraulic valves to enable all functions to be operated from one set of hydraulic remotes.

- 1 Hook up the hydraulic hoses to the tractor remotes.
- 2 Install the electric/hydraulic control console in the cab in a suitable location.

- 3 Ensure the power leads are connected to the battery terminals (See page 2.18 "auxiliary power leads").
- 4 Connect black trailer plugs at rear of tractor (see pictures above & below).

Once the boom & lift hydraulic system is hooked up correctly, test the boom functions with the tractor running. Ensure your working/testing area is clear of bystanders.

If your sprayer is fitted with a hydraulic pump drive, connect the hydraulic hoses to the tractor remotes.

3b Hydraulic Pump Drive Set-up

Open Centre System

- 1 If your pump is fitted with a hydraulic pump-drive, connect the hydraulic pressure and return lines to your tractor remote.

Electric/hydraulic control console.



NOTE

Please read the following page to ensure you know if your tractor has open or closed centre hydraulics.

This is **VERY IMPORTANT** to ensure your pump drive works correctly.

NOTE

Ensure the marked hydraulic line is designated as your pressure line (see pic above)



Speed adjustment flow-control valve.

- 2 Open the speed adjustment flow-control valve fully by winding it out anti-clockwise – this must be done prior to engaging your hydraulics
- 3 Engage the hydraulic control in the cab of the tractor
- 4 Close the speed adjustment flow-control valve slowly by turning it clockwise until the desired RPM of the pump is reached. Ensure the RPM DO NOT exceed 540.

Closed Centre System

Leave the control valve closed on the pump and adjust from the tractor to reach the desired speed.
Do not exceed 540 RPM.

NOTE

Consult your Croplands dealer if you require assistance with determining pump RPM.

The dealer will be able to calibrate this using an RPM meter or rev counter.

Open Centre vs Closed Centre Hydraulics

For the best operation of your hydraulic-drive Diaphragm pump or hydraulic-drive filling pump, there are some adjustments that can be made by your dealer on your tractor hydraulics for best performance & lower heat generation to protect your tractor.

In general terms, there are three systems, which are described below:

Open Centre Systems

In an open centre system, the hydraulic pump on the tractor puts out a constant flow. If the pump puts out more oil than the hydraulic-drive motor can use, a portion of the oil must be bypassed around the motor.

When the oil is bypassed around a loop and does no work, the energy put into it by the pump turns into heat. Therefore, the amount of oil bypassed should be kept to a minimum.

Tractor adjustments may be necessary, consult your dealer if you are unsure.

Closed Centre (Pressure Compensated) Systems.

The closed centre pressure-compensated system has a variable displacement pump which will deliver flow at the necessary rate to maintain a specified pressure.

It is best to have the pump operating at around 1800 to 2100 psi with the relatively low-flow hydraulic drive motor fitted to the Pegasus (if fitted).

Tractor adjustments may be necessary, consult your dealer if you are unsure.

Closed Centre Load Sensing Systems (Flow and Pressure Compensating).

The closed centre flow-compensated system is a variation of the pressure-compensated system, designed primarily for more efficient operation and the generation of less heat.

It works on the principle of maintaining a constant pressure drop from the pump to the work port of the selector valve.

Any variation in the demand at the motor will cause a change in flow.

The system senses this change in flow due to the change in pressure drop across the valve, and causes the pump to compensate by varying the pump flow.

No restrictor is required in the pressure line and no oil is bypassed.

Check with your dealer to see if your tractor has this system.



MT3405 Controller standard.

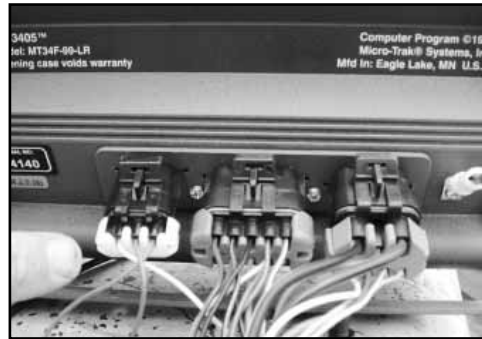

Connect the leads of the Controller to loom.

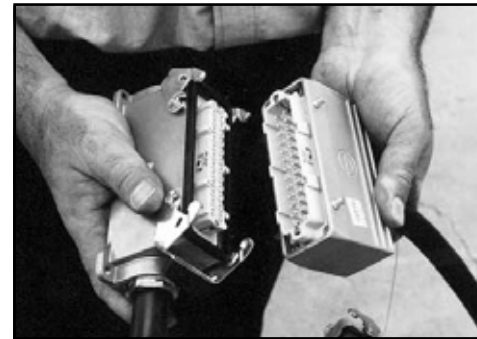

Connect the main loom couplings.



Dual lines on the boom.

4 Fit the Spray Controller

The Spray Controller has been fitted and fully tested at the factory but has been disconnected and packed for transit.

To fit the Spray Controller:

- 1 Unpack the Spray Controller and cables.

- 2 Connect the leads at the rear of the Spray Controller (shown connected).
- 3 Fit the Spray Controller console into the tractor cab in a convenient and safe location for the operator.

- 4 Connect and lock together the main loom couplings at the rear of the tractor.

Dual Line Option

(See page 3.24 for more information)

If you have chosen dual lines to be fitted to your sprayer, you will be familiar with the use of this option on your Pegasus sprayer.

In general terms, there are usually two reasons to have dual lines fitted:

- 1 To increase the boom output using the same speed setting by introducing a second boom line - this negates the need to change nozzles to perform this task, and;
- 2 To increase the speed range available for your sprayer by having the second boom line cut in/out at a given speed.

NOTE

Ensure any colour coded cable-ties on the looms are matched.

If the ZYNX X20 controller is fitted, refer to the X20 Instruction manual for installation guidelines and connection diagrams.

NOTE

The male plug has locating holes so it can be mounted on the rear of the cab. Likewise, if you have an electric/hydraulic control console for a wing-lift boom; it is recommended the black trailer plug also be fixed next to the main loom connector (see page 2.14).

Ensure dust caps are fitted to the Controller cable couplings when disconnected.

Lock the Controller couplings together.

NOTE

For operating instructions for the model of spray controller you have been supplied, refer to the controller manual supplied separately.

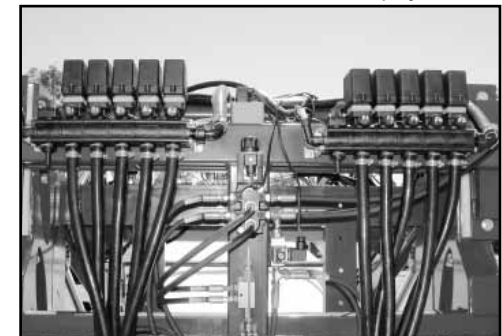

Dual line valves at the rear of the sprayer.

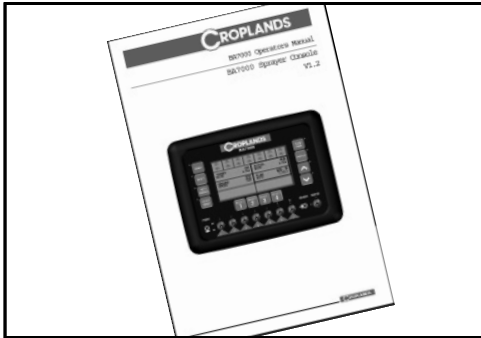

The BA7000 Manual.

For the operation of dual lines, you will need to refer to the BA7000 or ZYNX X20 Spray Controller manual supplied with your Pegasus Sprayer for full calibration and operational information.

Your BA7000 or X20 controller has been factory set to match the nozzles you have fitted to the Pegasus.



Mount the Foam Marker Controller in the cab.

5 Fit the Foam Marker Controller

The Foam Marker Controller has been fitted and fully tested at the factory but has been disconnected and packed for transit.

To fit the Foam Marker Controller:

- 1 Unpack the Foam Marker Controller and cables.
- 2 Mount the Foam Marker Controller in a convenient location in the tractor cab.

A Velcro strip has been provided for attaching it to a flat surface.

Cut the strip into four pieces, placing two strips face to face at each end.

You are free to choose your own hardware to secure the control box.



Connect the 4-pin plugs of the Foam Marker Controller.

- 3 Connect and lock the Foam Marker Controller 4-pin plug and loom 4-pin plug together.
- 4 Route the power loom from the cab to the battery.



Connect Foam Marker.

- 5 Connect and lock together the Foam Marker Controller loom couplings on the main harness.

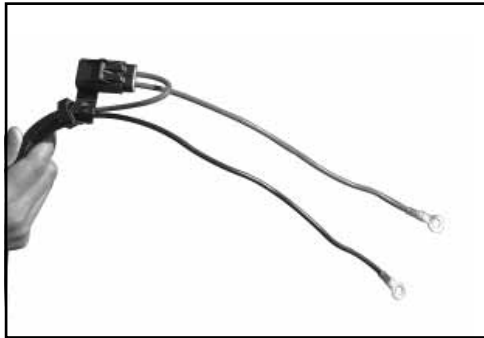

Connect the main harness cables to the battery.

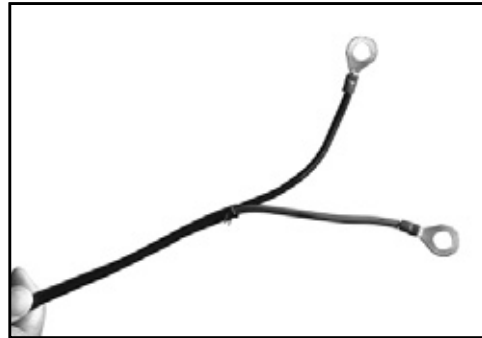

Connect the auxillary power cables to the battery (if fitted).



Air tank compressor.



Air chamber/tank.

6 Connect Power Leads to the Tractor Battery

Connect all power leads **directly to the battery**, namely the:

- Spray Controller leads
- Foam Marker Controller leads
- Electric/hydraulic control console auxiliary leads

Connect the Foam marker power cables to the battery (if fitted).

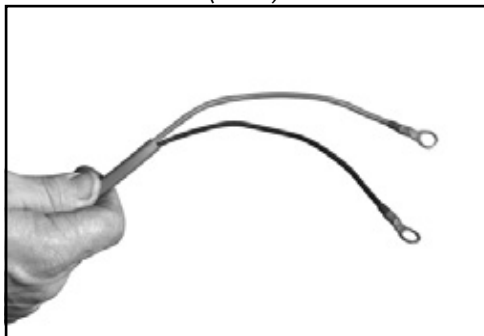

7 Activate the Airbag Suspension

To activate the Airbag Suspension follow the procedure below:

- 1 Engage the PTO.

The compressor will now pressurise the Pegasus air chamber, and raise the chassis.

Ensure air-tank drain valve is shut.

The system is fitted with a pressure relief which automatically bleeds air when the preset pressure is reached.

- 2 Remove the wooden transport blocks from each side of the chassis (if fitted).

! WARNING

Make absolutely certain that:

- Red leads are connected to the positive terminal, and
- Black leads are connected to the negative terminal.

Damage can occur to units if power leads are reversed or incorrectly fitted.

! WARNING

Before running the compressor for the first time, ensure the crankcase is filled with 20-40 oil to the CENTRE of sight glass. DO NOT OVERFILL.

If the optional dipstick is fitted, DO NOT FILL above the mark of the dipstick bottom stem. When checking oil level with dipstick, insert dipstick in place, DO NOT SCREW IT DOWN, lift out dipstick and check reading. Top up, if necessary.

Change oil after the first 30 hours of running, and every 100 hours after the initial running stage.

DO NOT USE FRICTION MODIFIED OILS, NEGLECT WILL VOID ANY WARRANTY.

Wooden transport blocks removed (if fitted).

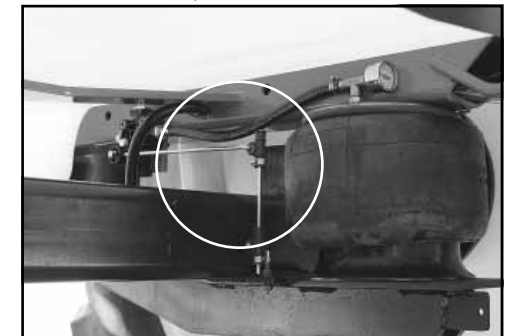

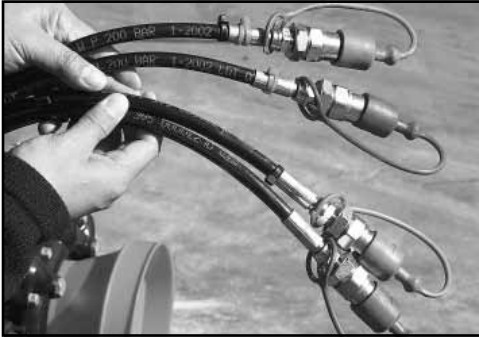

Disconnect hydraulic hoses & PTO shaft.

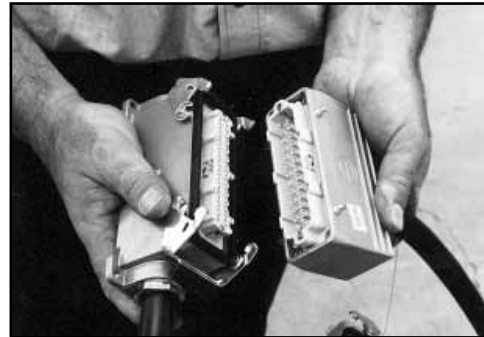

Disconnect the main loom coupling.

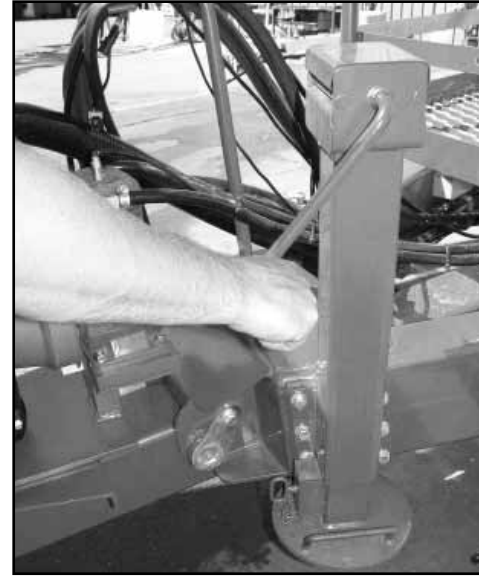

Unlock, unpin & wind down the hitch jack.

Unhitching the Pegasus from the Tractor

To disconnect the Pegasus sprayer from the tractor, follow the procedure below:

- 1 Ensure boom arms are in the folded position. **THIS IS IMPERATIVE FOR THE SAFE UN-HOOKING OF THE SPRAYER** (See Warning below).
- 2 Locate the sprayer on level ground and disconnect the:
 - PTO shaft,
 - Hydraulic hoses - for the boom and/or the hydraulic pump-drive,
 - All electrical looms,
 - Hydraulic hoses to filling pump (if fitted).
- 3 Unlock, unpin and wind down the hitch jack.
- 4 Pin & lock the hitch jack into position and, then, adjust the hitch height using the hitch jack.
- 5 Unlock and remove the tractor drawbar pin.

NOTE

Steps above must be performed on level ground.



WARNING

Boom arms *MUST* be in the folded position prior to parking and un-hooking the sprayer.

Failure to complete this operation correctly *MAY* result in *INJURY* or even *DEATH*.

NOTE

Fit dust covers to hydraulic remote connectors to avoid dirt/dust contamination.

The location of the Pegasus main control panel & other valves facilitates central, easy access of all control points for filling, mixing, spraying & cleaning functions:

Fill Control Lever
(4 operating positions):

- Off
- Fill Spray tank
- Fill Flush tank
- Fill Foam tank

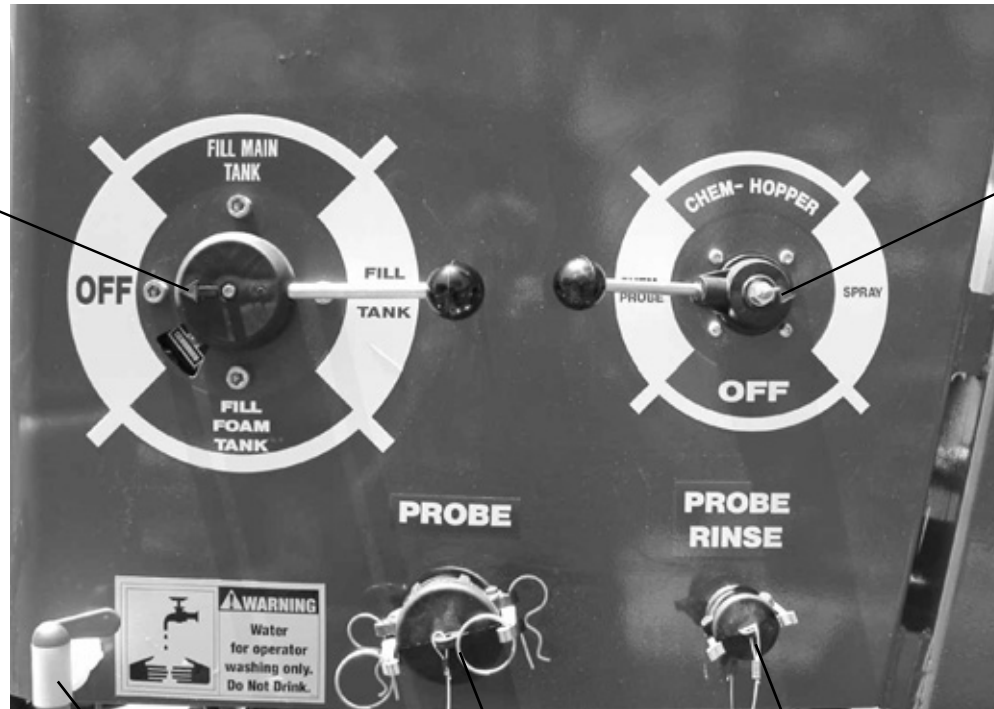

Pressure Control Lever
(4 operating positions):

- Spray
- Chem-E-Flush Hopper
- Chemical Probe
- Off

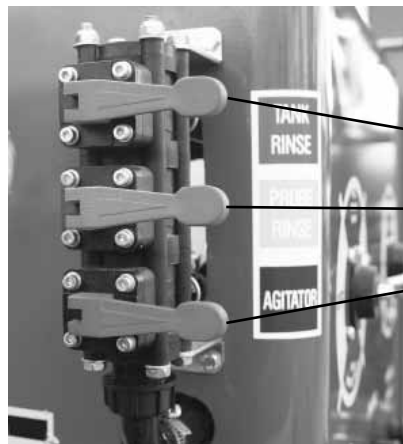

- Tank Rinse valve
- Probe Rinse valve
- Agitator valve
- Suction Line valve



- Chem-E-Flush Nozzle valve
- Chem-E-Flush Drum Rinse valve
- Chem-E-Flush Transfer valve

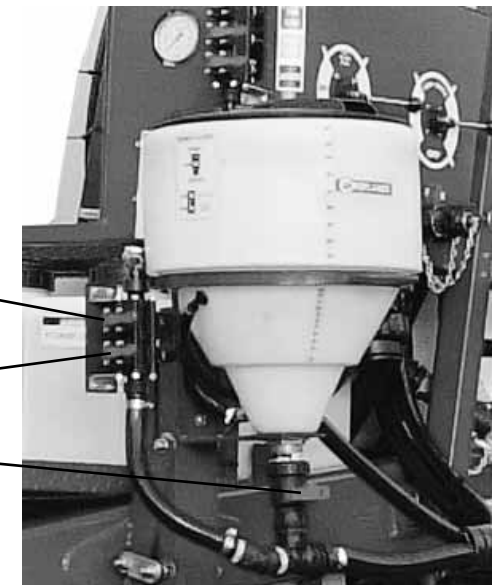

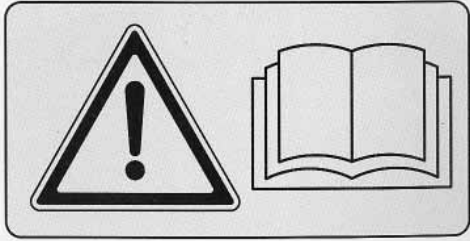

Read Operators' Manuals before operating machine.

Pre-Operation Check List

- 1 **Read Operator's Manuals thoroughly**, before attempting to use this machine.
- 2 Read and follow instructions on chemical manufacturers labels.
- 3 Always wear applicable protective clothing.
- 4 Check that all maintenance procedures have been followed.
- 5 Check all plumbing and fittings to ensure they are tight, not damaged or leaking.
- 6 Check PTO shaft is correctly set up (refer to page 14).
- 7 Grease the PTO shaft if necessary.
- 8 Check hydraulic connections.



Check pump oil level.

- 9 Check diaphragm pump oil level.

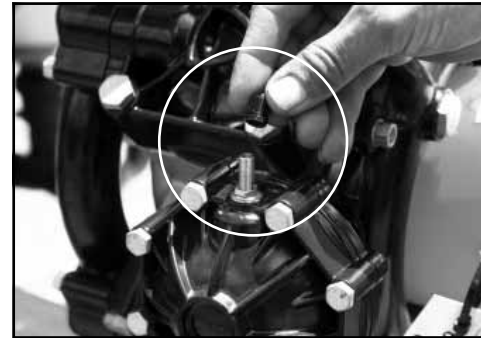

Check pump air chamber pressure.

- 10 Check air pressure in the diaphragm pump air chamber is 70 - 100 kPa (10- 15 psi).

As a general guideline it should be 10% - 20% of operating pressure.



Check the suction filter is clean.

- 11 Check the suction filter is clean.
Thoroughly clean the suction filter out after initial use.

NOTE

IMPORTANT: Clean the suction filter out after initial use.

Whilst all precautions are taken during assembly, it is possible to get fillings in the tank and lines. These will accumulate in the suction filter during first use.



Check the pressure filter is clean.



Airbag Suspension.



Check foam marker operates correctly.

11 Check the pressure filter is clean.

Thoroughly clean the pressure filter out after initial use, and nozzles if necessary.

12 If fitted, check the airbag suspension system is working correctly (Refer to "Check the Airbag Suspension" on page 2.18).

13 Check the foam marker operates correctly (Refer to Foam Marker operating instructions on pages 3.6, 3.7).

14 Check all Pegasus spraying functions (Refer to "Check the Spray Controller Operation" page 2.23; 2.24).

NOTE

IMPORTANT: Clean the pressure filter out after initial use.

Whilst all precautions are taken during assembly, it is possible to get filings in the tank and lines. These will accumulate in the filter during first use.



WARNING

Ensure wheel nuts are tight before every use.

Torque settings:

M18 x 1.5 Stud = 270Nm

M20 x 1.5 Stud = 380Nm

M22 x 1.5 Stud = 510Nm



MT3405 Controller standard.

Check the Spray Controller Operation

The automatic Spray Controller controls all aspects of the spray application rate.

Set the rates you want and the Controller ensures constant application rate - irrespective of undulating terrain, engine speed, ground speed and variations in nozzle wear.

To operate the unit:

- 1 Connect Pegasus to tractor (see instructions pages 2.10-2.18).
- 2 Fill an appropriate quantity of clean water into spray tank (see instructions pages 3.2-3.4).



Place the suction valve in "Spray" position.

- 3 Place the Suction Line valve in "Spray" position.

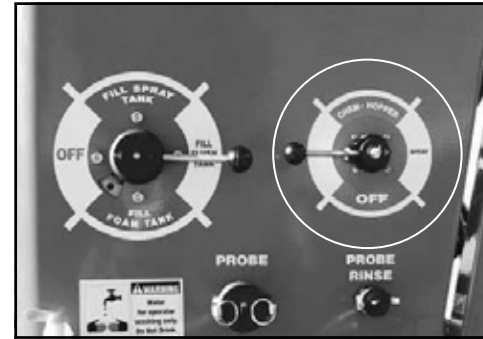

Rotate the Pressure Control Lever to "Spray" position.

- 4 Rotate the Pressure Control Lever to "Spray" position.

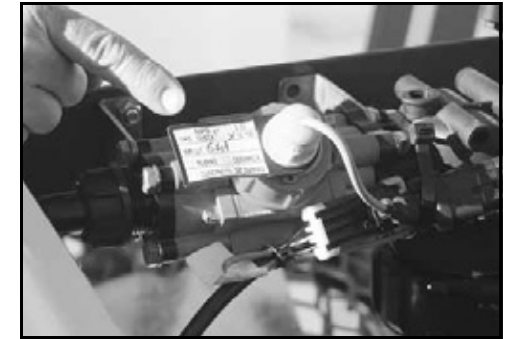

Enter the flow meter calibration factor.

- 5 Follow the instructions in the Spray Controller Instruction Manual - to calibrate and operate the Controller. If a X20 controller is installed, it will need to be charged prior to use. Refer to manufacturer's installation instructions for details.

- 6 Place the master switch of the Spray Controller in OFF position for start up. Ensure the controller power switch is ON.
- 7 Engage the PTO and bring the PTO (pump) speed up to 540 RPM.

In the case of a hydraulic drive, engage the appropriate hydraulic remote.

All pumped liquid is now being passed through the dump valve back into the tank. The system is not pressurised and tank agitators are not working.

- 8 Pressurise the system and operate the tank agitators.

! WARNING

Do not have pesticides in the spraytank when checking the sprayer.

NOTE

Additional copies of the Spray Controller manual can be downloaded in a PDF file format from the Internet.

For the micro-trak MT3405 or MT9000 controllers, log onto www.micro-trak.com and follow the menu.

For the Teejet 854, send an email with your request to teejetoz@spray.com and they will forward you a spare copy.

X20 Controller





Adjust the manual pressure relief valve.

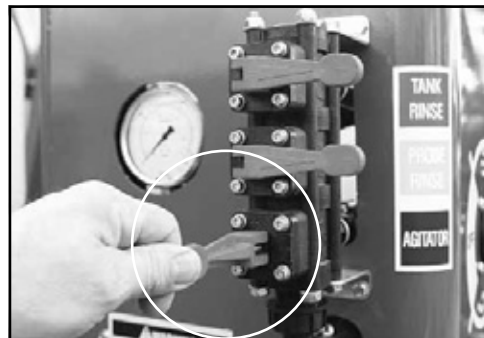

Check the tank agitator valve is open.



+/- keys and auto/man key.



Boom switches on, master switch in hold.

9 Adjust the spraying pressure as follows with the tractor & sprayer stationary:

- (a) On the Spray Controller, select the MANUAL mode using the appropriate key.
- (b) Switch on all boom valves, and switch the controller into the "RUN" position. Water will now be flowing out the nozzles.

It is recommended to do this with the boom open in the spraying position.

- (c) Use the "+" key on the Spray Controller to fully close the electric servo valve. This will take a few seconds.
- (d) When the servo is fully closed, adjust the manual pressure relief valve as shown to the maximum working pressure. In the case of the Pegasus, we recommend the maximum working pressure be set at 8 BAR (120 psi).

If the maximum pressure is above this, damage to your sprayer may result.

(e) Use the "-" key to reduce the pressure to your normal spraying pressure - 2-4 BAR (30-60 psi).

- 10 Check the tank agitator valve is open.
- 11 Visually check that both tank agitators are working.

12 Turn the Controller Master switch ON & OFF and check all boom sections switch off together.

13 Turn fenceline* nozzle ON & OFF to check it is working correctly (*if fitted)

14 While water is being pumped through the boom, check for any leakages or blockages throughout the sprayer.

Check all hoses, connections, valves, filters, boom fittings etc.

Check the nozzles are operating correctly.

Rectify any problems.

15 With all boom operating, re-check pressure range by alternating from "+" to "-" on the Spray Controller while in MANUAL mode.

Ensure maximum pressure does not exceed 8 BAR. Minimum pressure should reach almost zero.

16 Switch booms ON & OFF several times, ensuring each section is operating individually, and that the non-drip nozzle bodies are working.

17 On completion of checking the sprayer, turn controls Off by placing the master switch and boom switches in OFF position.

18 Disengage PTO or Hydraulic pump drive after the Spray Controller is switched off.

NOTE

The maximum spraying pressure will vary with different nozzles.

We recommend you re-adjust your maximum pressure if you change your nozzle selection.

Filling	3.2
Foam Marker	3.5
Filters	3.8
Cleaning	3.10
Boom Adjustment:	
- Boom Set Up - 24 to 30 metre	3.12
- Boom Adjustment - 36 metre	3.14
Boom Operation - All Sizes	3.17
Chemical Mixing	3.18
Airbag Suspension	3.24
Dual Lines	3.25
Operating Pointers	3.26

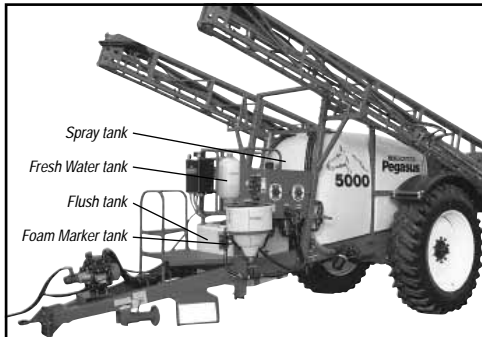

Open spray tank lid for top-filling.

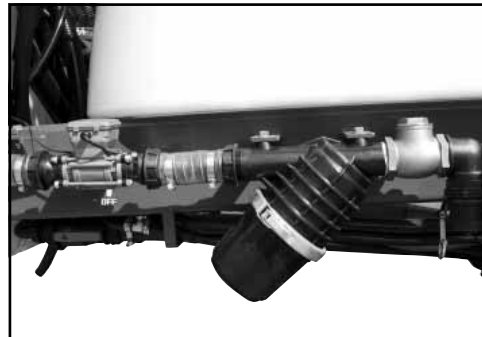

Clean the bottom fill filter.



Rotate the Fill Control Lever to "Fill Spray Tank" position.

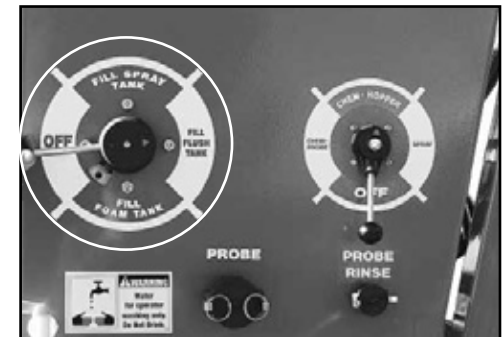

Rotate the Fill Control Lever to "Fill Flush Tank" position.

Filling the Pegasus Tanks

Three of the four Pegasus tanks can be filled by bottom-filling or via the top lid.

<u>Tank</u>	<u>Top Fill</u>	<u>Bottom Fill</u>
1 Spray tank	✓	✓
2 Flush tank	✓	✓
3 Foam Marker tank	✓	✓
4 Fresh Water tank	✓	x

Use clean, fresh water (preferably rainwater), free of suspended organic matter or clay. Some chemicals are deactivated when they contact these materials.

Always calculate the correct water quantity required, and when filling, allow sufficient water quantity for adding and mixing chemicals. If necessary top up the tank to required quantity after adding chemicals.

Use your preferred filling method.

Bottom-Filling

The bottom-fill facility requires a pressured water source and can be used to fill the spray tank, flush tank and foam marker tank.

To fill tanks using the bottom fill:

- Clean the bottom fill filter.
- Connect the filling hose to the bottom fill inlet connector.

- Rotate the Fill Control Lever to "Fill Spray Tank" position.

- Fill the Spray tank with the required amount of water.

- Rotate the Fill Control Lever to "Fill Flush Tank" position.

- Fill the Flush tank with water.

NOTE

*The Pegasus is fitted with a filling flowmeter.
Zero the filling flowmeter prior to filling.
See page 3.2 for instructions.*



Rotate the Fill Control Lever to "Fill Foam Tank" position.

- g) After filling the tanks, rotate the Fill Control Lever to "Off" position.
- h) Disconnect the filling hose and replace the bottom fill inlet cap.



Filling pump (if fitted).

Operating the Filling Pump

- a) Connect your filling hose from the water source (tank, filling station, dam etc) to the camlock coupling in the pump inlet
- b) Ensure the Hydraulic hoses for the filling pump are connected to the appropriate tractor remotes
- c) Turn on the hydraulic supply tap (see pic above right)
- d) Engage the appropriate tractor remote from the cab to start your filling pump.
- e) Filling can be interrupted by using the hydraulic supply tap at any time.

NOTE

On open-centre hydraulics, this will de-stroke the hydraulic pump on the tractor and allow you to pause the filling job.

If your remote disengages, to begin filling again you will need to open the hydraulic supply tap and re-engage the tractor remote lever or dial.

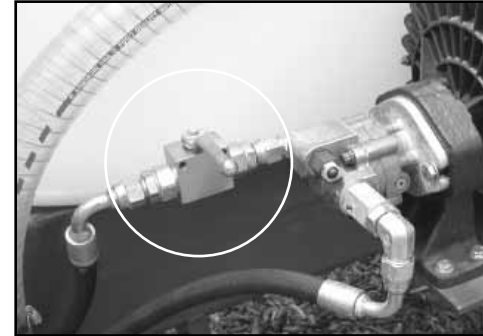

Hydraulic supply tap.

- f) Shut the hydraulic supply tap
- g) Un-hook your filling hose and store in the shed or on the sprayer



Orion filling flow-meter.

Operating the Orion Filling Flowmeter

Power is supplied from the main power harness, so no battery is required.

The Orion filling flowmeter is set in **Mode 1** at the factory. This allows the unit to be used as a flow-rate reader as well as a total flow meter.

An instruction book is included with your sprayer, and operation is described in section 5.2 (English instructions).

- a) Reset the digital display to zero before commencing filling - Page 29 of Orion booklet
- b) Fill the sprayer from the filling pump or your filling station. Instant flow reading can be indicated, or total flow reading - Page 29 of Orion booklet.

NOTE

On closed-centre hydraulics you will likely find the tractor will bypass hydraulic flow through the pressure relief valve and/or your remote will disengage.

If your remote disengages, to begin filling again you will need to open the hydraulic supply tap and re-engage the tractor remote lever or dial.



Open Spray tank lid for top-filling.

Top-Filling

All Pegasus tanks can be filled via the top lid.

1 Spray Tank

Use clean, fresh water (preferably rainwater), free of suspended organic matter or clay. Some chemicals are deactivated when they contact these materials.

Always calculate the correct water quantity required, and when filling, allow sufficient water quantity for adding and mixing chemicals. If necessary top up the tank to required quantity after adding chemicals.

To top-fill the Spray tank:

- a) Open the Spray tank lid and ensure the basket filter is in place.
- b) Fill the Spray tank with the required amount of water.
- c) Close and lock the tank lid after filling.



Open Flush tank lid for top-filling.

2 Flush Tank

Use clean, fresh water (preferably rainwater) in the 340 litre flush tank. Always fill the flushing tank before spraying.

To top-fill the Flush tank:

- a) Unscrew the flush tank lid.
- b) Fill the Flush tank.
- c) Replace & tighten the lid after filling.



Open Foam tank lid for top-filling/adding concentrate.

3 Foam Marker Tank

The Pegasus incorporates a 130 litre foam marker tank for minimal stops and maximum foam output.

Always use clean, fresh water (preferably rainwater).

To top-fill or add concentrate to the the Foam Marker tank:

- a) Unscrew the Foam tank lid.
- b) Fill the Foam tank with the required amount of water
- c) Replace & tighten the lid after filling.



Open Fresh Water tank lid for filling.

4 Fresh Water Tank

The Pegasus incorporates a 30 litre fresh water tank for personal safety when operating the unit in the field. Always fill the fresh water tank before spraying.

To fill the fresh water tank:

- a) Unscrew the tank lid.
- b) Fill the tank using only rainwater.
- c) Replace & tighten the lid after filling.



White foam concentrate.

Foam Solution

The performance of the the foam marker will depend greatly on using a high quality foam concentrate and good water quality.

Selecting a Concentrate

Always use high quality foam concentrate. We recommend Croplands brand White or Pink Foam for all general purpose marking.

Be aware that a lot of poor quality foam concentrate is sold every year to unsuspecting customers. Some concentrates may work well in some circumstances and not others, so be careful.

Water Conditioner

Croplands also offer a water conditioner if your water has a high mineral content.

If the foam appears watery, it may need more concentrate or a water conditioner. With some experimentation, you will easily find the right mix.



Pink foam concentrate.

Operating the Foam Marker

Mixing the Solution

The bottom-fill facility of the Pegasus allows concentrate to be added while filling.

Always add concentrate to water and not water to concentrate when top-filling.

When topping-up a tank of mix with a water hose, place the end of the hose under the surface so as not to agitate the solution causing the tank to fill up with foam. Always follow label directions.

Place a known volume of water in foamer tank. Measure out the required amount of foam concentrate and optional water softener and add to the tank.

It may be necessary to stir the tank to get the solution mixed. Normally the solution will be adequately mixed after transport to the field.



Make sure the foam marker liquid filter is clean.



Make sure air filter is clean



"Left (On) / Off / Right (On)" switch.



Foam density control knob.

Foam Marker Controller

The foam marker works by pumping air through the FoamTube™ on its way to the boom. Liquid is injected through an orifice into the air stream just prior to entering the foam mixing tube. A directional valve (on two sided models) then diverts the foam either left or right.

To operate the foam marker:

- 1 Make sure the foam liquid filter is clean and the tap is turned On after cleaning.
- 2 Make sure the air filter is clean.
- 3 Make sure the Foam tank tap is open.
- 4 To start the foam marker, move the switch either LEFT or RIGHT. The option of left or right selects which side you want the foam to go.
- 5 Rotate the foam control knob **fully clockwise** until pressure is indicated on the pressure gauge.
Turn knob **counter clockwise** until pressure is stable at 45- 50 psi.
It may be necessary to bleed air at the gauge.
- 6 Move the toggle switch to the "Left" position, and verify that the:
 - Foamer is making foam, and
 - Foam is flowing out of the LHS boom drop.
 Move the toggle switch to the "Right" position, and verify that the:
 - Foamer is making foam, and
 - Foam is flowing out of the RHS boom drop.
 If foam direction is opposite to the switch, reverse hoses at the foamer.
- 6 By rotating the pressure adjusting knob on the cab control, the operating pressure and foam density can be changed.
The higher the pressure the "wetter" and runnier the foam will be.
The lower the pressure, the "drier" and lighter the foam will be.
The mix ratio and water quality will significantly affect the pressure setting.
Experiment with various pressures and mixtures to find the one that is best for your conditions. Normal operating pressure is 35-55 psi.
- 7 Switch OFF the foam marker by placing the switch in the central (Off) position.
- 8 A Reset switch (resettable circuit breaker) on the Controller, allows resetting if a prolonged high current condition occurs.



The foam marker pressure gauge.

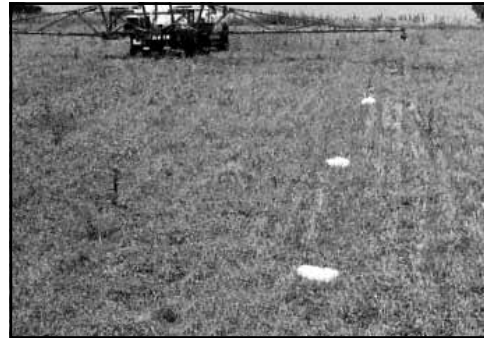

Adjusted for low foam output.



Adjusted for high foam output.

Setting Liquid Pressure

The foam marker injects the foam liquid mixture under pressure into the air stream to make foam. Liquid pressure is adjusted using the in-cab control (see page 3.6).

The foam control knob adjusts the relative mixture of air and water, which in turn controls the output and quality of foam.

The pressure gauge shows the pressure at which the liquid is being injected (higher pressure means more liquid is being injected into the air stream)

When the knob is turned fully **counter-clockwise**, the liquid pump is shut completely off. By rotating the knob **clockwise**, the pump will speed up, increasing liquid flow and liquid pressure will rise.

Adjust the pressure to obtain the best foam result for your conditions.

- Do not operate under 20 psi. It will often result in intermittent foam because there simply isn't enough liquid pressure to overcome the foam discharge pressure.

- Generally you won't operate over 55 psi as it will use excessive solution and create a very wet foam.

In very hot, dry conditions, it may be necessary to use very wet foam to increase the life of the foam.

Foam Pressure Setting Characteristic Chart

CHARACTERISTIC	LOW PRESSURE	HIGH PRESSURE
Pressure Range	20 to 30 psi	Above 30 psi
Foam Density	Light	Heavy
Foam Consistency	Fluffy, larger bubbles	Thick, smaller bubbles
Solution Usage	Lower	Higher
Average Blob Size	Larger	Smaller
Hot Weather Durability	Less	More

WARNING

Never operate the unit continuously over 60 psi. Operating continuously above 60 psi will overload the system and may cause damage.

WARNING

Air pressure is factory set at a maximum of 28 psi. Do not increase above 28 psi or damage may result.

WARNING

Always wear protective gloves when cleaning filters containing toxic chemicals.



Clean bottom-fill filter regularly.



Clean suction filter regularly.



Clean pressure filter regularly (Inset shows valve).

Cleaning Filters

Filters are used to stop solids entering the liquid system and blocking lines, nozzles or damaging the pump.

The Pegasus spray tank is fitted with a basket filter. The system incorporates large filling and suction filters, boom pressure filters, nozzle filters and a small filter is fitted to the foam marker.

- 1 Always ensure the basket filter is in place when filling the main tank through the lid.
- 2 All filters should be cleaned regularly or after each spraying period.

If the filter screen is damaged, replace with a new screen.

Bottom-Fill Filter

The bottom-fill filter should be cleaned regularly or before each filling of the spray tank.

To clean the bottom-fill filter:

- 1 Completely stop all sprayer functions.
- 2 Ensure the Fill Control lever is in "Off" position.
- 3 Remove the outer filter screw and bowl, and then remove the filter and thoroughly clean it before re-assembling the filter.

Suction Filter

The suction filter should be cleaned regularly or after each spray tank has been emptied.

To clean the suction filter:

- 1 Completely stop all sprayer functions.
- 2 Turn the Suction Line valve to "Off" position to shut Off liquid from the spray tank.
- 3 Remove the outer filter screw and bowl, and then remove the filter and thoroughly clean it before re-assembling the filter.
- 4 Return the Suction Line valve to "Spray" position.

Pressure Filters

The pressure line filter should be cleaned regularly or after each spray tank has been emptied.

To clean the pressure line filter:

- 1 Completely stop all sprayer functions.
- 2 Rotate the Pressure Control lever to "Off" position.
- 3 Open the valve at the bottom of the filter to ensure all pressure is removed from the filter.
- 4 Remove the outer filter bowl, and then remove the filter and thoroughly clean it before re-assembling the filter.

NOTE

Be careful not to damage or deform the mesh or O-ring while cleaning and refitting the filters.



Clean nozzle filters regularly.

Nozzle Filters

Nozzle filters should be cleaned regularly and when a nozzle spray pattern is effected by blockage.

To clean the nozzle filters:

- 1 Completely stop all sprayer functions.
- 2 Ensure all pressure is removed from the spray lines.
- 3 Remove the nozzle cap and nozzle, and then remove nozzle filter.

Thoroughly clean nozzle filter (and nozzle if necessary) before re-fitting the nozzle & nozzle cap.

- 4 Repeat step 3 for each nozzle.

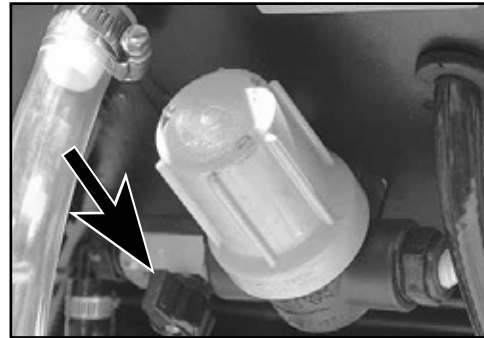

Close the filter tap & then remove the filter bowl.

Foam Marker Filters

The foam marker is protected by:

- A 50 mesh filter under the cabinet, &
- A 100 mesh filter located in the line before the liquid orifice.

These should be cleaned periodically, depending on cleanliness of operations.

To clean foam marker filters:

- 1 Completely stop all sprayer functions.
- 2 Close the tap next to foam marker filter (underneath the Outback cabinet).



After cleaning, replace the screen & filter bowl.

- 3 Remove the outer filter bowl, remove the filter (50 mesh) and thoroughly clean it before re-assembling the filter.
- 4 Re-open the tap next to the filter.

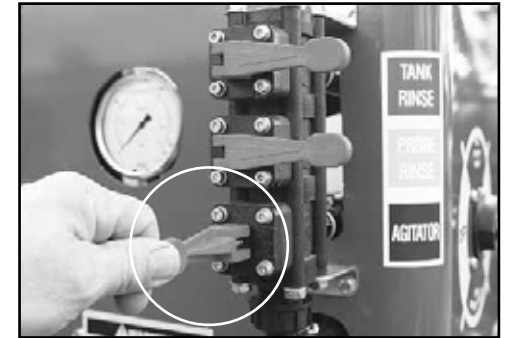

Ensure agitator valve is open before adding chemical.

Tank Agitation

When chemical is added to the spray tank, the pump and agitator(s) must be operating at all times to ensure chemical does not settle in the tank.

Check to see that tank agitation is correctly adjusted.

If agitation causes too much foaming in the tank, try closing Off one agitator to reduce foaming

If chemical settles, through pump break down or another reason, start up the sprayer after the fault has been rectified and let the mixture in the tank agitate for a length of time to ensure thorough mixing of the chemical.

NOTE

Be careful not to damage or deform the mesh or gasket while cleaning and refitting the filters and nozzle caps.

NOTE

*In some circumstances you may find the nozzle filters are best not used.
If your nozzle filters continuously block, check that your main pressure filter is not torn or that the product you are using is not the cause.*

NOTE

Be careful not to damage or deform the mesh or O-ring while cleaning and refitting the filters.



Open the Tank Drain valve to drain the tank.

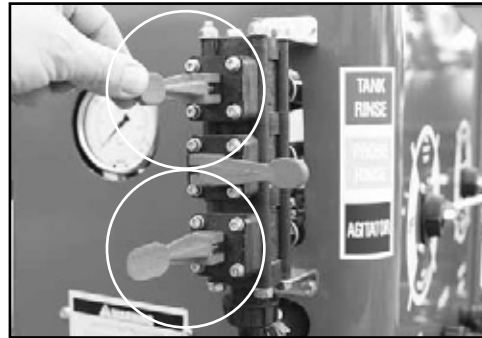

Open the Tank Rinse & Agitator valves.



Remove and clean the suction filter



Remove and clean the pressure filter

Flushing the Pegasus

The Pegasus is equipped with a flush tank for cleaning the sprayer when changing chemicals, and at the end of the day.

To flush the Pegasus:

- 1 Ensure the site for flushing and cleaning the Pegasus meets with environmental and statutory regulations.
- 2 Open the Tank Drain valve to drain any remaining spray mixture from the tank.
- 3 Check the Pressure Control lever is in "Spray" position.
- 4 Check the Agitator valve is open.

- 5 Open the Tank Rinse valve.
- 6 Turn the Suction Line valve to "Flush" position
- 7 Start tractor and place sprayer controls in start up position according to Controller operating instructions (see page 23).
- 8 Engage PTO/hydraulic drive and bring the pump speed up to 540 RPM.

All pumped liquid is now being passed through the dump valve back into the tank. The system is not pressurised and tank agitators are not working.

Turn the Suction Line Valve to "Flush" position.



- 9 Pressurise the system to operate tank rinse and agitators.
- 10 Adjust pressure to desired operating pressure by adjusting pressure up or down.
- 11 Turn the spray boom sections ON.

Fresh water now flushes through the suction line, suction filter, pump, agitator(s), pressure lines, boom sections and nozzles.

All water comes into the spray tank from the flush tank. Water remaining in the tank drains out of the tank through the drain outlet.

- 12 On completion of flushing, shut down all controls and disengage the PTO/hydraulic drive.
- 13 Remove and clean the suction filter & screen, and reassemble.
- 14 Remove and clean the pressure

- filter & screen, and reassemble.
- 15 Adjust all valves back to operating mode.
 - a) Close the Tank Rinse valve.
 - b) Turn the Suction Line valve to "Spray" position
 - c) Close the Tank Drain valve.
- 16 Wash/hose down the outside of the sprayer.

Close the Tank Drain valve.



NOTE

Ensure the drained mixture is disposed of as required by law. Read chemical instructions.

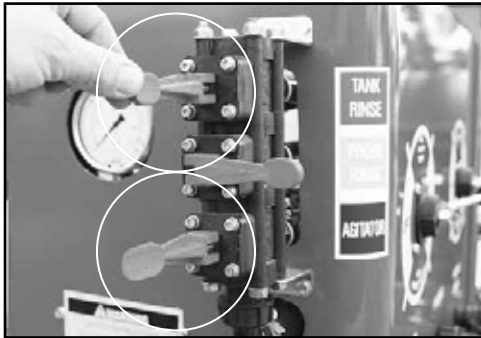

Open the Tank Rinse & Agitator valves.



Place the suction valve in "Spray" position.



Open the Tank Drain valve to drain the tank.

Using Tank and Equipment Cleaners

If a cleaning agent is required (refer to chemical label), first completely flush the Pegasus with water as outlined in Steps 1 - 16 on page 3.10, then:

- 1 Fill the spray tank with fresh water to the desired level.
- 2 Add cleaning agent into the main tank (use according to instructions).
- 3 Check the Pressure Control lever is in "Spray" position.
- 4 Check the Agitator valve is open.
- 5 Open the Tank Rinse valve.
- 6 Turn the Suction Line valve to "Spray" position
- 7 Start tractor and place sprayer controls in start up position according to Controller operating instructions (see page 2.24).

- 8 Engage PTO and bring the PTO speed up to 540 RPM.

All pumped liquid is now being passed through the dump valve back into the tank. The system is not pressurised and tank agitators are not working.

- 9 Pressurise the system to operate tank rinse and agitators.
- 10 Adjust pressure to desired operating pressure by adjusting pressure up or down.
- 11 Turn the spray boom sections ON.

Fresh water now flushes through the suction line, suction filter, pump, agitator(s), pressure lines, boom sections and nozzles.

- 12 If you require the cleaning agent to soak or stand for a period, turn the spray booms Off, and completely shut down the sprayer for a period.
- 13 Repeat steps 7 - 10 after soaking is completed.
- 14 Turn the spray booms OFF and shut down the sprayer.
- 15 Open the Tank Drain valve.
- 16 After the tank is drained, completely flush the Pegasus again following steps 1 - 16, on page 3.10.

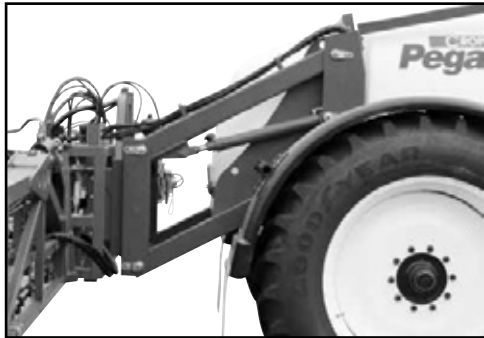

Unique parallelogram boom lift - low position.



Unique parallelogram boom lift - high position.

Boom Set-Up - 24-30 metre

The Compact boom hydraulically side folds and locks for transport. Unique parallelogram boom lift and suspension with hydraulic accumulator protects the boom and improves boom ride.

Adjustable boom breakaways with 90° self-returning boom ends and self levelling are standard.

Optional Hydraulic wing lift and/or independent wing-fold wing electric/hydraulic solenoid valves and an in-cab control are options (see page 2.14).

Boom set-up requires:

- 1 Wing alignment.
- 2 Wing extension alignment.
- 3 Balancing device alignment.
- 4 Backlash between sliding surfaces alignment.
- 5 Locking the balancing device adjustment.

To set-up the boom for operation, follow the instructions for the 21, 24, 28 and 30 metre compact booms and for the 33 & 36 metre booms.

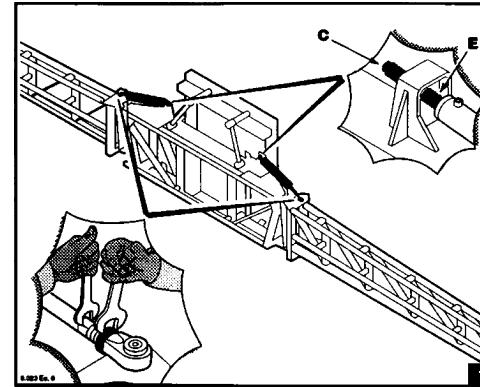

1 Wing Alignment

Wings are aligned to the central frame via the adjusting rods (C) shown in figure 1 (above).

To align wings:

- 1 Release pressure from the shock absorbers (A) shown in figure 2 (above right).
- 2 Align the wings by adjusting the cylinder rods shown in figure 1.
- 3 Once aligned, tighten the lock nuts on the cylinder rods.

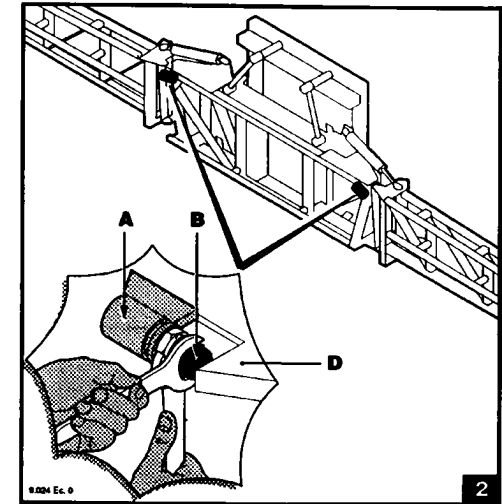

4 Adjust the shock absorbers (A), shown in figure 2 above, as follows:

- i) Tighten cap (B) against the limit stop (D) until springs are slightly pressurised.
- ii) Tighten the lock nut when adjustment is finalised.

NOTE

The initial boom alignment is carried out at the factory and checked by your dealer.

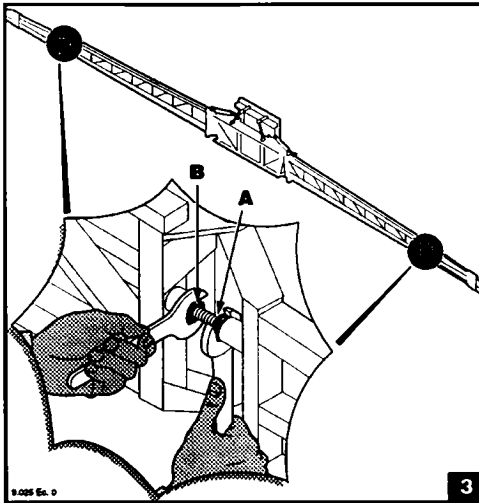

2 Wing Extension Alignment

After inner wing alignment is completed, align the wing extensions by:

- 1 Loosening the lock nuts B, shown in figure 3 above.
- 2 Tighten or loosen adjusting screws (A) until the wing extensions are aligned with the inner wings.
- 3 Tighten lock nuts (B), after alignment is finalised.

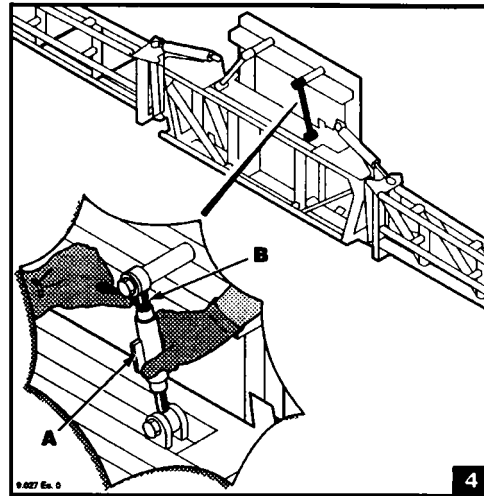

3 Balancing Device Alignment

The boom is fitted with an adjustable connecting rod which allows the boom to tilt $0^\circ \pm 3^\circ$ on the horizontal axis.

Adjust the boom to the require horizontal plane by:

- 1 Loosening the lock nuts (B,) shown in figure 4 above.
- 2 Turn the turnbuckle (A) as required.
- 3 Tighten the lock nut (B).

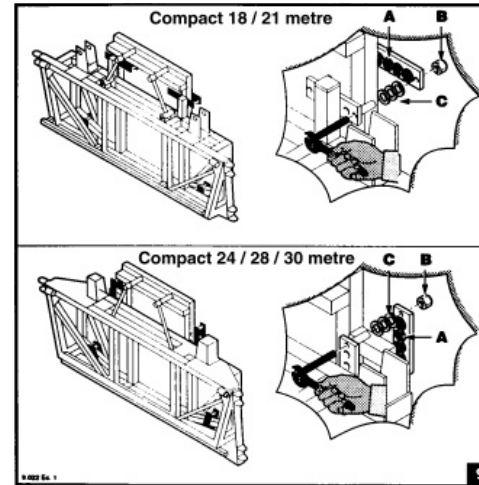

4 Backlash Between Sliding

The balancing device oscillation must be adjusted so that the surfaces slide freely and without backlash.

To eliminate backlash:

- 1 Tighten nuts (B), shown in figure 9 above.
- 2 If necessary, depending on wear of sliding pads (A), remove spring sections (C) as needed to take up the wear and remove backlash.

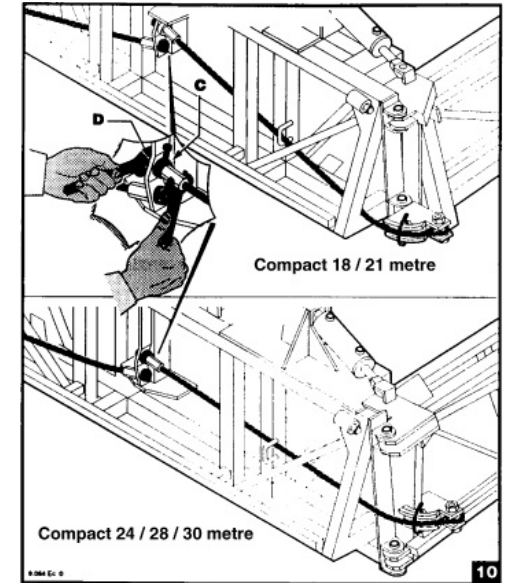

5 Locking the Balancing Device Adjustment

The ropes of the wing balancing device must be tight.

To adjust the balancing device:

- 1 Fold the wings to transport position
- 2 Tighten the ropes by adjusting the nuts (D), shown in figure 10 above.
- 3 Move the lock (C) closer and lock it with its screw.



Take the pressure off the boom by nudging the boom forward.



Adjust the nut, until the desired level is found.



Adjust the sleeve until the boom is at the desired level, then re-lock the lock nut to secure in place.



Finally, adjust the breakaway arm to the desired breakaway pressure.

Boom Adjustment - 36 metre

To adjust the boom alignments on your 36 metre boom on the Pegasus, follow the instructions.

These instructions are for adjustments you can do as the spring tensions change over time.

Not all steps may be necessary, but it is a good idea to check them as you make adjustments as required.

To adjust the boom:

Step 1: Horizontal Leveling

Take the pressure off the boom (as shown above left) using a forklift or other lifting mechanism. Make sure this is done on ground which is as level as possible.

a) First, adjust the main Boom arm Rod or Hydraulic ram (shown above) to set the boom to level.

For a G-Var wing lift boom, this is done by turning the large self locking nut with a large spanner on the spring end as shown until desired level is met.

You will need to have the hydraulic rams at maximum length to ensure an accurate setting.

For standard booms adjust the nut in the same place (as shown above left), until the desired level is found.

b) Secondly, relieve the weight from the boom. This adjustment is done using a turnbuckle. Unlock the lock nut so it is free from the sleeve.

Using a large spanner, adjust the sleeve until the boom is at the desired level, then re-lock the lock nut to secure in place (as shown above).

c) The final horizontal adjustment is the breakaway arm. Adjust this to the desired breakaway pressure.

NOTE

The initial boom alignment is carried out at the factory and checked by your dealer.

NOTE

Leave hydraulic pressure on extension side of ram to assist preventing rod from turning during adjustment.

Section 3

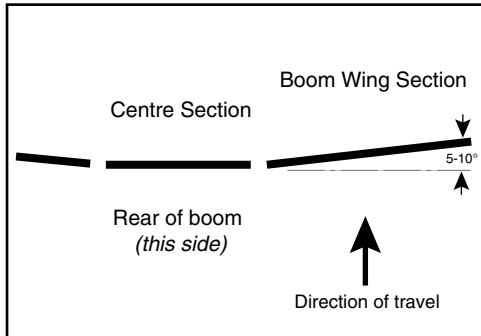

Ensure the boom wing is slightly forward in relation to the centre section (approx 5-10 degrees).

Step 2: Yaw adjustment

The second step towards accurately adjusting your boom is to set where the boom sits when fully opened into the spraying position.

This is the Yaw adjustment which means it is adjusted on a vertical axis or pivot point, setting the boom in a forward or backward direction.

The ideal position for each wing is slightly forward (approx 5-10 degrees) of the centre section (as shown in the diagram above).

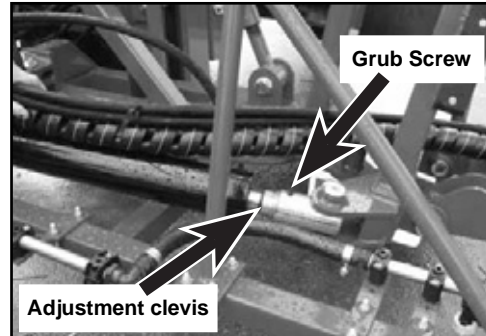

Remove the grub screws & adjust the clevis, then, return the grub screws to lock the setting in place.

- a) Adjust the clevis on the rod end of the inner fold ram at the centre section to bring the boom forward into desired position.

Firstly, you will need to relieve the pressure on the rams by loosening the ram fittings on one cylinder and releasing some oil.

Remove the grub screws and adjust the clevis to set the boom Yaw position.

Return the grub screws to lock the setting in place (shown above).



Set the bolt stopper to stop the boom at the position required.

- b) The next adjustment in the outer fold pivots is just a matter of winding out and locking the bolt in place as shown.

Set the bolt stopper to stop the boom at the position required (shown above).



Lock the nuts in place when set correctly.

- c) Set the breakaway position by tightening and loosening the matching bolts on either side of the boom.

Lock the nuts in place when set correctly (shown above).

CAUTION

When releasing oil from and cylinders, be sure to cover the fittings with a cloth to prevent oil from spraying out, as it is hazardous.



Adjust the turnbuckle sleeve until the centre section is level.

Step 3: Boom tilt adjustment

The next setting is the tilt adjustment which dictates the level position of the booms and centre section as a whole. This is very important to get right so that the centre section is level before spraying.

To adjust undo the lock nut on the turnbuckle.

Adjust the turnbuckle sleeve (*as shown above*) until the centre section is level.

Lock the nut back in place to secure the setting.

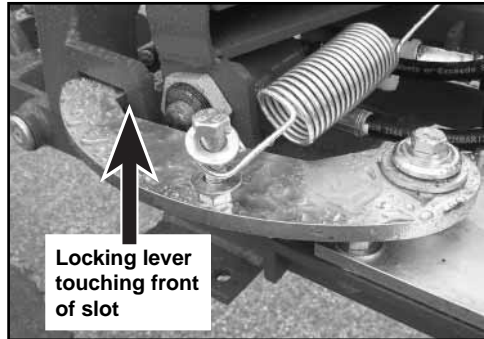

When locked the hook part of the locking lever should be in contact with the front edge of the slot.

Step 4: Outer arm locking plate

The final setting is the outer arm locking plate. This is to keep the boom locked in place while spraying.

When locked the hook part of the locking lever should be in contact with the front edge of the slot (*as shown above*) to ensure no movement during spraying.

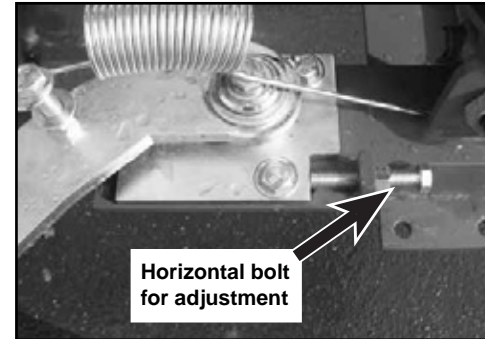

Loosen the lock nuts and then adjust the horizontal bolt to position the plate in the correct setting.

To adjust this, loosen the lock nuts and then adjust the horizontal bolt (*shown above*) to position the plate in the correct setting.

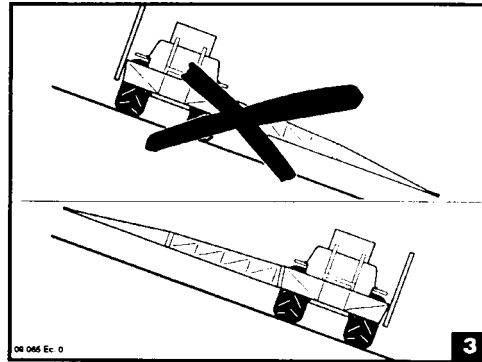

Boom in raised position.



Boom in lowered position.

Unfolding & folding the Spray Boom

Understand the safety precautions below before operating the folding mechanism of the spray boom.

DANGER - WARNING:
 Make sure there are no people, things or power lines with in range of the spray boom when folding or unfolding

CAUTION:
 If working on steep terrain, please note the following:

- Lock the balancing device (if the unit is provided with hydraulic locking).
- For vehicle stability, always unfold the up hill side boom before unfolding down hill side boom, see figure 3 above .
- For vehicle stability, always fold the down hill side boom before folding up hill side boom.
- Never operate with the down hill side boom lowered and up hill side boom folded.

To operate the boom:

- 1 Use the tractor remote controls to fold and unfold the spray boom.
- 2 Use the tractor remote controls to raise and lower the spray boom height as required.

! WARNING

Make sure there are no people, things or power lines with in range of the spray boom when folding or unfolding

! CAUTION

If working on steep terrain, please note the following:

- *Lock the balancing device (if the unit is provided with hydraulic locking).*
- *For vehicle stability, always unfold the up hill side boom before unfolding down hill side boom, see figure 3 above .*

! CAUTION

If working on steep terrain, please note the following:

- *For vehicle stability, always fold the down hill side boom before folding up hill side boom.*
- *Never operate with the down hill side boom lowered and up hill side boom folded.*



Accurately calculate the amount of chemical required.



Unlock the Chem-E-Flush with the foot latch.



Lower hopper into the filling position.



Rotate the Pressure Control lever to "CHEM-HOPPER".

Calculate Water & Chemical Quantities

Before spraying it is necessary to calculate the exact quantities of water and chemical needed to spray the required area. The following formulae may be useful:

- 1 For chemical rates expressed in litres or kg per hectare (land area), calculate the amount of chemical needed, using the formula:

$$\text{Chemicals required (litres)} = \frac{\text{Tank Volume (l)} \times \text{Recommended Chemical Rate (l/ha)}}{\text{Spray Application Rate (l/ha)}}$$

eg. $[4000 \times 3] \div 150$
= 80 litres.

- 2 For volume of mixture required to spray the selected area, calculate the liquid required, using the following formula:

$$\text{Tank Volume Required (litres)} = \text{Area (ha)} \times \text{Spray Application Rate (l/ha)}$$

eg. 300×150
= 45,000 litres

- 3 For area covered by a given volume of mixture, calculate the area, using the following formula:

$$\text{Area Covered (ha)} = \frac{\text{Tank Volume (litres)}}{\text{Spray Application Rate (l/ha)}}$$

eg. $4000 \div 150$
= 26.7 hectares

NOTE

IMPORTANT! Be sure to mix only enough spray mixture to cover the area required. Avoid wastage and problems of needless chemical disposal.

Adding Chemical To the Spray Tank

Chemical can be added to the spray tank using the Chem-E-Flush hopper, and/or if fitted, the optional Chemical Probe.

1 Chem-E-Flush Hopper

To add chemical to the spray tank, follow the steps outlined:

- a) Make sure sufficient water is added to the spray tank and the flush tank.
- b) Unlock the Chem-E-Flush dropdown leg lock by placing your foot on the latch lever. Hold on to the handle and pull out and down once the latch is released.

- c) Lower the hopper to filling position.
- d) Rotate the Pressure Control lever to "Chem-Hopper" position.
- e) Turn the Suction Line valve to "Flush" position.

Turn the Suction Line Valve to "Flush" position.



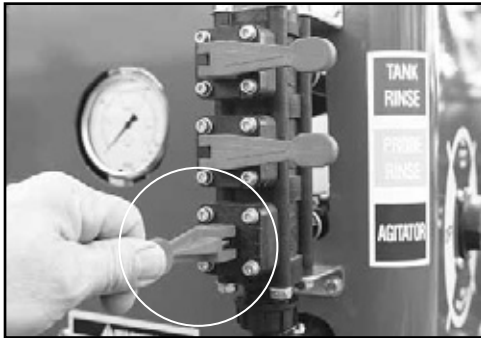

Open the Agitator valve.



Open hopper lid & add chemical powder/liquid.

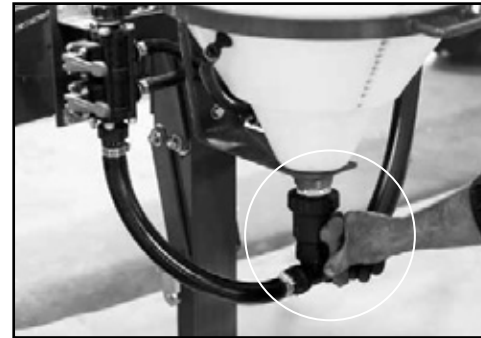

Open the Transfer valve to transfer the mixture.

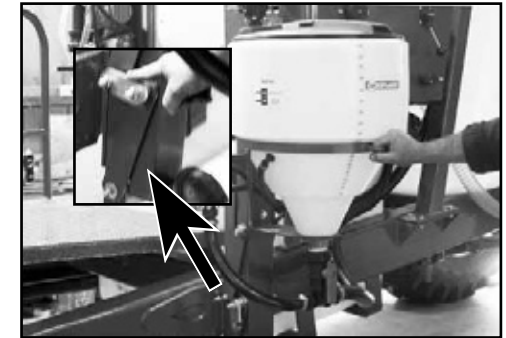

Lift the hopper & lock it back into transport position.

- f) Open the Agitator valve.
- g) Close the Chem-E-Flush Transfer valve at the base of the hopper.
- h) Start the tractor and **operate the pump with PTO & tractor engine at idling speed only.**
Warning! Operating the pump at faster than idling speed, may burst lines.
- i) Pressurise the pressure lines by switching the spray controller ON & in RUN mode with booms OFF.

- j) Open the hopper lid & add chemical powder/liquid to the hopper.
- k) Close the hopper lid & open the Chem-E-Flush Nozzle valve to mix chemical.
- l) Close the Chem-E-Flush Nozzle valve after the chemical is mixed.

- m) Open the Chem-E-Flush Transfer valve at the base of the hopper to transfer chemical mixture to the spray tank.
- n) To rinse the hopper, close the Chem-E-Flush Transfer valve at the base of the hopper and open the Chem-E-Flush Drum Rinse valve.

- o) To transfer the rinse mixture to the spray tank, open the Chem-E-Flush Transfer valve at the base of the hopper.
- p) After rinse mixture has been transferred:
 - Close the Chem-E-Flush Transfer valve at the base of the hopper.
 - Rotate the Pressure Control lever to "Spray" position.
 - Turn the Suction Line valve to "Spray" position
- q) Lift the hopper back to transport position when mixing is completed.
- r) Lock the Chem-E-Flush dropdown leg lock by pushing the hopper up hard enough to engage the latch mechanism.

Close transfer valve at the base of the hopper.



Close hopper lid & open the Chem-E-Flush Nozzle valve to mix chemical.

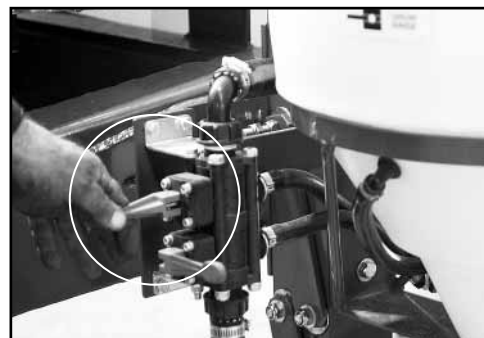

Close transfer valve & open the Drum Rinse valve to rinse the hopper.



NOTE

IMPORTANT! Ensure agitation of spray tank continues after chemical is added to the spray tank.



Connect Probe & Probe Rinse hoses.



Turn the Suction Line Valve to "Flush" position.



Open Probe valve to transfer mixture to spray tank.



Close probe valve.

2 Chemical Probe

To add chemical to the spray tank using the chemical probe (optional), follow the steps outlined:

- a) Make sure sufficient water is added to the spray tank and the flush tank.
- b) Connect the Probe and Probe Rinse hoses to the connectors (on the control panel).
- c) Rotate the Pressure Control lever to "Chem-Probe" position.

- d) Turn the Suction Line valve to "Flush" position
- e) Open the Agitator valve.
- f) Open the Probe Rinse valve.
- g) Start the tractor and **operate the pump with PTO & tractor engine at idling speed only.**
- h) Place the probe in the chemical and open the Probe valve to transfer chemical to the spray tank.
- i) Use the Probe Rinse gun to rinse the container while the Probe valve is open.

- j) Close the Probe valve when the chemical transfer is completed.
- k) Close the Probe Rinse valve.
- l) Rotate the Pressure Control lever to "Spray" position.
- m) Turn the Suction Line valve to "Spray" position
- n) Disconnect the Probe and Probe Rinse hoses and refit the connector caps.

⚠ WARNING

Operating the pump at faster than idling speed may burst lines.

Rotate the Pressure Control lever to "Chem-Probe"

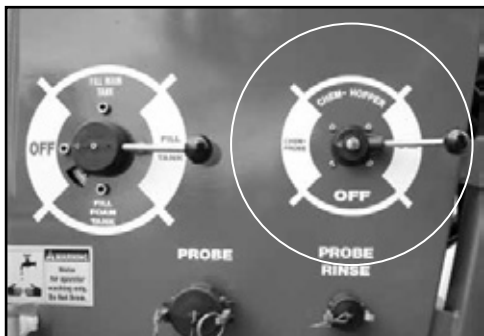

Open the Agitator and Probe Rinse valves.

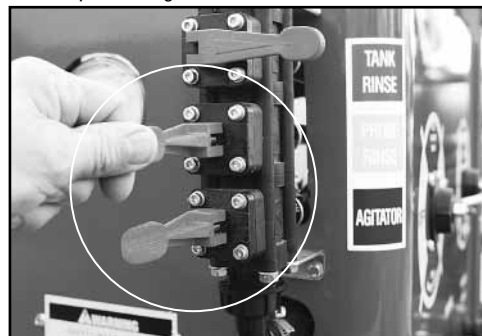

Use the Probe Rinse gun to rinse the container.



NOTE

IMPORTANT! Ensure agitation of spray tank continues after chemical is added to the spray tank.



Unclip the Micromatic fitting from its docking point.



Turn the rotary selector to "Chem Hopper".

Enviro-transfer Kit

The Enviro-transfer kit is a volumetric filling system designed to transfer chemicals directly from Envirodrums into the Chem-e-flush mixer/induction unit on the Pegasus.

If using a closed centre system hydraulic pump as explained on page 2.15, you can OPEN the control valve to slow down the enviro-transfer speed.

Remember to close the valve and check the pump speed after transfer is complete.

Step 1

Unclip the Micromatic fitting from the docking fitting on the sprayer and clip it into the Envirodrum containing the chemical you intend to use.

Step 2

Turn the rotary selector on the main control panel to "Chem Hopper".

Ensure the Chem-e-flush is empty of any liquid or residue before progressing.

The Chem-e-flush can be left in the "up" position during the following process. It is not necessary to lower the drop-leg.

Step 3

Engage the PTO to start the main spray pump operating at low revs.

DO NOT OPERATE AT FULL REVS.

If you are operating a hydraulic drive on the pump, turn down the hydraulic flow to slow the pump down temporarily.

WARNING

The operator must not leave the Enviro-transfer kit unattended while filling. Over-filling and chemical spillage could result if the unit is unattended during the transfer process.

The system is only suitable for liquid transfer.

Clip the Micromatic fitting into the Envirodrum.



CAUTION

Do not operate the pump at full speed when filling with the Enviro-transfer, otherwise damage to plumbing may result.



With the pump running, turn the two taps into the Enviro-transfer position.

Step 4

With the pump running, turn the two taps (pictured) from the normal spray position to the Enviro-transfer position.

The Enviro-transfer position is marked with two white cable ties as shown.



Watch the level closely - maximum fill is 50 litres.

Step 5

Once the taps are in the correct position, the chem-e-flush will begin to fill the **immediately**. Watch the level closely.

Once the level you require is reached, **shut off the flow by turning the two taps back to the original position simultaneously**.

NOTE

The chem-e-flush can hold a recommended maximum of 50 litres in one fill.

Note the two white cable tie which show the direction of the taps for the Enviro-transfer.



When the required level is reached, simultaneously turn the two taps back to their original position to stop flow.

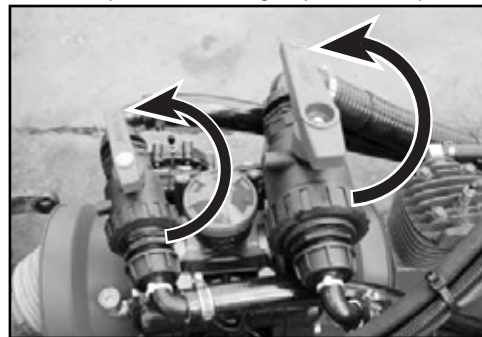

Turn the Chem-e-flush tap to introduce the chemical directly to tank (as shown).

Step 6

Check the level of your selected chemical in the Chem-e-flush is correct. If so, turn the tap on the bottom of the Chem-e-flush to introduce the chemical directly to tank (as shown above).

Flush the Chem-e-flush with water after the contents of the mixer have been introduced to the main tank.

For full instructions on the Chem-e-flush (see pages 3.18 & 3.19).



Unclip the Micromatic fitting from the Envirodrum.

Step 7

Unclip the Micromatic fitting from the Envirodrum and clip it back into the docking fitting.

Ensure it is fully located.

Clip the Micromatic fitting back into the docking fitting.



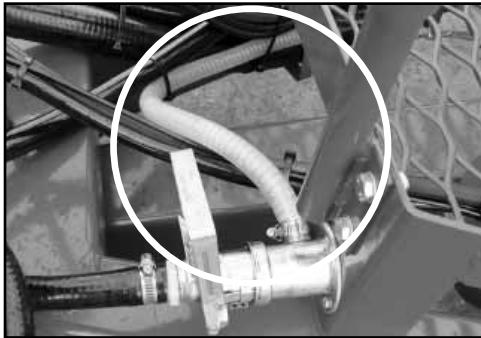

A fresh water hose allows the Micromatic fittings to be flushed after use.

Step 8

The docking fitting has a flushing hose plumbed direct to the fresh water tank.

By turning the two taps on top of the pump back to the Enviro-transfer position for approximately 30 to 60 seconds, you can flush the Micromatic fittings and the hose with fresh water.

This is imperative to avoid any future contamination.

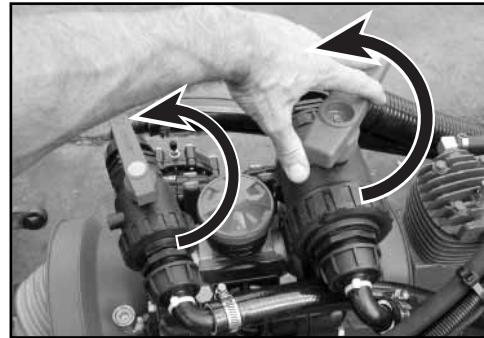

Return the two taps to the normal spray position.

Step 9

Return the two taps to the normal spray position after step 8 is completed.



Return the main rotary selector to the "Spray" position.

Step 10

Return the main rotary selector to the "Spray" position.

Ensure the tap on the bottom of the chem-e-flush is shut off.

It is recommended you leave the PTO engaged to ensure your chemicals are agitating/mixing correctly in the main tank.

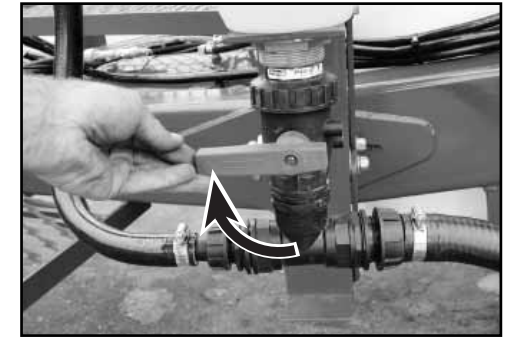

Turn-off the tap on the bottom of the Chem-e-flush.

Turn the taps for the Enviro-transfer to flush the Micromatic hose and fittings.

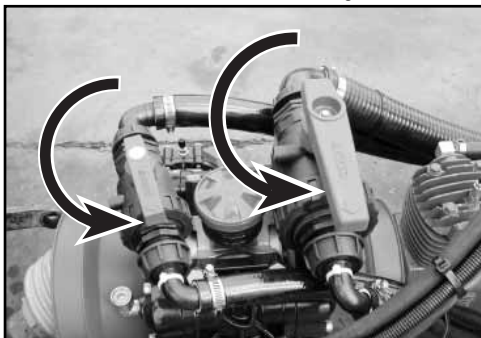

CAUTION

Always flush the Micromatic fittings & hose with fresh water after each use to avoid any future contamination.

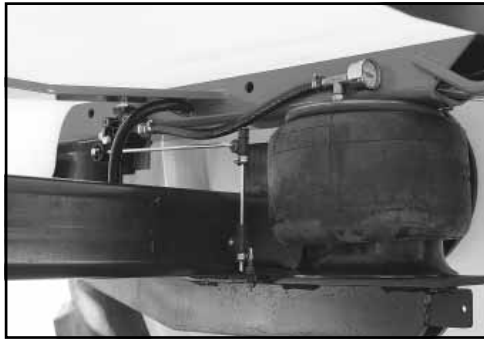

Airbag suspension system.



Unladen airbag ride height is pre-set to 220mm.

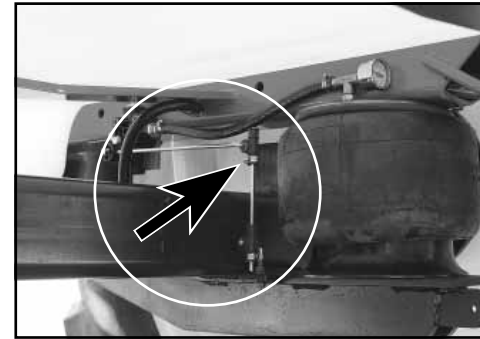

Slacken the clamp on the vertical vertical rod.

Check the Airbag Suspension

The Airbag Suspension comprises a compressor, air tank, airbags and height levelling valves.

When filling the sprayer with water the airbag suspension automatically increases the pressure in the air bag to carry the extra load.

Conversely, as the spray tank is emptied, the airbag suspension automatically decreases the pressure in the air bag adjusting to the lighter load.

On hillsides, more pressure automatically inflates the lower side airbag which improves stability.

Airbag Ride Height

The ride height of the airbag is factory pre-set to approximately 220mm from the top plate to the bottom plate of the airbag.

The ride height under load should be set to 230 - 240mm.

Airbag Valve operation

The airbag valves operate by increasing or decreasing air pressure in the airbags to compensate for the existing load.

- 1 Move the horizontal rod up - air should flow into the airbag.
- 2 Move the rod to horizontal - air flow should stop.
- 3 Move the horizontal rod down - air should flow out of the airbag.

Airbag Pressure Adjustment

To raise (increase pressure in) an airbag:

- 1 Slacken the clamp on the vertical valve rod, and
- 2 Raise the end of the horizontal rod slightly (about 20mm).

Air will be heard entering the bag through the valve.

- 3 When the bag pressure is even, return the rod to horizontal position and retighten the clamp.

To lower (decrease pressure in) an airbag:

- 1 Slacken the clamp on the vertical valve rod, and
- 2 Lower the end of the horizontal rod slightly (about 20mm).

Air will be heard leaving the bag through the valve.

- 3 When the bag pressure is even, return the rod to horizontal position and retighten the clamp.

NOTE

The air chamber is automatically charged by the compressor to a pressure of 95 psi. Pump drive is required for the compressor.

When air chamber pressure drops the compressor automatically recharges the chamber to 95 psi. Excess air is automatically bled from the air tank.



Dual lines on the boom.

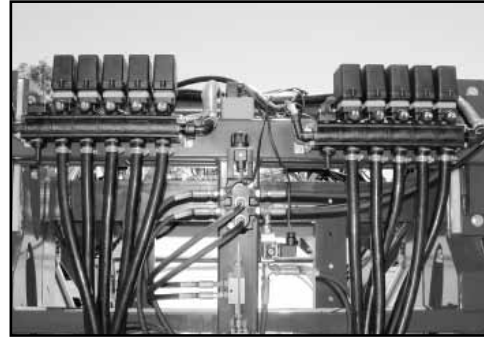

Dual line valves at the rear of the sprayer.

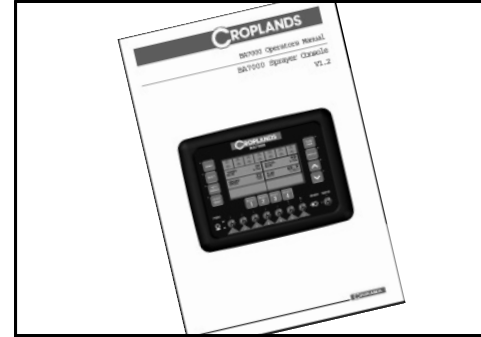

The BA7000 Manual.

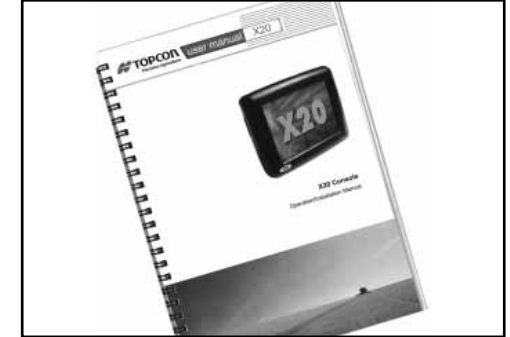

X20 Manual.

Dual Lines

If you have chosen dual lines to be fitted to your sprayer, you will be familiar with the use of this option on your Pegasus sprayer. In general terms, there are usually two reasons to have dual lines fitted:

- 1 To increase the boom output using the same speed setting by introducing a second boom line - this negates the need to change nozzles to perform this task, and

- 2 To increase the speed range available for your sprayer by having the second boom line cut in/out at a given speed.

For the operation of dual lines, you will need to refer to the BA7000/X20 Controller booklet supplied with your Pegasus Sprayer for full calibration and operational information. Your BA7000/X20 controller will have been factory set to match the nozzles supplied and fitted to your Pegasus.

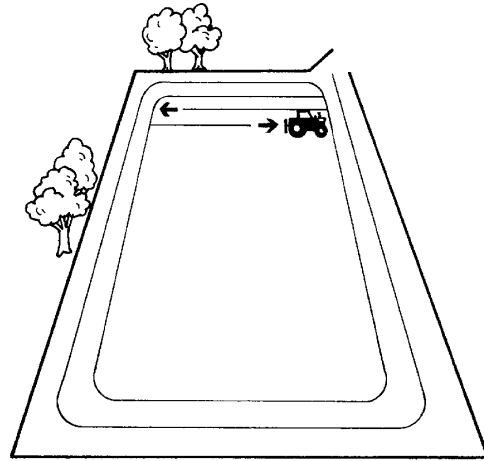

Operating Methodology for Broadacre Spraying

It is always preferable to spray travelling across the wind direction.

This minimises any drift effect caused by the wind especially with flat fan nozzles because the wind only hits the narrow end of the pattern rather than the full face of the fan spray.

It also maximises the effect of the wind forcing droplets downwards into contact with the target.

Travelling with the wind increases the tendency of spray droplets to float away from the target, and travelling against the wind effectively multiplies the force of the wind (depending on speeds) increasing drift and reducing target contact.

Proceed to Spray

Once the chemical mixture is in the tank, proceed to spray:

- 1 Adjust the pressure to the correct operating pressure by adjusting pressure (up or down) according to the instructions of the Controller.
- 2 Turn spray booms ON and OFF as required to spray according to the instructions of the controller fitted.

Refer to pages 2.23 - 2.25 for spray controller operating instructions, and page 3.6 for foam marker operating instructions.

Operating Pointers

While spraying, continually observe that:

- 1 Engine and PTO speed are correct.
- 2 Correct operating pressure is being maintained.
- 3 Ground speed is correct and within the operating range of the nozzles and application rates selected.
- 4 Pegasus spray heads are operating correctly and aimed toward the targeted foliage.

CAUTION

Running a diaphragm pump faster than specified will not improve performance, but will damage and wear out moving parts.

Warranty will be made void by speeds in excess of those indicated on the pump name plate.

Calibration Procedure	4.2
XR & AI TeeJet Nozzle Chart	4.9
Air-Mix & Turbodrop® Nozzle Chart	4.10
Calibration Work Sheet	4.12



Proper calibration considers all spraying variables.

Applying the correct amount of chemical to a crop is only possible if:

- the sprayer is calibrated correctly.
- the sprayer is operated correctly.
- the sprayer is maintained correctly.

The variables of spray application (distance, time, working width, liquid and chemical volumes) must be measured and controlled accurately to ensure chemicals are applied at the correct rate.

The automatic spray controller measures and controls the variables of speed and flow rate to give constant application.

However proper nozzle selection, checking calibration of nozzles, speed and flow rate as well as correct mixing of chemicals must be done to ensure the accuracy and performance of the sprayer and its controller.

Accurate calibration is essential to ensure uniform application of the recommended dose of chemical to the target.

Proper calibration involves setting up the sprayer (nozzle selection, pressure, speed), calculating chemical and water rates and measuring the performance of the sprayer itself. Only then can you be totally confident in applying chemical correctly.

Fully Automatic Spray Controller

The fully automatic spray controller maintains the application rate (set by the operator) when operated in Auto position.

The controller monitors speed of travel (speed sensor) and flow rate (flow meter) and automatically adjusts flow rate (via a servo valve) to maintain correct application rate irrespective of speed variations within the limits of the nozzles used.

IMPORTANT:

- 1 It should be remembered that the spray controller does not eliminate the necessity to measure and check the accuracy of nozzle spray patterns and outputs. These must be checked regularly to ensure correct and uniform application rates because nozzles wear with use.
- 2 Flow meters used by the controller also needs to be checked and calibrated on a regular basis.

On the following page, you will see how to maintain and check your Rapid-check flowmeter. It is recommended you do this regularly during the spraying season.

See the Controller Operator's Manual for detailed information and calibrating procedures specific to your spray controller.



Rapid Check Flowmeter

Calibration Procedure

For accurate spray rate application, follow this calibration procedure:

Step 1 Ensure Equipment Is In Good Working Order.

Tank, pump, boom, filters and nozzles must be clean, free of leakages and functioning properly.

Follow the pre-operation checklist, maintenance and operating instructions in this manual.

Install, calibrate and operate the spray controller according to the spray controller Installation/Operators Manual.

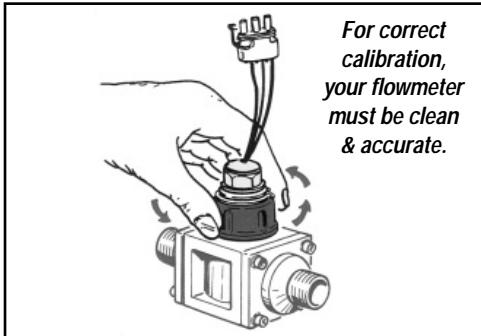

For correct calibration, your flowmeter must be clean & accurate.

Unscrew the the Rapid Check assembly.

Daily Check & Maintenance of Flowmeter

This is to be performed every day after work is finished:

- 1 Unscrew the assembly that holds the Rapid Check unit in the body.
- 2 Remove the Rapid Check unit from the body.

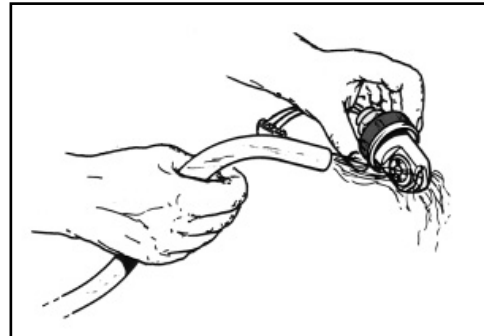

Wash any impurities out of the removable turbine unit.

- 3 Use clean water to wash any impurities out of the removable turbine unit.
- 4 Use compressed air to verify that the turbine unit rotates freely (maximum air pressure 1 BAR [15 psi]).

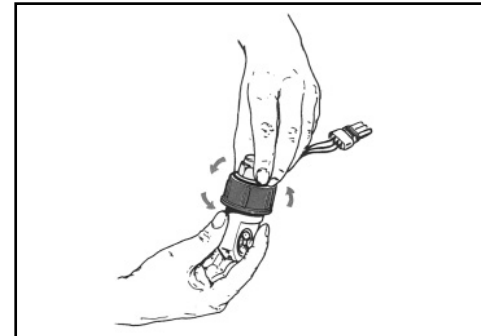

Unscrew the sensor.

Every 50 Hours

Carry out the following procedure after every 50 hours of operation:

- 1 Unscrew the sensor.
- 2 Separate the sensor from the Rapid Check unit.

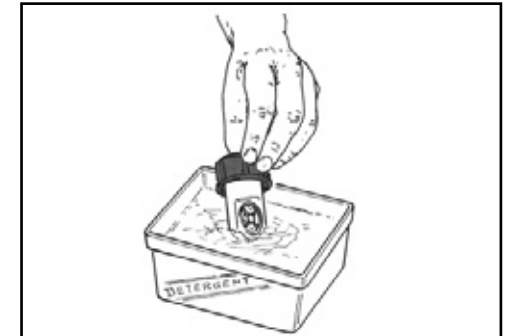

Place the Rapid Check unit in a detergent bath.

- 3 Place the Rapid Check unit in a detergent bath for a few hours.
- 4 Remove the Rapid Check unit from detergent bath.

Use compressed air to verify that the turbine unit rotates freely (maximum air pressure 1 BAR [15 psi]).

If necessary, replace the Rapid Check unit with a new one.

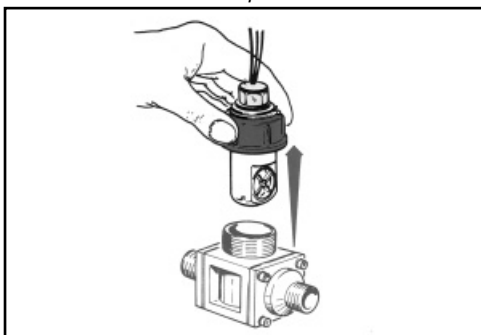

Remove the Rapid Check unit.

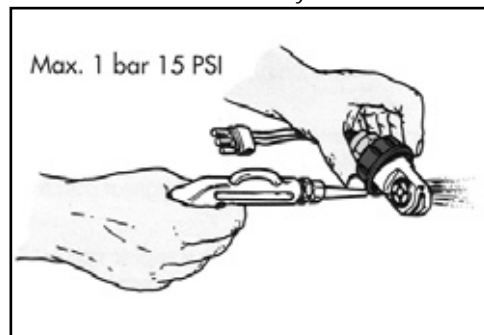

Use compressed air to check that the turbine unit rotates freely.

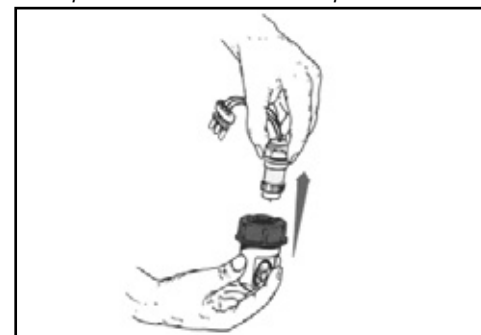

Separate the sensor from the Rapid Check unit.

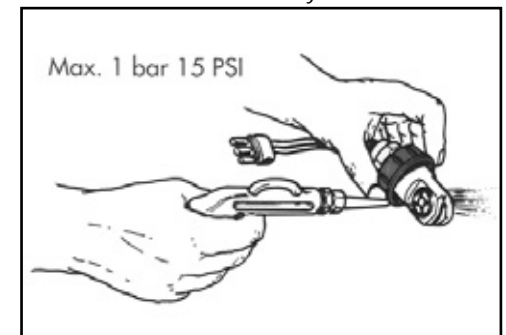

Use compressed air to check that the turbine unit rotates freely.

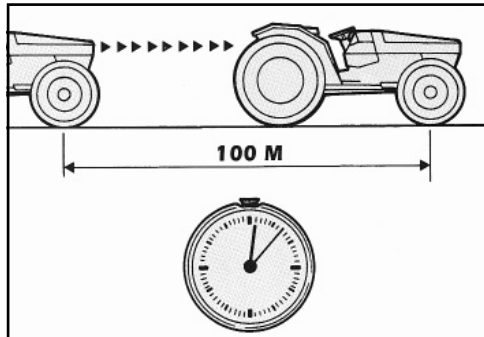

Determine actual speed of travel.

Step 2 Determining the Actual Speed Of Travel

Your Pegasus has been factory set with a calibration number. This should be fine-tuned prior to commencement of spraying and checked by your dealer. This is done by traveling a known distance (usually 100 metres) and comparing the distance measured by the Spray Controller to the known distance. If there is a discrepancy, the Spray Controller Manual explains how to easily adjust the calibration number automatically.

For the MT3405 Spray Controller, refer to page 2.23 of the Spray Controller manual.

For the MT9000 Spray Controller, refer to page 2.23 of the Spray Controller manual.

For the Teejet 854 Spray Controller, refer to page 2.23 of the Spray Controller manual.

Step 3 Measure Swath Width

The spray controller requires the boom width to be entered in 3/4/5/6 parts.

Measure the nozzle spacing and multiply nozzle spacing by the number of nozzles on each boom section to establish the width of each boom section.

$$\begin{aligned} \text{eg, } & 0.5\text{m} \times 12 = 6\text{m} \\ & 0.5\text{m} \times 12 = 6\text{m} \\ & 0.5\text{m} \times 12 = 6\text{m} \end{aligned}$$



Buyers Guide - courtesy of Teejet.

Step 4 Select Nozzle Type & Size

Select Nozzle Type & Size according to:

- Chemical recommendations.
- Application rate required.
- Pressure setting.
- Swath width.
- Chosen speed of travel. (Use actual speed of travel, refer to step 2)

Two methods of selecting nozzle output are:

- Use the charts on pages 4.9 to 4.11 or the manufacturer's nozzle chart
- Calculate Required Nozzle Flow Rate.



A1 nozzle - courtesy of Teejet.

a) Use Your Manual's Chart Or Manufacturer's Nozzle Chart.

Using the chart on pages 4.9 to 4.11 or the manufacturer's nozzle rate chart, reference:

- Application rate (eg 50 l/ha),
- Speed of travel (eg 12km/hr), &
- Pressure setting (eg 250kPa), find the nearest nozzle to suit your requirements.

Also check to see what speed variations are available for applying the same rate. See pages 4.9 to 4.11.

It is usually best to select mid range pressure as this will allow the spray controller to adjust pressure up or down when speed variations occur.

NOTE

Boom sections may vary on some booms.

NOTE

Use your own experience or a registered rate calibration consultant to determine effective application rates in litres per hectare.

Nozzle	Remixes				Purgers				Nozzles			
	But	Pre	Post	Systemic	Contact	Systemic	Contact	Systemic	Contact	Systemic	Contact	Systemic
XR Tejet	(2-4 bar)	GOOD	GOOD	EXCELLENT	GOOD	EXCELLENT	GOOD	EXCELLENT	GOOD	EXCELLENT	GOOD	EXCELLENT
	(1-2 bar)	GOOD	GOOD	EXCELLENT	VERY GOOD	EXCELLENT	VERY GOOD	EXCELLENT	VERY GOOD	EXCELLENT	VERY GOOD	EXCELLENT
XRC Tejet	(2-4 bar)	GOOD	GOOD	EXCELLENT	GOOD	EXCELLENT	GOOD	EXCELLENT	GOOD	EXCELLENT	GOOD	EXCELLENT
	(1-2 bar)	GOOD	GOOD	EXCELLENT	VERY GOOD	EXCELLENT	VERY GOOD	EXCELLENT	VERY GOOD	EXCELLENT	VERY GOOD	EXCELLENT
Turbo Tejet	(2-4 bar)	GOOD	GOOD	EXCELLENT	GOOD	EXCELLENT	GOOD	EXCELLENT	GOOD	EXCELLENT	GOOD	EXCELLENT
	(1-2 bar)	GOOD	GOOD	EXCELLENT	VERY GOOD	EXCELLENT	VERY GOOD	EXCELLENT	VERY GOOD	EXCELLENT	VERY GOOD	EXCELLENT
AI Tejet	(2-4 bar)	VERY GOOD	VERY GOOD	EXCELLENT	EXCELLENT	EXCELLENT	EXCELLENT	EXCELLENT	EXCELLENT	EXCELLENT	EXCELLENT	EXCELLENT
	(1-2 bar)	VERY GOOD	VERY GOOD	EXCELLENT	VERY GOOD	EXCELLENT	VERY GOOD	EXCELLENT	VERY GOOD	EXCELLENT	VERY GOOD	EXCELLENT
AIC Tejet	(2-4 bar)	VERY GOOD	VERY GOOD	EXCELLENT	EXCELLENT	EXCELLENT	EXCELLENT	EXCELLENT	EXCELLENT	EXCELLENT	EXCELLENT	EXCELLENT
	(1-2 bar)	VERY GOOD	VERY GOOD	EXCELLENT	VERY GOOD	EXCELLENT	VERY GOOD	EXCELLENT	VERY GOOD	EXCELLENT	VERY GOOD	EXCELLENT
DC Tejet	(2-4 bar)	VERY GOOD	VERY GOOD	EXCELLENT	EXCELLENT	EXCELLENT	EXCELLENT	EXCELLENT	EXCELLENT	EXCELLENT	EXCELLENT	EXCELLENT
	(1-2 bar)	VERY GOOD	VERY GOOD	EXCELLENT	VERY GOOD	EXCELLENT	VERY GOOD	EXCELLENT	VERY GOOD	EXCELLENT	VERY GOOD	EXCELLENT
Twinjet	(2-4 bar)	EXCELLENT	EXCELLENT	EXCELLENT	EXCELLENT	EXCELLENT	EXCELLENT	EXCELLENT	EXCELLENT	EXCELLENT	EXCELLENT	EXCELLENT
	(1-2 bar)	EXCELLENT	EXCELLENT	EXCELLENT	EXCELLENT	EXCELLENT	EXCELLENT	EXCELLENT	EXCELLENT	EXCELLENT	EXCELLENT	EXCELLENT
Turbo Floodjet	(2-4 bar)	EXCELLENT	EXCELLENT	EXCELLENT	EXCELLENT	EXCELLENT	EXCELLENT	EXCELLENT	EXCELLENT	EXCELLENT	EXCELLENT	EXCELLENT
	(1-2 bar)	EXCELLENT	EXCELLENT	EXCELLENT	EXCELLENT	EXCELLENT	EXCELLENT	EXCELLENT	EXCELLENT	EXCELLENT	EXCELLENT	EXCELLENT
Turjet	(2-4 bar)	EXCELLENT	EXCELLENT	EXCELLENT	EXCELLENT	EXCELLENT	EXCELLENT	EXCELLENT	EXCELLENT	EXCELLENT	EXCELLENT	EXCELLENT
	(1-2 bar)	EXCELLENT	EXCELLENT	EXCELLENT	EXCELLENT	EXCELLENT	EXCELLENT	EXCELLENT	EXCELLENT	EXCELLENT	EXCELLENT	EXCELLENT
AI Tejet even	(2-4 bar)	EXCELLENT	EXCELLENT	EXCELLENT	EXCELLENT	EXCELLENT	EXCELLENT	EXCELLENT	EXCELLENT	EXCELLENT	EXCELLENT	EXCELLENT
	(1-2 bar)	EXCELLENT	EXCELLENT	EXCELLENT	EXCELLENT	EXCELLENT	EXCELLENT	EXCELLENT	EXCELLENT	EXCELLENT	EXCELLENT	EXCELLENT
Tejet even	(2-4 bar)	EXCELLENT	EXCELLENT	EXCELLENT	EXCELLENT	EXCELLENT	EXCELLENT	EXCELLENT	EXCELLENT	EXCELLENT	EXCELLENT	EXCELLENT
	(1-2 bar)	EXCELLENT	EXCELLENT	EXCELLENT	EXCELLENT	EXCELLENT	EXCELLENT	EXCELLENT	EXCELLENT	EXCELLENT	EXCELLENT	EXCELLENT
Twinjet even	(2-4 bar)	EXCELLENT	EXCELLENT	EXCELLENT	EXCELLENT	EXCELLENT	EXCELLENT	EXCELLENT	EXCELLENT	EXCELLENT	EXCELLENT	EXCELLENT
	(1-2 bar)	EXCELLENT	EXCELLENT	EXCELLENT	EXCELLENT	EXCELLENT	EXCELLENT	EXCELLENT	EXCELLENT	EXCELLENT	EXCELLENT	EXCELLENT
Conjet	(2-4 bar)	EXCELLENT	EXCELLENT	EXCELLENT	EXCELLENT	EXCELLENT	EXCELLENT	EXCELLENT	EXCELLENT	EXCELLENT	EXCELLENT	EXCELLENT
	(1-2 bar)	EXCELLENT	EXCELLENT	EXCELLENT	EXCELLENT	EXCELLENT	EXCELLENT	EXCELLENT	EXCELLENT	EXCELLENT	EXCELLENT	EXCELLENT
Disc-Core	(2-4 bar)	EXCELLENT	EXCELLENT	EXCELLENT	EXCELLENT	EXCELLENT	EXCELLENT	EXCELLENT	EXCELLENT	EXCELLENT	EXCELLENT	EXCELLENT
	(1-2 bar)	EXCELLENT	EXCELLENT	EXCELLENT	EXCELLENT	EXCELLENT	EXCELLENT	EXCELLENT	EXCELLENT	EXCELLENT	EXCELLENT	EXCELLENT

Nozzle selection chart - courtesy of Teejet.

b) Calculate Required Nozzle Flow Rate

If you know:

- the application rate required (eg 50 l/ha),
- speed of travel (eg 12km/hr),
- swath width (eg 18m), &
- the number of nozzles on the boom (eg 36).

The following formula can be used to establish required flow rate per nozzle:

$$\text{Nozzle Flow Rate (l/min)} = \frac{\text{Speed (km/hr)} \times \text{Swath Width (m)} \times \text{Application Rate (l/ha)} \div 600}{\text{Number of nozzles}}$$

eg, $[(12 \times 18 \times 50) \div 600] \div 36 = 0.5 \text{ l/min}$ for each nozzle

Nozzle	bar	l/min	l/ha Δ 50 cm							
			4 km/h	5 km/h	6 km/h	7 km/h	8 km/h	10 km/h	12 km/h	
XR001 XR1001 (100 mesh)	1.0	0.23	69.0	55.2	46.0	39.4	34.5	27.6	23.0	
	1.5	0.28	84.0	67.2	56.0	48.0	42.0	33.6	28.0	
	2.0	0.32	96.0	76.8	64.0	54.9	48.0	38.4	32.0	
XR0015 XR1001 (100 mesh)	1.0	0.42	108	86.4	70.4	58.3	51.0	40.8	34.0	
	1.5	0.48	144	115.2	96.0	80.3	70.4	54.4	45.0	
	2.0	0.59	177	141.6	115.2	96.0	83.3	64.8	54.0	
XR002 XR1002 (50 mesh)	1.0	0.46	136	108.8	89.6	75.2	65.9	51.9	43.0	
	1.5	0.56	174	139.2	115.2	96.0	84.0	67.2	56.0	
	2.0	0.65	216	172.8	144.0	120.0	105.6	83.5	69.0	

l/min column on nozzle chart - courtesy of Teejet.

An alternative formula is:

$$\text{Nozzle Flow Rate (l/min)} = \frac{\text{Speed (km)} \times \text{Nozzle Spacing (cm)} \times \text{Application Rate (l/ha)} \div 60,000}{\text{Number of nozzles}}$$

eg, $[(12 \times 50 \times 50) \div 60,000] = 0.5 \text{ l/min}$

Now using the nozzle chart look down the nozzle capacity column (l/min) and select a nozzle to suit the output (eg 0.5 l/min). Refer to pages 4.9 to 4.11 for nozzle charts.

NOTE

Always use Actual Speed of Travel for speed in the above formula.

Step 5 Fit the Selected Nozzles to the Boom

Fit the selected nozzles to the boom as per the nozzle manufacturers specifications.

NOTE

Remember when selecting nozzle outputs that higher pressures and wider spray angles usually give finer droplet sizes than lower pressures and narrower spray angles.



Test the actual output of the nozzles.

Step 6 (Recommended) Check Nozzle Accuracy & Determine Nozzle Output

Test the actual output of the nozzles using the following procedure:

- Ensure there is adequate water in the tank.
 - IMPORTANT:** Do not use mixed pesticides for testing.
- Start the sprayer and set the spray Controller master switch into MANUAL position and adjust the operating pressure (PTO to continue instructions).

WARNING

Do not use mixed pesticides for testing. Use only clean water. Use of pesticides when testing is hazardous to your health.

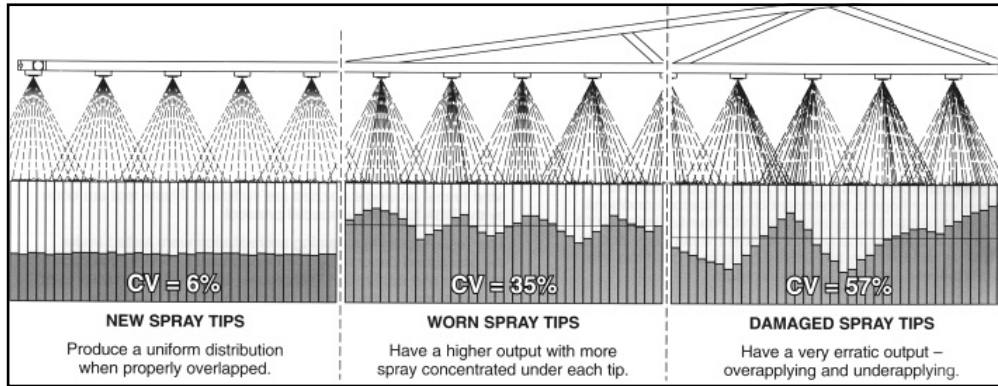

Spray tip wear - courtesy of Teejet.

- c) Collect and measure the volume of spray from one nozzle and adjust pressure so that the nozzle gives the specified output (eg 0.5 l/min).

IMPORTANT:

Do not use a worn nozzle to set the pressure setting and nozzle rates.

If the boom is not fitted with new nozzles, fit one new nozzle and use it to set the flow rate and pressure setting.

This sets the standard flow rate, pressure setting and spray pattern with which to test the performance of other nozzles.

- d) When the pressure is set to give a specified nozzle output (using a new nozzle), collect and measure the volume of spray from each nozzle for one minute in a collection jar or calibrating jug.

Specially designed nozzle testing equipment such as nozzle calibrating jugs can be used to simplify nozzle calibration.

- e) Visually check nozzle spray patterns and spray angle for accuracy and, if necessary, replace any faulty nozzles.

- f) Discard and replace any nozzle that deviates more than 10% from the specified output (eg with a 0.5 l/min specification- discard any nozzles 0.45 l/min and under or 0.55 l/min and over).
- g) Check replacement nozzles by collecting and measuring output from each replacement.
- h) Record the output of each nozzle on the boom. Add the outputs together and divide by the number of nozzles to get the required output of each nozzles in one minute.
- eg, Total spray output 18 l/min ÷ 36 nozzles = 0.5 l/min per nozzle.

Step 7 Calculate Application Rate

When operating the spray controller, the controller automatically calculates and shows the rate of application.

$$\text{Application Rate (l/ha)} = \frac{\text{Spray Output (l/min)} \times 600}{\text{Speed (km/hr)} \times \text{Swath Width (m)}}$$

eg, $[18 \times 600] \div [12 \times 18]$
 = 50 l/ha

CAUTION

Do not use a worn nozzles to set the pressure setting and nozzle rates, otherwise inaccurate calibration will occur.



+/- keys.

Step 8

If tested application is not satisfactory:

a) In **Auto mode** - if application rate is not being achieved:

- i) Operating pressure will climb if nozzles are too small or blocked or speed is too slow.

Likewise, if your pressure filter is blocked (even partially), you may experience excessive pressure at the pump.

Make adjustments accordingly.

- ii) Operating pressure will fall if nozzles are too large or speed is too slow. Make adjustments accordingly.

b) In **Manual mode** - the Controller application rate can be altered by:

- i) Adjusting pressure up or down to increase or decrease rate of application (use +/- keys).
- ii) Adjusting spraying speed up or down to decrease or increase rate of application.
- iii) Changing to a different nozzle capacity.

Repeat necessary testing procedures and calculation of application rate if adjustments or changes are made.

NOTE

Full instructions of controller operation are contained in your separate Controller Manual.

NOTE

All nozzles have a pressure and flow rate range to achieve the best results.
Ensure you have selected the nozzle which best suits your application to avoid any problems.

Step 9

Add The Correct Amount Of Chemical To The Tank

a) For **land area rates** (litres or kg per hectare), use the following formula:

Chemical Required (litres) =

Tank Volume (litres) x Recommended Chemical Rate (l/ha) ÷ Spray Application Rate (l/ha)

eg, $[2000 \times 2.0] \div 50$
= 80 litres

b) If **chemical recommendation is given in water volume rates** use the following formula:

Chemical Required (litres) =

Tank Volume (litres) x Recommended Chemical Rate (l/100 litres) ÷ 100

eg, $[2000 \times 4] \div 100$
= 80 litres

c) For **land area covered**, use the formula:

Area Covered (ha) =

Tank Volume (litres) ÷ Spray Application Rate (l/ha)

eg, $2000 \div 50$
= 40 hectares

d) For **tank volume required**, use the formula:

Tank Volume Required (litres) =

Area (ha) x Spray Application Rate (l/ha)

eg, 20×50
= 1000 litres

NOTE

Mix only the amount required. Avoid wastage and the problem of needless chemical disposal.

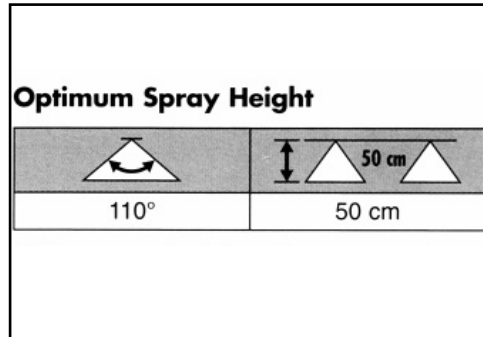

Boom height - courtesy of Teejet.

Step 10 Adjust Boom Height

Boom height should be adjusted to suit the type of nozzle used, terrain and crop or soil being sprayed.

Minimum boom height recommendations depend on the nozzle spray angle and nozzle spacing.

Refer to Nozzle chart recommendations.

Step 11 Record All Data For Future Reference

Record all your calibration data on the work sheets given at the end of this section.

Photocopy the work sheets to obtain the number of work sheets required.

Section 4

[XR = Extended Range]
 [AI = Air Induction]

XR & AI TeeJet Nozzle Chart

Nozzle (filter)	Bar	l/min	Litres/ha @ 500mm nozzle spacing												
			4km/h	5km/h	6km/h	7km/h	8km/h	10km/h	12km/h	16km/h	18km/h	20km/h	25km/h	30km/h	35km/h
XR11001 AI11001 (100 mesh)	1.0	0.23	69.0	55.2	46.0	39.4	34.5	27.6	23.0	17.3	15.3	13.8	11.0	9.2	7.9
	1.5	0.28	84.0	67.2	56.0	48.0	42.0	33.6	28.0	21.0	18.7	16.8	13.4	11.2	9.6
	2.0	0.32	96.0	76.8	64.0	54.9	48.0	38.4	32.0	24.0	21.3	19.2	15.4	12.8	11.0
	3.0	0.39	117	93.6	78.0	66.9	58.5	46.8	39.0	29.3	26.0	23.4	18.7	15.6	13.4
	4.0	0.45	135	108	90.0	77.1	67.5	54.0	45.0	33.8	30.0	27.0	21.6	18.0	15.4
XR110015 AI110015 (100 mesh)	1.0	0.34	102	81.6	68.0	48.3	51.0	40.8	34.0	25.5	22.7	20.4	16.3	13.6	11.7
	1.5	0.42	126	101	84.0	72.0	63.0	50.4	42.0	31.5	28.0	25.2	20.2	16.8	14.4
	2.0	0.48	144	115	96.0	82.3	72.0	57.6	48.0	36.0	32.0	28.8	23.0	19.2	16.5
	3.0	0.59	177	142	118	101	88.5	70.8	59.0	44.3	39.3	35.4	28.3	23.6	20.2
	4.0	0.68	204	163	136	117	102	81.6	68.0	51.0	45.3	40.8	32.6	27.2	23.3
XR11002 AI11002 (50 mesh)	1.0	0.46	138	110	92.0	78.9	69.0	55.2	46.0	34.5	30.7	27.6	22.1	18.4	15.8
	1.5	0.56	168	134	112	96.0	84.0	67.2	56.0	42.0	37.3	33.6	26.9	22.4	19.2
	2.0	0.65	195	156	130	111	97.5	78.0	65.0	48.8	43.3	29.0	31.2	26.0	22.3
	3.0	0.79	237	190	158	135	119	94.8	79.0	59.3	52.7	47.4	37.9	31.6	27.1
	4.0	0.91	273	218	182	156	137	109	91.0	68.3	60.7	54.6	43.7	36.4	31.2
XR11003 AI11003 (50 mesh)	1.0	0.68	204	163	136	117	102	81.6	68.0	51.0	45.3	40.8	32.6	27.2	23.3
	1.5	0.83	249	199	166	142	125	100	83.0	62.3	55.3	49.8	39.8	33.2	28.5
	2.0	0.96	288	230	192	165	144	115	96.0	72.0	64.0	57.6	46.1	38.4	32.9
	3.0	1.18	354	283	236	202	177	142	118	88.5	78.7	70.8	56.6	47.2	40.5
	4.0	1.36	408	326	272	233	204	163	136	102	90.7	81.6	65.3	54.4	46.6
XR11004 AI11004 (50 mesh)	1.0	0.91	273	218	182	156	137	109	91.0	68.3	60.7	54.6	43.7	36.4	31.2
	1.5	1.12	336	269	224	192	168	134	112	84.0	74.7	67.2	53.8	44.8	38.4
	2.0	1.29	387	310	258	221	194	155	129	96.8	86.0	77.4	61.9	51.6	44.2
	3.0	1.58	474	379	316	271	237	190	158	119	105	94.8	75.8	63.2	54.2
	4.0	1.82	546	437	364	312	273	218	182	137	121	109	87.4	72.8	62.4
XR11005 AI11005 (50 mesh)	1.0	1.14	342	274	228	195	171	137	114	85.5	76.0	68.4	54.7	45.6	39.1
	1.5	1.39	417	334	278	238	209	167	139	104	92.7	83.4	66.7	55.6	47.7
	2.0	1.61	483	386	322	276	242	193	161	121	107	96.6	77.3	64.4	55.2
	3.0	1.97	591	473	394	338	296	236	197	148	131	118	94.6	78.8	67.5
	4.0	2.27	681	545	454	389	341	272	227	170	151	136	109	90.8	77.8

Nozzle	Bar	l/min	Litres/ha @ 500mm nozzle spacing											
			5km/h	6km/h	7km/h	8km/h	10km/h	12km/h	16km/h	20km/h	25km/h	30km/h	35km/h	
TDAM015 TD015 (Green)	1	0,346	83	69	59	52	42	35	26	21				
	2	0,490	118	98	84	74	59	49	36	29				
	3	0,600	144	120	103	90	72	60	45	36				
	4	0,693	166	139	119	104	83	69	52	42				
	5	0,775	186	155	133	116	93	77	58	47				
	6	0,849	204	170	146	127	102	85	64	51				
	7	0,917	220	183	157	138	110	92	69	55				
	8	0,980	235	196	168	147	118	98	74	59				
	9	1,039	249	208	178	156	125	104	78	63				
	10	1,095	263	219	188	164	132	109	82	66				
TDAM02 TD02 (Yellow)	1	0,462	111	92	79	69	55	46	35	28				
	2	0,653	157	131	112	98	78	65	49	39				
	3	0,800	192	160	137	120	96	80	60	48				
	4	0,924	222	185	159	139	111	92	69	56				
	5	1,033	248	207	177	155	124	103	77	62				
	6	1,131	271	226	194	170	136	113	85	68				
	7	1,222	293	244	209	183	147	122	92	73				
	8	1,306	313	261	224	196	157	131	98	78				
	9	1,386	332	277	237	208	166	139	104	83				
	10	1,460	350	292	250	219	175	146	110	88				
TDAM025 TD025 (Lilac)	1	0,577	138	115	99	87	69	58	43	35				
	2	0,816	196	163	140	122	98	82	61	49				
	3	1,000	240	200	171	150	120	100	75	60				
	4	1,154	278	231	199	174	139	115	86	70				
	5	1,291	310	259	221	194	155	129	96	78				
	6	1,414	339	283	243	213	170	141	106	85				
	7	1,528	366	305	261	229	184	153	115	92				
	8	1,632	391	326	280	245	196	163	122	98				
	9	1,732	415	346	296	260	208	174	130	104				
	10	1,826	438	365	313	274	219	183	138	110				
TDAM03 TD03 (Blue)	1	0,693	166	139	119	104	83	69	52	42				
	2	0,980	234	196	168	147	118	98	74	59				
	3	1,200	288	240	206	180	144	120	90	72				
	4	1,385	333	278	238	208	166	138	104	84				
	5	1,549	372	310	266	232	186	154	116	94				
	6	1,697	408	340	292	254	204	170	128	102				
	7	1,833	440	366	314	276	220	184	138	110				
	8	1,960	460	392	336	294	236	196	148	118				
	9	2,078	498	416	356	312	250	208	156	126				
	10	2,191	526	438	376	328	264	218	164	132				

Nozzle	Bar	l/min	Litres/ha @ 500mm nozzle spacing											
			5km/h	6km/h	7km/h	8km/h	10km/h	12km/h	16km/h	20km/h	25km/h	30km/h	35km/h	
TDAM04 TD04 (Red)	1	0,924	222	185	158	139	111	92	69	55				
	2	1,306	313	261	224	196	157	131	98	78				
	3	1,600	384	320	274	240	192	160	120	96				
	4	1,847	444	370	318	278	222	184	138	112				
	5	2,066	496	414	354	310	248	206	154	124				
	6	2,263	542	452	388	340	272	226	170	136				
	7	2,444	586	488	418	366	294	244	184	146				
	8	2,612	626	522	448	392	314	260	196	156				
	9	2,771	664	554	474	416	332	278	208	166				
	10	2,921	700	584	500	438	350	292	220	176				
TDAM05 TD05 (Brown)	1	1,155	277	231	198	173	139	116	87	69				
	2	1,633	392	327	280	245	196	163	122	98				
	3	2,000	480	400	342	300	240	200	150	120				
	4	2,309	556	462	398	348	278	230	172	140				
	5	2,582	620	518	442	388	310	258	192	156				
	6	2,828	678	566	486	426	340	282	212	170				
	7	3,055	732	610	522	458	368	306	230	184				
	8	3,264	682	652	560	490	392	326	245	196				
	9	3,464	830	692	592	520	416	346	260	208				
	10	3,651	876	730	626	548	438	366	276	219				
TDAM06 TD06 (Grey)	1	1,386	333	277	238	208	166	139	104	83				
	2	1,960	470	392	336	294	235	196	147	118				
	3	2,400	576	480	412	360	288	240	180	144				
	4	2,771	666	556	476	416	332	276	208	168				
	5	3,098	744	620	532	464	372	308	232	188				
	6	3,394	816	680	584	508	408	340	256	204				
	7	3,666	880	732	628	552	440	368	276	220				
	8	3,919	940	784	672	588	475	392	296	236				
	9	4,157	996	832	712	624	500	416	312	252				
	10	4,382	1052	876	752	656	528	436	328	264				

Step 1 Check the Sprayer is in Good Working Order	
Step 2 Determine Actual Speed of Travel Follow Instructions on page 60 (Pegasus Calibration page).	
Tractor model	
Gear	
Range	
Dual power	
Engine RPM	
Speed in Km/h	
Step 3 Measure Boom Widths	
Boom section 1:	
Boom section 2:	
Boom section 3:	
Boom section 4:	
Boom section 5:	
Boom section 6:	
Boom section 7:	
Step 4 Select Nozzle Type & Size	
<ul style="list-style-type: none"> • Chemical: • Type of Nozzle: • Pressure Setting: • Travel speed (km/hr): • Total number of nozzles to be used 	

Nozzle Flow Rate (l/min) = $\text{Speed (km/hr)} \times \text{Swath Width (m)} \times \text{Application Rate (l/ha)} \div 600 \div \text{Number of nozzles}$ x x ÷ 600 ÷ = l/min for each nozzle
Step 5 Fit Selected Nozzles to Boom
Nozzle Type:
Nozzle Size:
Nozzle Colour:
Step 6 Check Nozzle Accuracy & Determine Nozzle Output
Thoroughly check nozzles & test the actual output of each nozzle.
<ul style="list-style-type: none"> • Pressure Setting: • Individual Nozzle Outputs: • Sum of Nozzle Outputs:
Step 7 Calculate Application Rate
The spray Controller automatically calculates and shows the rate of application.
Application Rate (l/ha) = $\text{Spray Output (l/min)} \times 600 \div \text{Speed (km/hr)} \times \text{Swath Width (m)}$ [..... x 600] ÷ [..... x] =

Step 8 If Tested Application is Not Satisfactory - Make Changes & Repeat Procedure	
.....	
.....	
Step 9 Add Correct Amount of Chemical	
<ul style="list-style-type: none"> • Chemical: • Water Quantity: • Chemical Added: 	
Step 10 Boom Height	
.....	
Step 11	
Record Data	
Date	
Farm location	
Crop to be sprayed	
Spray Volume litres/ha	
Nozzle type	
Nozzle size & colour	
No. of nozzles used	
Nozzle pressure	
Tested Output in l/min	
Actual Litres/Hectare	

Step 1 Check the Sprayer is in Good Working Order	
Step 2 Determine Actual Speed of Travel Follow Instructions on page 60 (Pegasus Calibration page).	
Tractor model	
Gear	
Range	
Dual power	
Engine RPM	
Speed in Km/h	
Step 3 Measure Boom Widths	
Boom section 1:	
Boom section 2:	
Boom section 3:	
Boom section 4:	
Boom section 5:	
Boom section 6:	
Boom section 7:	
Step 4 Select Nozzle Type & Size	
<ul style="list-style-type: none"> • Chemical: • Type of Nozzle: • Pressure Setting: • Travel speed (km/hr): • Total number of nozzles to be used 	

Nozzle Flow Rate (l/min) = Speed (km/hr) x Swath Width (m) x Application Rate (l/ha) ÷ 600 ÷ Number of nozzles x x ÷ 600 ÷ = l/min for each nozzle
Step 5 Fit Selected Nozzles to Boom
Nozzle Type: Nozzle Size: Nozzle Colour:
Step 6 Check Nozzle Accuracy & Determine Nozzle Output
Thoroughly check nozzles & test the actual output of each nozzle. <ul style="list-style-type: none"> • Pressure Setting: • Individual Nozzle Outputs: • Sum of Nozzle Outputs:
Step 7 Calculate Application Rate
The spray Controller automatically calculates and shows the rate of application. Application Rate (l/ha) = Spray Output (l/min) x 600 ÷ Speed (km/hr) x Swath Width (m) [..... x 600] ÷ [..... x] =

Step 8 If Tested Application is Not Satisfactory - Make Changes & Repeat Procedure	
.....	
.....	
Step 9 Add Correct Amount of Chemical	
<ul style="list-style-type: none"> • Chemical: • Water Quantity: • Chemical Added: 	
Step 10 Boom Height	
.....	
Step 11	
Record Data	
Date	
Farm location	
Crop to be sprayed	
Spray Volume litres/ha	
Nozzle type	
Nozzle size & colour	
No. of nozzles used	
Nozzle pressure	
Tested Output in l/min	
Actual Litres/Hectare	

Step 1 Check the Sprayer is in Good Working Order	
Step 2 Determine Actual Speed of Travel Follow Instructions on page 60 (Pegasus Calibration page).	
Tractor model	
Gear	
Range	
Dual power	
Engine RPM	
Speed in Km/h	
Step 3 Measure Boom Widths	
Boom section 1:	
Boom section 2:	
Boom section 3:	
Boom section 4:	
Boom section 5:	
Boom section 6:	
Boom section 7:	
Step 4 Select Nozzle Type & Size	
<ul style="list-style-type: none"> • Chemical: • Type of Nozzle: • Pressure Setting: • Travel speed (km/hr): • Total number of nozzles to be used 	

Nozzle Flow Rate (l/min) = Speed (km/hr) x Swath Width (m) x Application Rate (l/ha) ÷ 600 ÷ Number of nozzles x x ÷ 600 ÷ = l/min for each nozzle
Step 5 Fit Selected Nozzles to Boom
Nozzle Type:
Nozzle Size:
Nozzle Colour:
Step 6 Check Nozzle Accuracy & Determine Nozzle Output
Thoroughly check nozzles & test the actual output of each nozzle.
<ul style="list-style-type: none"> • Pressure Setting: • Individual Nozzle Outputs: • Sum of Nozzle Outputs:
Step 7 Calculate Application Rate
The spray Controller automatically calculates and shows the rate of application.
Application Rate (l/ha) = Spray Output (l/min) x 600 ÷ Speed (km/hr) x Swath Width (m) [..... x 600] ÷ [..... x] =

Step 8 If Tested Application is Not Satisfactory - Make Changes & Repeat Procedure	
.....	
.....	
Step 9 Add Correct Amount of Chemical	
<ul style="list-style-type: none"> • Chemical: • Water Quantity: • Chemical Added: 	
Step 10 Boom Height	
.....	
Step 11	
Record Data	
Date	
Farm location	
Crop to be sprayed	
Spray Volume litres/ha	
Nozzle type	
Nozzle size & colour	
No. of nozzles used	
Nozzle pressure	
Tested Output in l/min	
Actual Litres/Hectare	

Greasing & Service Procedures	5.2
Grease Point Diagrams	5.3
Diaphragm Pumps	5.4
Filters	5.6
Diaphragms, Straps & Foam Markers	5.7
Motor Valves	5.8
Booms	5.9
Airbag Suspension	5.11

Greasing & Service Procedures

- 1 Clean suction line filter with each tank load.
- 2 Clean bottom-fill line filter after each tank fill if necessary.
- 3 Clean pressure line filter.
- 4 Check nozzle filters.
- 5 Check tyre pressure (350kPa), and check wheel nuts.
- 6 Check flush tank straps and tighten if necessary.
- 7 Clean Rapid-check flowmeter (refer to page 4.3).

- 8 Grease tractor to sprayer PTO universal joints every 8 hours.
Grease lightly until grease becomes firm in seals. Over greasing will break seals and allow dust and moisture to penetrate - increasing wear.
- 9 Grease PTO inner tubes every 8 hours.
To lubricate the inner tube, slide PTO shaft apart, clean the telescopic tubes, grease and reassemble.
- 10 Grease the PTO covers every 20 hours.

- 11 Check pump air chamber pressure on a regular basis. As a general guideline it should be 10%-20% of operating pressure (70-100 kPa [10-15 psi]). Refer to page 5.4 for more information.
- 12 To ensure trouble free spraying, flush the sprayer with fresh water thoroughly each day, and before changing chemicals.
Dispose of tank wash according to chemical manufacturers instructions.
- 13 Grease all boom joints, height adjuster points and other grease points (refer diagram on page 5.3).

Every 200 Hours or 6 Months - Whichever comes sooner

- 1 Lubricate quick release lock pins on PTO shaft.
- 2 Re-pack wheel bearings with grease.
- 3 Inspect air-axle (if fitted) and adjust if necessary.
- 4 Change air filter for foam marker.
- 5 Fully flush foam marker.
- 6 Grease all tank lid seals with vaseline.

NOTE

Ensure the sliding inner tubes of the PTO are greased every 8 hours (working around the clock equals 3 times/day), especially when doing a lot of tight turning

Chassis & PTO Grease Points

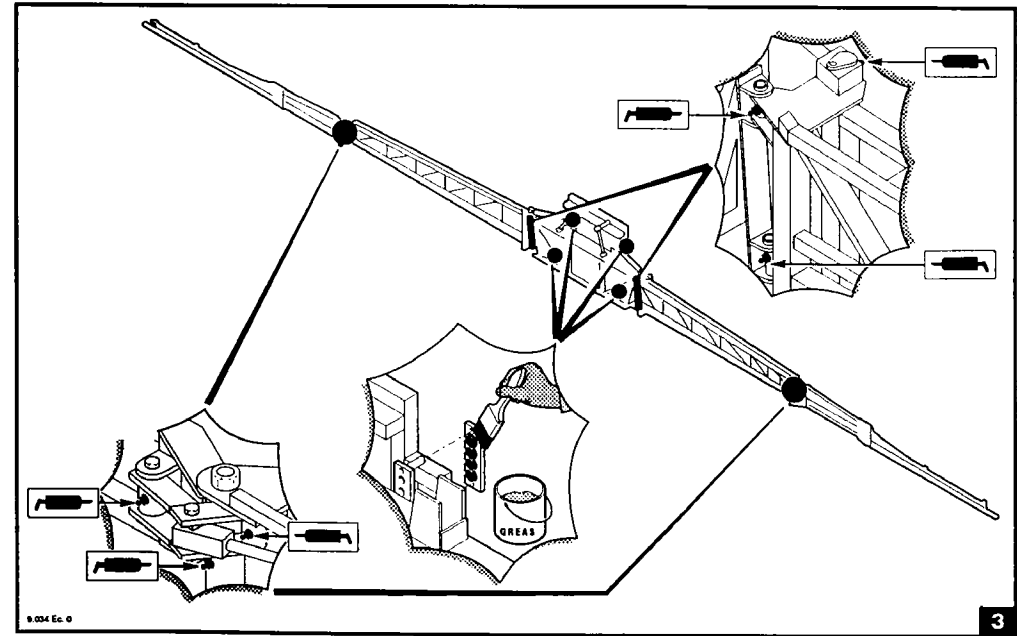
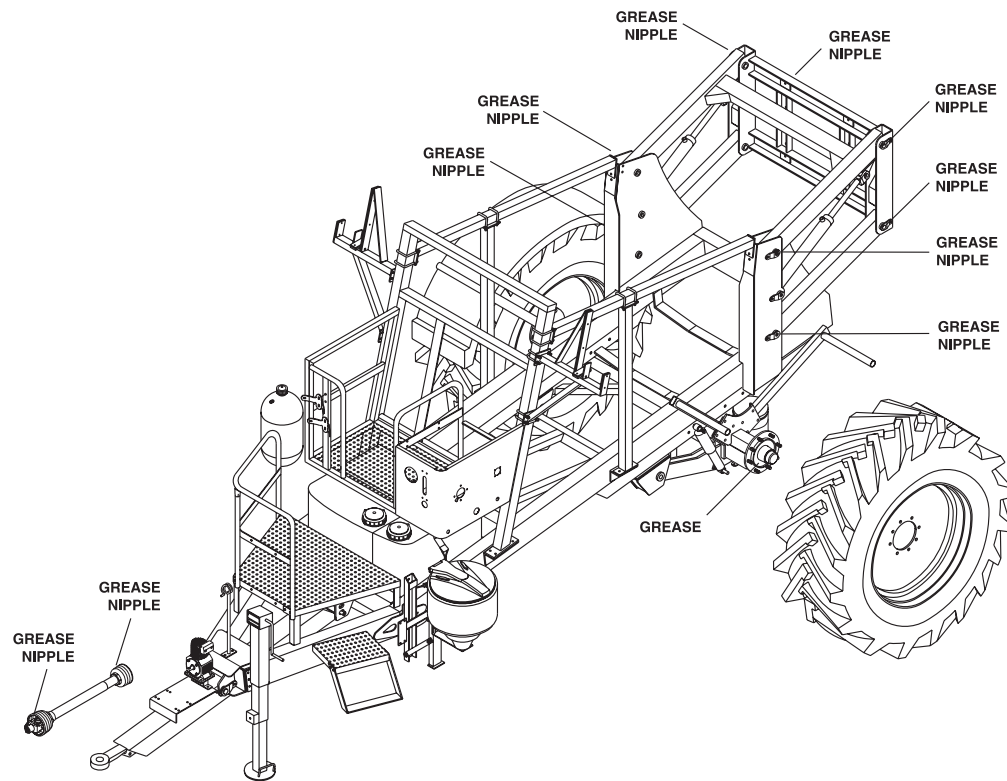

Boom Grease Points

Diaphragm Pump Maintenance

Annovi & Reverberi (A&R) pumps are of the piston-diaphragm type. All parts in contact with the spray liquid, which are subject to corrosion, are protected, making them ideal for spraying (herbicides, insecticides, fungicides, fertilisers, etc.), disinfection and washing.

Daily Before Starting the Pump

- 1 Check that oil is visible in sight glass (half way up) and top up if necessary with good clean motor oil 20W/30 or 20W/40.
- 2 Clean all sprayer filters. Blocked or semi blocked filters place extra stress on diaphragms.
- 3 Start with zero pressure and the pump will self prime immediately and clear air locks in suction line.

Daily after Use

- 1 Flush pump with clean water.
- 2 Drain filters and clean. A high percentage of pump failures are due to blocked filters.

Every 50 Hours

Check surge chamber pressure and adjust as follows:

- Air pressure 70-100kPa (10- 15psi) [Should be 10-20% of operating pressure].

Vibration of the delivery hose usually indicates that the air pressure in the surge chamber is incorrect.

The main cause of surge chamber diaphragm fracture is low pressure in this chamber.

Surge chamber pressure can be checked with an ordinary tyre gauge.

The above pressure range is a guide to the correct pressure.

However, if difficulties recur, adjust the pressure until an even flow is obtained from the pump (no pulsing of liquid at operating RPM). The pressure is best increased with a bicycle pump.

Every 250 hours or Every Season - Whichever Comes Sooner

- 1 Change oil and refill with 20W/30 oil.

Attention should be made to remove trapped air behind the diaphragms by rocking from side to side as instructed.

It is also good practise to run the pump for 10 minutes without pressure, and then, top up with oil before working the pump.

- 2 When changing the pump oil, check diaphragms and replace them if they are showing signs of wear.

This is normally a pre-season maintenance procedure which can be done easily as no special tools are required.

You can avoid unnecessary down time in spraying seasons by carrying out the proper maintenance.

- 3 Also check inlet and outlet valves and replace if worn. Worn valves not only reduce the output of the pump, but may reduce the life of the diaphragms.

CAUTION

Running a diaphragm pump faster than specified will not improve performance, but will damage and wear out moving parts.

Warranty will be made void by speeds in excess of those indicated on the pump name plate.

Excessive Diaphragm Failure

If you have excessive diaphragm failure check the following points. These will cause failure of diaphragms due to added stress or chemical attack.

- 1 **Most Important** - Pump not being flushed out daily with clean water after use.
- 2 Oil level too low allowing air between piston and diaphragm.
- 3 Air leaks in suction line.
- 4 Restricted suction line.
- 5 Restriction through suction filter.
- 6 Not cleaning suction filter regularly.
- 7 Worn suction and discharge valves.
- 8 Bypass line too small to carry full capacity of pump.
- 9 In cold climates - frozen suction/ discharge lines or water remaining in the pump after flushing.
- 10 Incorrect air setting or no air in air chamber.
- 11 Agitator excessively restricting bypass from pump.
- 12 Diaphragm material construction incorrect for chemical or solution being pumped.
- 13 Chemicals containing toluene or other aggressive solvents may require viton diaphragms - particularly if the pump is not properly flushed after use.

Pre-Season Servicing

For thorough pre-season servicing - check all aspects of the Pegasus and its operating components as outlined in the pre-delivery check list on page 1.7.

Pump Storage and Corrosion Protection

1 Warm Climates

If you operate in a warm climate with no chance of frost in the winter, you will not have any problems with frost damage.

If you are storing your sprayer between seasons, ensure your pump has been thoroughly flushed with clean water. A good idea is to run a mixture of 1% solution of summer mineral spraying oil through the pump and plumbing system. Summer spraying oil is water-soluble oil such as DC-Tron. This will coat and protect all internal pump parts. Ensure this mixture is flushed out before spraying commences in the new season.

2 Cold Climates

For prolonged storage, an anti-freeze mixture can be flushed through the pump. Ensure this is thoroughly flushed out prior to the commencement of spraying again.

If the pump is being stored overnight and a risk of freezing is imminent, drain all liquid from the pump and lines, including boom lines.



Remove outer screw & bowl of suction filter.



Remove & clean the filter element & components.



Reassemble & tighten outer screw of suction filter.



Regularly check and clean nozzle filters.

Filter Maintenance

Clean filters ensure that no solids enter the spraying system to block or damage pump or nozzles.

All filters should be cleaned regularly or after each spraying period.

Suction Filter

The suction filter should be cleaned regularly, or after each spray tank has been emptied.

See cleaning instructions on page 2.21.

Bottom-Fill Filter

The bottom-fill filter should be cleaned regularly, or after each spray tank has been filled.

See cleaning instructions on page 3.8.

Pressure Filters

The pressure filters should be cleaned regularly, or after each spray tank has been emptied.

See cleaning instructions on page 2.22.

Nozzle Filters

Nozzle filters should be cleaned regularly to avoid nozzle blockages.

See cleaning instructions on page 3.9.

If leaking occurs from the nozzle cap, check caps are correctly fitted with seals &/or the condition of the seals. Replace if necessary.

Foam Marker Filter

The foam marker filter should be cleaned regularly or after each tank of foam has been emptied.

See cleaning instructions on page 5.9.

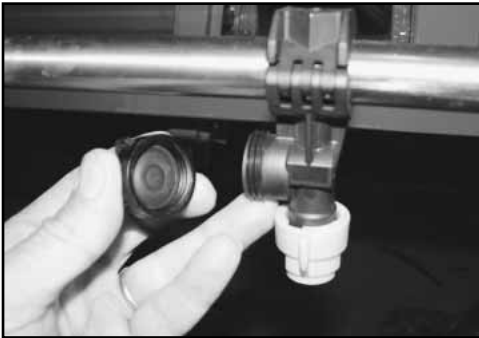

Remove & clean non-drip diaphragms regularly.

Non-Drip Diaphragms

Non-drip diaphragms should be cleaned regularly to prevent dripping from nozzles.

To clean the non-drip diaphragms:

- 1 Completely stop all sprayer functions.
- 2 Unscrew and remove the diaphragm cap.
- 3 Remove and clean any sediment Off the diaphragm membrane.
Replace the diaphragm membrane if damaged.
- 4 Refit the diaphragm.
- 5 Refit the diaphragm cap and carefully tighten.

NOTE

Do not over tighten the diaphragm cap. Over tightening the cap may impede flow through the diaphragm.



Regularly check that tank straps are tight.

Tank Straps

The tank straps of the flush tank should be kept tight so that the tank does not slide.

Tank clamps should be checked two or three times a day when the sprayer is new and the tank and frame are bedding-in.

Thereafter the tank clamps should be checked regularly.



Remove the Outback cabinet.

Foam Marker Maintenance

Air Pump Filter

The air pump filter should be inspected and cleaned weekly in normal operating conditions. More often in very dusty conditions. Otherwise, clean as often as experience dictates.

Foam Marker Cabinet

It's also a good idea to use an air hose to blow out the cabinet and air pump motor cavity after each 50 hours of operation. (Or more often in very dusty conditions.)

Tank

Keep dirt and debris out of the tank at all times.

The foam marker is protected by:

- A 50 mesh filter under the cabinet, &
- A 100 mesh filter located in the line before the liquid orifice.

These may need cleaning periodically, depending on cleanliness of operations.



Use an air hose clean out the cabinet area.

Off-Season Storage

To prepare the foam marker for storage, following these steps:

- 1 Drain the tank by removing the filter bowl.
- 2 Clean filter and replace filter bowl.
- 3 Add approximately 10 litres of weak foam solution mixture to the tank.
- 4 Using an air hose, blow the cabinet clean.
- 5 Clean the inlet air-filter (page 5.8).
- 6 Protect unplugged connectors from the weather.

NOTE

Do not drain the tank & plumbing for storage as it is better to store the unit wet rather than dry.

NOTE

If you experience freezing temperatures during the Off season, use an anti-freeze solution rather than a weak foam solution in the above steps.



Regularly clean the air filter.



Regularly clean the foam marker filter.

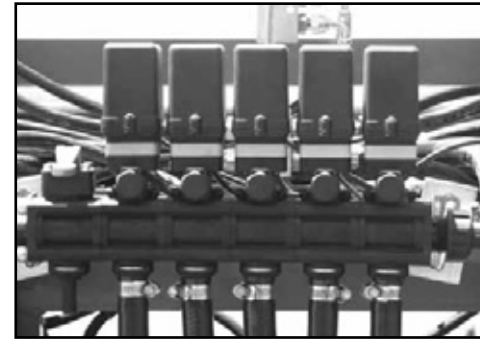

5-bank motor valves pictured.

Air Cleaner

The air cleaner, located on the frame as shown should be cleaned weekly. In extremely dusty conditions, it should be cleaned more frequently.

To clean the air filter:

- 1 Remove the wing nut on top of the air filter and remove the cover.
- 2 Remove the filter element and clean using warm water with a mild detergent.
- 3 Rinse thoroughly and dry.
- 4 Replace filter and cover.
- 5 Replace wing nut and tighten.

Liquid Filter

The liquid filter, located on the bottom of the foamer box, should be cleaned weekly. If water contains high amount of sediment and sand, it should be cleaned more frequently.

To clean the liquid filter:

- 1 Turn "off" the shut-off valve located beside the filter.
- 2 Remove the filter bowl - you should be able to unscrew by hand.
Be careful not to lose the gasket.
- 3 Remove the filter screen.
- 4 Wash the screen with clean water, if necessary a mild detergent can be used. Rinse thoroughly.
- 5 Replace screen in filter bowl.
- 6 Replace the filter bowl and tighten by hand.
- 7 Turn "On" the shut Off valve.

Electric Motor-Valve Maintenance

- 1 Flush system with clean water after each day's use, especially when using wettable powders.
- 2 Clean and drain the system for storage.
- 3 Do not apply lubricating oils or other petroleum products to the valves, as this may cause swelling of the rubber parts.

- 4 Check with the chemical manufacturer to be sure chemicals being used are compatible with the valve parts.
- 5 Check the ON/OFF operation of the valves periodically, especially if nozzles cannot be seen while operating.
- 6 Visually check electrical connections to ensure they are clean and secure.

CAUTION

Do not use compressed air when cleaning the air filter as it may damage the air filter element.

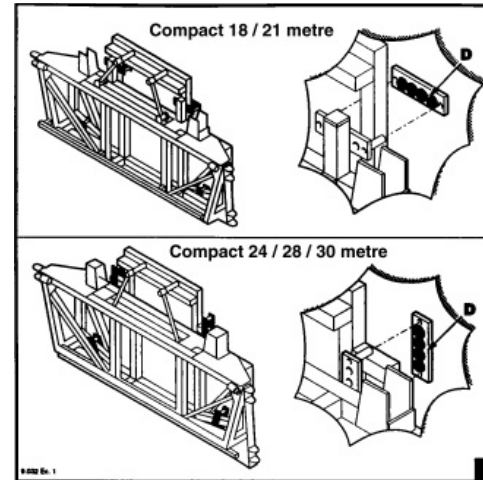
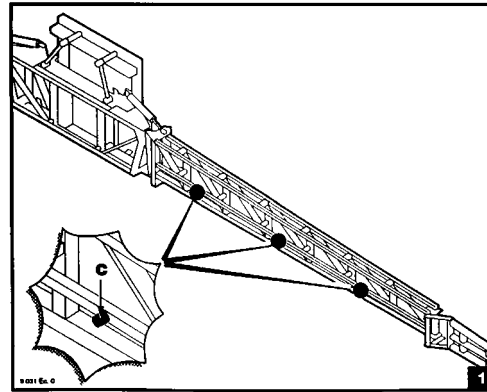

Boom Maintenance

Careful and regular maintenance will ensure good, long operational life.

Daily Maintenance

Clean the boom at the end of each working day or whenever the equipment is stopped for a period of time exceeding one hour. Rinse the plumbing lines and let clean water flow from the nozzles. Clean external surface with a water jet.

Ensure nozzles and nozzle bodies are correctly fixed and sealed when operating, also ensure non-drip mechanism are working.

Grease all grease-points as indicated on these pages.

Every 50 Hours Maintenance

Carry out the following maintenance procedures every 50 hours:

- 1 Make sure screws of all boom components are intact and tightened.
- 2 Retouch damage painted parts.
- 3 Check stop plugs (C), shown in figure 1 (above). Replace them if necessary.

- 4 Check wear of sliding shoes (D), shown in figure 2 (above).
- 5 Grease the boom, as shown in the illustration (below).

- 6 Grease the boom parallelogram lift & suspension pivot points.

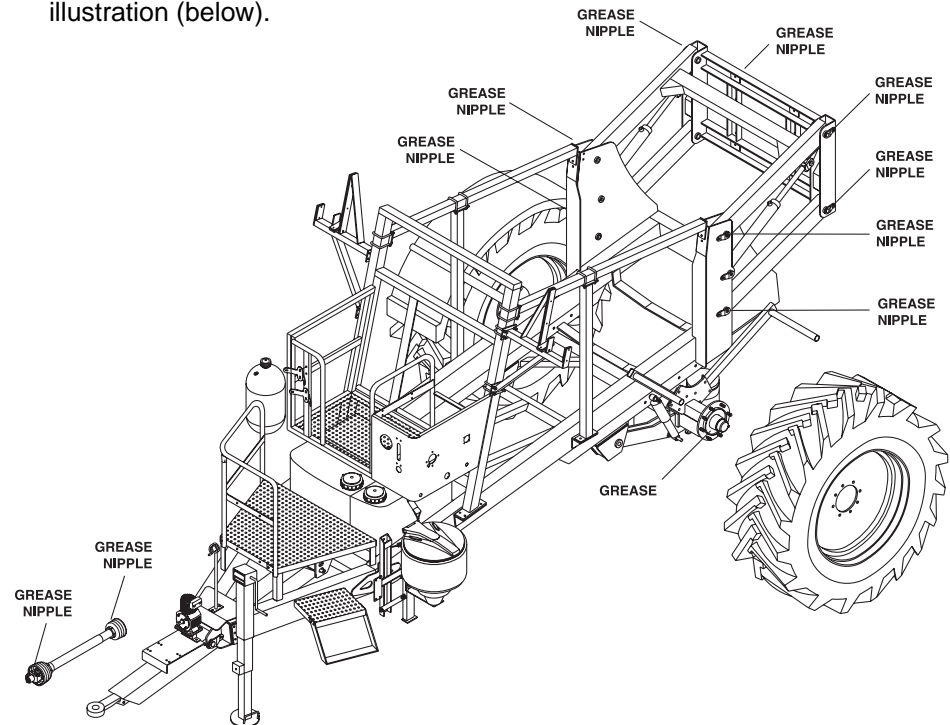

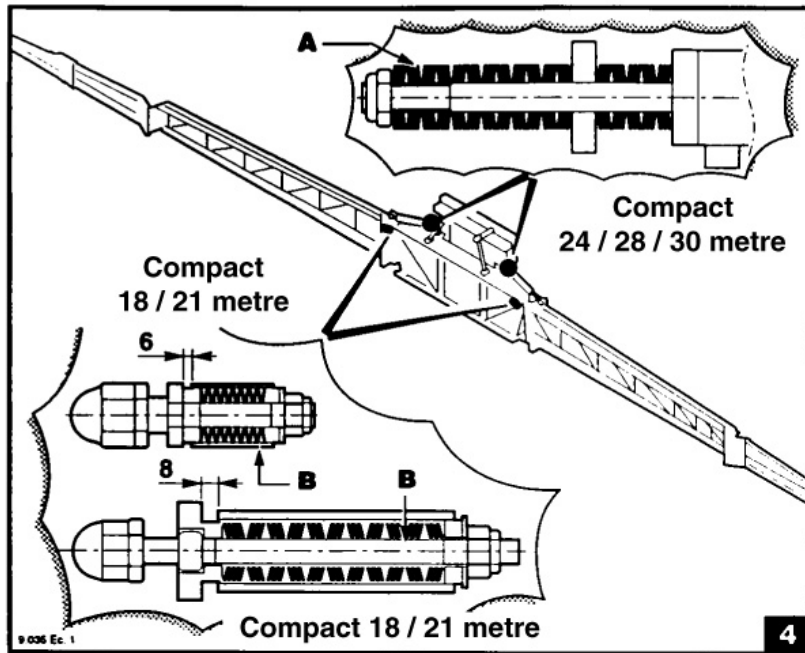

Periodical Maintenance

- 1 Check springs(A) [New SF only] and B) shown in figure 4 above; replace them if flattened or damaged.
- 2 Check springs (B) shown in figure 5 above; replace them if yielded.
- 3 Periodically check all hydraulic hoses and fittings for wear and replace if necessary.

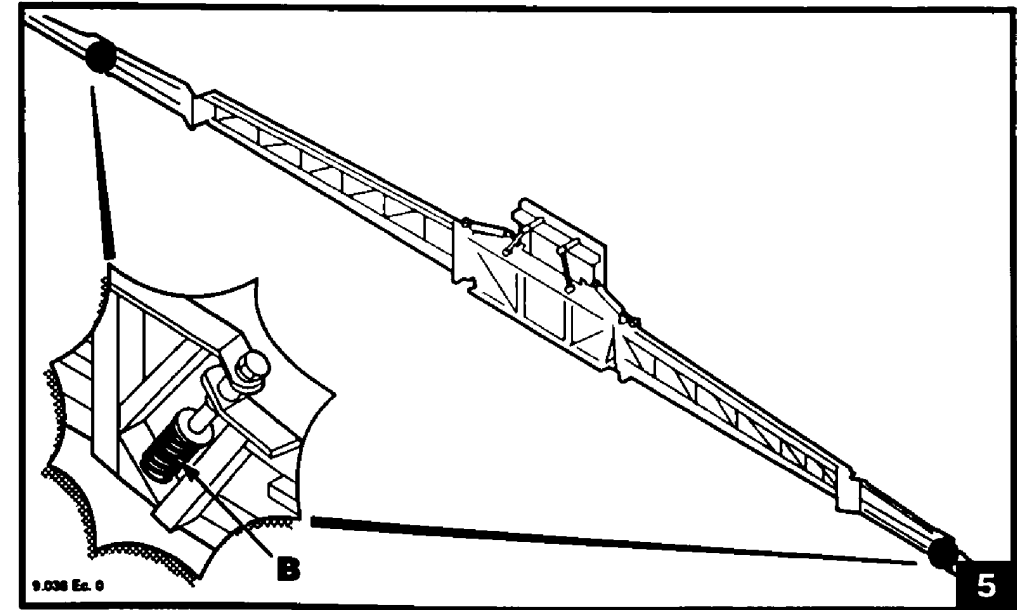

End of Season Maintenance

- 1 Before storage clean all equipment thoroughly.
- 2 If necessary protect sprayer plumbing components with anti-freeze fluid to avoid damage in severe temperatures.

NOTE

For boom alignment & adjustment refer to pages 3.12 to 3.16.

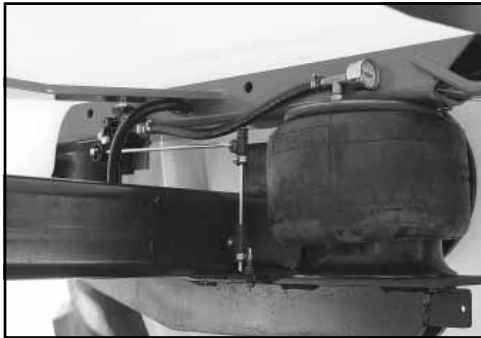

Airbag suspension system.

Trailing Arm Front Hinge

The bush of the Trailing Arm Front Hinge assembly can be replaced when worn.

To remove and replace the steel/rubber bush:

- 1 Remove the shock absorbers.
- 2 Disconnect the air level rods.
- 3 Undo and remove the 30mm bolt in each front hinge.
- 4 Remove and replace the rubber/steel bush of the front hinge.

A specially designed puller/pusher tool to move and replace the bush is available.

- 5 Re-assemble and replace the 30mm hinge bolts.

The 30mm nut must be **tightened** when the trailing arm is an approximate working position.

- 6 Re-connect the air level rods.
- 7 Refit the shock absorbers.



Air chamber drain valve/tap.

Air Chamber Drain Valve

The air chamber features a drain valve located at the bottom of the air reservoir.

The valve should be used regularly to remove any moisture from the chamber.

To remove moisture from the chamber:

- 1 Disengage the PTO/pump drive.
- 2 Open the drain valve until all moisture is removed.
- 3 Close the drain valve.
- 4 Engage the PTO/pump/compressor to recharge the chamber.



Air levelling valve with adjustable linkage.

Adjustable Linkage Assembly

To assemble the adjustable linkage of the air levelling valve:

- 1 Insert the 1/4" straight rod (A) into the rubber dampener link (B) and tighten the clamp (C).
- 2 Insert the lever arm (F - 1/4" rod with 90° bend) into the valve making sure the centre punch on the cam face (I) is pointing toward the vertical linkage.
- 3 Tighten the cap screw (G) to 5 ft/lbs.
- 4 Attach the rubber dampener (D) and clamp (E). Snug the clamp but do not tighten until installation is complete.

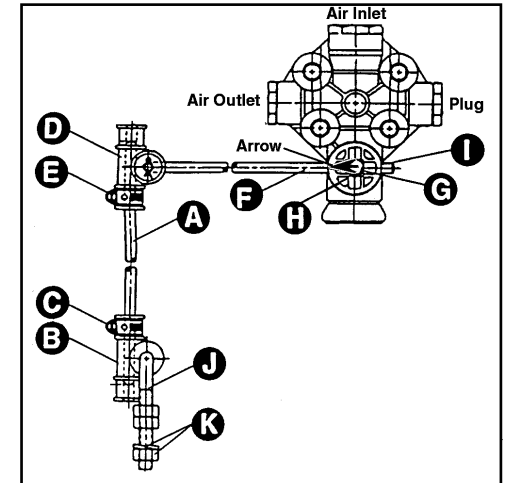

Linkage assembly illustration.

Note: To select the right or left hand position, hold the valve and rotate the lever (F) to the desired position.

The Pegasus airbag suspension uses a variable length lever arm. The recommended length is 7" to 13".

Tuning the valve to your suspension is done by increasing or decreasing to obtain optimum performance when the lever arm approaches 45° maximum up or down from a neutral horizontal position (see instructions on page 41).

Diaphragm Pump Problems	6.2
General Sprayer Problems	6.4
Hydraulic Pump Drive Problems	6.5
Foam Marker Problems	6.6
Airbag Suspension Problems	6.8
Boom Problems	6.9
Motor Valve Problems	6.10

PROBLEM	PROBABLE CAUSE	REMEDY
A Pump does not draw or deliver liquid. Pressure gauge fluctuates badly.	<ol style="list-style-type: none"> 1 One or more valves are not seating properly. 2 The pump is sucking in air through suction line. 3 Air has not been entirely evacuated from the pump. 4 Blocked suction filter. 5 Damaged or worn suction valves. 	<ol style="list-style-type: none"> 1 Clean valve seating. 2 Examine the suction hose and ensure it is firmly secured. 3 Rotate the pump with outlet hose and taps open. 4 Clean suction filter. 5 Replace suction valves.
B Liquid flow is irregular (Also check items under A)	<ol style="list-style-type: none"> 1 The air in the air chamber of the pump is incorrectly set. 2 Diaphragm split. 3 Damaged or worn valves. 4 Foreign matter holding valves open. 	<ol style="list-style-type: none"> 1 Check pressure in air chamber of pump. Set at 210-280Kpa (30-40 psi). 2 Replace diaphragm. 3 Replace valves. 4 Clean valves.
C Pump delivers insufficient pressure	<ol style="list-style-type: none"> 1 Regulating valve: <ul style="list-style-type: none"> • Sticking open • Not set for pressure. • Damaged or worn seat or spring. 2 Cylinder diaphragm ruptured. 3 Pump valves blocked, worn or damaged. 4 Spray nozzles worn, missing or exceed pump capacity. 	<ol style="list-style-type: none"> 1 Fix the regulator: <ul style="list-style-type: none"> • Unstick the valves. • Set the pressure. • Replace the spring. 2 Replace diaphragms. 3 Unblock valves and or replace. 4 Replace spray nozzles with appropriate size.
D Output drops & pump is noisy.	<ol style="list-style-type: none"> 1 Oil level is too low. 	<ol style="list-style-type: none"> 1 Top up with oil to correct level (1/2 way up the sump sight glass).

PROBLEM	PROBABLE CAUSE	REMEDY
E Oil being discharged through delivery line or discoloured oil in sight glass of pump.	1 One or more diaphragms split or ruptured.	1 Immediately drain oil from pump and flush to remove all spray residues from sump. Remove pump heads & fit new diaphragms. Fill to correct level with motor oil 20W/30.
SUCTION SIDE OF PUMP		
F Suction hose vibration.	1 Air getting into suction.	1 Seal all joints securely with tape or stag. Firm up clamps.
G Pump valves hammering.	1 Suction tap partly turned off. 2 Suction strainer(s) blocked.	1 Turn tap fully on. 2 Clean filters.
H No water flow on suction hose.	1 Obstruction in tank or suction line.	1 Clean foreign material from tank & suction line.
DISCHARGE SIDE OF PUMP		
I Pressure gauge pointer swings violently.	1 Pressure control valve spindle doesn't move easily.	1 Lubricate with light oil or C.R.C.
J AR control valve leaking from spindle.	1 Split diaphragm or O-rings.	1 Remove 4 body set screws, replace diaphragm and O-rings.
K Pressure gauge showing correct working pressure no pressure at nozzle.	1 Burst discharge line. 2 Blocked discharge filter where fitted. 3 O-ring(s) jamming flow in discharge line. 4 Ants, wasps build nests in discharge line or nozzles.	1 Replace discharge line. 2 Clean discharge filter. 3 Clean discharge line of foreign materials. 4 Clean nozzles of foreign materials with tooth brush

PROBLEM	PROBABLE CAUSE	REMEDY
1 No spray when turned on.	<ol style="list-style-type: none"> 1 Filter on the inlet side of the pump blocked. 2 Faulty pump. 	<ol style="list-style-type: none"> 1 Dismantle, clean & re-assemble. 2 Change pump.
2 Sprays for short time only.	<ol style="list-style-type: none"> 1 Air inlet to tank blocked. 2 Filter on suction side of pump blocking or blocked. 	<ol style="list-style-type: none"> 1 Clean air vent. 2 Dismantle, clean & re-assemble the filter. If filter problem persists, clean out the tank & start again.
3 Spray is uneven around the boom.	<ol style="list-style-type: none"> 1 Some nozzle filters or tips are blocked. 2 Nozzle tips worn. 3 Different pressure along the boom. 	<ol style="list-style-type: none"> 1 Remove, clean & check. Check output & for streaks. 2 Check nozzle output, replace worn nozzles. 3 Remove a nozzle in each boom section & check that flow rate is the same. If different, check for blockages.
4 Pressure going up - output going down.	<ol style="list-style-type: none"> 1 Nozzle filters blocking. 	<ol style="list-style-type: none"> 1 Dismantle, clean & refit. Check pressure returns to normal. Check all filters and spray mixture.
5 Pressure falling.	<ol style="list-style-type: none"> 1 Filter on suction side blocked. 2 Nozzle tips worn. 3 Pressure gauge faulty. 4 Pump worn. 	<ol style="list-style-type: none"> 1 Dismantle & clean the filter. 2 Check nozzle output, replace worn nozzles. 3 Check with new pressure gauge. 4 Repair or replace the pump.
6 Spray pattern narrow.	<ol style="list-style-type: none"> 1 Pressure too low. 2 Pressure too low & spluttering. 	<ol style="list-style-type: none"> 1 Check that the correct nozzles are being used. 2 Check that the tank is not empty. If not, there is an air leak between the pump & tank or in the pump. Check plumbing & repair.
7 Foam in the tank.	<ol style="list-style-type: none"> 1 Too much agitation. 	<ol style="list-style-type: none"> 1 Check that the return line is at the bottom of the tank. Partly close agitation and valve
8 Spray pattern streaky.	<ol style="list-style-type: none"> 1 Nozzle partly blocked. 	<ol style="list-style-type: none"> 1 Remove & clean. If it continues, the nozzle is damaged. Replace with same size tip, check flow rate of replacement nozzle.

PROBLEM	PROBABLE CAUSE	REMEDY
A Hydraulic system overheating	<ol style="list-style-type: none">1 Improper hydraulic motor size.2 Bypass adjustment screw set to bypass too much oil.3 Insufficient hydraulic hose size.	<ol style="list-style-type: none">1 Refer to pump selection guide to determine proper size for your system.2 Close adjustment screw on side of hydraulic motor to lessen the amount of bypassing oil.3 Check hydraulic hose size. Hose should be at least ½". For large open-centre systems ¾".

PROBLEM	PROBABLE CAUSE	REMEDY
A Marker doesn't run at all	<ol style="list-style-type: none"> 1 Harness plug not plugged in or 2 Circuit breaker popped or fuse blown. 	<ol style="list-style-type: none"> 1 Check all wiring plugs and connections. 2 Check breaker/fuse and reset/replace if necessary.
B Air pump runs – nothing coming out – no pressure showing on gauge	<ol style="list-style-type: none"> 1 Liquid pump shut Off or not primed. (Hint: When working on liquid pump, it is helpful to unplug the air pump so you can hear the liquid pump running. Remove the two black wires from the air pump and clamp them together). 2 Electronic speed control failed causing liquid pump not to run. (Hint: When working on liquid pump, it is helpful to unplug the air pump so you can hear the liquid pump running) 3 Liquid pump valves or diaphragm have failed. 4 Liquid pump motor failed. 	<ol style="list-style-type: none"> 1 Turn liquid control knob clockwise as far as it will go. This will run the pump at full speed to aid in priming. Allow a minute or two to prime. If it still won't prime, find the liquid orifice assembly near the discharge of the pump & uncouple briefly to allow air pressure to be relieved. If it still doesn't prime, either the tank strainer/outlet is completely plugged or the pump needs service or replacement. 2 Check this component by feeling and listening to the motor while you turn the knob up & down. If it speeds up & slows down, the control & pump motor are OK. If not, unplug the liquid pump from the speed control. Using jumper wires, apply 12 Volts DC directly to the liquid pump. It should run full speed indicating the pump is OK & the Speed Control is not working. Check polarity of wires to power supply. speed control will not operate in reverse polarity. If you're absolutely sure it is correct, replace the electronic speed control. 3 If the liquid pump appears to run normally as described above, but can't prime or pump the liquid, it may need a new diaphragm, or valve cartridge. We suggest replacing both. 4 If you've determined in the above step the liquid pump did not work when 12 Volts was applied, replace pump motor or whole pump.
C Nothing coming out – high pressure showing	<ol style="list-style-type: none"> 1 Liquid orifice plugged. 	<ol style="list-style-type: none"> 1 Find liquid orifice assembly near outlet of liquid

PROBLEM	PROBABLE CAUSE	REMEDY
D Discharges almost all water - Air Flow Restricted	<ol style="list-style-type: none"> 1 Air On/Off solenoid valve doesn't operate. 2 Pressure regulator incorrectly adjusted. 3 Pressure regulator damaged. 4 Air discharge plugged. 	<ol style="list-style-type: none"> 1 Check for 12V to solenoid. If not, check for electrical issues. If so, replace air ON/Off solenoid valve. 2 Set pressure regulator to 28 psi. 3 Replace pressure regulator. 4 Inspect air check valve located near solenoid discharge for proper operation.
E Discharge foamy but very watery	<ol style="list-style-type: none"> 1 Concentrate weak or water too hard. 2 Liquid pressure too high. 3 Air supply not operating or plugged. 	<ol style="list-style-type: none"> 1 Strengthen concentrate mixture or add water conditioner. If this doesn't work, try a different water supply. 2 Reduce liquid pressure to under 40 psi. 3 See air pump remedies above. Service air cleaner.
F Not enough foam	<ol style="list-style-type: none"> 1 Foam quality poor or weak air supply. 	<ol style="list-style-type: none"> 1 Measure the output by catching in a bucket. If output exceeds 20 litres/min, the marker is working at full capacity. If not, make sure foam quality is good as described above. Also, low output can be related to poor air supply performance. See description above.
G Foam goes to wrong side	<ol style="list-style-type: none"> 1 Left-Right hoses hooked up backwards. 	<ol style="list-style-type: none"> 1 Reverse hoses on Directo-Valve.
H Foam won't switch sides	<ol style="list-style-type: none"> 1 No power to valve. 2 Valve failure. 	<ol style="list-style-type: none"> 1 Check electrical connection to the valve 2 Replace valve.
I Foam comes out both sides at the same time	<ol style="list-style-type: none"> 1 Valve Failure 	<ol style="list-style-type: none"> 1 Replace valve.

PROBLEM	PROBABLE CAUSE	REMEDY
A Air compressor runs constantly.	1 Air leakage in the system.	1 Find the air leak. Test by using full air pressure and applying soapy water. Fix any air leaks. Use Loctite 569 on all air threads.
B Airbags lose pressure (when left standing for less than a week).	1 Air leakage in the system. 2 Uneven valve settings. 3 Leaky/dirty valve.	1 Find the air leak by using soapy water to test. Fix any air leaks. 2 Adjust the valve settings (see page 41). 3 Drain air chamber. Clean/replace the valve.
C Airbags not responsive	1 Worn linkage grommets. 2 Hard, non-pliable grommets. 3 Grommets loose on rods.	1 Replace worn grommets. 2 Replace new pliable grommets. 3 Tighten loose grommets.

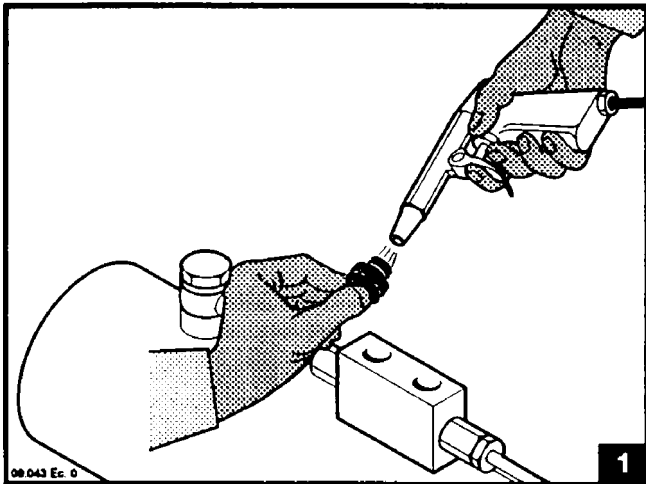

Problem:

The boom unfolds halfway and then stops.

Probable Cause:

Impurity in calibrated joint during assembly of cylinders.

Remedy:

Disassemble joints and clean, shown in figure 1

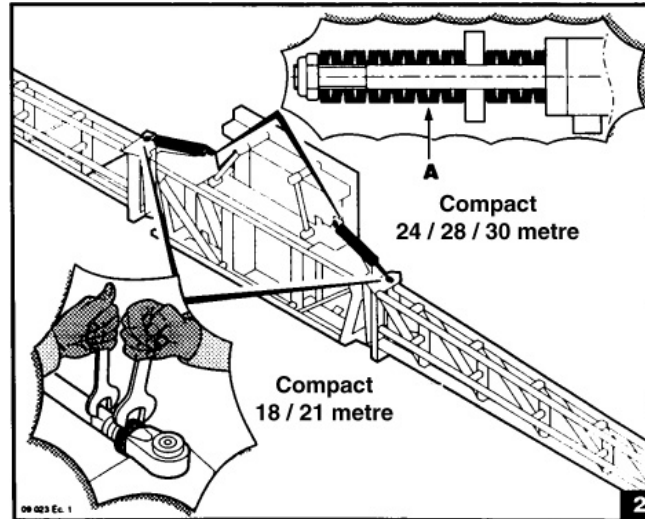
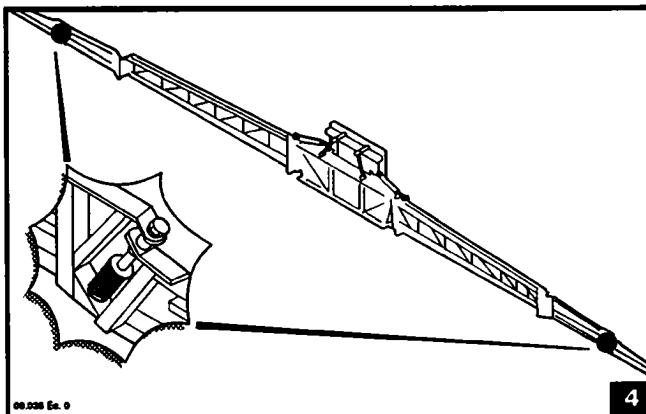

Problem:

The boom does not align when unfolding.

Probable Cause:

- 1 Ball joint of the unfolding cylinder not adjusted.
- 2 Shock absorber springs (A) not adjusted or damaged.

Remedy:

- 1 Adjust the joint according to the "Wing Alignment" instructions on page 3.12 to 3.16.
- 2 Check the springs; replace them if damaged see figure 2.

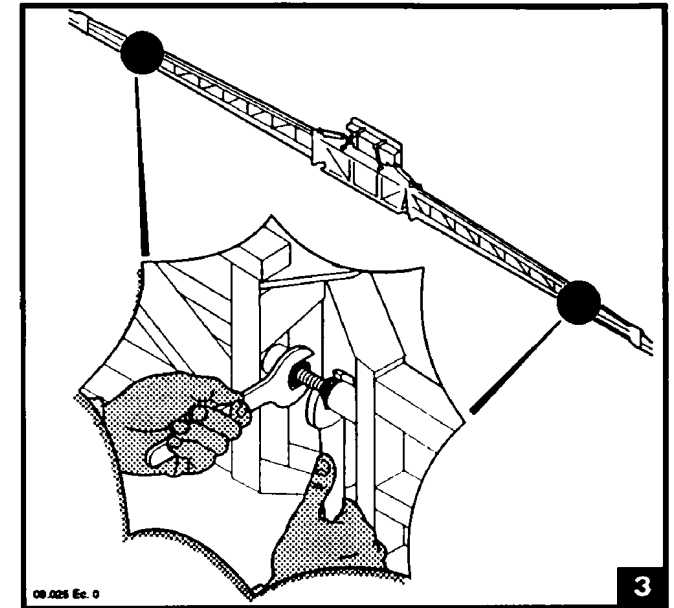

Problem:

The wing extensions do not align when folding.

Probable Cause:

Stop bolt not adjusted.

Remedy:

Adjust the screw to obtain alignment, as shown in figure 3.

Problem:

The ball joint of the wing extension moves during the unfolding and folding operation.

Probable Cause:

Loose joint.

Remedy:

Compress the spring, as shown in figure 4 (left).

PROBLEM	PROBABLE CAUSE	REMEDY
A Boom line valve opens when it should be closed and closes when it should be open.	1 Wiring incorrect.	1 Reverse polarity of valve by changing wires at the valve cap.
B Water leaks past valve when valve is shut.	1 Worn seat.	1 Replace seat/hosetail and/or valve system if necessary.
C Valve won't operate.	1 No power to valve. 2 Motor failure. 3 Valve clogged.	1 Check all connections, supply - loom. 2 Replace motor. 3 Clean internals of valve and/or put a new valve kit in the valve.
D Servo valve not regulating flow.	1 Valve jamming. 2 No power. 3 Valve clogged.	1 Clean our valve or replace. 2 Check all power leads and supply, or replace motor. 3 Clean out valve and/or put a new valve kit in the valve.
E Dump valve not releasing pressure in system on shut-off.	1 No power to valve. 2 Valve motor failed. 3 Dump-line blocked.	1 Check power supply and all connections. 2 Check motor and replace if required. 3 Clean valve and return line.

AR160/185 Pump	7.2
AR250 Pump	7.4
Liquid Control System	7.6
Rotary Valves	7.8
Liquid System	7.9
Filling System	7.10
Valves - Transfer Kit	7.11
EnviroTransfer Kit - AR180/AR250	7.12
Chem E Flush Assembly	7.14
Filters	7.16
Lids, Venturis & Tank Rinse Jet	7.17
Foam Marker Components	7.18
Foam Markers - Outback 10	7.19
Boom Fittings	7.20
Nozzles & Nozzle Bodies	7.21
Chassis, Tank & Wheels	7.22
Axles & Stub Axles	7.24
Compressor & Air Tank	7.29
Air Ride Suspension System	7.30
Electrical Wiring	7.31
Plumbing Diagrams	7.33
Hydraulic Diagrams	7.35
Booms	7.50

AR160/185 Pump

Assembly Drawings & Parts

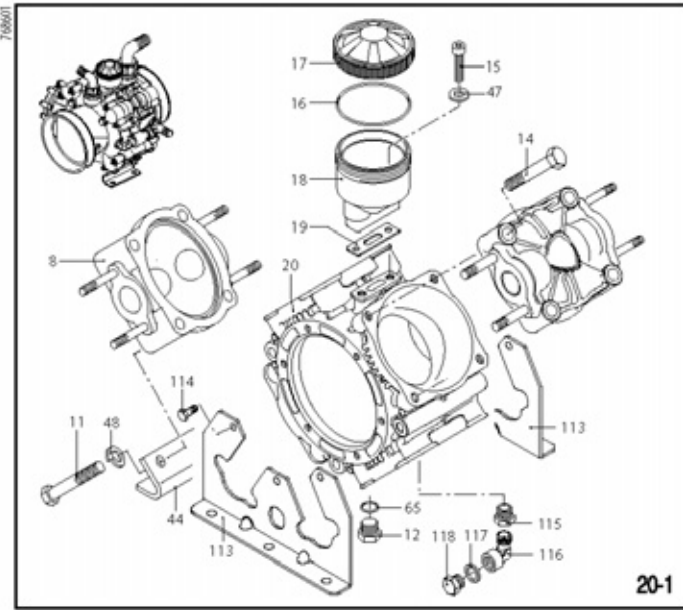

SL00209-AU

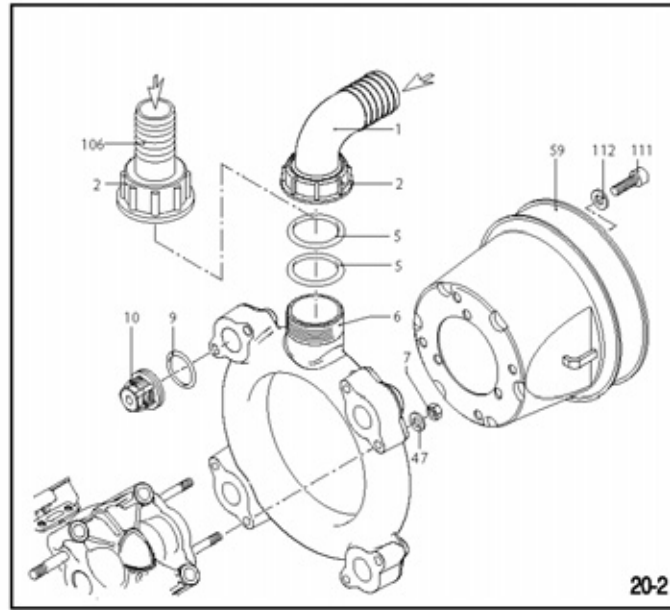

SL000155-DV

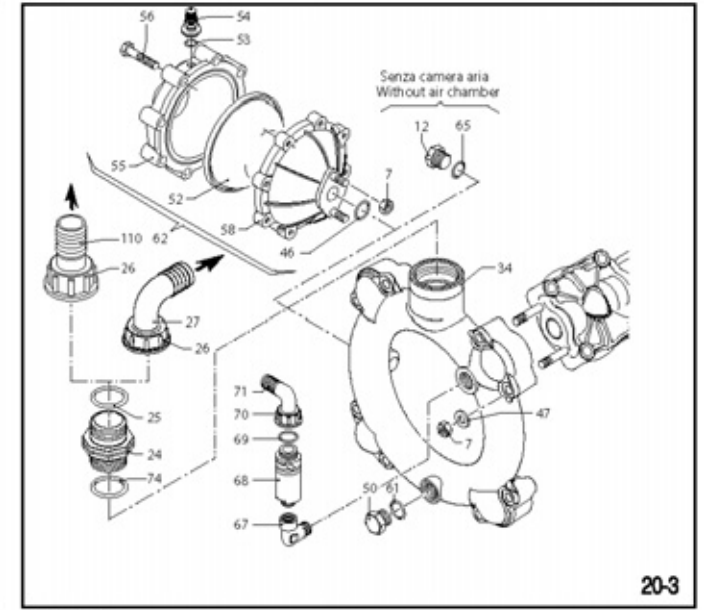

SL000156-DV

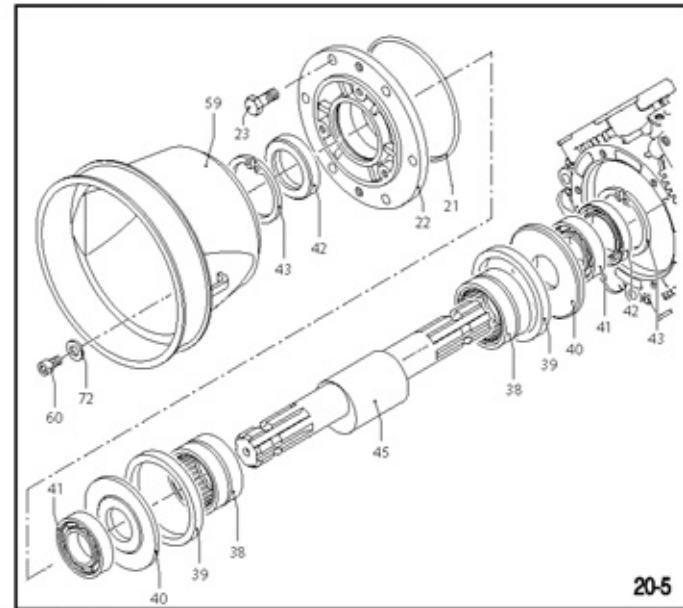

SL0000715-IB

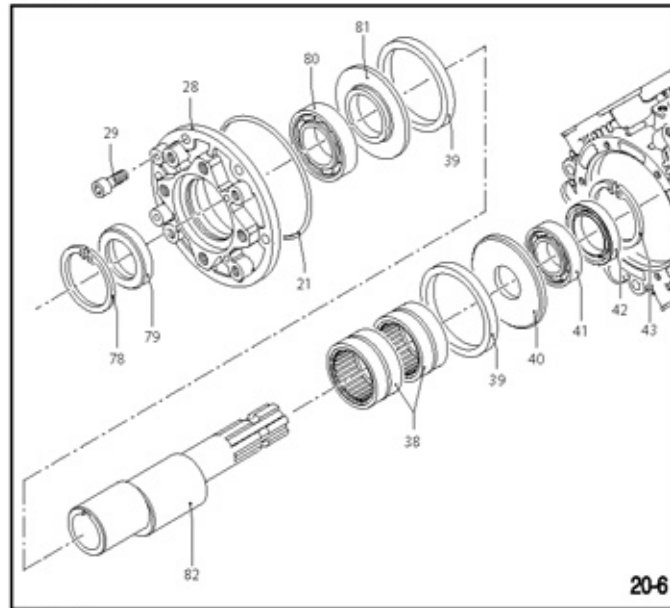

SL0000715-IB

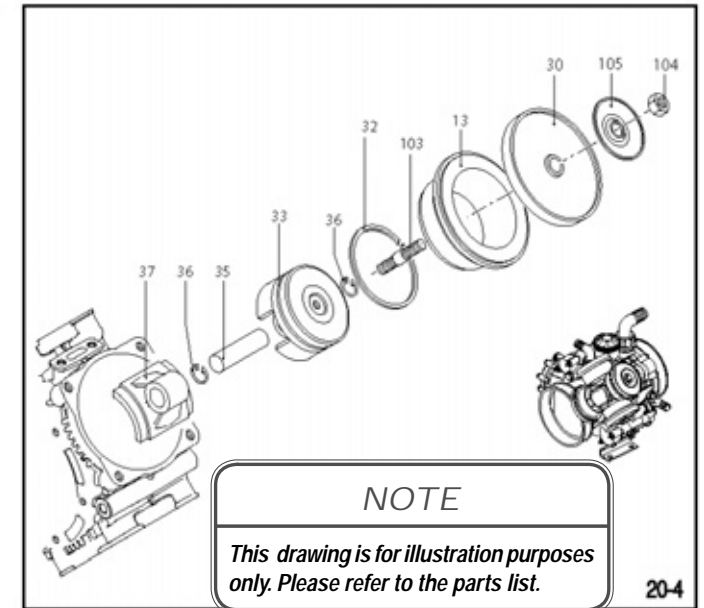

SL000208-AU

NOTE
 This drawing is for illustration purposes only. Please refer to the parts list.

Pos	Part No	Description	Qty
1	AR3040430	Ø 40 Elbow - AR 160 bp	1
	AR3040440	Ø 50 Elbow - AR 185 bp	1
2	AR3040450	2" G Ring nut	1
5	AR3040470	OR Ø 39.3 x 2.6 O-ring	2
6	AR760750	Line	1
7	AR380242	M8 Nut - Geomet C 20	18
	AR380244	M8 Nut - Inox C 20	18
8	AR751350	Head	4
	AR751352	Head	4
9	AR680070	OR Ø 31.5 x 4.25 O-ring	8
10	AR759051	Valve	8
11	AR750071	TE M12 x 70 Screw - Geomet C 50	4
	AR750072	TE M12 x 70 Screw	4
12	AR880530	3/8" G Plug - C 20	2
	AR2340350	3/8" G Plug - Inox C 20	2
13	AR750110	Sleeve - AR 160 bp	4
	AR750115	Sleeve - AR 185 bp	4
14	AR750061	TE M12 x 65 Screw - Geomet C 50	12
	AR750062	TE M12 x 65 Screw - Inox C 50	12
15	AR680350	TCEI M8 x 35 Screw	2
16	AR1040060	Ø 72.69 x 2.62 O-ring	1
17	AR750057	Plug - AR 160 bp	1
	AR750052	Plug - AR 185 bp	1
18	AR750030	Tank	1
19	AR750040	Gasket	1
20	AR761010	Pump body	1
21	AR851360	Ø 120.32 x 2.62 O-ring	1
22	AR680020	Support	1
23	AR160672	TE M10 x 25 Screw - Geomet C 40	6
	AR160673	TE M10 x 25 Screw - Inox C 40	6
24	AR751130	1"1/2 G M-M Fitting	1
25	AR390290	Ø 29x3 O-ring	1
26	AR750670	1" 1/2 G Ring nut	1
27	AR760930	Ø 25 Elbow - AR 160 bp	1
	AR3040160	Ø 35 Elbow - AR 185 bp	1
28	AR2420181	Support	1
29	AR650640	TCEI M10 x 25 Screw - Geomet C 40	6
	AR650642	TCEI M10 x 25 Screw - Inox C 40	6
30	AR550080	Diaphragm - NBR	4
	AR550084	Diaphragm - Viton	4
	AR550085	Diaphragm - Desmopan	4
	AR550086	Diaphragm - HPDS	4
32	AR500260	Piston ring	4
33	AR750122	Ø 80 Piston	4
34	AR760760	Line	1
35	AR160700	Pin	4
36	AR160691	Øi 18 Ring	8
37	AR760140	Connecting-rod	4
38	AR750090	Bearing	2
39	AR750130	Ring	2
40	AR540040	Plate	2
41	AR230350	Bearing	2
42	AR160740	Ring	2
43	AR200390	Øi 62 Ring	2
44	AR760201	Foot	2
45	AR750170	C/C m-AU Shaft - AR 160 bp	1
	AR750174	C/C m-AV Shaft - AR 185 bp	1

NOTE

Parts in Italics are non-stocked items and may need to be ordered.

Pos	Part No	Description	Qty
46	AR390290	Ø 29x3 O-ring	1
47	AR380243	Washer - Geomet	18
	AR390315	Washer - Inox	18
48	AR250143	Washer - Geomet	4
	AR250144	Washer - Inox	4
50	AR330173	1/2" G Plug - Geomet C 20	1
	AR330174	1/2" G Plug - Inox C 20	1
52	AR550190	Semi air chamber - NBR	1
	AR550191	Semi air chamber - Saturflon	1
	AR550192	Semi air chamber - Viton	1
	AR550193	Semi air chamber - HPDS	1
53	AR650542	Gasket	1
54	AR180020	Air valve	1
55	AR620232	Semi air chamber	1
56	AR621781	TE M8 x 40 Screw	8
62	AR1782	TE M8 x 40 Screw	8
58	AR680180	Halfball	1
59	AR1500470	Cardan protection	2
60	AR850251	M8 x 12 Screw	3
	AR850252	TCEI M8 x 12 Screw	3
61	AR180101	Ø 17.5 x 2 O-ring	1
62	AR1552	Air chamber	1
65	AR740290	Ø 14 x 1.78 O-ring 2	
67	AR881560	1/2" G M-F Fitting 1	
68	AR1609000	Safety valve	1
69	AR880831	Ø 15.54 x 2.62 O-ring - Viton	1
70	AR550450	3/4" G Ring nut	1
71	AR550460	Ø 18 Elbow	1
72	AR390314	Washer - Geomet	3
	AR390315	Washer - Inox	3
74	AR751140	Ø 47.22 x 3.53 O-ring	1
78	AR620330	Øi 65 Ring	1
79	AR1800090	Ring	1
80	AR230310	Bearing	1
81	AR760510	Plate	1
82	AR760450	C/F Ø25 m-BX Shaft - AR 160 bp	1
	AR760520	C/F Ø32 m-BS Shaft - AR 160 bp	1
	AR760460	C/F Ø25 m-BZ Shaft - AR 185 bp	1
	AR760530	C/F Ø32 m-BT Shaft - AR 185 bp	1
103	AR2240100	Hub pin	4
104	AR2240110	M10 Nut	4
105	AR751250	Wobble plate	4
106	AR760950	Ø 40 Hose tail - AR 160 bp	1
	AR760570	Ø 50 Hose tail - AR 1854 bp	1
110	AR760920	Ø 25 Hose tail - AR 160 bp	1
	AR760940	Ø 35 Hose tail - AR 185 bp	1
111	AR820673	TCEI M10 x 16 Screw - Geomet	3
	AR820672	TCEI M10 x 16 Screw - Inox	3
112	AR320621	Washer 3 Geomet	
	AR320622	10.5 x 21x 2 Washer - Inox	3
113	AR761030	Foot	2
114	AR160672	TE M10 x 25 Screw - Geomet C 20	6
	AR160673	TE M10 x 25 Screw - Inox C 20	6
115	AR1040491	3/8" M-F Fitting	1
116	AR900210	3/8" G M-F Fitting	1
117	AR2260200	Washer	1
118	AR2281270	3/8" G Plug	1

AR250 Pump

Assembly Drawings & Parts

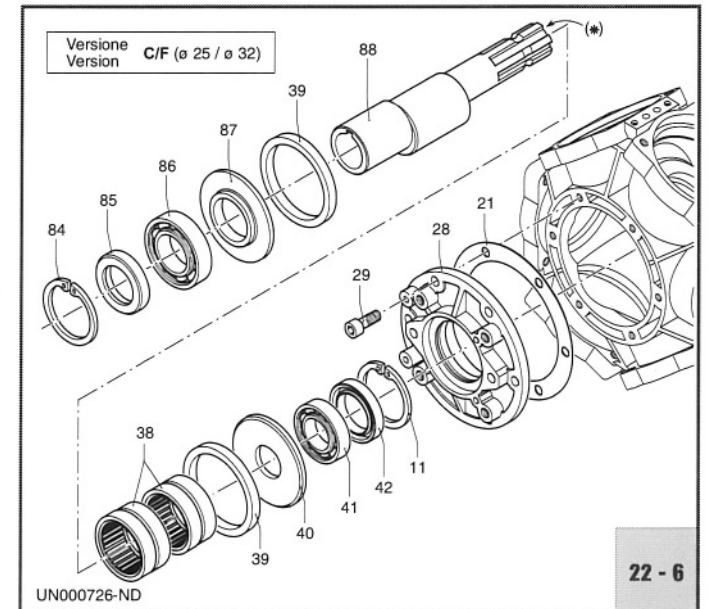
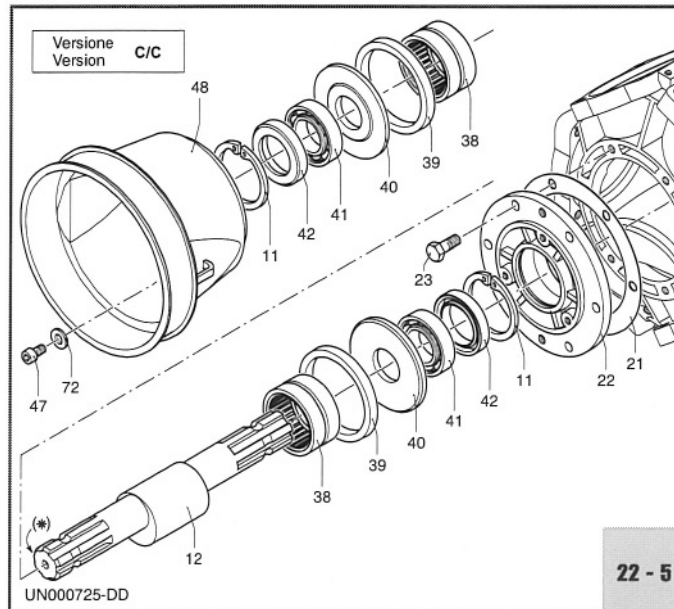
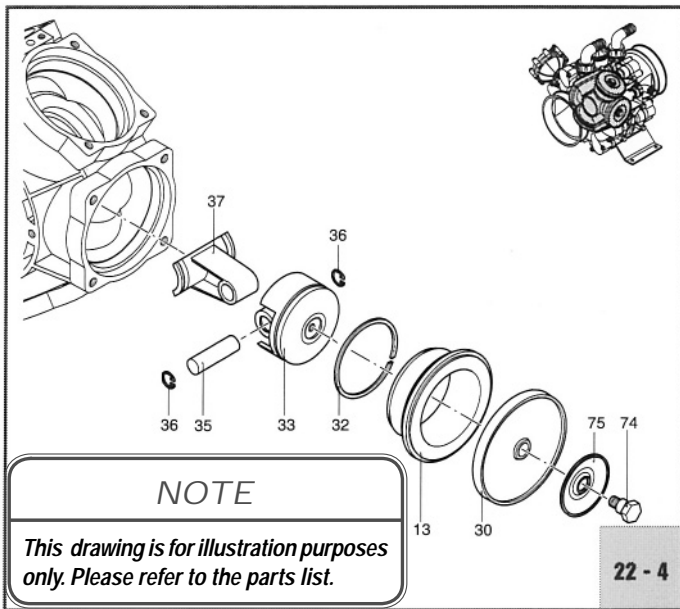
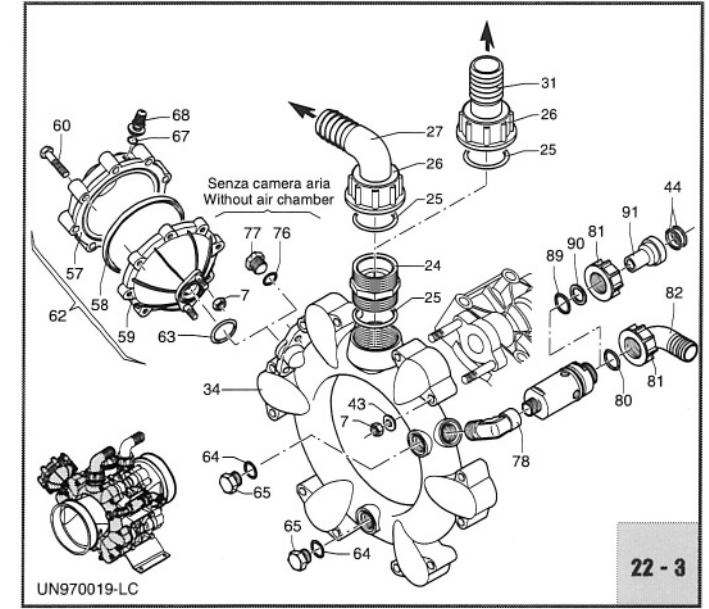
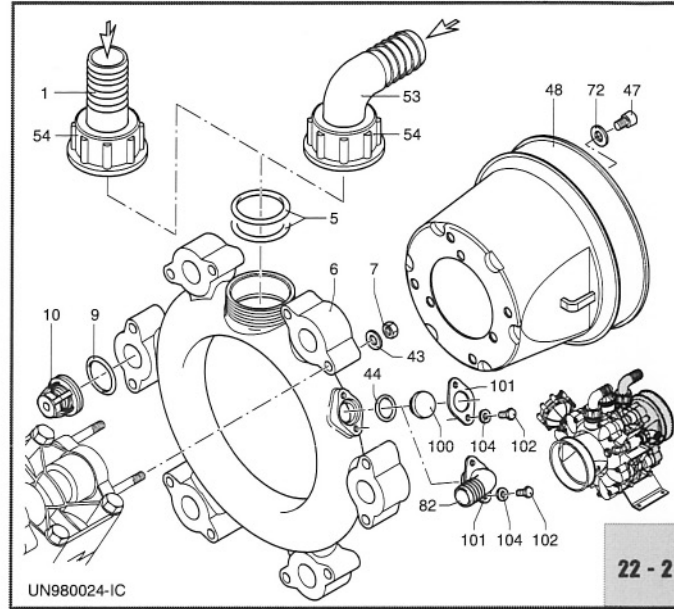
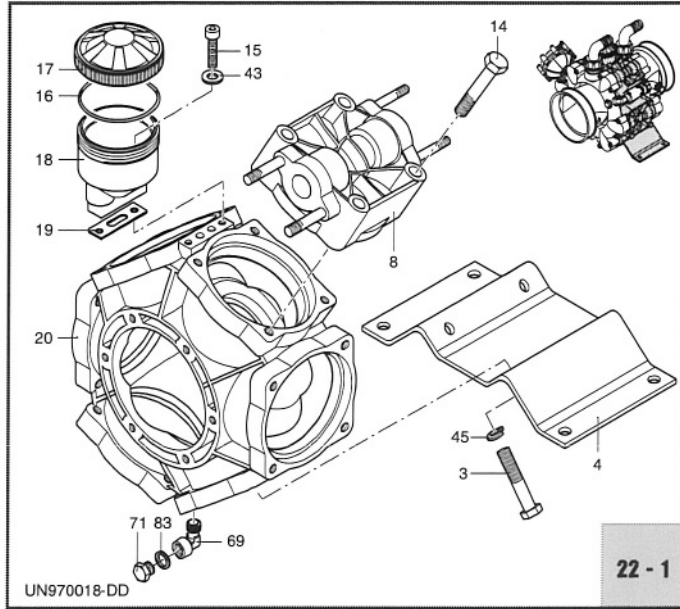

Pos	Part No	Description	Qty
1	AR750870	<i>ø 50 Hose tail</i>	1
	AR750730	<i>ø 60 Hose tail</i>	1
3	AR750071	<i>M12 x 70 Bolt</i>	4
4	AR750200	Base plate	1
5	AR750740	74 x 3.53 O-Ring	2
6	AR750860	Suction manifold	1
7	AR380242	<i>Nut</i>	26
8	AR750100	Head	6
9	AR680070	O-Ring	12
10	AR759051	Complete valve	12
11	AR200390	Circlip	2
12	AR750170	Crankshaft AR 250 bp (AU)	1
13	AR750110	<i>Sleeve AR 250 bp</i>	6
14	AR750061	<i>M 12x65 Bolt</i>	20
15	AR680350	M8 x 35 Bolt	2
16	AR1040060	O-Ring	1
17	AR750057	<i>Black oil tank cap AR 250 bp</i>	1
18	AR750030	Oil tank	1
19	AR750040	Gasket	1
20	AR750010	Pump body	1
21	AR680250	Gasket	1
22	AR680020	<i>Shaft support</i>	1
23	AR160672	<i>M 10x25 Bolt</i>	6
24	AR540530	1"1/4-1"3/4 G (M) Threaded adapter	1
25	AR250310	O-Ring	2
26	AR540540	1"3/4 G Ring nut	1
27	AR392130	<i>ø 35 Elbow</i>	1
28	AR2420180	<i>Shaft support</i>	1
29	AR621500	<i>M10 x 25 Bolt</i>	6
30	AR550084	<i>Diaphragm - VITON</i>	6
	AR550086	Diaphragm - HPDS (Recommended)	6
31	AR391930	<i>ø 35 Hose tail Optional</i>	1
32	AR500260	Piston ring	6

Pos	Part No	Description	Qty
33	AR750122	Piston 80mm	6
34	AR750420	Manifold	1
35	AR160700	Pin	6
36	AR160691	Pin circlip	12
37	AR750140	<i>Connecting rod</i>	6
38	AR750090	Roller bearing	2
39	AR750130	Con rod ring	2
40	AR540040	<i>Spacer washer</i>	2
41	AR230350	Bearing	2
42	AR160740	Seal Ring 35 x 52 x 12mm	2
43	AR380243	<i>Washer</i>	26
44	AR480440	O-Ring	3
45	AR250143	<i>Washer</i>	4
47	AR850251	<i>M8 x 12 Bolt</i>	6
48	AR1500350	Shaft guard	2
53	AR750850	<i>ø 50 Elbow AR 250 bp</i>	1
54	AR750710	2"1/2 G Ring nut	1
57	AR620232	<i>Upper air chamber</i>	1
58	AR550190	Semi air chamber - RUBBER	1
	AR550192	<i>Semi air chamber - VITON</i>	1
	AR550193	<i>Semi air chamber - HPDS</i>	1
59	AR680180	Lower air chamber	1
60	AR621781	<i>M8 x 40 Bolt</i>	8
62	AR1552	Complete air chamber	1
63	AR390290	O-Ring	1
64	AR180101	O-Ring	2
65	AR330173	<i>1/2" G Plug</i>	2
67	AR650542	Gasket	1
68	AR180020	Air valve	1

NOTE

Parts in Italics are non-stocked items and may need to be ordered.

Electric Pressure Dump Valve, Manual Pressure Relief Valve, Electric Regulating Valve (Servo) and Flowmeter for AR185 Pumps



Liquid Control System - Complete Valve Assembly (Part No: A471CCRO01)

Manual Regulator-Dump Valve Assembly

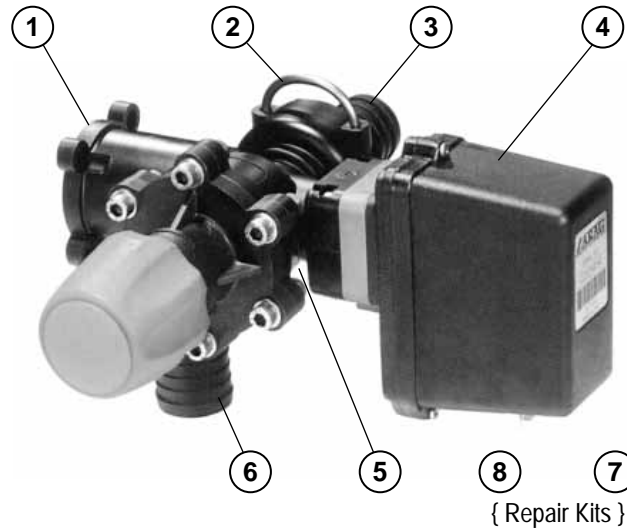

Pos	Part No	Description	Qty
1	A471502	Complete Regulator	1
2	A010005	Clip	1
3	A471202.A32	Bypass Tail	1
4	A4653920S	Valve Motor	1
5	A010003	Clip	1
6	A473001.A32	Inlet Tail	1
7	A471502.550	Dump Valve kit	1
8	A471502.180	Regulator kit	1

{ Repair Kits }

Electric Regulating Valve

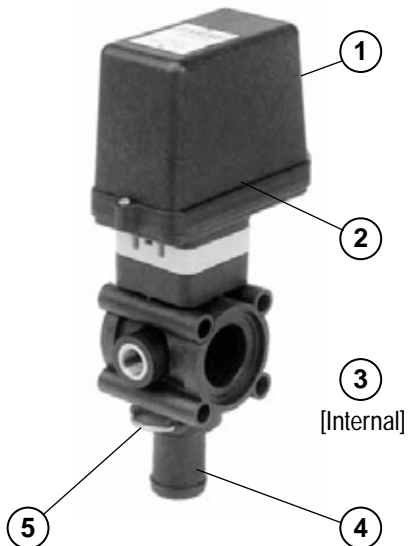

Pos	Part No	Description	Qty
1	A463024S	Complete Valve	1
2	A4653925S	Motor	1
3	A473020.130	Regulator Stem Kit	1
4	A473001.A25	Tail/Seat	1
5	A010002	Clip	1

[Internal]

Flowmeter Assembly

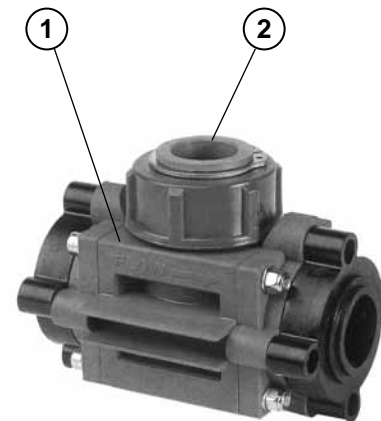

Pos	Part No	Description	Qty
1	POL00375908A	Complete Valve	1
2	POL41316399	Rapid Check Turbine Assembly	1
3	POL413003AK.CR	Sensor with Plug	1

Electric Pressure-Dump Valve, Electric Regulating Valve (Servo), Manual Pressure Relief Valve and Flowmeter for AR250/280 Pumps

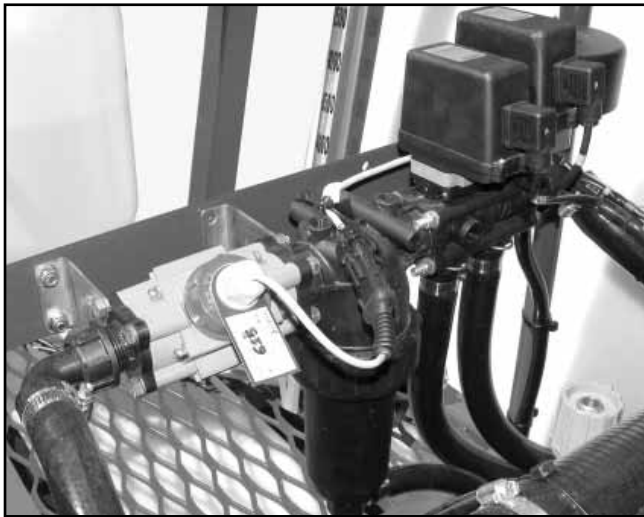

Liquid Control System - Complete Valve Assembly (Part No: A473CCRO01)



Dump Valve

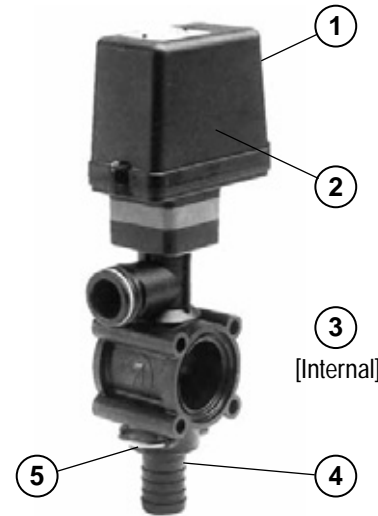

Dump Valve Parts

Pos	Part No	Description	Qty
1	A473001	Complete Valve	1
2	A4653920S	Motor	1
3	A473011.550	Regulator Stem Kit	1
4	A473001.A25	Tail/Seat	1
5	A010003	Clip	1

Manual PRV Parts

Pos	Part No	Description	Qty
1	A465522	Complete Regulator	1
2	A465005.180	Regulator kit	1

Electric Regulating Valve

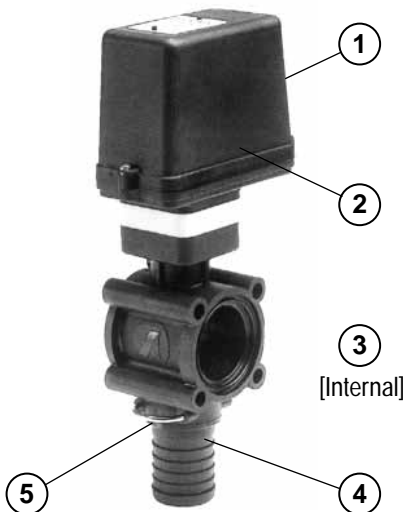

Pos	Part No	Description	Qty
1	A473020S	Complete Valve	1
2	A4653925S	Motor	1
3	A473020.130	Regulator Stem Kit	1
4	A473001.A25	Tail/Seat	1
5	A010003	Clip	1

Flowmeter Assembly

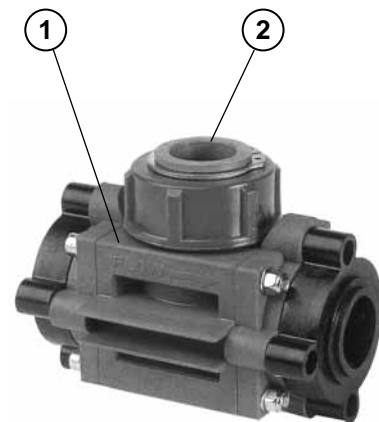

Pos	Part No	Description	Qty
1	POL00375908A	Complete Valve	1
2	POL41316399	Rapid Check Turbine Assembly	1
3	POL413003AK.CR	Sensor with Plug	1

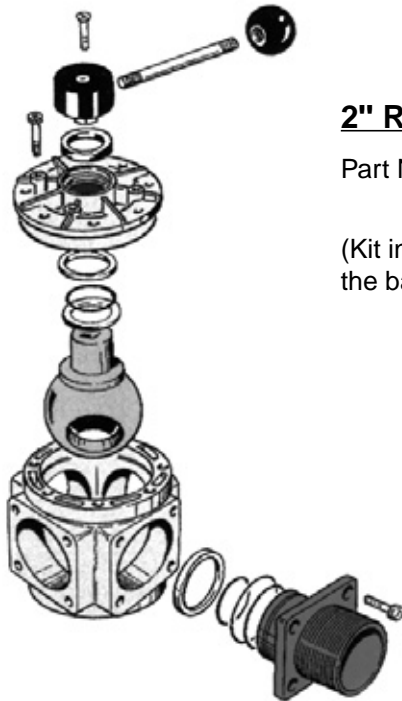
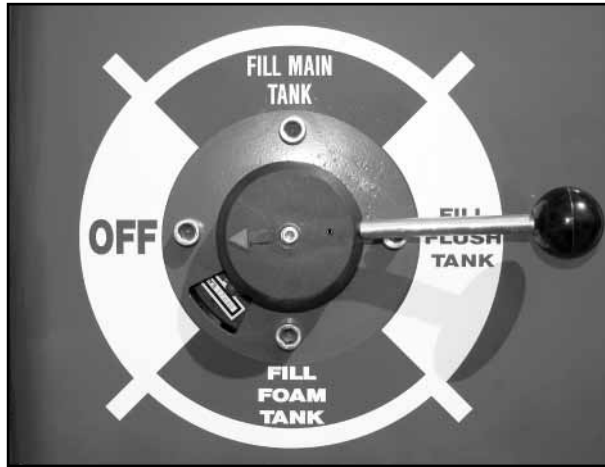

2" Rotary Valve

Part No: POL10405899.
Seal Kit (5 pieces).

(Kit includes seals & O-rings, but not the ball, body or fittings).

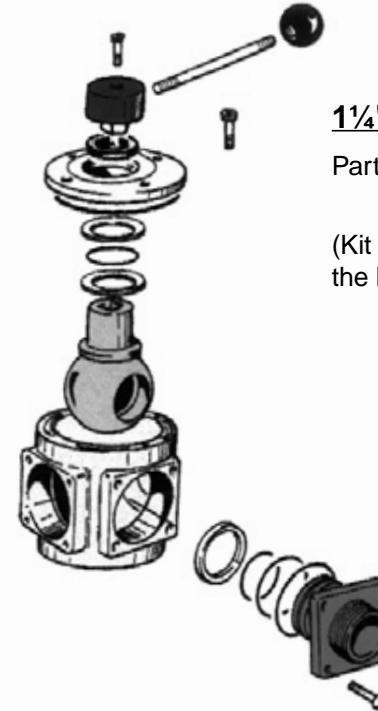

1 1/4" Rotary Valve

Part No: POL10424399
Seal Kit (5 pieces).

(Kit includes seals & O-rings, but not the ball, body or fittings).

Boom Shut-Off Valves, Pressure Gauge & Control Valve/Taps



Boom Shut-Off Valves

Boom Shut-Off Valve (each)

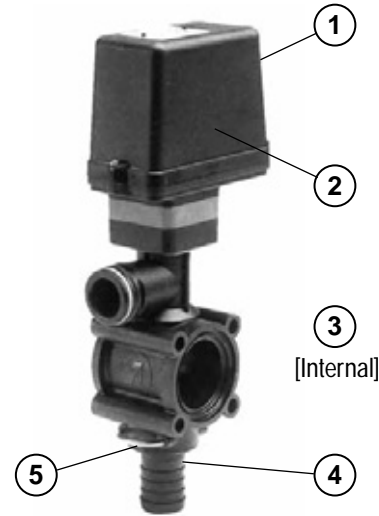

Pos	Part No	Description	Qty
1	A463011ST	Complete Valve	1
2	A4653920S	Motor	1
3	A473011.550	Regulator Stem Kit	1
4	A473001.125	Tail/Seat	1
5	A010003	Clip	1



Shut-Off Taps - Tank Rinse, Probe Rinse & Agitators

Pressure Gauge: L-G 1611

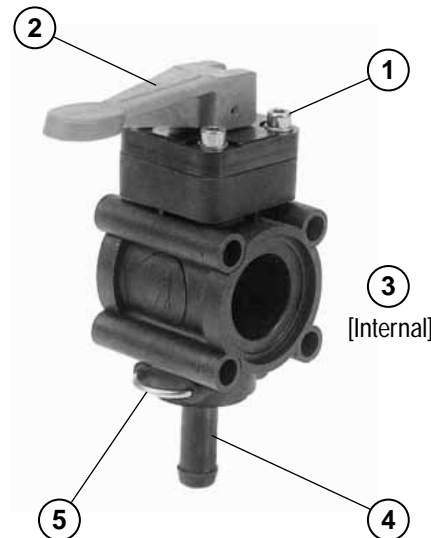

Pos	Part No	Description	Qty
1	A463051	Complete Valve	1
2	A463051.140	Handle	1
3	A463051.550	Regulator Stem Kit	1
4	A463001.A13	Tail	1
5	A010002	Clip	1



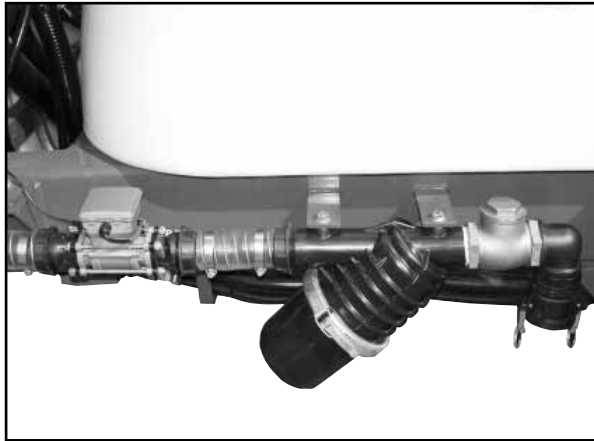

Filling System with Camlok

Orion Filling Flow-meter



Pos	Part No	Description	Qty
1	A4622BA61717	Orion Complete	1

Non-Return Valve 2"

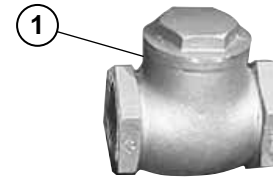

Pos	Part No	Description	Qty
1	BP-112A	Valve complete	1

Filter

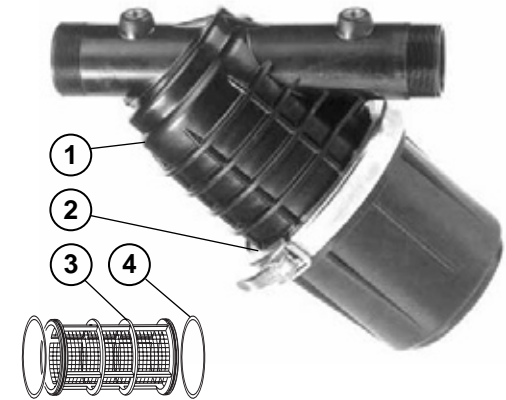

Pos	Part No	Description	Qty
1	A333072	Filter Complete	1
2	A333000.050	Main Seal O-Ring	1
3	A317003.030	Screen - internal	1
4	A316300.060	Filter O-Rings	2

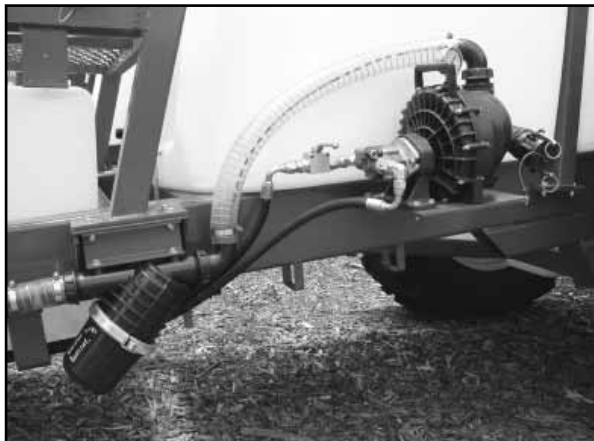

Filling System with Filling Pump

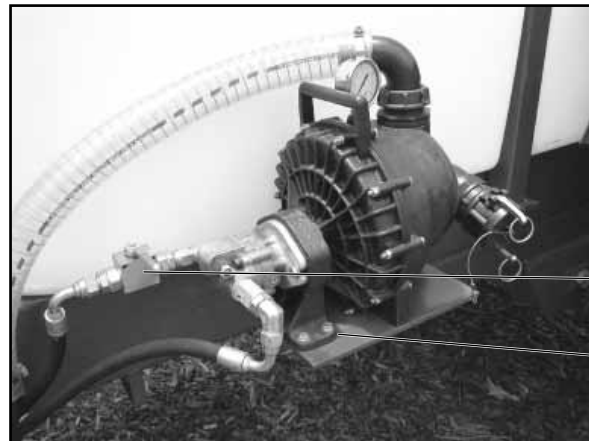

Pos	Part No	Description	Qty
1	200PHY	Pump & Hydraulic Motor Complete	1
2	BP-626S	Hydraulic Hose & Tap Kit (short drawbar)	1
	BP-626L	Hydraulic Hose & Tap Kit (long drawbar)	1
3	HY1003	Hydraulic Repair Kit	1



Drain Valve 2"



Pos	Part No	Description	Qty
1	A454137	Valve Complete	1
2	A454236.050	Tap Handle	1
3	A-EL200	Tail	1



Spray/Off/Flush Valve 1 1/2"

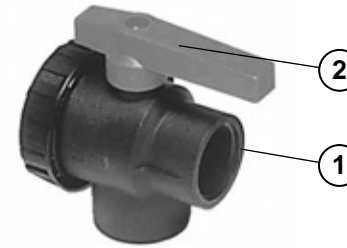

Pos	Part No	Description	Qty
1	A454236	Valve Complete	1
2	A454236.050	Tap Handle	1



Boom Flushing Tap

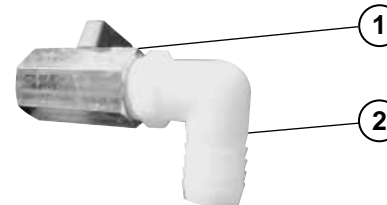

Pos	Part No	Description	Qty
1	BALL12F2M	Valve Complete	1
2	BJHB050/075-90	Elbow	1



Enviro-Transfer Taps (if fitted)

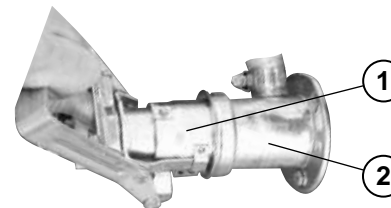

Pos	Part No	Description	Qty
1	L-H9562	Male Coupler	1
2	L-H9556	Female Rinsing Socket	1

Part No: **L-H9366/250**

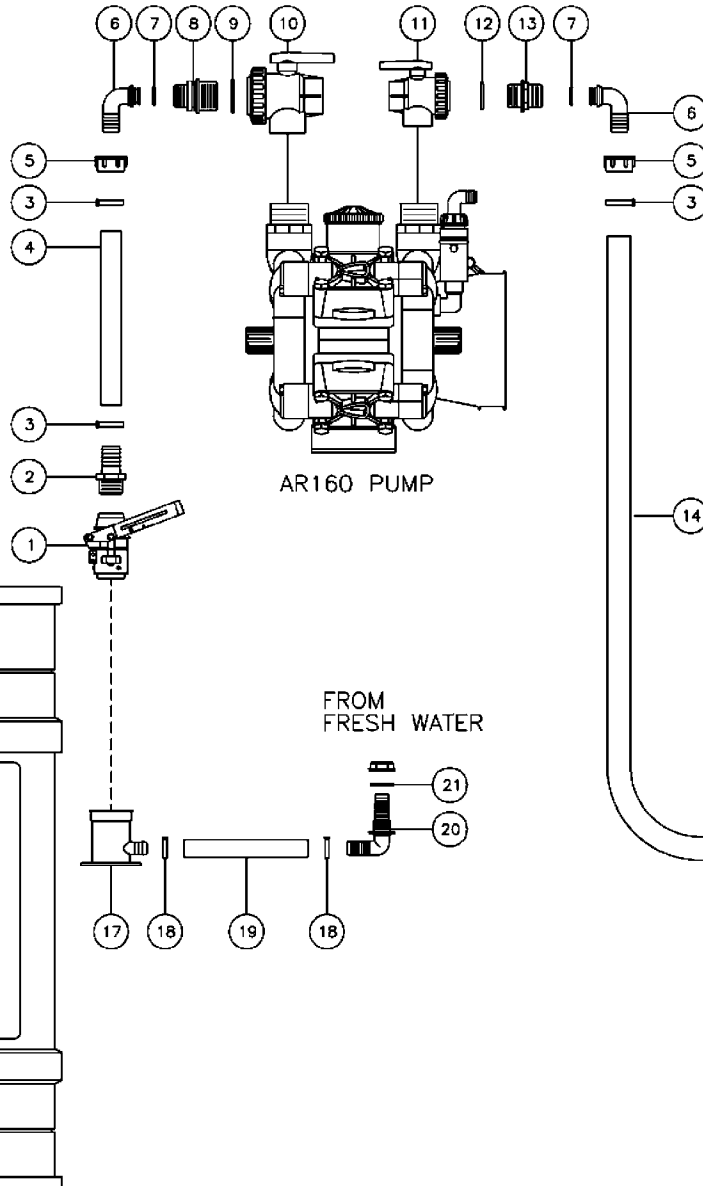

Pos	Part No	Description	Qty
1	L-H9562	COUPLER 3 PIN VITON	1
2	A-A1010	HOSEBARB 1" THREAD (M) X 1" HOSE	1
3	TR1HC	HOSE CLAMP 25mm	4
4	<i>HEP25</i>	<i>SUCTION HOSE 25mm</i>	<i>3 m</i>
5	A200010	FLY NUT 1"	2
6	A116425	ELBOW 0.25 FOR FLY NUT	2
7	AG10041	O-RING	2
8	A250050	NIPPLE 1" - 1¼" REDUCING	1
9	AG10071	O-RING VITON	1
10	A454235H	VALVE, BALL POLY 1¼" 3 WAY	1
11	BJV200BL	VALVE, BALL POLY 2" 3 WAY	1
12	A54235.090	O-RING (BALL VALVE)	1
13	A2502070	NIPPLE 2"	1
14	HPW25	PRESSURE HOSE 25mm	3 m
15	A118426	PIPE 1" X 1" SINGLE PIPE 90 DEGREE	1
16	AG40004	FLAT SEAL 1" EPDM	1
17	L-H9556	RINSING SOCKET	1
18	TR34HC	HOSE CLAMP	2
19	HSC20	SUCTION HOSE 20mm	2 m
20	A118319	PIPE 1" X 1" SINGLE PIPE 90 DEGREE	1
21	AG40003	O-RING	1
22	<i>60 LITRE CHEMEFLUSH (NOT SUPPLIED)</i>	<i>60 LITRE CHEMEFLUSH (NOT SUPPLIED)</i>	<i>1</i>
23	<i>DROP DOWN BRACKET (NOT SUPPLIED)</i>	<i>DROP DOWN BRACKET (NOT SUPPLIED)</i>	<i>1</i>

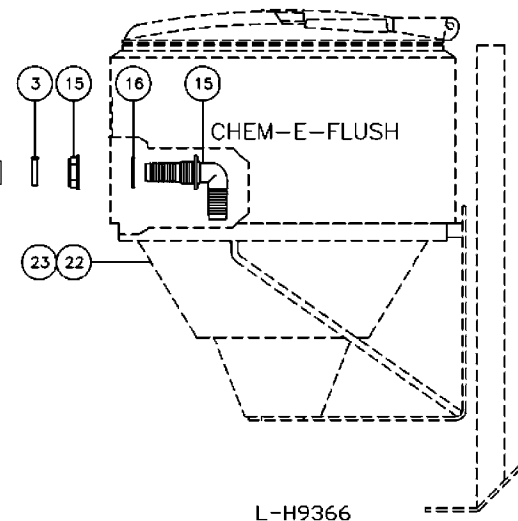

L-H9366

NOTE

Parts in Italics are non-stocked items and may need to be ordered.

PLEASE TURN TO THE NEXT PAGE

60 litre ChemeFlush Part No: L-H9351A

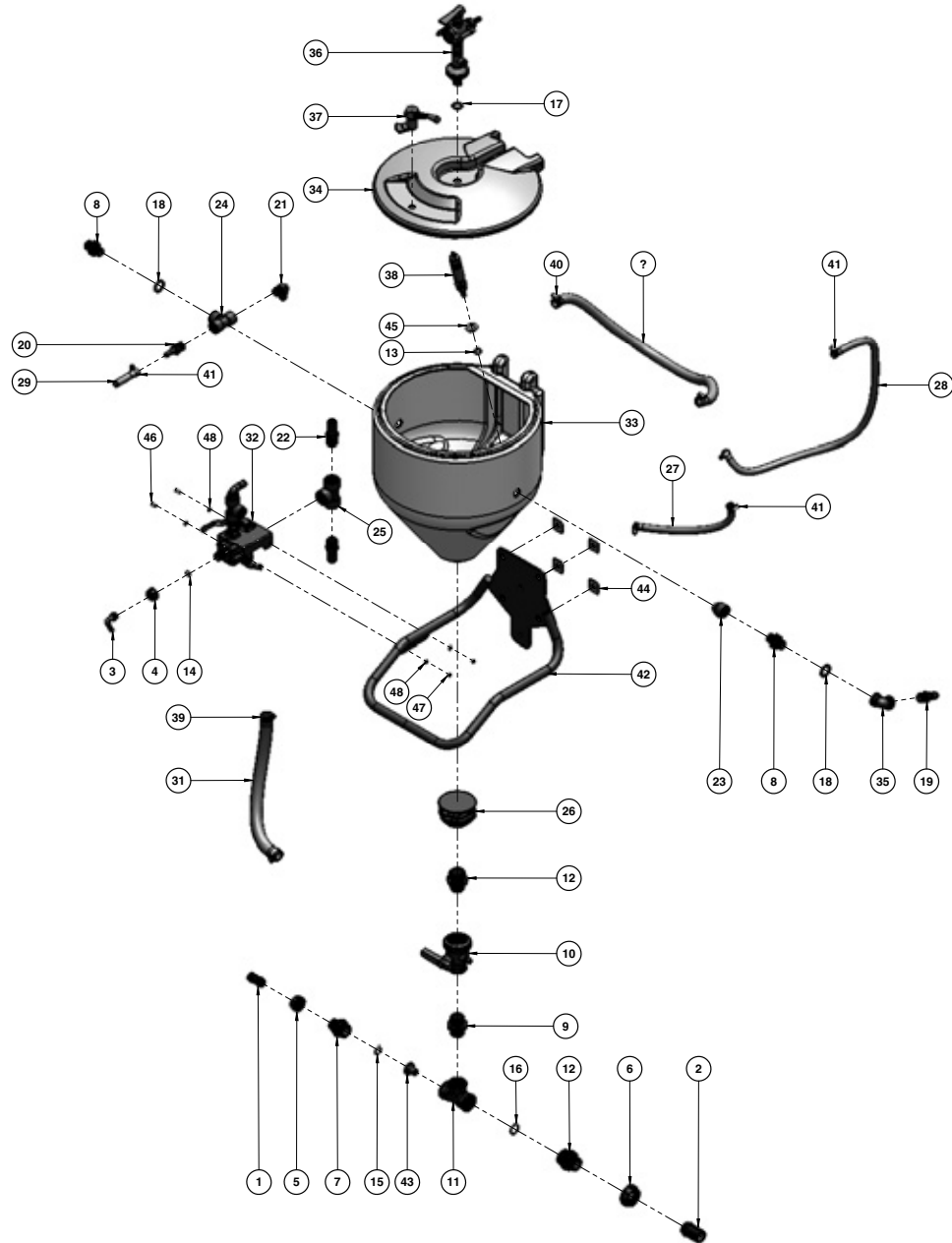

Drop Down Assembly Part No: L-H9355A

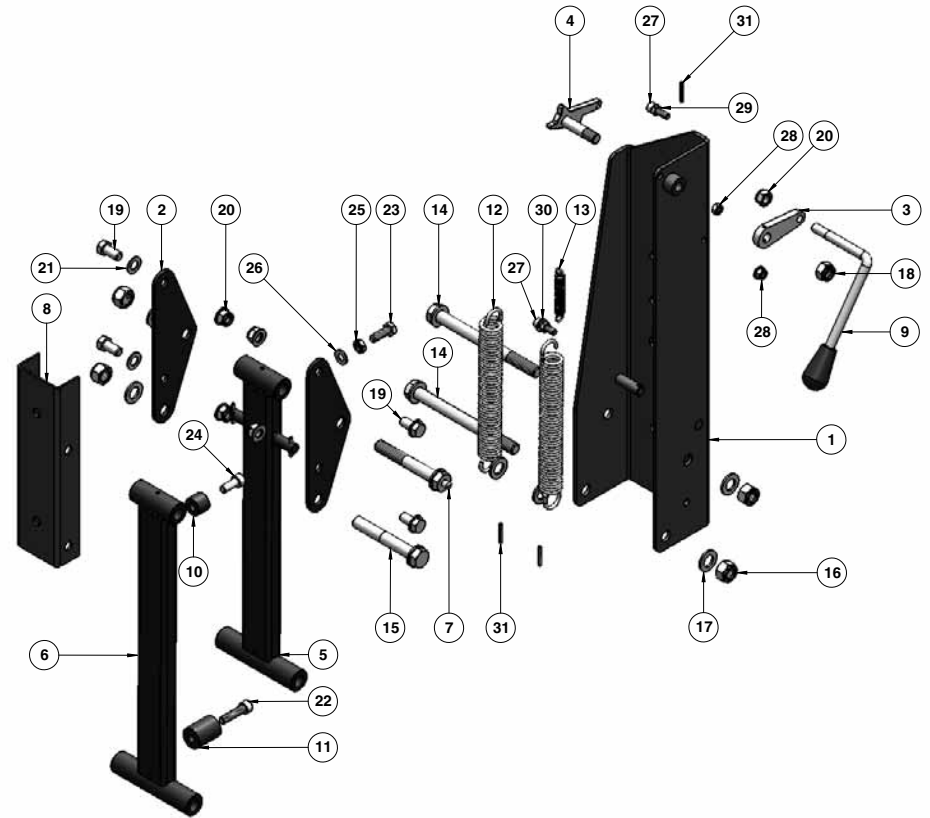

Section 7

Chem E Flush Assembly

Pos	Part No	Description	Qty
	L-H9351A	60 litre ChemeFlush	
1	A106425	TAIL 1" TO 25MM	1
2	A106640	TAIL 1 1/2" TO 40MM	1
3	A116313	ELBOW D13 FOR FLY NUT 3/4"	1
4	A200030	FLY NUT 3/4"	1
5	A200040	FLY NUT 1"	1
6	A200060	FLY NUT 1 1/2"	1
7	A240045	NIPPLE 1"-1 1/4" REDUCING	1
8	A250030	NIPPLE 3/4"	2
9	A250050	NIPPLE 1 1/4"	1
10	A454135	BALL VALVE POLY 1 1/4" 2 WAY	1
11	A1302050	TEE 1 1/4"	1
12	A2402065	REDUCER NIPPLE 1 1/2"-1 1/4"	2
13	AG4000B	FLAT SEAL 5/8" EPDM	1
14	AG10031	O RING 3/4"	1
15	AG10041	O RING 1"	1
16	AG10061	O RING 1 1/2"	1
17	AG40002	FLAT SEAL 1/2" EPDM	1
18	AG40003	FLAT SEAL 3/4" EPDM	2
19	BJHB075	HOSEBARB 3/4" NPT X 3/4" BARB	1
20	BJHB075-050	HOSEBARB 3/4" NPT X 1/2" BARB	1
21	BJHB075-90	ELBOW 3/4" NPT X 3/4" BARB	1
22	BJHB100	HOSEBARB 1"NPT X 1" BARB	2
23	BJSL075-90	ELBOW 3/4" MALE FEMALE	1
24	BJTEE075	TEE 3/4" FEMALE	1
25	BJTEE100	TEE FEMALE THREADED 1" NPT	1
26	BJTF150AV	ANTI VORTEX FITTING 1 1/2"	1
27	HPW12 12MM	HOSE	1
28	HPW12 12MM	HOSE	1
29	HPW12 12MM	HOSE	1
30	HPW20 20MM	HOSE	1
31	HPW25 25MM	HOSE	1
32	KB-1003A-1 60LT	CHEM-E-FLUSH MANIFOLD	1
33	P60C-1 60LT	CHEMIFLUSH TANK	1
34	P60C-2	LID	1
35	PH4622	ELBOW 3/4" FEMALE	1
36	POL6340839P.CRO	RINSING NOZZLE WITH 1/2" TAIL	1
37	POL63402999	LEVER HANDLE CHEM-E--FLUSH	1
38	POL63408499	RINSING NOZZLE	1
39	TR1HC	HOSE CLAMP 25MM 1" WORM DRIVE	2
40	TR34HC	HOSE CLAMP 20MM 3/4" WORM DRIVE	2

Pos	Part No	Description	Qty
41	TR12HC	HOSE CLAMP 20MM 1/2" WORM DRIVE	5
42	UP-105AB	CHEM-E-FLUSH MOUNTING BRKT SERIES 2	1
43	UP-116	NOZZLE 8.5 VENTURI CHEM E PLUS	1
44	40SQWASHER	40MM SQUARE WASHER	4
45	.75SSWASHER	3/4" STAINLESS STEEL WASHER	1
46	M6X16 M6 X 16	BOLT HT ZP	2
47	M6NNUT	M6 NYLOC NUT	2
48	M6FWASHER	M6 FLAT WASHER ZP	4
	L-H9355A	Drop Down Assembly	
1	L-H9355A-1	MAIN FRAME	1
2	L-H9355A-2	HINGE PLATE	2
3	L-H9355A-3	LEVER	1
4	L-H9355A-4	LOCK PLATE	1
5	L-H9355A-5	ARM, INNER	1
6	L-H9355A-6	ARM, OUTER	1
7	L-H9355A-7	LOCK PIN	1
8	L-H9355A-8	BOLTING CHANNEL	1
9	L-H9355A-9	LOCK HANDLE	1
10	L-H9355A-10	STOPPER, TOP	1
11	L-H9355A-11	STOPPER, BOTTOM	1
12	L-H9355A-12	SPRING 4.5 X 210 45 COILS	2
13	L-H9355A-13	SPRING 1.4 X 60 38 COILS	1
14	M16X180	M16 X 180 BOLT HT ZP	2
15	M16X110	M16 X 110 BOLT HT ZP	1
16	M16NNUT	M16 NYLOC NUT HT ZP	4
17	M16FWASHER	M16 FLAT WASHER ZP	10
18	M14NNUT	M14 NYLOC NUT HT ZP	1
19	M12X25	M12 X 25 SET SCREW HT ZP	4
20	M12NNUT	M12 NYLOC NUT HT ZP	5
21	M12FWASHER	M12 FLAT WASHER ZP	8
22	M10X40HEADSCREW	M10 X 40 ALLEN HEAD SCREW HT ZP	1
23	M10X30	M10 X 30 HEX HEAD BOLT HT ZP	1
24	M10X25HEADSCREW	M10 X 25 ALLEN HEAD SCREW HT ZP	1
25	M10HHNUT	M10 HEX HALF NUT HT ZP	1
26	M10FWASHER	M10 FLAT WASHER ZP	1
27	M8X25HEADSCREW	M8 X 25 ALLEN HEAD SCREW HT ZP	2
28	M8NNUT	M8 NYLOC NUT HT ZP	2
29	M8HHNUT	M8 HEX HALF NUT HT ZP	2
30	M8FWASHER	M8 FLAT WASHER ZP	2
31	ROLLPIN4	ROLL PIN DIAMETER 4	5



Suction Filter
(shown above on sprayer)

Suction Filter

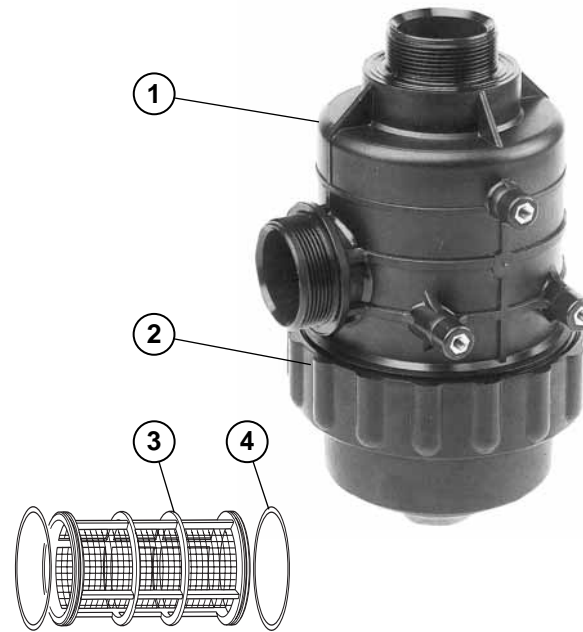

Pos	Part No	Description	Qty
1	A316 173	Filter Complete	1
2	A316000.050	Main Seal	1
3	A316003.030	Screen - internal	1
4	A316300.60	Screen O-Rings	2



Pressure Filter
(shown above on sprayer)

Pressure Filter

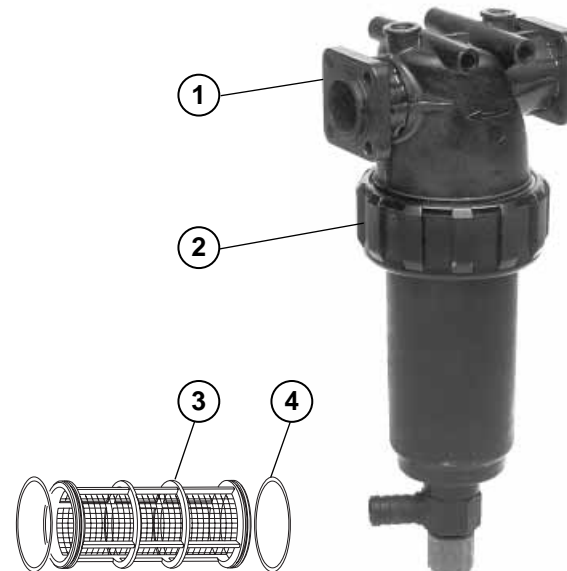

Pos	Part No	Description	Qty
1	A32621135	Filter Complete	1
2	AG10090	Main Seal	1
3	A3260035.030	Screen - internal	1
4	AG10052	Screen O-Rings	2



Lid on top of tank, basket inside.

Tank Lid & Basket

Tank Lid



Pos	Part No	Description	Qty
1	A356060	Lid Complete	1
2	A356660.02	Seal Ring	1

Basket

Part No: A300.0134

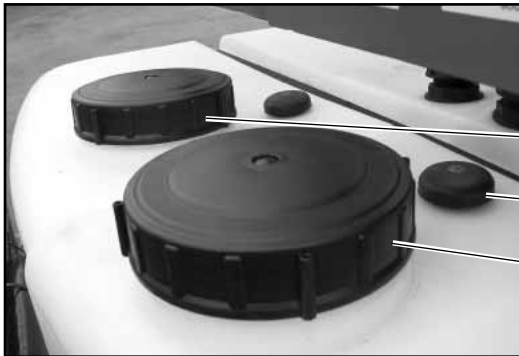

Foam & Rinse Tank Lids and Breathers

Foam & Rinse Tank Lids

Pos	Part No	Description	Qty
1	A354010	Foam Tank Lid	1
2	A354010	Water Tank Lid	1
3	A504203	Breather	1

Breather

Part No: A504 203



Tank Rinsing Jet & Agitator

Tank Rinse Jet

Pos	Part No	Description	Qty
1	POL63408399	Tank Rinsing Jet	1

Agitator

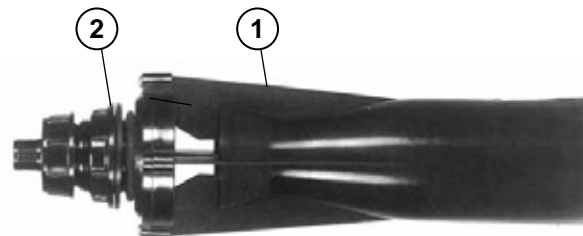

Pos	Part No	Description	Qty
1	A502163	Agitator Complete	1
2	A200050	Fly nut 1¼"	1

Foam Boot & Foam Tubing

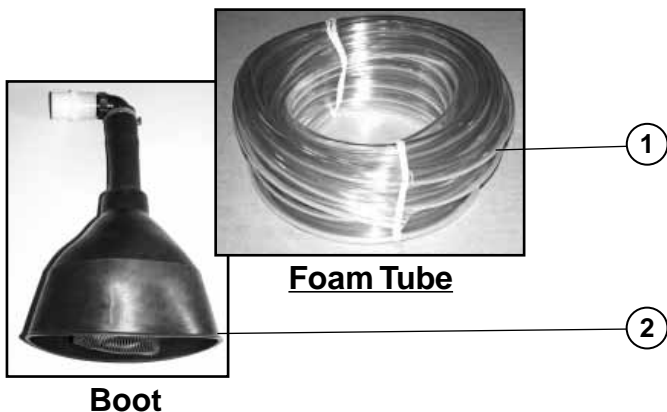

Foam Boot, Foam Tubing & Salamander Boost

Pos	Part No	Description	Qty
1	HCVT20	Foam Tube	20m
2	RHAA120	Foam Boot Complete	2
3	RHSJ000	Foam Bag	2

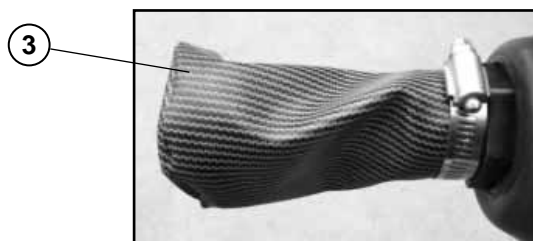

Foam Bag

Foam Tube Kits

Note: Standard length 20m coil,
see Part # 1 (at left)

In-Cab Control

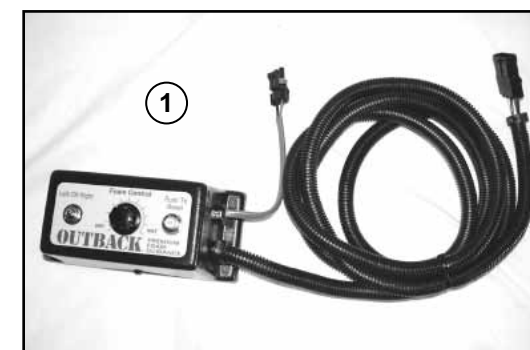

Pos	Part No	Description	Qty
1	RHAB371	In-Cab Control	1

Air Filter Location



Air Filter Cartridge

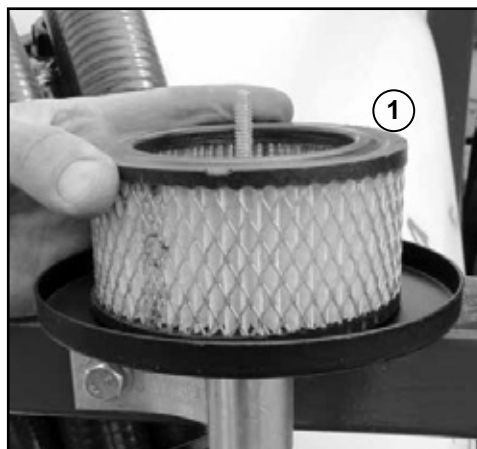

Pos	Part No	Description	Qty
1	RH69540	Air Filter Cartridge	1

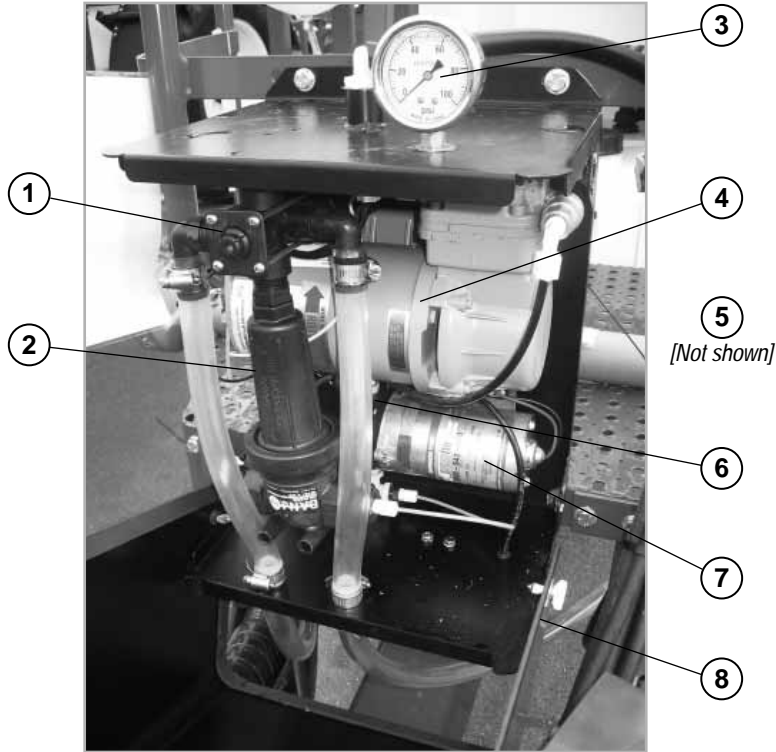

1 Directional Solenoid Valve
P/N: AA144P-1-3



2 Foam Chamber Assembly
P/N: LST075-HB



3 Gauge
P/N: RHGF60
(0-100 kpa)



4 AR Pump
P/N: RHFU001

5
[Not shown]

6

7

8



5 Cab Mounted Switch Box
P/N: RHAB371



6 Check Valve
P/N: RH69541



7 Liquid Pump Assembly
P/N: RHSU 005E
(Includes all fittings)



8 Liquid Filter
P/N: AAB122ML-12-P50

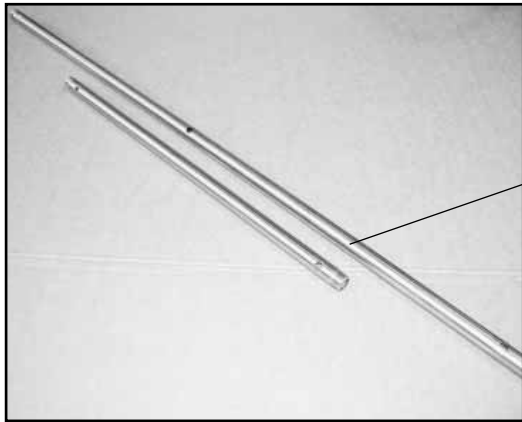

Boom Tube

①

② [not shown]

Boom Fittings

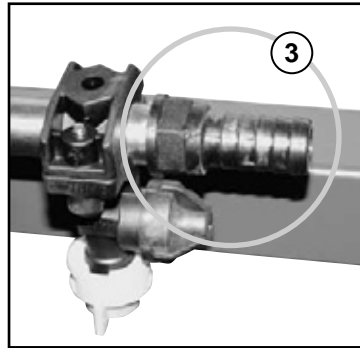

③

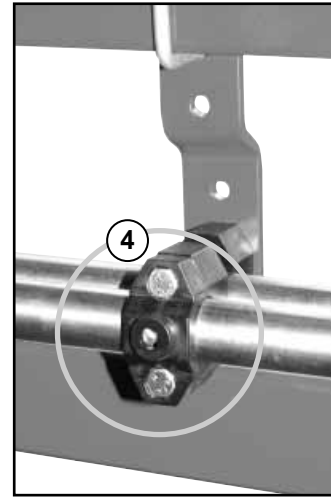

④

- 1 Boom Tube:
 - a) 2-hole Part No: GB550200500
 - b) 3-hole Part No: GB550300500
 - c) 4-hole Part No: GB550400500
 - d) 5-hole Part No: GB550500500
 - e) 6-hole Part No: GB550600500
 - f) 7-hole Part No: GB550700500
- 2 See page 7.11 Boom flush tap (not shown)
- 3 Hosetail Part No: A100219
- 4 Clamp Part No: A425130

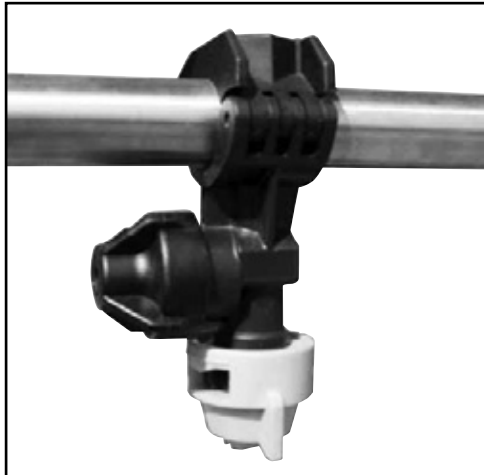

Single Non-Drip Nozzle Body

Single Nozzle Body



Part No: QJ17560A-½-NYB
(For Cap & Seal see next page)



Triplex Nozzle Body

Triplex Nozzle Complete

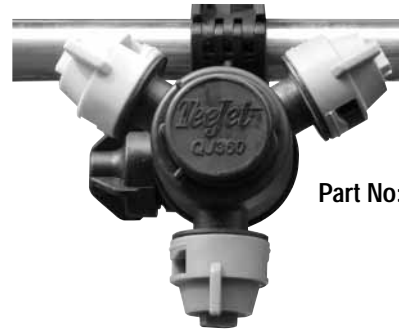

Part No: QJ363B-¼-NYB (does not include caps & seals)



Cap & Seal



Cap & Seal

- 1 Cap & Seal for XR Teejets
Part No: 25612-*3-NYR
- 2 Cap & Seal for AI Teejets
Part No: 25298-*3-NYR

* Colors of Quick TeeJet Caps

Colors of Quick TeeJet Caps	Color Code
Black	1
White	2
Red	3
Blue	4
Green	5
Yellow	6
Brown	7
Orange	8

Nozzle Jet Selection

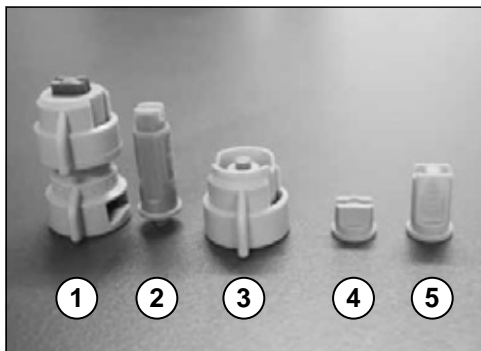

Pos	Part No	Description
1	TDCFFC1100* (*1.5, 2, 3, 4, 5)	Turbodrop Nozzle
2	AI1100* - VS (*1.5, 2, 3, 4, 5)	Teejet AI Nozzle
3	TCC1100* (*1.5, 2, 3, 4, 5)	Tip Cap (Ceramic)
4	XR1100*-VK (*1.5, 2, 3, 4, 5)	Standard Ceramic Teejet
5	TDAM - 1100* (*1.5, 2, 3, 4, 5)	Air Mix Nozzle

**(numbers in brackets denote code for size)*

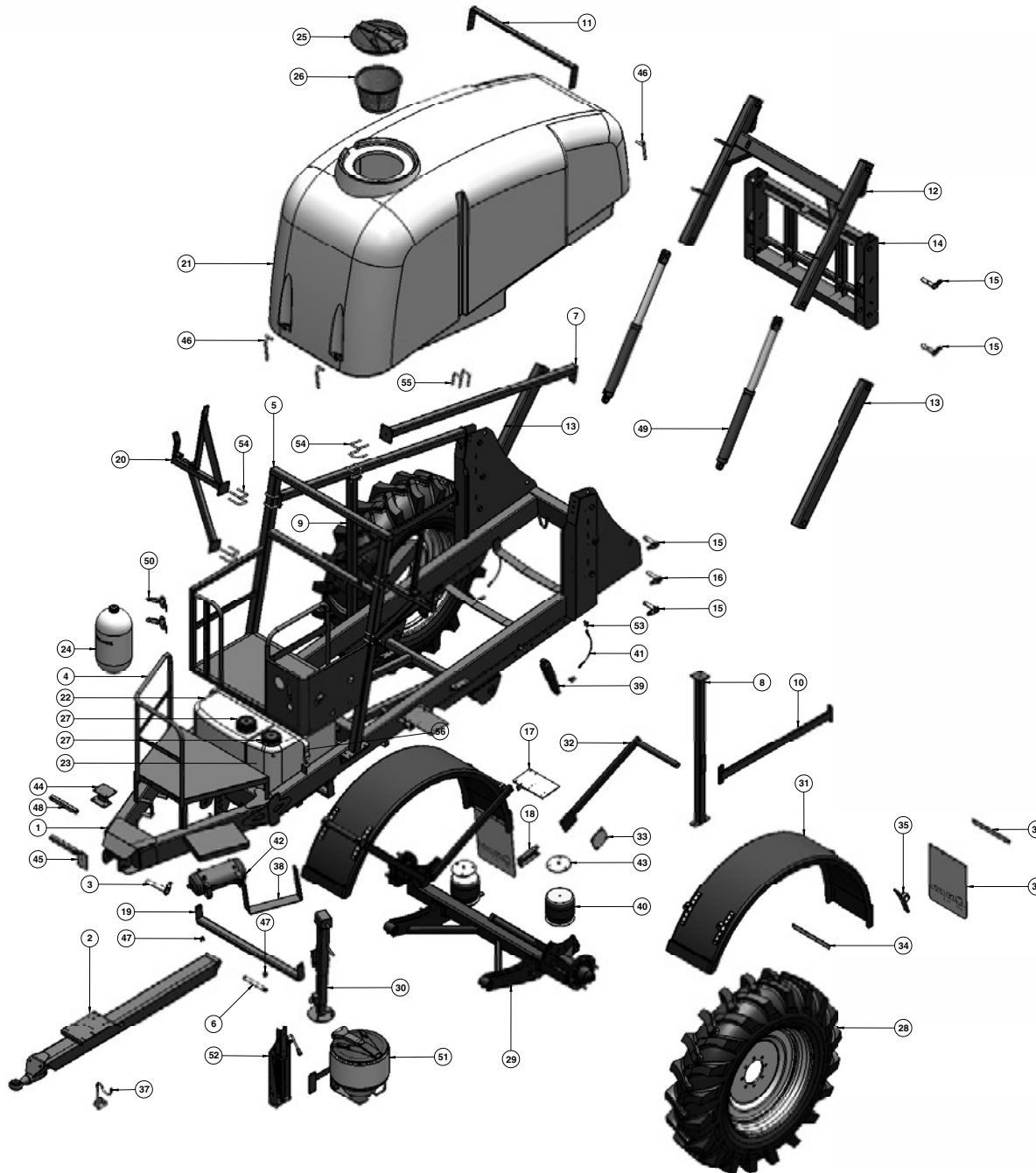

Section 7

Chassis, Tank & Wheels

Pos	Part No	Description	Qty
1	BP-700A	CHASSIS PEGASUS 4000/5000LT	1
	BP-700B	CHASSIS PEGASUS (6000LT only)	1
2	BP-700A-1	PEGASUS DRAWBAR 4000/5000LT	1
	BP-700B-1	PEGASUS DRAWBAR (6000LT only)	1
3	BP-700A-2A	DRAWBAR PIN 4000/5000LT HAYLITE	1
4	BP-700A-3	HANDRAIL LOWER PLATFORM PEGASUS	1
5	BP-700-3	MAIN PLATFORM ASSEMBLY 4000/5000LT	1
	BP-700B-3	MAIN PLATFORM ASSEMBLY (6000LT only)	1
6	BP-601-3	HITCH PIN PINTO & STALLION	1
7	BP-700A-4A	PLATFORM SUPPORT RAIL HAYLITE	2
	BP-700B-12LA	PLATFORM SUPPORT L.H. 6000LT HAYLITE (6000LT only)	1
	BP-700B-12RA	PLATFORM SUPPORT R.H. 6000LT HAYLITE (6000LT only)	1
8	BP-700A-5ALA	SUPPORT POST L.H. 5000LT HAYLITE	1
9	BP-700A-5ARA	SUPPORT POST R.H. 5000LT HAYLITE (5000LT only)	1
	BP-700A-5LA	SUPPORT POST L.H. 4000LT HAYLITE (4000LT only)	1
	BP-700A-5RA	SUPPORT POST R.H. 4000LT HAYLITE (4000LT only)	1
	BP-700B-5LA	SUPPORT POST L.H. 6000LT HAYLITE (6000LT only)	1
	BP-700B-5RA	SUPPORT POST R.H. 6000LT HAYLITE (6000LT only)	1
10	BP-700A-6A	SIDE SUPPORT RAIL 4000/5000LT HAYLITE	2
	BP-700B-4LA	SIDE RAIL L.H. PEGASUS 6000LT HAYLITE (6000LT only)	1
	BP-700B-4RA	SIDE RAIL R.H. PEGASUS 6000LT HAYLITE (6000LT only)	1
11	BP-700A-7A	UPPER SUPPORT BRACKET 4000/5000LT HAYLITE	1
12	BP-700-8A	UPPER PARALLELOGRAM ARM PEGASUS	1
13	BP-700-8B	LOWER PARALLELOGRAM ARM PEGASUS	2
14	BP-700-8C	REAR PARALLELOGRAM SECTION PEGASUS	1
15	BP-700-9AA	PIN 30MM X 155MM HAYLITE	8
16	BP-700-9BA	PIN 1" DIA X 155MM HAYLITE	2
17	BP-700-10	FILL PUMP MOUNT PLATE PEGASUS	1
18	BP-700-11	FILL FILTER MOUNT BRACKET PEGASUS	1
19	BP-700-12A	FLUSH TANK SUPPORT HAYLITE	2
20	BP-601-1A	BOOM PARKING BRACKET 21-28m	2
	BP-601-1BL	BOOM PARKING BRACKET 30m LH	1
	BP-601-1BR	BOOM PARKING BRACKET 30m LR	1
	BP-700-13AL	BOOM PARKING BRACKET 36m LH V2	1
	BP-700-13AR	BOOM PARKING BRACKET 36m LR V2	1
21	P5000-RAW	TANK POLY RAW PEGASUS 5000LT	1
	P4000A-RAW	TANK POLY RAW PEGASUS 4000LT (4000LT only)	1
	P6000-RAW	TANK POLY RAW PEGASUS (6000LT only)	1
22	P340-RAW	TANK POLY 340LT PEGASUS	1
23	P130-RAW	TANK POLY 130LT PEGASUS	1
24	P30	TANK POLY 30LT C/W LID & OUTLET	1

Pos	Part No	Description	Qty
	P30CAP	CAP 30LT FM TANK C/W O RING	1
25	A356060	LID HINGED 180 DEGREE 455MM	1
26	A300130	FILTER BASKET LARGE 254MM DEEP	1
27	A354010	LID 6" C/W SPRING BREATHER & OUTLET	2
28	BP-508A	TYRE & WHEEL ASSY 18.4 X 38" 14PLY	2
	BP-539	TYRE & WHEEL ASSY 20.8 X 42" (6000LT only)	2
29	BP-509E	AXLE AIR RIDE FIXED 8 STUD PEGASUS (4000LT/5000LT only)	1
	BP-509D	AXLE FIX SINGLE PEGASUS (4000LT only)	1
	BP-509G	AXLE SUSPENSION 10 STUD PEGASUS (5000LT/6000LT only)	1
	BP-509F	ADJUSTABLE AXLE 10 STUD AIR RIDE (6000LT only)	1
	BP-509H	ADJUSTABLE AXLE 8 STUD AIR RIDE (OPTION)	1
30	BP-525A	JACKING LEG PEGASUS	1
31	BP-526A	MUDGUARD POLY 1000MM RADIUS	2
	BP-526C	MUDGUARD POLY 1100MM RADIUS (OPTION)	2
32	BP-528B	BRACKET, MUDGUARD PEGASUS TO SUIT BP-526A	4
	BP-528B-1	BRACKET MUDGUARD PEGASUS TO SUIT BP-526C (6000LT only)	4
33	BP-528D	MUDGUARD BRACKET SPACER (6000LT only)	4
34	BP-180	MUDFLAP PLATE	4
35	BP-531A	MUDGUARD MOUNTING BRACKET	8
36	BP-542	MUDFLAP WHITE	2
37	BP-548	PTO HOLDER PEGASUS	1
38	BP-601-4A	BOLT ON STEP HAYLITE	1
39	BP-607	SHOCK ABSORBER AIR RIDE P126	2
40	BP-608B	AIRBAG SPRING S-21208	2
41	BP-617A	LIMIT ROPE 6.3MM X 420LG	2
42	BP-620A	AIR TANK HK JADE	1
43	BP-628	ADAPTOR PLATE AIRBAG	2
44	BP-629	COMPRESSOR MOUNTING BRACKET PEGASUS	1
45	BP-631	ENVIRODRUM PLATE	1
46	BP-701	TIE DOWN BRACKET PEGASUS	4
	BP-701B	TIE DOWN BRACKET PEGASUS (6000LT only)	4
47	B0006	BARE LINCH PIN 7/16" DIAMETER	2
48	FM-404	FOAM MARKER SPACER	2
49	HP-019B	PTE HYDRAULIC DISPLACEMENT CYLINDER 3.0 X 20	2
50	LP-132A	TANK BRACKET 30LT BOTTLE VERSION 2	2
51	L-H9351A	CHEMICAL MIXING UNIT MK2	1
52	L-H9355A	DROPDOWN MOUNTING BRACKET VERSION 2	1
53	MP-564	DEE SHACKLE SIZE 10	4
54	XBMBB75	U-BOLT 75MM X 10	12
55	XBMBB65	U-BOLT 65MM X 10	4
56	XSTRAP1475	TANK STRAP 1475MM	1

PART NO: BP-509D PEGASUS 4000/5000L FIXED AXLE 8 STUD

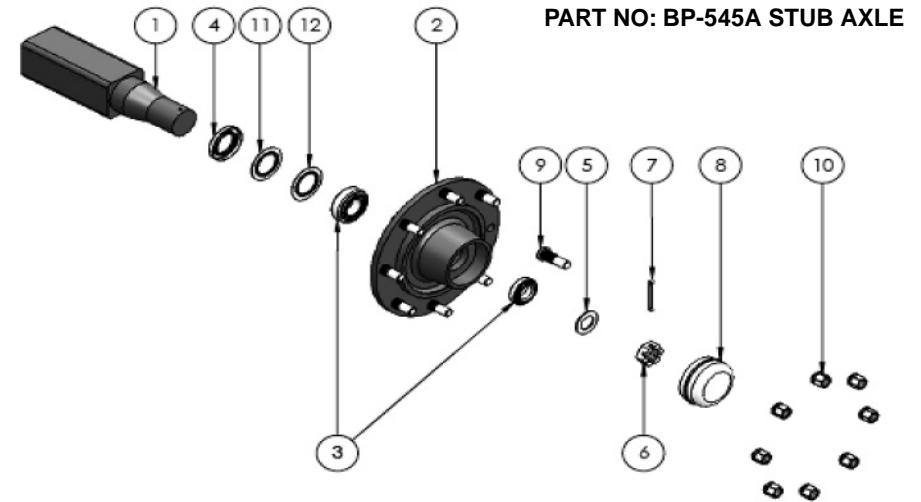
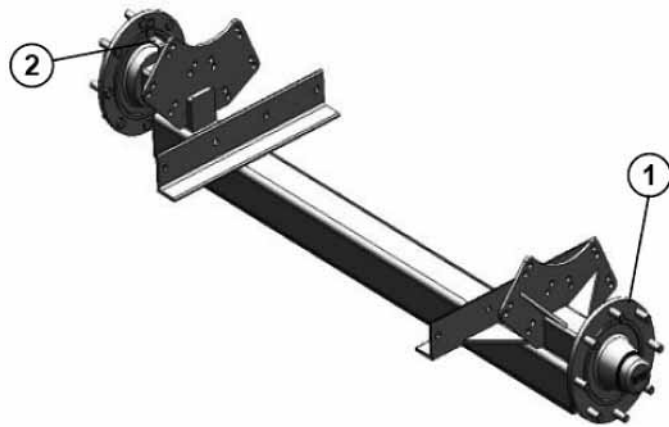

Pos	Part No	Description	Qty
1	BP-545A	STUB AXLE 90mm 8/275 PCD	2
2	MT10013	SPEED SENSOR MOUNTING BRACKET	1

Pos	Part No	Description	Qty
1	BP-532-1	STUB AXLE 90SQ x 538 LONG	
2	BP-545A-2	WHEELHUB 8/275 PCD	
3	BP-532-3	BEARING KIT 30311/32216	
4	BP-532-4	TRIPLE LIP SEAL 140 x 100 x 12mm	
5	BP-532-5	WASHER 1 3/4" GR.8	
6	BP-532-6	SLOTTED/CASTLE NUT M45 x 2	
7	BP-532-7	SPLIT PIN 80 x 8MM	
8	BP-532-8	DUST CAP 120mm (4 screws needed items 13 & 14)	
9	HP-199F-7	WHEEL STUD M18 x 1.5 x 65	
10	HP-199F-8	WHEEL NUT M18 x 1.5	
11	BP-532-11	SEAL RING 100.5 x 82 x 16mm	
12	BP-532-12	WEAR RING (to suit triple lip seal)	
13	BP-532-13	SOCKET HEAD CAP SCREW M6 x 20 (not shown)	
14	BP-532-14	M6 RIB LOCK WASHER (not shown)	

NOTE

Drawing are for illustration purposes only.
Please refer to the parts list.

PART NO: BP-509E PEGASUS 4000/5000L AIRRIDE FIXED AXLE 8 STUD

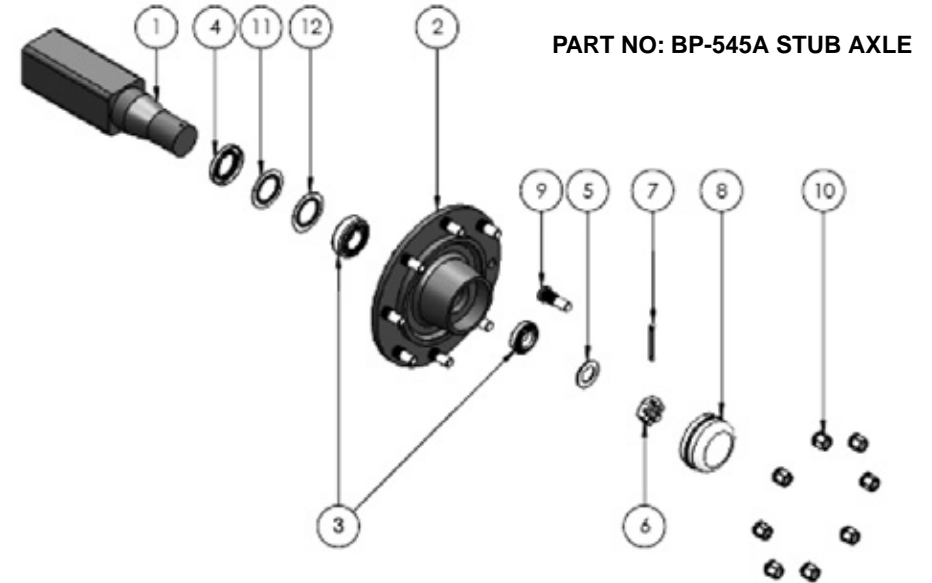
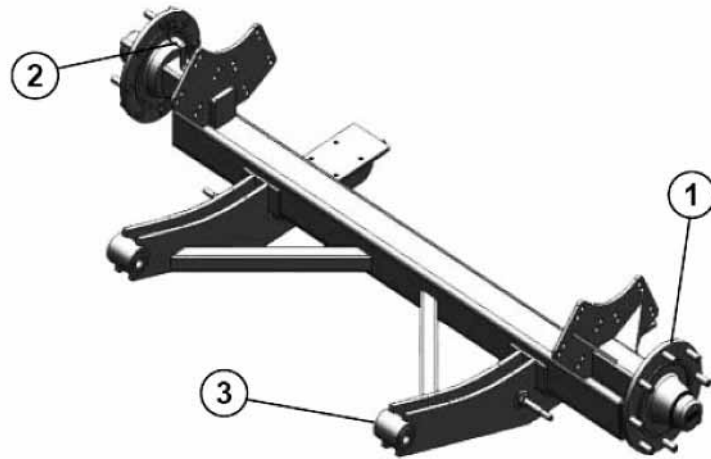

Pos	Part No	Description	Qty
1	BP-545A	STUB AXLE 90mm 8/275 PCD	2
2	MT10013	SPEED SENSOR MOUNTING BRACKET	1
3	BP-809-4	FLEXIBLE BUSH AIRRIDE SUSPENSION	2
4	WT1234	AIRRIDE AXLE BOLT M30 x 190 <i>(not shown)</i>	2
5	WT1235NL	AIRRIDE AXLE NYLO NUT M30 <i>(not shown)</i>	2

Pos	Part No	Description	Qty
1	BP-532-1	STUB AXLE 90SQ x 538 LONG	
2	BP-545A-2	WHEELHUB 8/275 PCD	
3	BP-532-3	BEARING KIT 30311/32216	
4	BP-532-4	TRIPLE LIP SEAL 140 x 100 x 12mm	
5	BP-532-5	WASHER 1 3/4" GR.8	
6	BP-532-6	SLOTTED/CASTLE NUT M45 x 2	
7	BP-532-7	SPLIT PIN 80 x 8MM	
8	BP-532-8	DUST CAP 120mm <i>(4 screws needed items 13 & 14)</i>	
9	HP-199F-7	WHEEL STUD M18 x 1.5 x 65	
10	HP-199F-8	WHEEL NUT M18 x 1.5	
11	BP-532-11	SEAL RING 100.5 x 82 x 16mm	
12	BP-532-12	WEAR RING <i>(to suit triple lip seal)</i>	
13	BP-532-13	SOCKET HEAD CAP SCREW M6 x 20 <i>(not shown)</i>	
14	BP-532-14	M6 RIB LOCK WASHER <i>(not shown)</i>	

NOTE

*Drawing are for illustration purposes only.
Please refer to the parts list.*

PART NO: BP-509F PEGASUS 6000L AJUSTABLE AIRRIDE AXLE 10 STUD

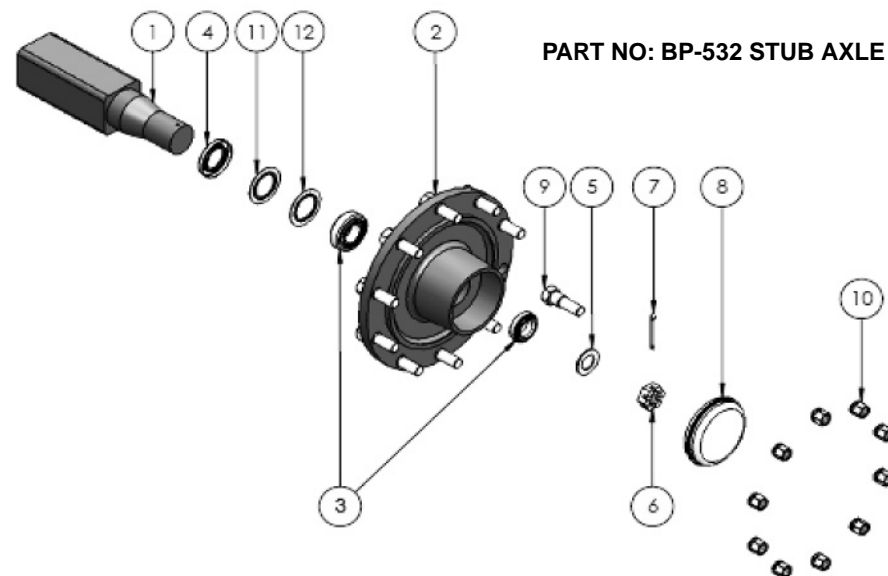
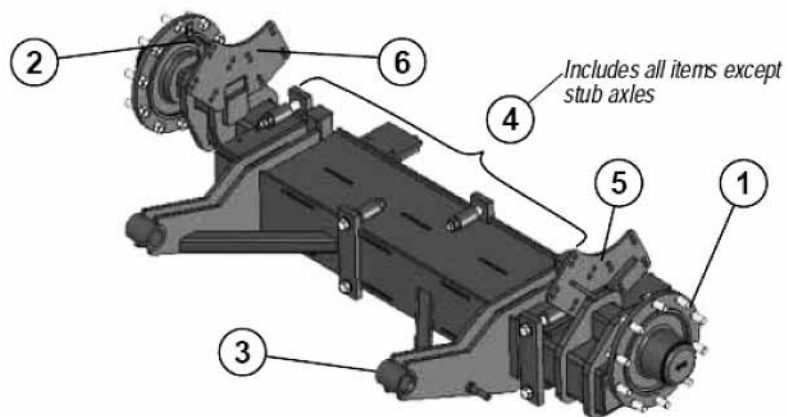

Pos	Part No	Description	Qty
1	BP-532	STUB AXLE 90SQ 10/335PCD	2
2	MT10013	SPEED SENSOR MOUNTING BRACKET	1
3	BP-809-4	FLEXIBLE BUSH AIRRIDE SUSPENSION	2
4	BP-509F-2	AXLE HOUSING & TRAILING ARM ASSEMBLY	1
5	BP-509F-3L	AXLE BP-509F 10 STUD LH	1
6	BP-509F-3R	AXLE BP-509F 10 STUD RH	1
7	WT1234	AIRRIDE AXLE BOLT M30 x 190 (not shown)	2
8	WT1235NL	AIRRIDE AXLE NYLOC NUT M30 (not shown)	2

Pos	Part No	Description	Qty
1	BP-532-1A	STUB AXLE 90SQ x 390 LONG	
2	BP-532-2	WHEELHUB 10/335 PCD	
3	BP-532-3	BEARING KIT 30311/32216	
4	BP-532-4	TRIPLE LIP SEAL 140 x 100 x 12mm	
5	BP-532-5	WASHER 1 3/4" GR.8	
6	BP-532-6	SLOTTED/CASTLE NUT M45 x 2	
7	BP-532-7	SPLIT PIN 80 x 8MM	
8	BP-532-8	DUST CAP 120mm (4 screws items 13 & 14)	
9	BP-532-9	WHEEL STUD M22 x 1.5 x 85	
10	BP-532-10	WHEEL NUT M22 x 1.5	
11	BP-532-11	SEAL RING 100.5 x 82 x 16mm	
12	BP-532-12	WEAR RING (to suit triple lip seal)	
13	BP-532-13	SOCKET HEAD CAP SCREW M6 x 20 (not shown)	
14	BP-532-14	M6 RIB LOCK WASHER (not shown)	

NOTE

Drawing are for illustration purposes only.
Please refer to the parts list.

PART NO: BP-509G PEGASUS 6000L AIRRIDE FIXED AXLE 10 STUD

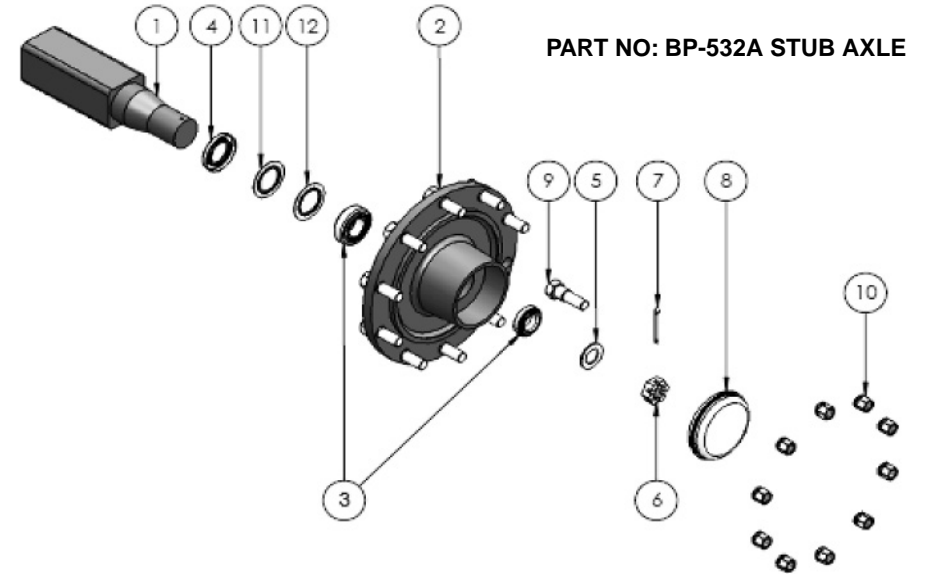
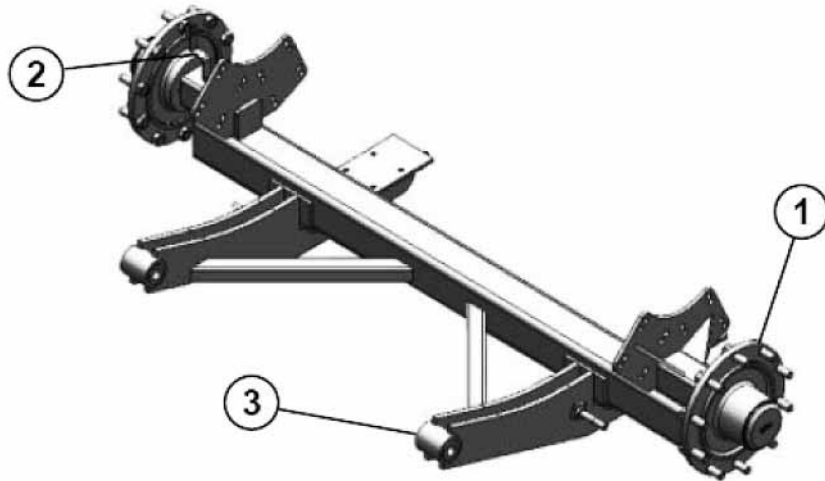

Pos	Part No	Description	Qty
1	BP-532A	STUB AXLE 90mm 10/335PCD 538LG	2
2	MT10013	SPEED SENSOR MOUNTING BRACKET	1
3	BP-809-4	FLEXIBLE BUSH AIRRIDE SUSPENSION	2
4	WT1234	AIRRIDE AXLE BOLT M30 x 190 <i>(not shown)</i>	2
5	WT1235NL	AIRRIDE AXLE NYLOC NUT M30 <i>(not shown)</i>	2

Pos	Part No	Description	Qty
1	BP-532-1	STUB AXLE 90SQ x 538 LONG	
2	BP-532-2	WHEELHUB 10/335 PCD	
3	BP-532-3	BEARING Kit 30311/32216	
4	BP-532-4	TRIPLE LIP SEAL 140 x 100 x 12mm	
5	BP-532-5	WASHER 1 3/4" GR.8	
6	BP-532-6	SLOTTED/CASTLE NUT M45 x 2	
7	BP-532-7	SPLIT PIN 80 x 8MM	
8	BP-532-8	DUST CAP 120mm <i>(4 screws items 13 & 14)</i>	
9	BP-532-9	WHEEL STUD M22 x 1.5 x 85	
10	BP-532-10	WHEEL NUT M22 x 1.5	
11	BP-532-11	SEAL RING 100.5 x 82 x 16mm	
12	BP-532-12	WEAR RING <i>(to suit triple lip seal)</i>	
13	BP-532-13	SOCKET HEAD CAP SCREW M6 x 20 <i>(not shown)</i>	
14	BP-532-14	M6 RIB LOCK WASHER <i>(not shown)</i>	

NOTE

*Drawing are for illustration purposes only.
Please refer to the parts list.*

PART NO: BP-509H PEGASUS 4000/5000L AJUSTABLE AIRRIDE AXLE 8 STUD

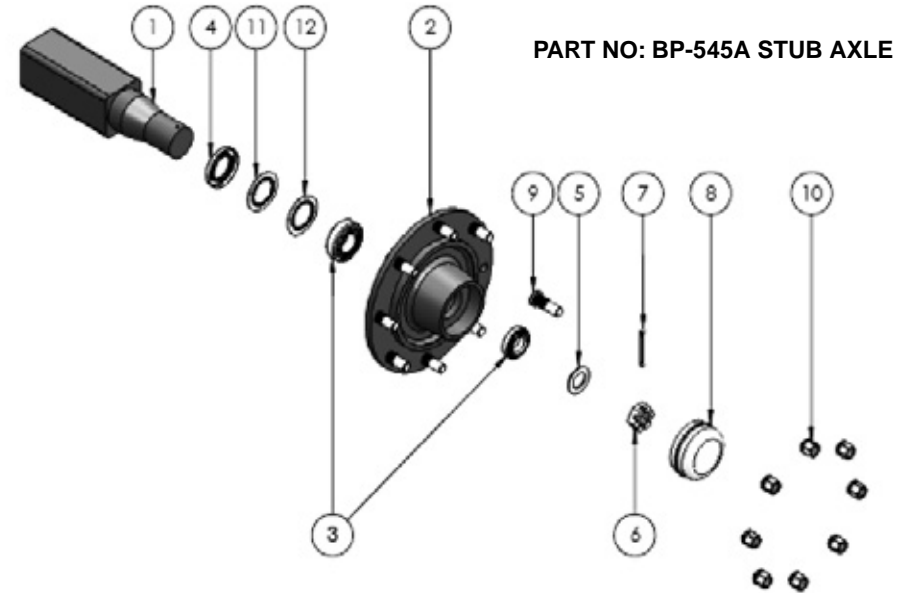
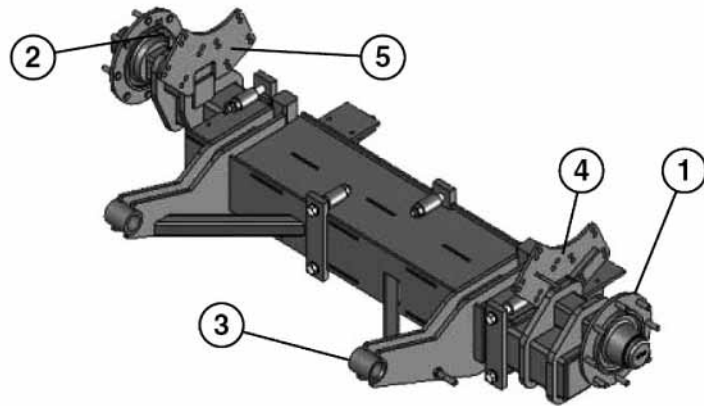

Pos	Part No	Description	Qty
1	BP-545A	STUB AXLE 90mm 8/275 PCD	2
2	MT10013	SPEED SENSOR MOUNTING BRACKET	1
3	BP-809-4	FLEXIBLE BUSH AIRRIDE SUSPENSION	2
4	BP-509H-3L	AXLE BP-509F 10 STUD LH	1
5	BP-509H-3R	AXLE BP-509F 10 STUD RH	1
6	WT1234	AIRRIDE AXLE BOLT M30 x 190 <i>(not shown)</i>	2
7	WT1235NL	AIRRIDE AXLE NYLOC NUT M30 <i>(not shown)</i>	2

Pos	Part No	Description	Qty
1	BP-532-1	STUB AXLE 90SQ x 538 LONG	
2	BP-545A-2	WHEELHUB 8/275 PCD	
3	BP-532-3	BEARING KIT 30311/32216	
4	BP-532-4	TRIPLE LIP SEAL 140 x 100 x 12mm	
5	BP-532-5	WASHER 1 3/4" GR.8	
6	BP-532-6	SLOTTED/CASTLE NUT M45 x 2	
7	BP-532-7	SPLIT PIN 80 x 8MM	
8	BP-532-8	DUST CAP 120mm <i>(4 screws needed items 13 & 14)</i>	
9	HP-199F-7	WHEEL STUD M18 x 1.5 x 65	
10	HP-199F-8	WHEEL NUT M18 x 1.5	
11	BP-532-11	SEAL RING 100.5 x 82 x 16mm	
12	BP-532-12	WEAR RING <i>(to suit triple lip seal)</i>	
13	BP-532-13	SOCKET HEAD CAP SCREW M6 x 20 <i>(not shown)</i>	
14	BP-532-14	M6 RIB LOCK WASHER <i>(not shown)</i>	

NOTE

*Drawing are for illustration purposes only.
Please refer to the parts list.*



Compressor

Compressor

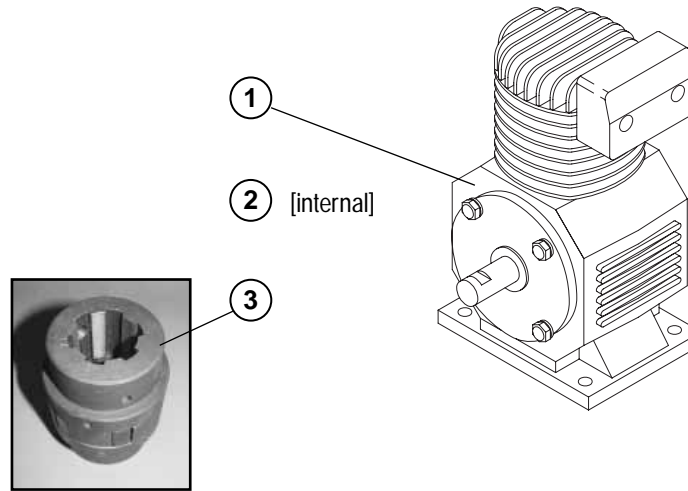

Pos	Part No	Description	Qty
1	BP-625	Compressor Complete	1
2	BP-625KIT	Kit	1
3	BP-624	Coupler	1



Air Tank

Air Tank

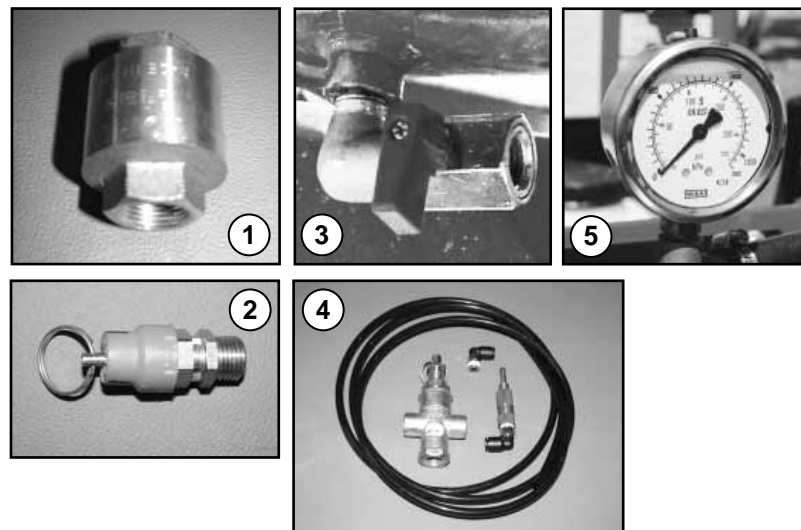

Pos	Part No	Description	Qty
1	FM-NRV	Non-return Valve	1
2	BP-622	Air Relief Valve Ass	1
3	BALL14MF2M	Exhaust/drain tap	1
	TFEL144MF	Brass Elbow	1
4	BP-627	Pilot Operated Relief Assembly	1
5	L-G1420	Gauge	1

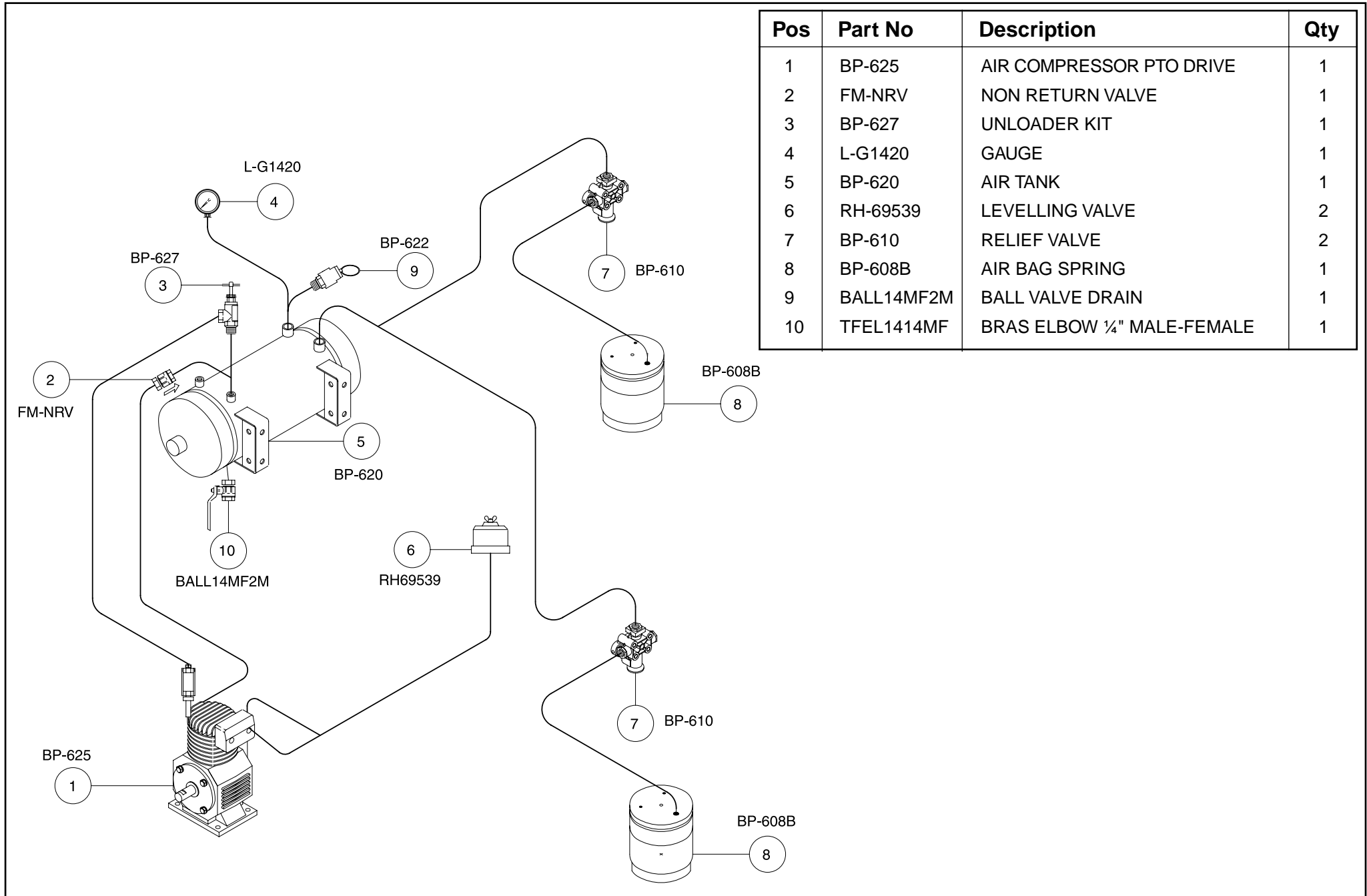

MT9000 / 3 PIN BALL VALVES WIRING CONFIGURATION FOR 24 PIN MT9000 BULKHEAD LOOM

4/12/2003
ALL WIRE 3mm
USO

CONSOLE CONNECTION	CONSOLE PIN ID	MT90LOOM/2 WIRE COLOUR	24 PIN CONNECTOR	24 PIN WIRE COLOUR	APPLIANCE	M.T. WIRE COLOUR	MT90LOOM/1 WIRE COLOUR	MT90LOOM/1 REAR CONNECTOR	ID COLOUR	CONNECTOR ID	MT90LOOM/3 REAR CONNECTOR	ID COLOUR
3 PIN	A	YELLOW 2.5mm	21	YELLOW 2.5mm	SPEED	RED	YELLOW 2.5mm	3 PIN	YELLOW	A	pulse	
3 PIN	B	GREEN 2.5mm	2	GREEN 2.5mm	SPEED	WHITE	GREEN 2.5mm	3 PIN	YELLOW	B	12v+	
3 PIN	C	BLUE 2.5mm	11	BLUE 2.5mm	SPEED	BLACK	BLUE 2.5mm	3 PIN	YELLOW	C	12v-	
10 PIN	A	GREEN/PURPLE	18	GREEN/PURPLE	FLOW	BROWN	GREEN/PURPLE	3 PIN	GREEN	A	pulse	
10 PIN	B	RED 2.5mm	16	RED 2.5mm	FLOW	RED	(RED)BLUE/BLACK	3 PIN	GREEN	B	12v+	RED NOT CONTD
10 PIN	C	ORANGE	9	ORANGE	FLOW	ORANGE	ORANGE	3 PIN	GREEN	C	12v-	
10 PIN	D	GREY	1	GREY	SERVO	YELLOW	GREY	mPm PLUG	GREY	1		
10 PIN	E	VIOLET	3	VIOLET	SERVO	GREEN	VIOLET	mPm PLUG	GREY	2		
10 PIN	F	BLUE/WHITE	5	BLUE/WHITE	BOOM 6	BLUE	BLUE/WHITE	10 PIN		H	mPm PLUG	BLUE #6
10 PIN	G	BROWN/YELLOW	19	BROWN/YELLOW	RELIEF	VIOLET	BROWN/YELLOW	4 PIN M	NOT CONNECTED	A	FILL FLOW	BROWN +
10 PIN	H	BLACK 2.5mm	4	BLACK 2.5mm	HOLD	GREY	BLACK	4 PIN M	NOT CONNECTED	B	FILL FLOW	BLUE -
10 PIN	J	BLUE/BLACK	13	BLUE/BLACK	PSI	WHITE	BLUE/BLACK	4 PIN M	NOT CONNECTED	C	FENCELINE	R H
10 PIN	K	BLACK/RED	8	BLACK/RED	PSI	BLACK	BLACK/RED	4 PIN M	NOT CONNECTED	D	FENCELINE	L H
7 PIN	A	WHITE 2.5mm	20	WHITE 2.5mm	BOOM 1	YELLOW	WHITE 2.5mm	10 PIN		A	mPm PLUG	YELLOW #1
7 PIN	B	ORANGE/BLUE	7	ORANGE/BLUE	BOOM 2	BROWN	ORANGE/BLUE	10 PIN		B	mPm PLUG	BROWN #2
7 PIN	C	BLUE/YELLOW	17	BLUE/YELLOW	BOOM 3	GREY	BLUE/YELLOW	10 PIN		C	mPm PLUG	GREY #3
7 PIN	D	PINK	14	PINK	BOOM 4	BLACK	PINK	10 PIN		D	mPm PLUG	BLACK #4
7 PIN	E	RED 6mm	12	ORANGE 4mm (10a FUSE)	POWER +ve	ORANGE	RED 4mm	10 PIN		F	mPm PLUG #1	
7 PIN	F	BROWN 2.5mm	10	BROWN 2.5mm	BOOM 5	RED	BROWN 2.5mm	10 PIN		E	mPm PLUG	RED #5
7 PIN	G	BLACK 6mm	24	GREEN 4mm	POWER -ve	BLUE	BLACK 4mm	10 PIN		G	mPm PLUG #2	
				To MT90LOOM/6 Relay		25	BLUE/BLACK	10 PIN		J		
				To MT90LOOM/6 Relay		26	BLACK/RED	10 PIN		K		
				From MT90LOOM/6 Relay		25	BLUE/BLACK	mPm PLUG	BLUE	2		
				From MT90LOOM/6 Relay		26	BLACK/RED	mPm PLUG	BLUE	1		
4 PIN	A	RED 4mm	22	RED 4mm	FOAM MARKER	WHITE	RED 4mm	4 PIN FM		A		
4 PIN	B	BLACK 4mm	15	BLACK 4mm	FOAM MARKER	RED	BLACK 4mm	4 PIN FM		B		
4 PIN	C	BLUE 4mm	6	BLUE 4mm	FOAM MARKER	GREEN	BLUE 4mm	4 PIN FM		C		
4 PIN	D	WHITE 4mm	23	WHITE 4mm	FOAM MARKER	BLACK	WHITE 4mm	4 PIN FM		D		



MT90LOOM/1

Main loom from rear of tractor to the sprayer, connects to control valves, foam marker etc & connects to MT90LOOM/2, MT90LOOM/3 & MT90LOOM/6.



MT90LOOM/2

Main loom from Spray controller to the rear of the cab. Carries plugs to connect controller & foam marker. Connects to MT90LOOM/1.

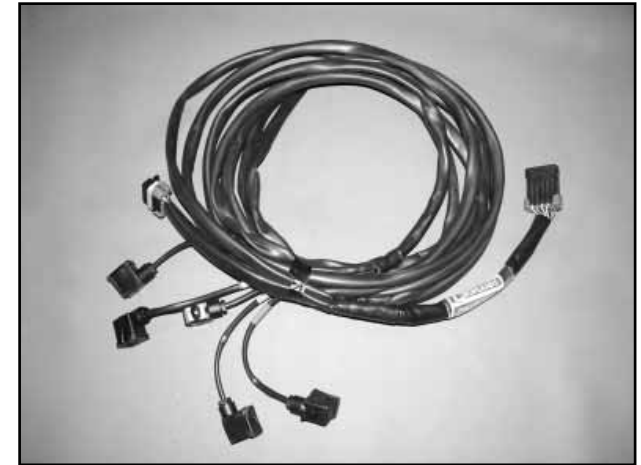

MT90LOOM/3

Extension loom that runs from front of sprayer, connected to MT90LOOM/1 to boom section control valves at rear of sprayer.



MT90LOOM/6

Relay box fitted on front of chassis under the working platform. Operates Dump valve from Controller.

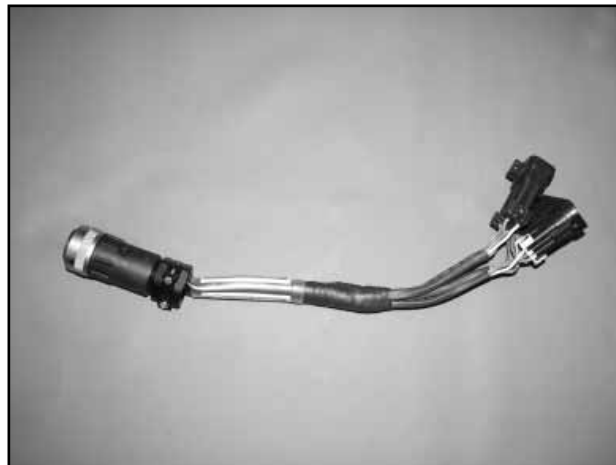

MT90LOOM/854

Conversion connector to allow MT90LOOM/2 to connect to the Teejet 854 Controller.

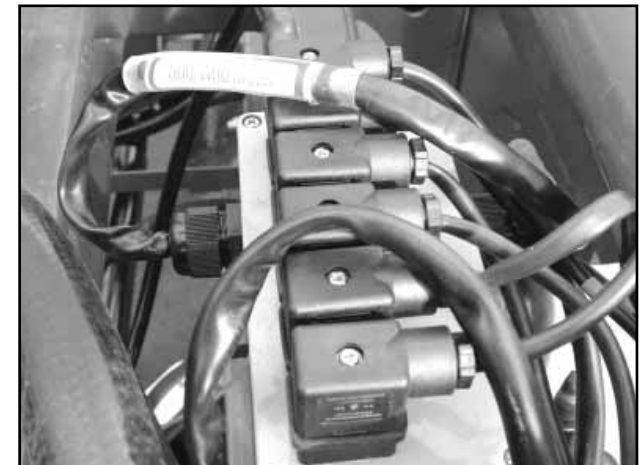

MT90LOOM/DUAL

Relay box fitted to rear of sprayer, located on the centre section. Only used if dual lines are fitted. Allows all valves to be operated correctly.

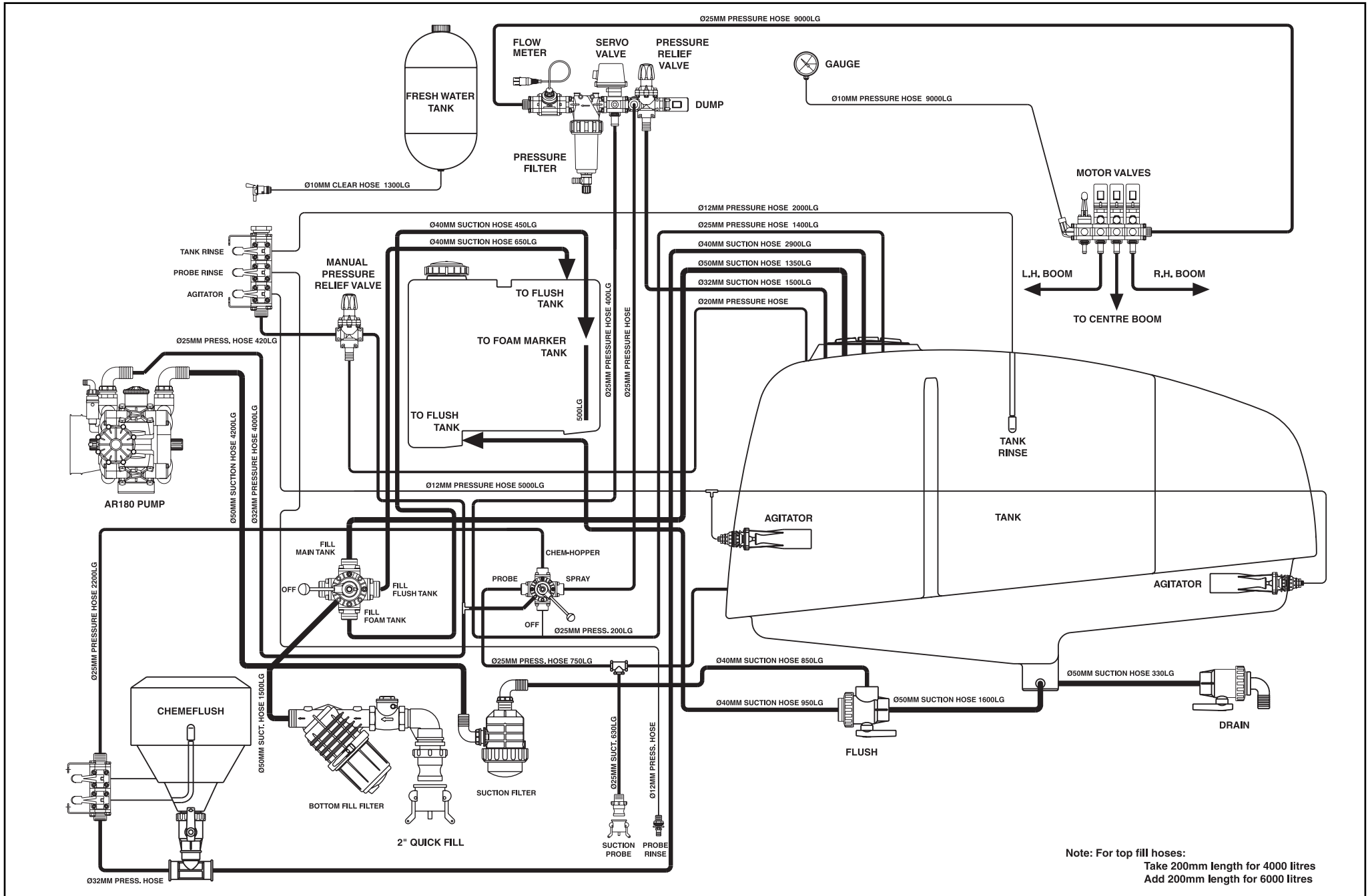

Note: For top fill hoses:
 Take 200mm length for 4000 litres
 Add 200mm length for 6000 litres

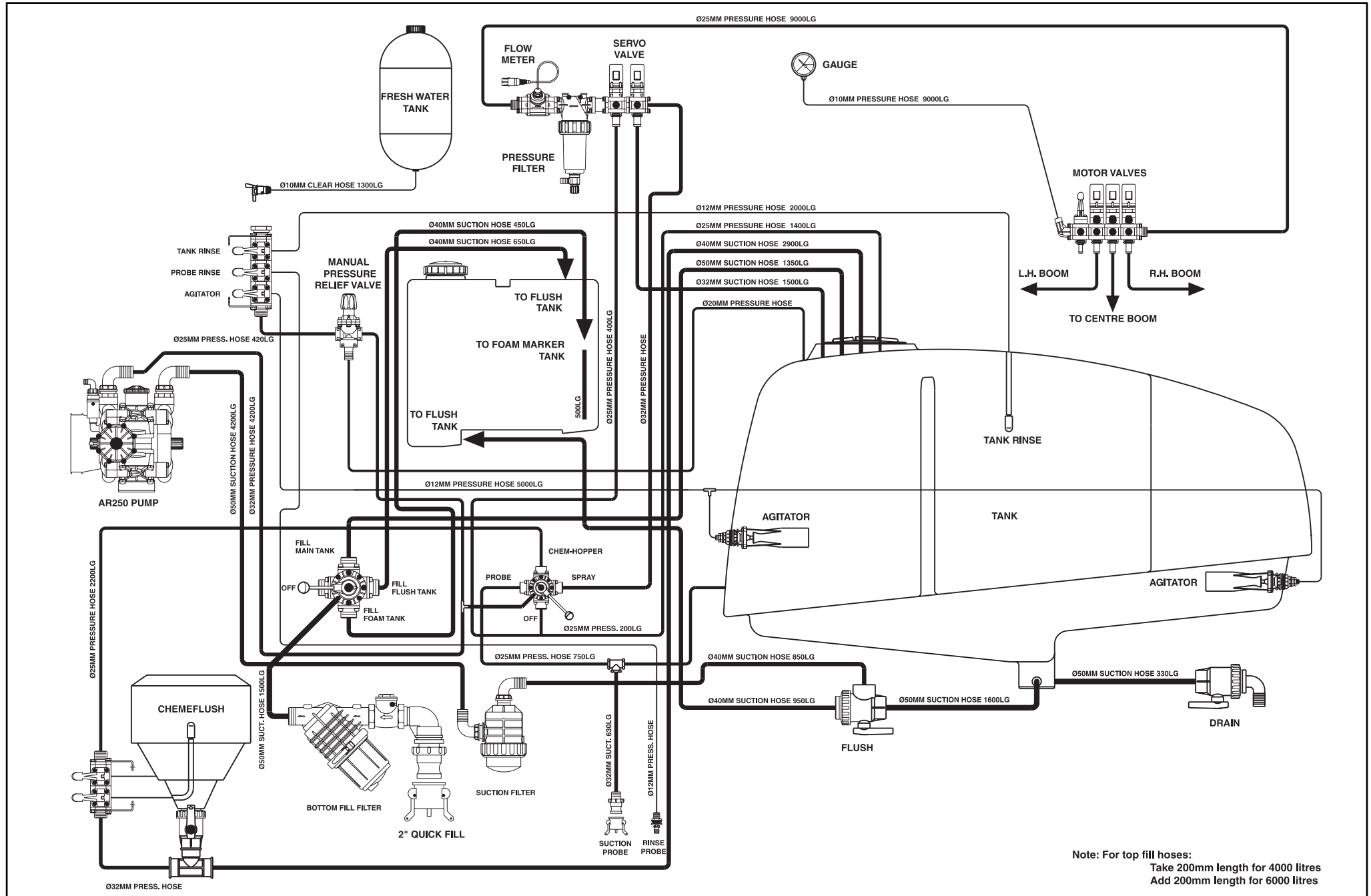

Note: For top fill hoses:
 Take 200mm length for 4000 litres
 Add 200mm length for 6000 litres

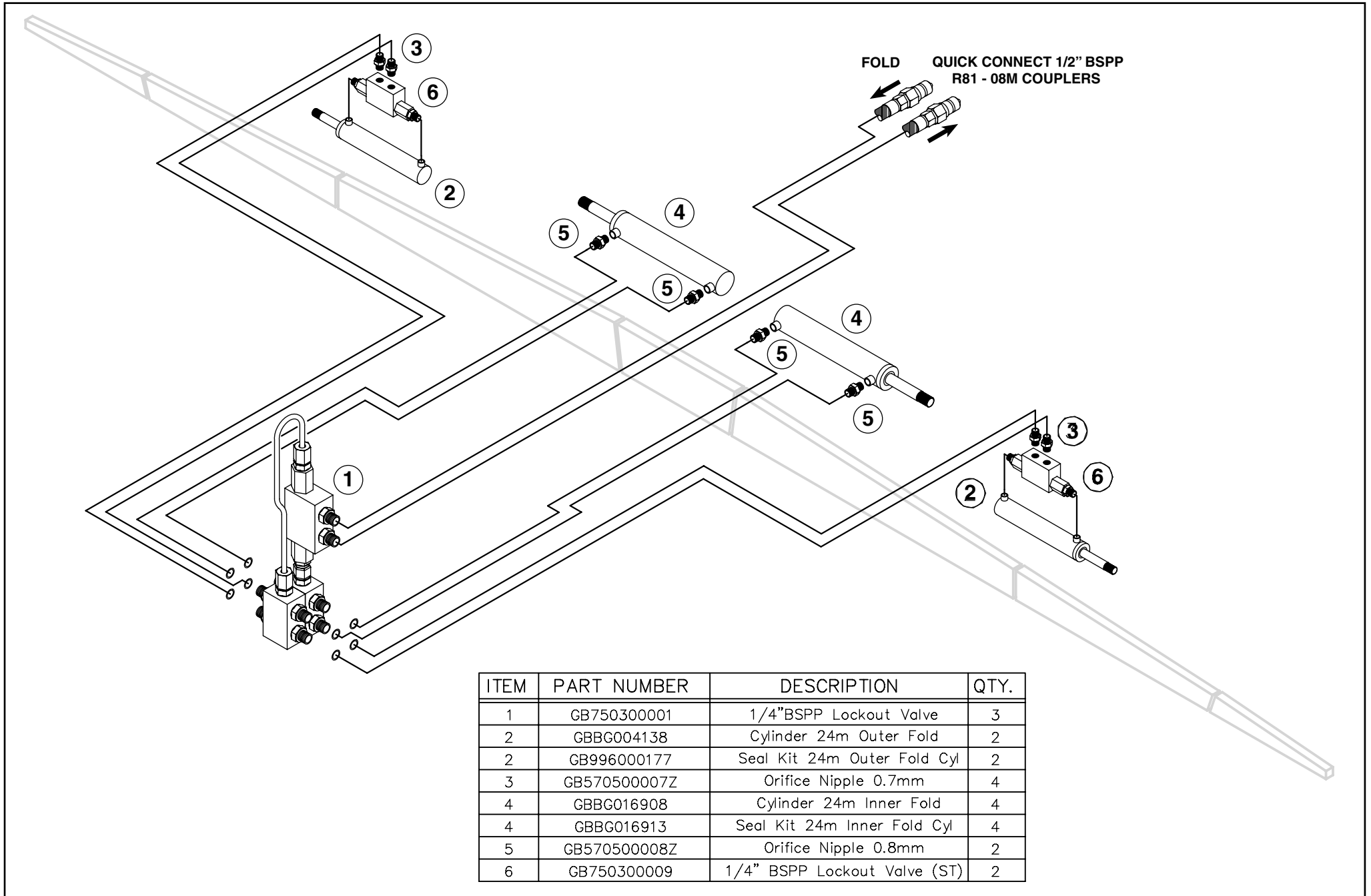

Hydraulic Plumbing Diagram - 24m OWF Assembly Drawings & Parts

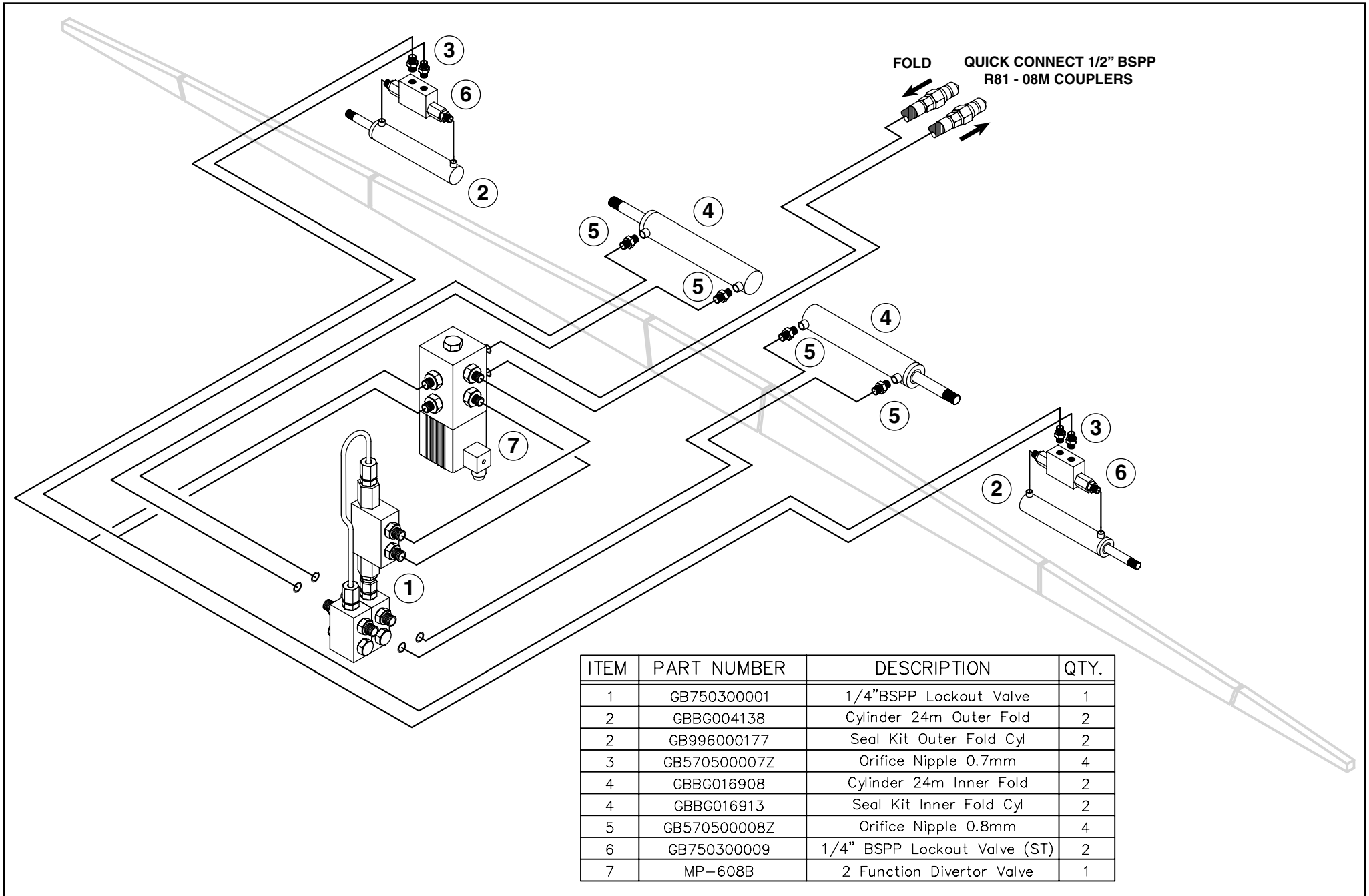

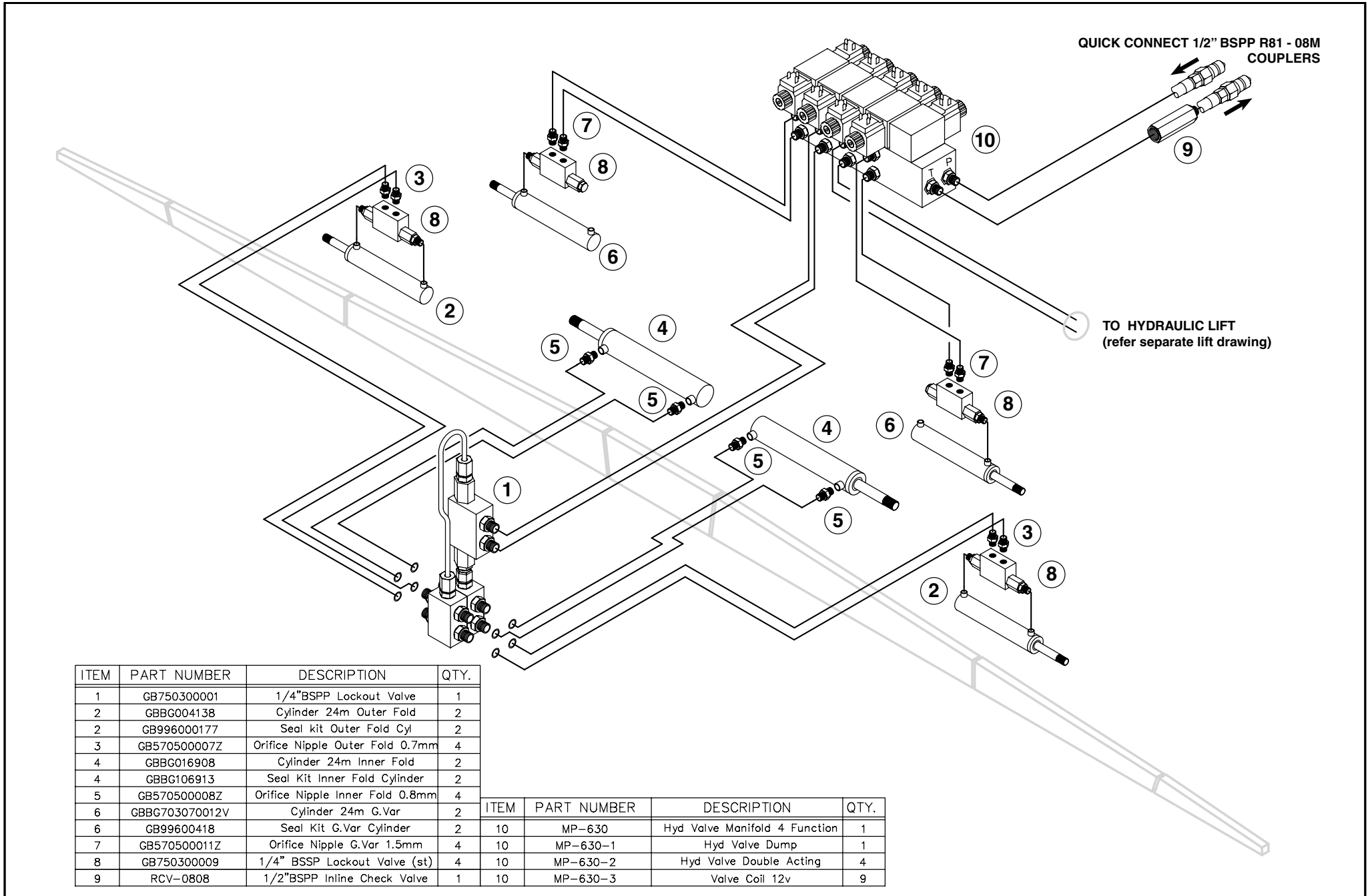

Hydraulic Plumbing Diagram - 24m Gvar & OWF Assembly Drawings & Parts

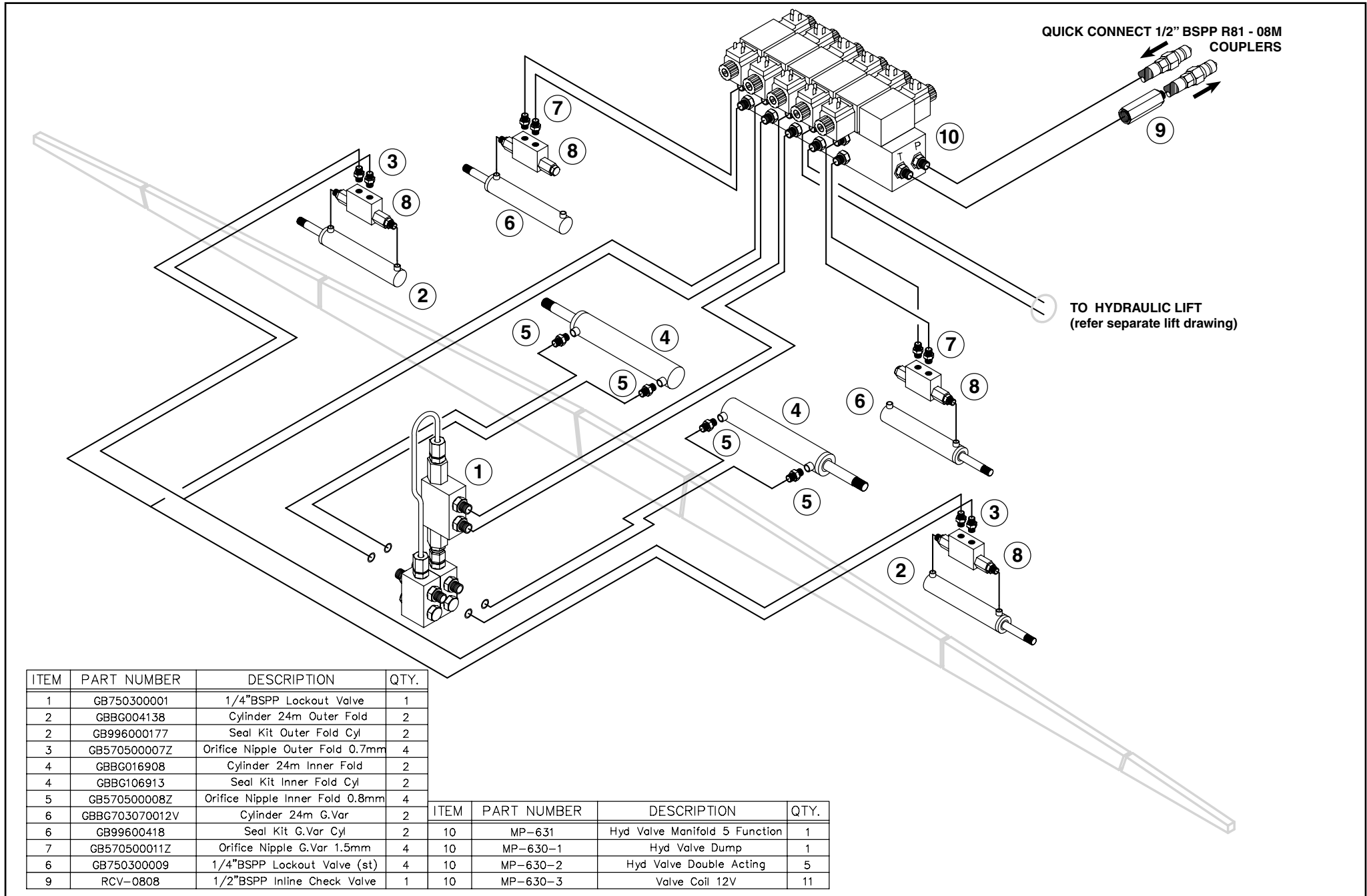

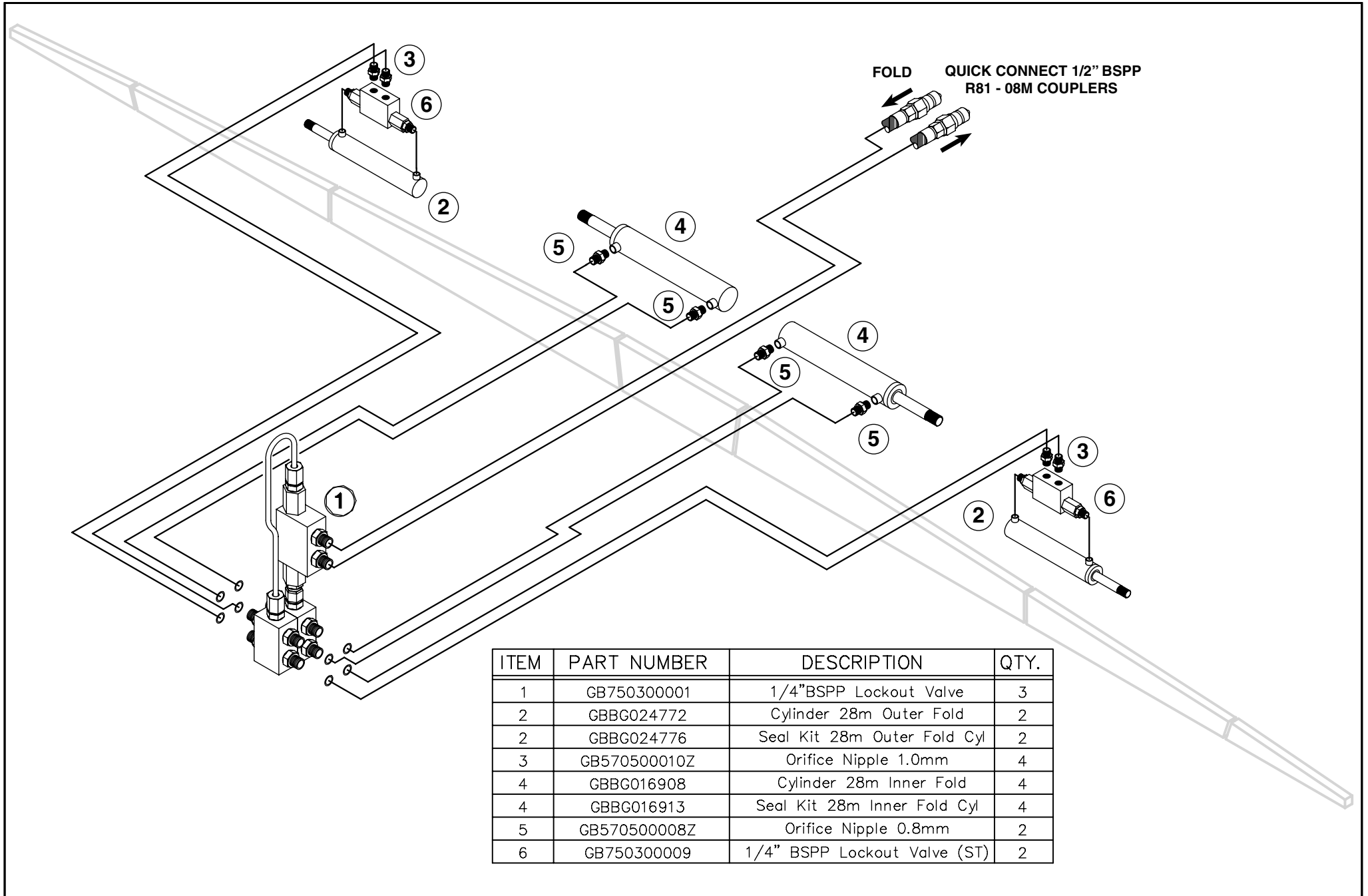

Hydraulic Plumbing Diagram - 28m OWF Assembly Drawings & Parts

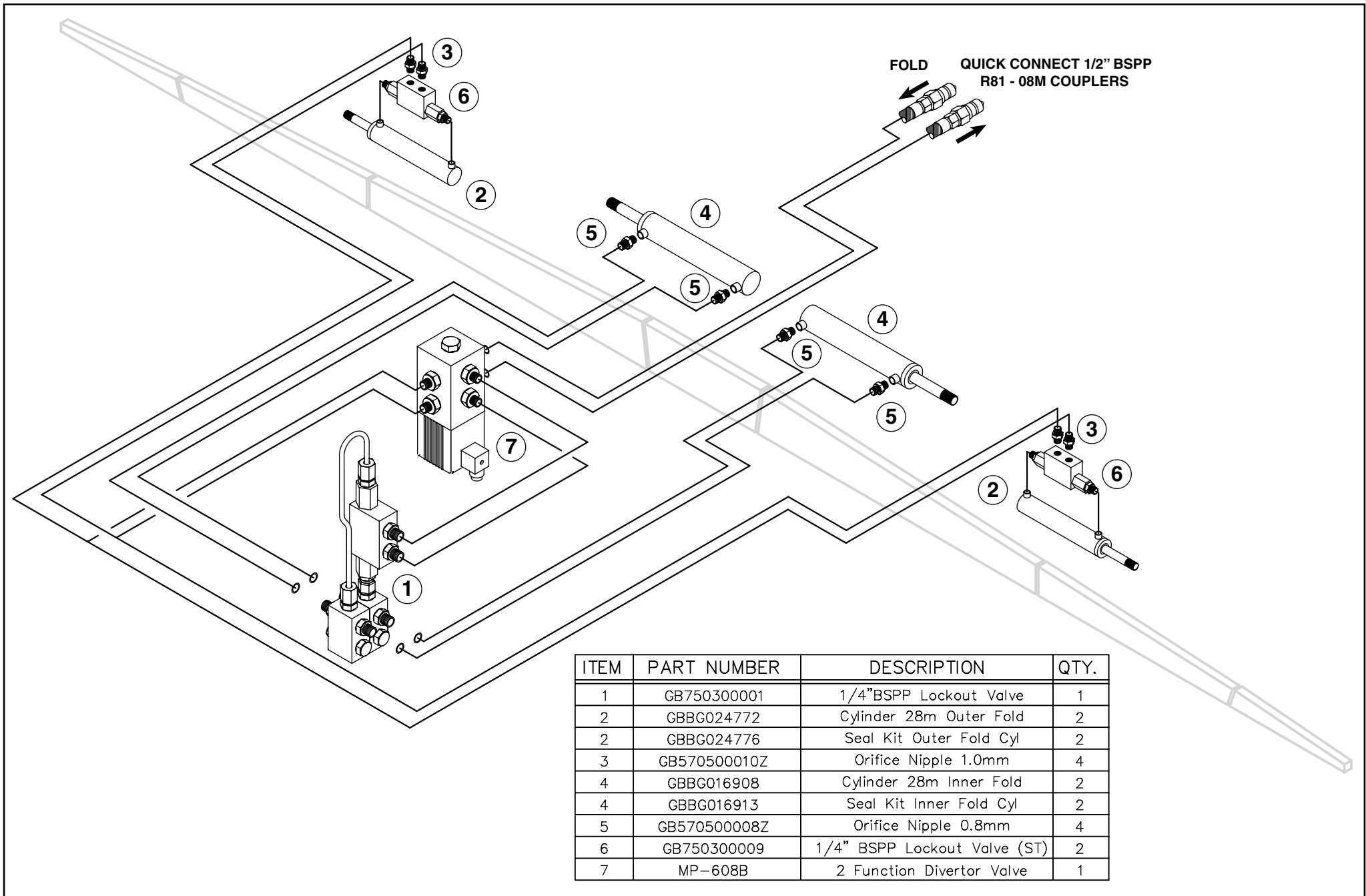

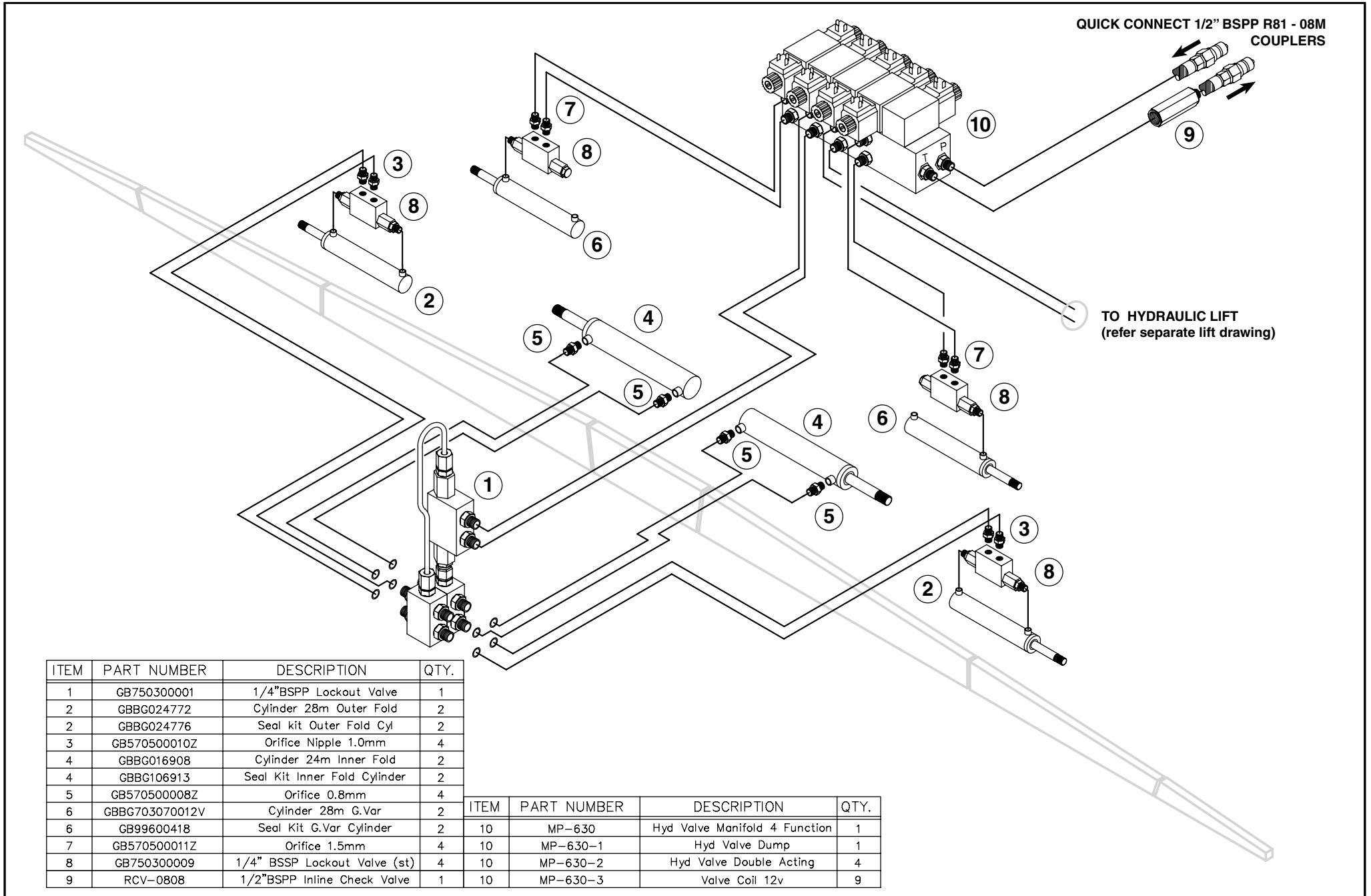

Hydraulic Plumbing Diagram - 28m Gvar & OWF Assembly Drawings & Parts

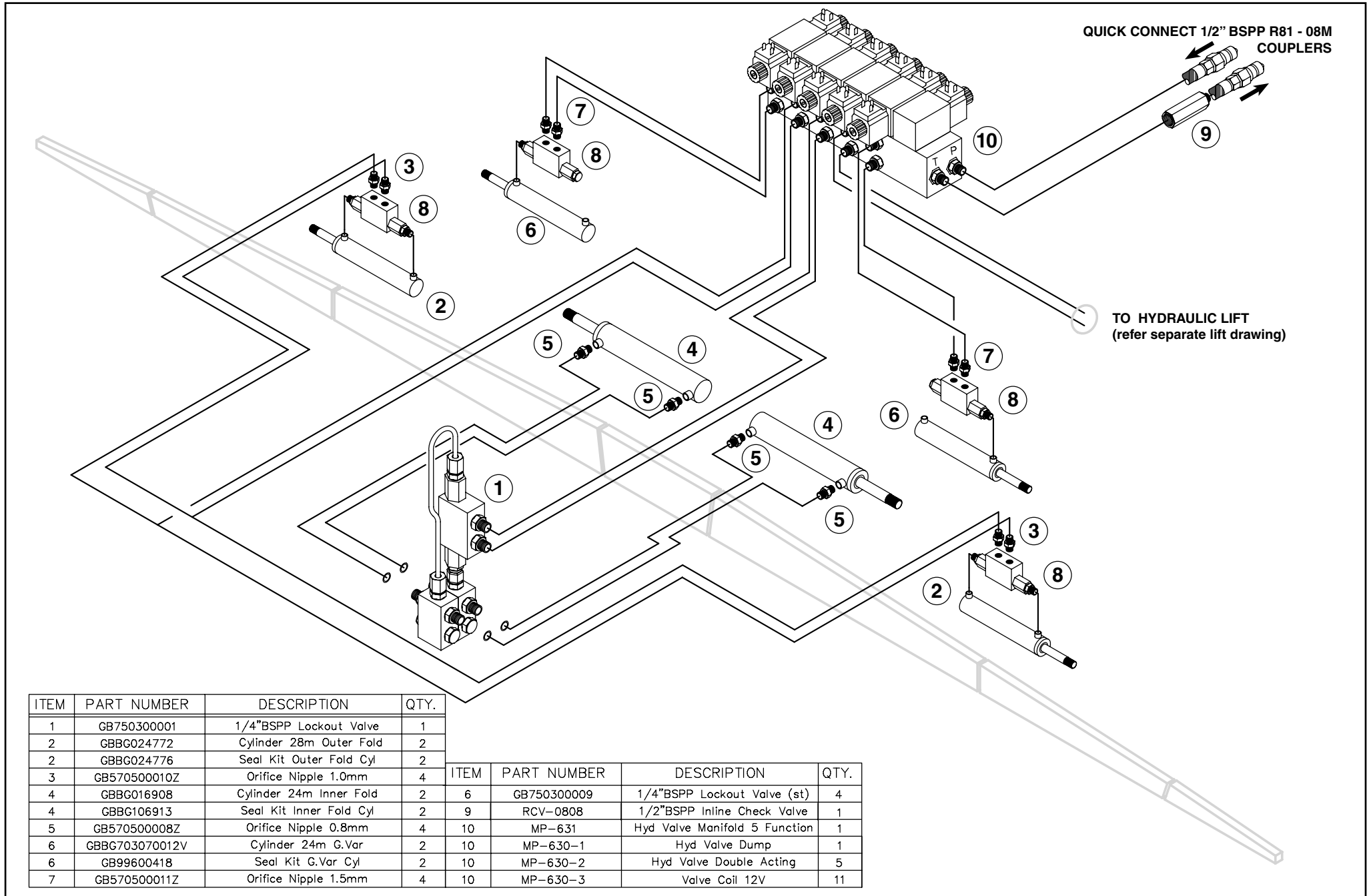

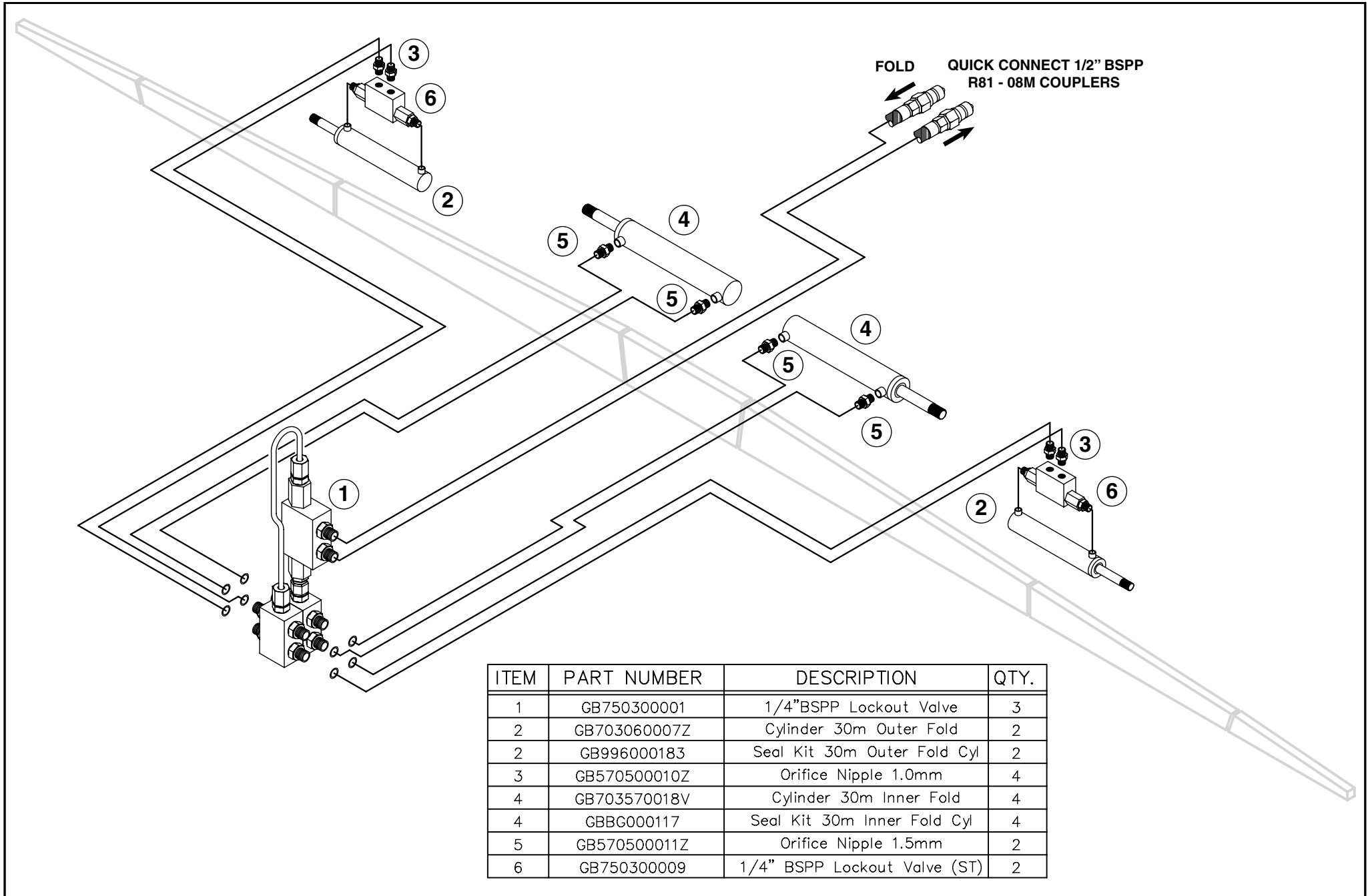

Hydraulic Plumbing Diagram - 30m OWF Assembly Drawings & Parts

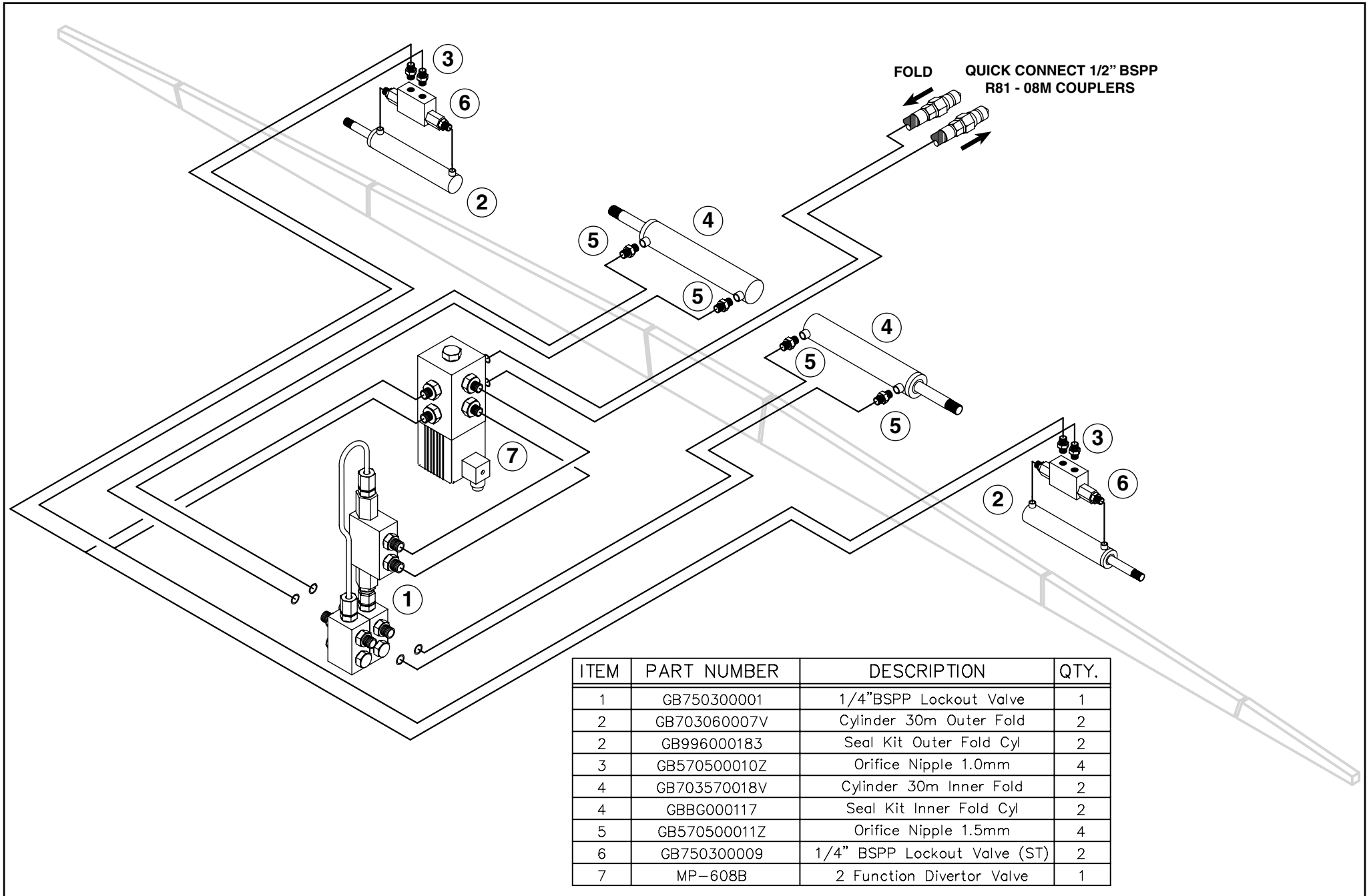

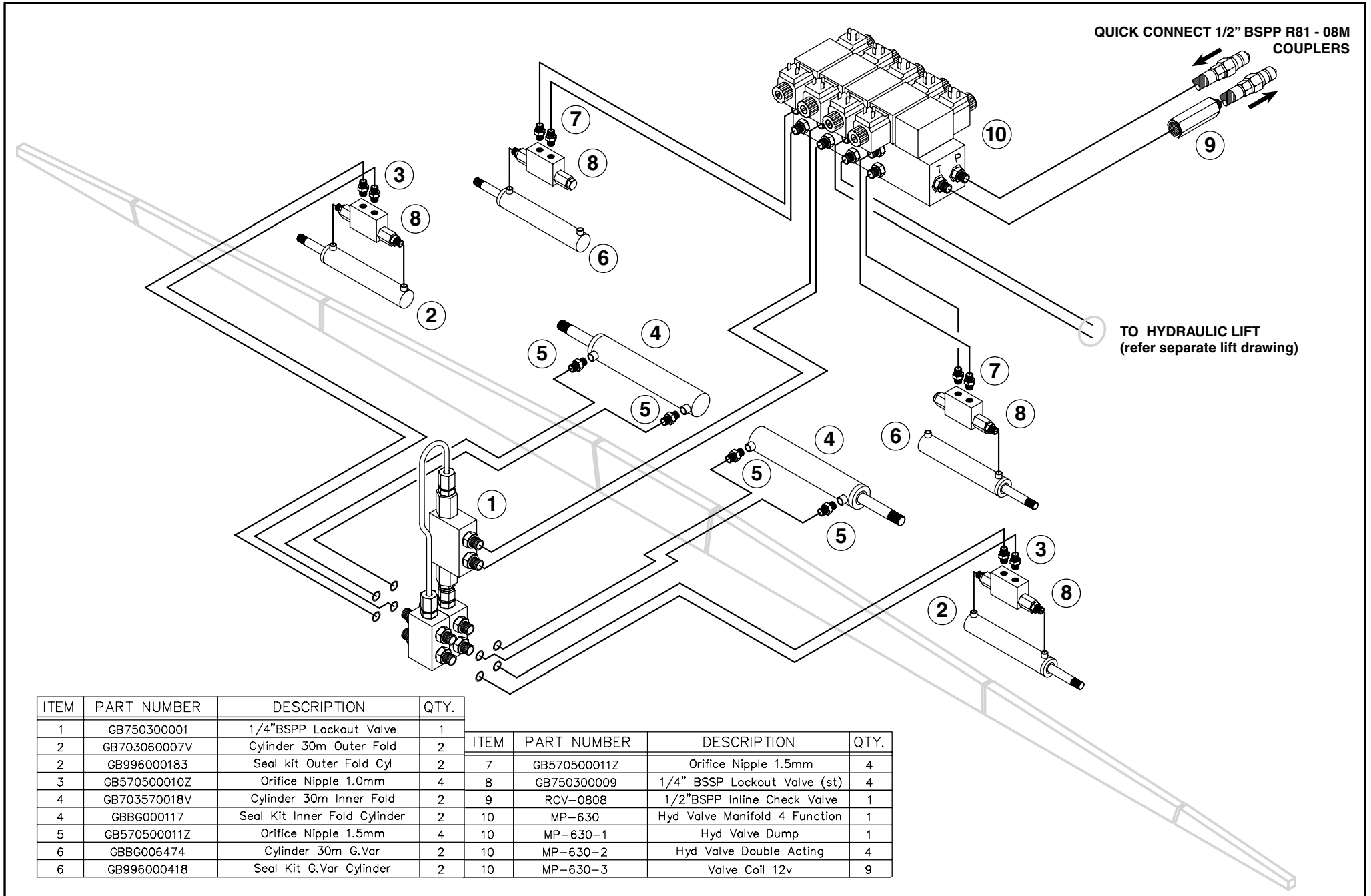

Hydraulic Plumbing Diagram - 30m Gvar & OWF Assembly Drawings & Parts

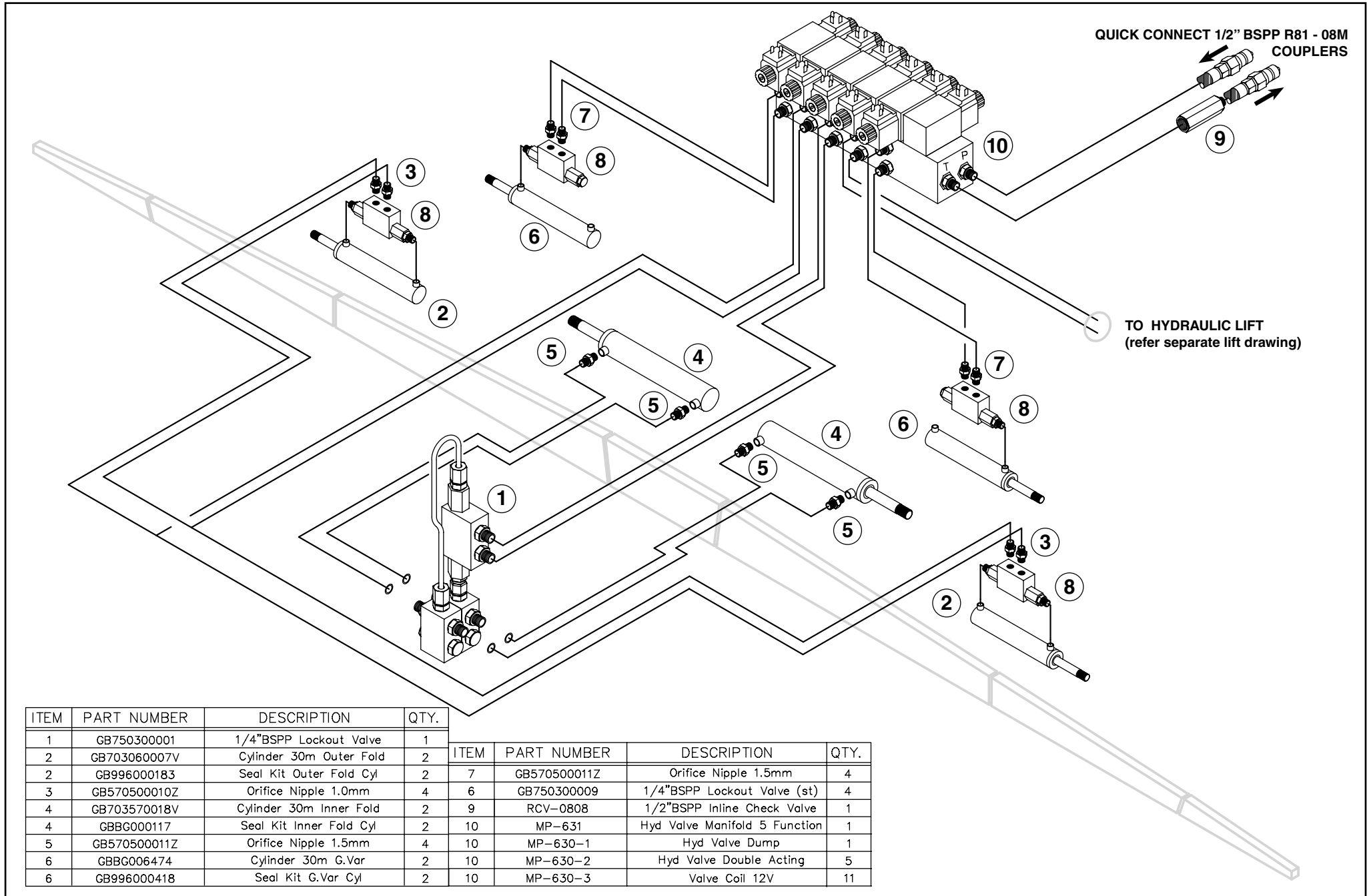

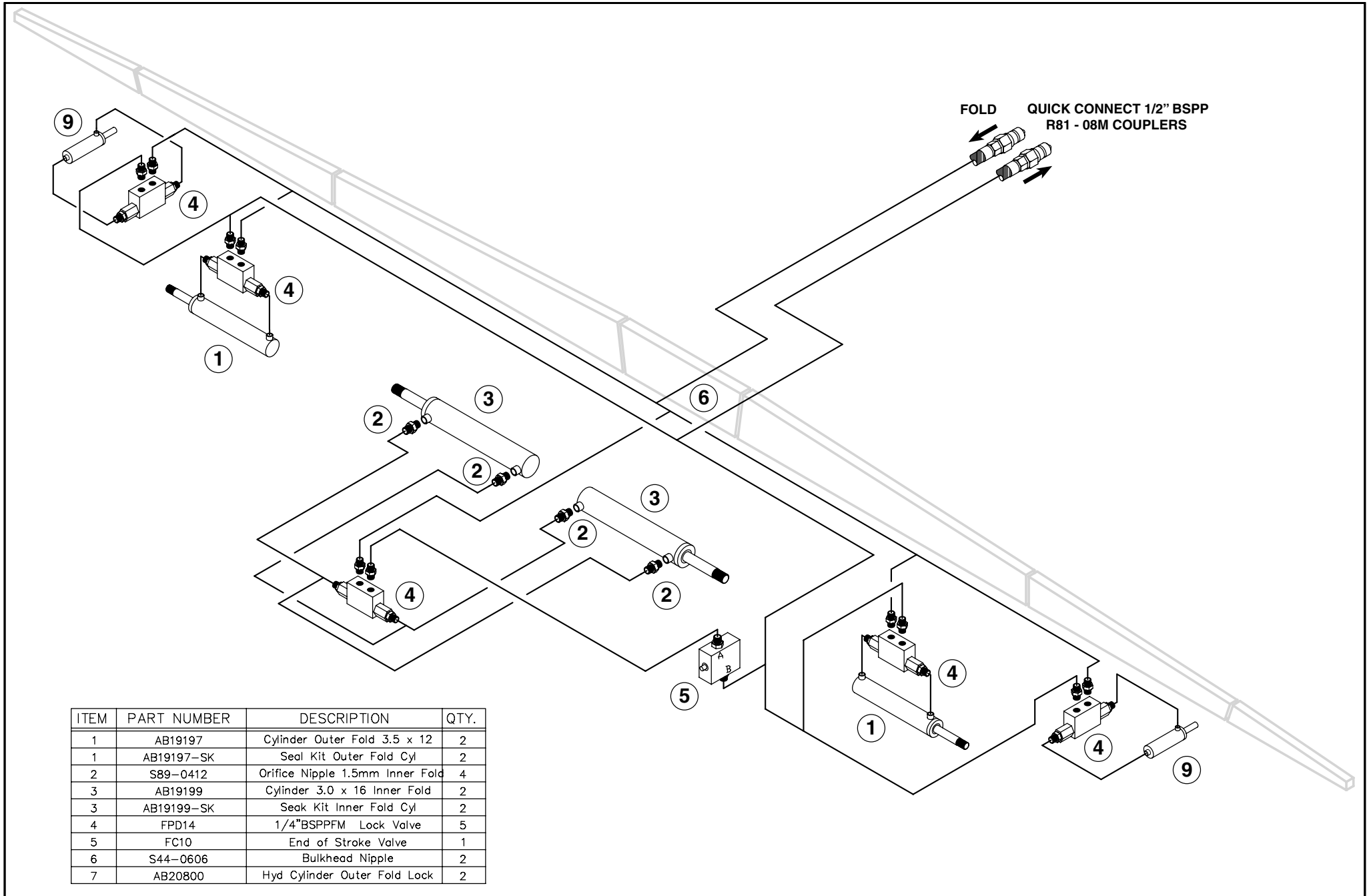

Hydraulic Plumbing Diagram - 33/36m Gvar Assembly Drawings & Parts

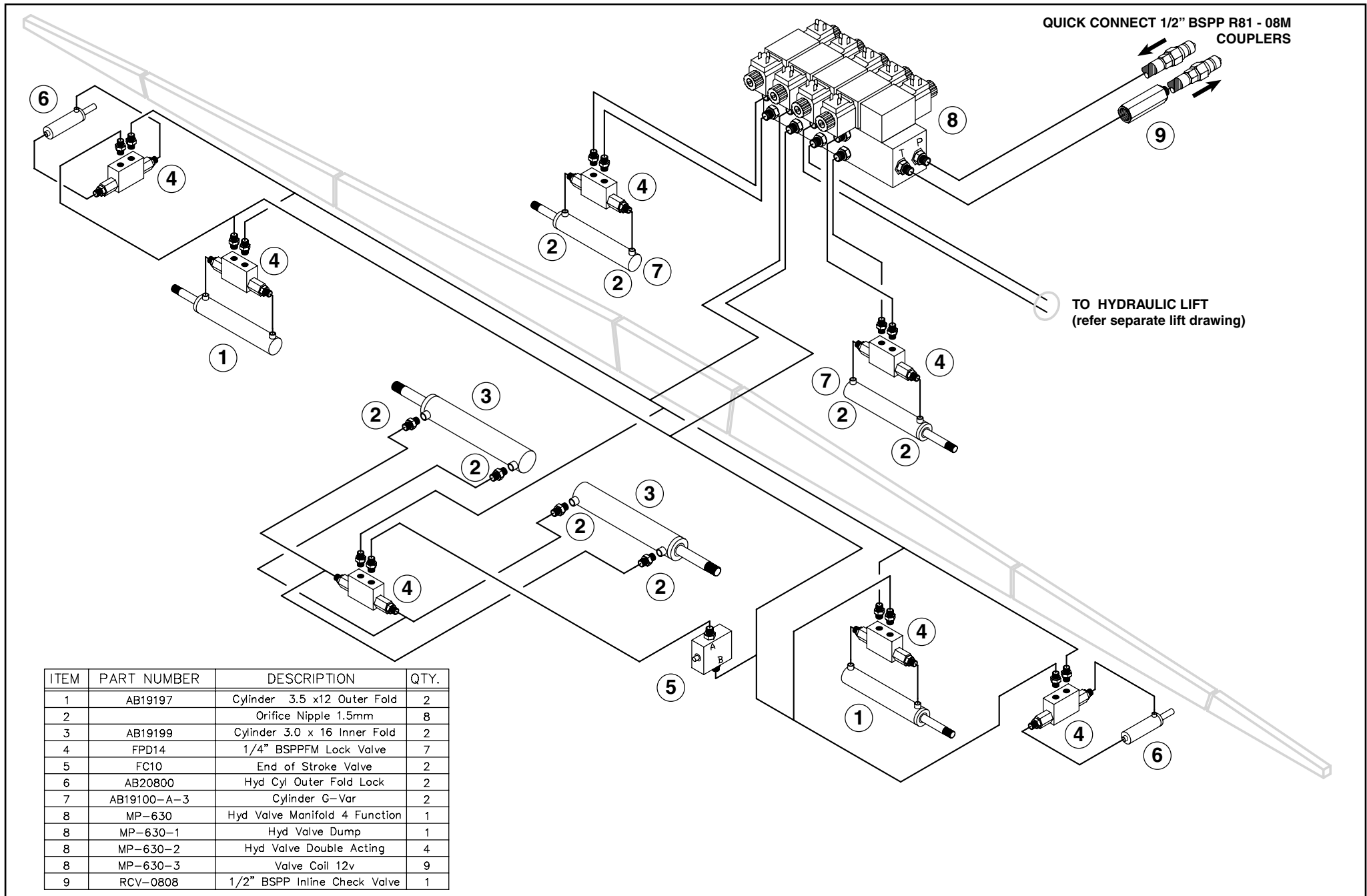

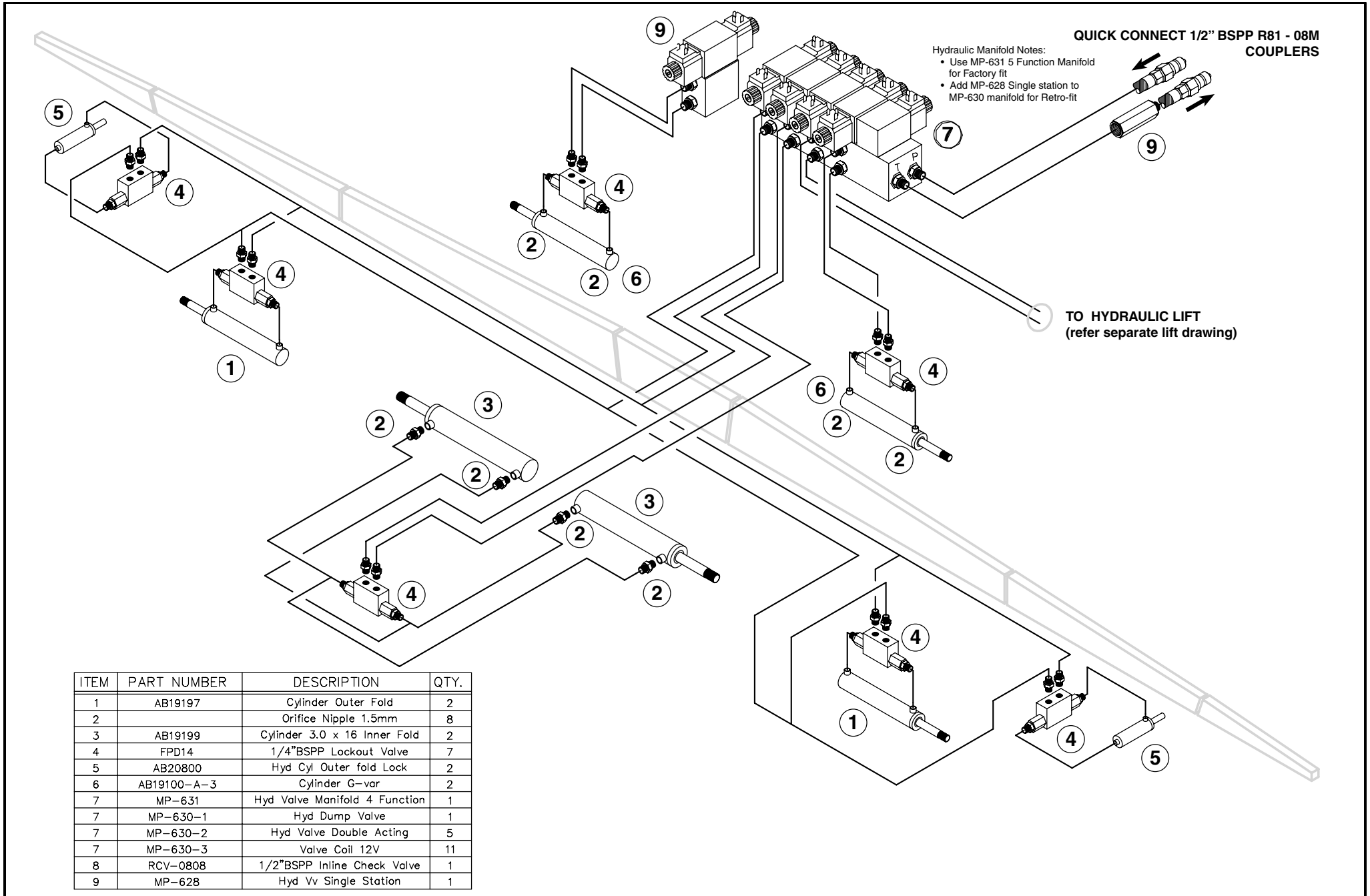

GBCOMPL-24/28CA - Centre Section 24/28m Assembly Drawings & Parts

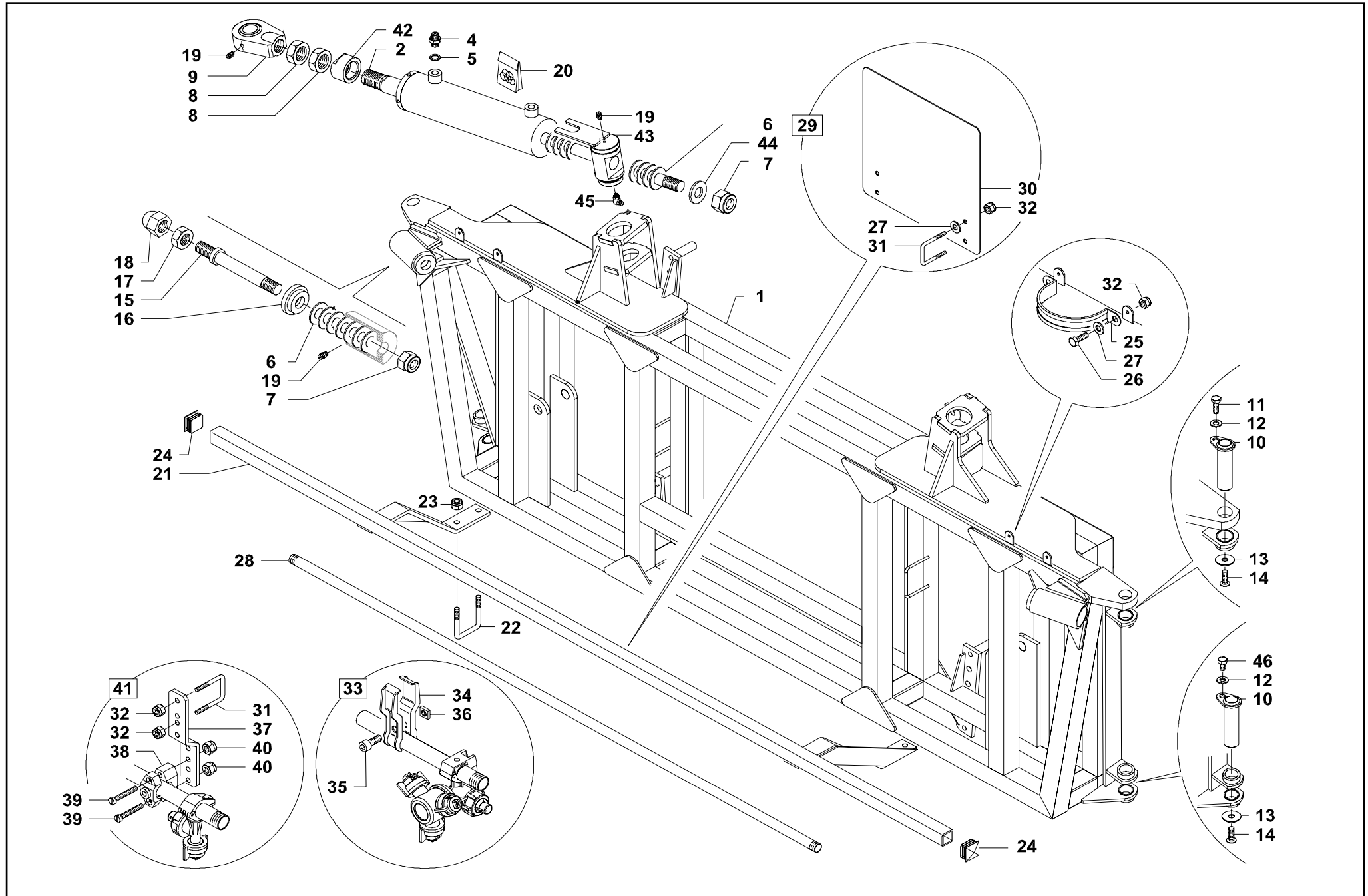

Pos	Part No	Description	Qty
1	<i>GBBG027334</i>	<i>24/28m CENTRE SECTION</i>	1
2	GBBG016908	Inner Fold Ram 24/28m	2
4	GB570500008Z	1/4" NIPPLE 0.8 ORIFICE	4
5	<i>GBBG50243113</i>	<i>COPPER WASHER</i>	4
6	GB912550B30	BELLVILLE WASHER 25mm	156
7	GB905400024	M24 NYLOC NUT (ZINC)	4
8	GB905220027Z	M27 PLAIN NUT (ZINC)	2
9	GB920100043Z	M27 BALL JOINT	2
10	GBBG000024	PIN	4
11	GB900110025Z	M10 x 20mm BOLT (ZINC)	4
12	GB907200010Z	10mm SPRING WASHER	4
13	GB500400004Z	COUNTERSUNK WASHER	4
14	GB900710025Z	COUNTERSUNK SCREW	4
15	GB500100060Z	DAMPNER SHAFT	2
16	GB500400009Z	DAMPNER RETAINER WASHER	2
17	GB905200024Z	M24 PLAIN NUT (ZINC)	2
18	MP-599	M24 DOME NUT	2
19	<i>GB919800020</i>	<i>GREASE NIPPLE</i>	4
20	GBBG016913	SEAL KIT	2
21	GB201800415V	C/SEC RAIL MOUNT BRACKET	1
22	GB500500002Z	U BOLT	2
23	<i>GB905300010</i>	<i>M10 NYLOC NUT (ZINC)</i>	4
24	GB950130030	END CAP	2
25	<i>GB950200059</i>	<i>CABLE RETAINER</i>	2
26	<i>GB900106016Z</i>	<i>M6 x 16mm BOLT (ZINC) 8.8</i>	2
27	<i>GB907106018Z</i>	<i>M6 x 18mm WASHER (ZINC)</i>	10

Pos	Part No	Description	Qty
28	GB550500500	5 HOLE SPRAY RAIL	1
29	<i>GB999900467</i>	<i>WARNING LABEL PLATE KIT</i>	1
30	<i>GB201800065V</i>	<i>WARNING PLATE</i>	1
31	<i>GB50050004Z</i>	<i>M6 U BOLT</i>	5
32	<i>GB905300006</i>	<i>M6 NYLOC NUT (ZINC)</i>	18
33	N/A		
34	N/A		
35	N/A		
36	N/A		
37	<i>GB201800418V</i>	<i>SPRAY TUBE BRACKET</i>	3
38	A425130	SPRAY TUBE 2 PIECE CLAMP	3
39	<i>GB904506040X</i>	<i>M6 x 40mm SCREW STAINLESS</i>	6
40	<i>GB905400006X</i>	<i>M6 NYLOC NUT STAINLESS</i>	
41	GB999900100	SPRAY TUBE MOUNTING KIT	3
42	GB500300030V	Spacer Nut	2
43	GBB027333	Cylinder Swivel Mount	2
44	GB907025044Z	Washer	2
45	GB919800023	Grease Nipple 45 degree	2
46	GB900110014Z	Stud M10	2
NOTE			
<i>Parts in italics are non-stock items and may need to be ordered.</i>			

GBCOMPL-24/28CA - Centre Section 24/28m Assembly Drawings & Parts

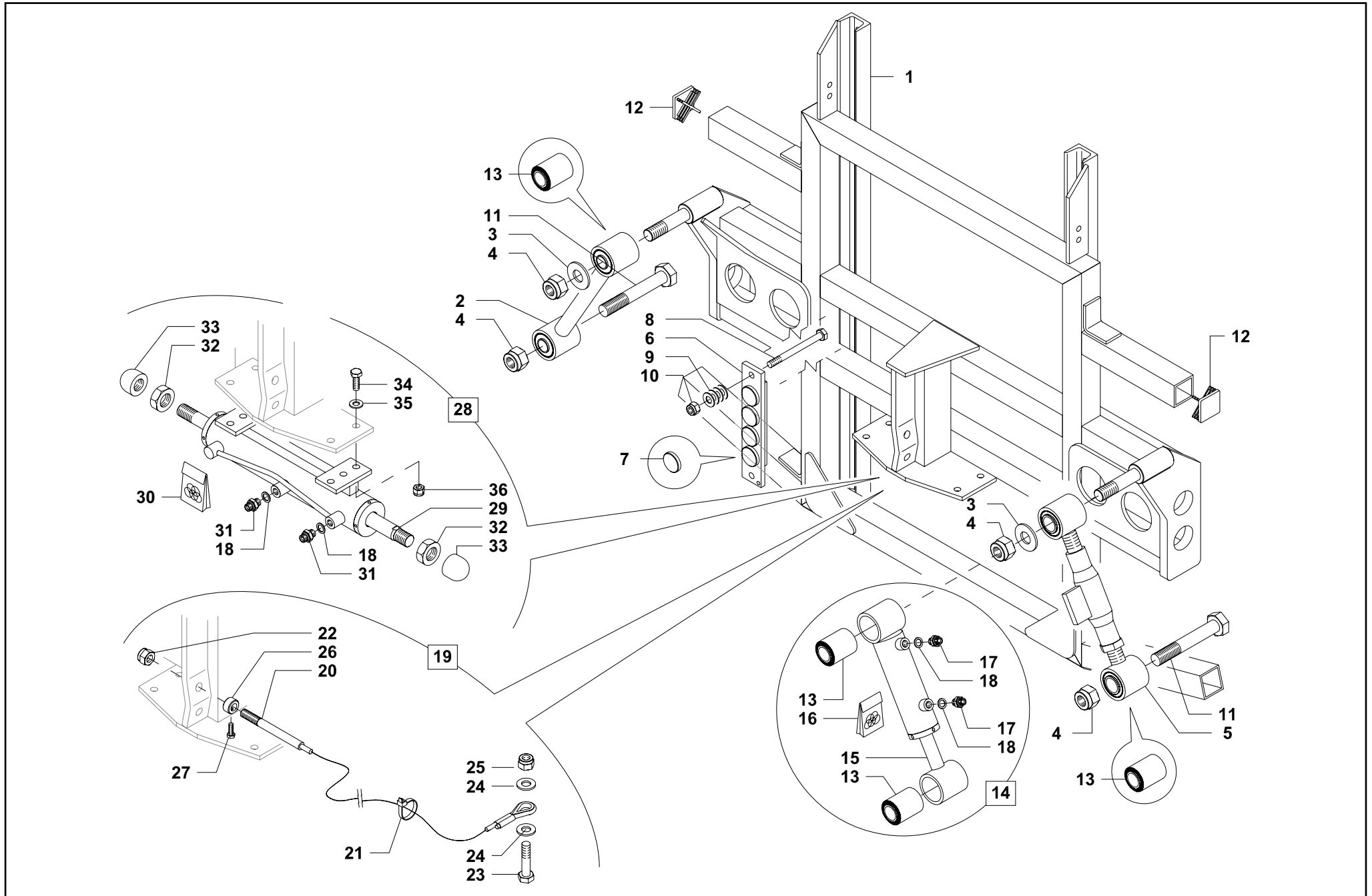

Pos	Part No	Description	Qty
1	GB382000023V	MAIN LEVELLING FRAME	1
2	GB993806001V	TIE ROD ASSY.	1
3	GB500400019Z	M24 WASHER (ZINC)	2
4	GB905400024	M24 NYLOC NUT (ZINC)	4
5	GB993806002Z	TIE ROD ADJUSTABLE ASSY.	1
6	GB993806003V	WEAR PAD ASSY.	8
7	GB950200020	NYLON WEAR DISC	32
8	<i>GB900312100Z</i>	<i>M12 x 90mm BOLT (ZINC) 8.8</i>	4
9	<i>GB911225915</i>	<i>M12 WASHER (ZINC)</i>	12
10	<i>GB905400012</i>	<i>M12 NYLOC NUT (ZINC)</i>	4
11	<i>GB900324130Z</i>	<i>M24 x 130mm BOLT (ZINC) 8.8</i>	2
12	<i>GB950150050</i>	<i>END CAP</i>	4
13	GB950300004	FLEXIBLE BUSH	4
14	GB907000015	TILT RAM ASSY. KIT	1
15	GB702550031V	TILT RAM	1
16	<i>GB996000192</i>	<i>SEAL KIT</i>	1
17	GB570500007Z	1/4" NIPPLE 0.7 ORIFICE	2
18	GB600500001	COPPER WASHER 1/4"	4
19	<i>GB993802005</i>	<i>STRAINER CABLE ASSY. KIT</i>	2
20	GB500700069	STRAINER CABLE	2
21	<i>GB919700120</i>	<i>CABLE TIE</i>	2
22	<i>GB905415014</i>	<i>M14 NUT FINE THREAD (x1.5)</i>	2
23	<i>GB900314060Z</i>	<i>M14 x 60mm BOLT (ZINC) 8.8</i>	2
24	GB907014028Z	M14 WASHER (ZINC)	4
25	<i>GB905300014</i>	<i>M14 NYLOC NUT (ZINC)</i>	2
26	<i>GB919800061Z</i>	<i>LOCKING COLLAR</i>	2
27	<i>GB900106010Z</i>	<i>M6 x 20 BOLT (ZINC)</i>	2

Pos	Part No	Description	Qty
28	GB997000018	LOCK RAM ASSY COMPLETE	1
29	<i>GB702550023V</i>	<i>LOCKING RAM</i>	1
30	<i>GB996000179</i>	<i>SEAL KIT</i>	1
31	GB570500011Z	1/4" NIPPLE 1.5 ORIFICE	2
32	GB905200022Z	M22 NUT	2
33	GB501100007	LOCKING RAM END PIECE	2
34	<i>GB905100035Z</i>	<i>M12 x 35mm BOLT (ZINC) 8.8</i>	4
35	<i>GB907010021Z</i>	<i>M12 WASHER (ZINC)</i>	8
36	<i>GBBG002074</i>	<i>M12 NYLOC NUT (ZINC)</i>	4

NOTE

Parts in italics are non-stock items and may need to be ordered.

GBCOMPL-245-LH or RH - Boom Non Gvar 24m Assembly Drawings & Parts

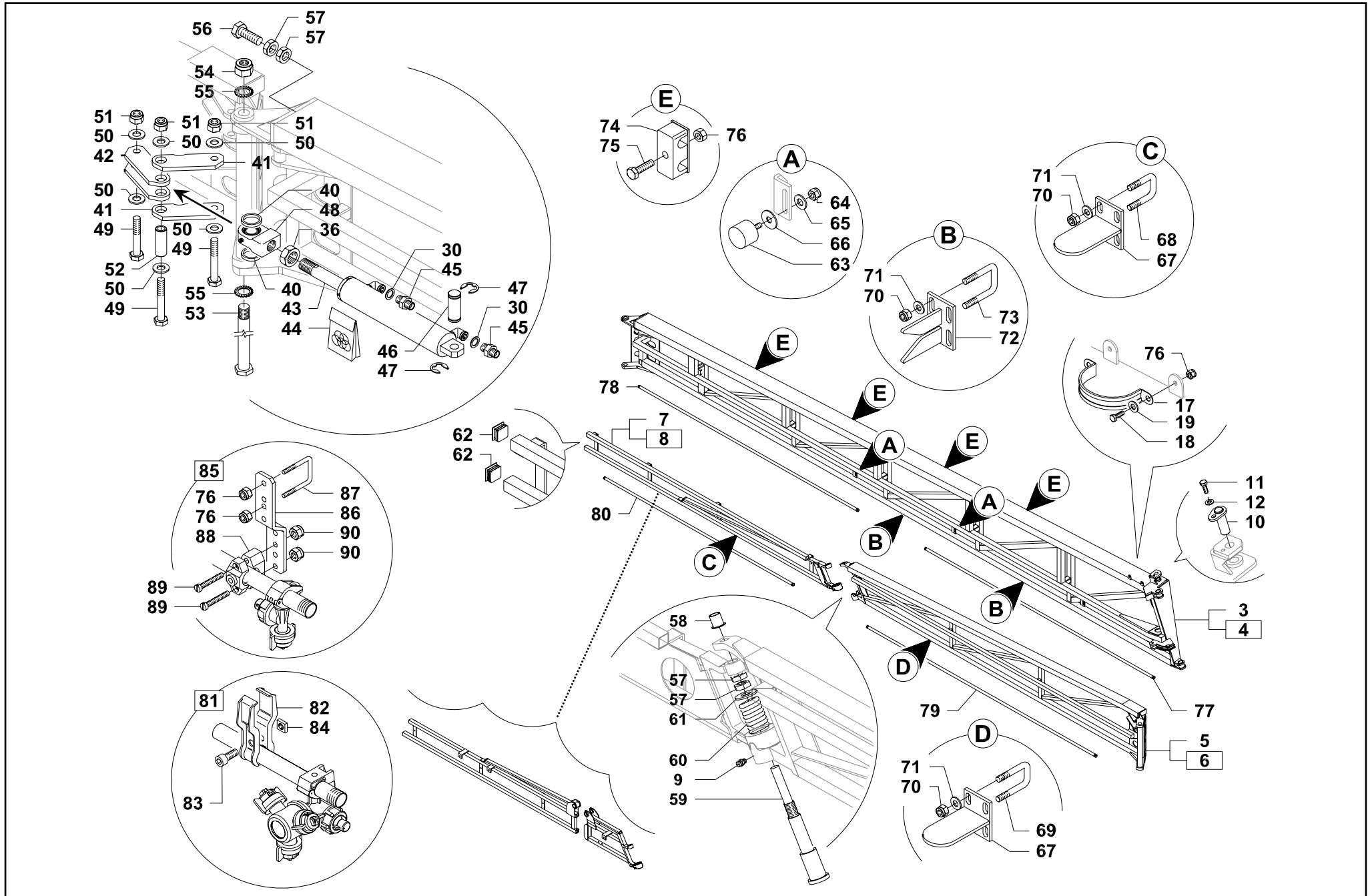

Section 7

GBCOMPL-245-LH or RH - Boom Non Gvar 24m

Pos	Part No	Description	Qty
3	GB022400030V	INNER BOOM ARM R/H	1
4	GB022400031V	INNER BOOM ARM L/H	1
5	GB022400050V	OUTER BOOM ARM R/H	1
6	GB022400051V	OUTER BOOM ARM L/H	1
7	GB201600470V	BREAKAWAY ARM R/H	1
8	GB201600471V	BREAKAWAY ARM L/H	1
9	<i>GB919800020</i>	<i>GREASE NIPPLE</i>	2
10	GB500100055V	PIN	2
12	GB900110025Z	M10 x 20mm BOLT (ZINC) 8.8	2
13	GB907200010Z	10mm SPRING WASHER	2
17	<i>GB950200059</i>	<i>N.A</i>	
18	<i>GB900106016Z</i>	<i>N.A</i>	
19	<i>GB907106018Z</i>	<i>N.A</i>	
30	GB600500001	COPPER WASHER	4
40	GB500200029Z	SPACER	4
41	GB022800037V	LINK ARM ROD	4
42	GB022800036V	LINK ROD	2
43	GBBG004138	CYLINDER OUTER FOLD	2
44	GB996000177	SEAL KIT CYLINDER	2
45	GB570500007Z	NIPPLE 1/4" 0.7MM ORIFICE	4
46	GB500100014Z	PIN FOR CYLINDER	2
47	GB919800030	CIRCLIP	4
48	GB920100053Z	BALL JOINT M27	2
49	<i>GB500516095Z</i>	<i>BOLT</i>	4
50	GB907017030Z	WASHER	12
51	GB905400016	LOCK NUT 16MM	6
52	GB500100081	BUSHING	2
53	GB500100080Z	SHAFT ROD	2
54	GB905400024	SELF-LOCKING NUT M24	6
55	GB907302025Z	WASHER	4
56	GB900124050Z	SCREW	2
57	GB905200024Z	NUT M24	8
58	GB500200049	BUSH	2
59	GB500100111Z	SHAFT BREAKAWAY	2
60	GB919900023Z	SPRING BREAKAWAY	2

Pos	Part No	Description	Qty
61	GB500400019Z	WASHER	2
62	GB950130030	BOOM END CAP	18
63	GB950200004	BOOM STOPPER 20MM	4
63	GB950200001	BOOM STOPPER 30MM	2
64	GB905400008	SELF-LOCKING NUT	6
65	GB907108024Z	WASHER	6
66	<i>GB907110040Z</i>	<i>WASHER</i>	6
67	<i>GB022400053V</i>	<i>BOOM GUIDE TONGUE</i>	2
68	<i>GB500500003Z</i>	<i>U BOLT</i>	2
69	<i>GB500500001Z</i>	<i>UBOLT (LONG)</i>	2
70	<i>GB905400010</i>	<i>NUT</i>	4
71	<i>GB907010021Z</i>	<i>WASHER</i>	4
72	<i>GB022400054V</i>	<i>BOOM GUIDE</i>	2
73	GB500500002Z	UBOLT	2
74	UP-420	HYD HOSE CLAMP	16
75	<i>GB900306035Z</i>	<i>BOLT</i>	16
76	<i>GB905300006</i>	<i>NUT</i>	16
77	GB550501500	5 HOLE SPRAY TUBE	1
78	GB550601500	6 HOLE SPRAY TUBE	1
79	GB550601500	6 HOLE SPRAY TUBE	1
80	GB550501500	5 HOLE SPRAY TUBE	1
81	<i>GB999900004Z</i>	<i>N.A</i>	
82	<i>GB500600002Z</i>	<i>N.A</i>	
83	<i>GB900508022Z</i>	<i>N.A</i>	
84	<i>GB906000008Z</i>	<i>N.A</i>	
85	GB999900100	BOOM TUBE SUPPORT KIT	24
86	<i>GB201800418V</i>	<i>SUPPORT BRACKET</i>	24
87	<i>GB500500004Z</i>	<i>U BOLT</i>	24
88	A425130	TUBE CLAMP	24
89	<i>GB904506040X</i>	<i>SCREW</i>	24
90	<i>GB905400006X</i>	<i>NUT</i>	24

NOTE

Parts in Italics are non-stocked items and may need to be ordered.

GBCOMPL-245-LH or RH - Boom Gvar 24m Assembly Drawings & Parts

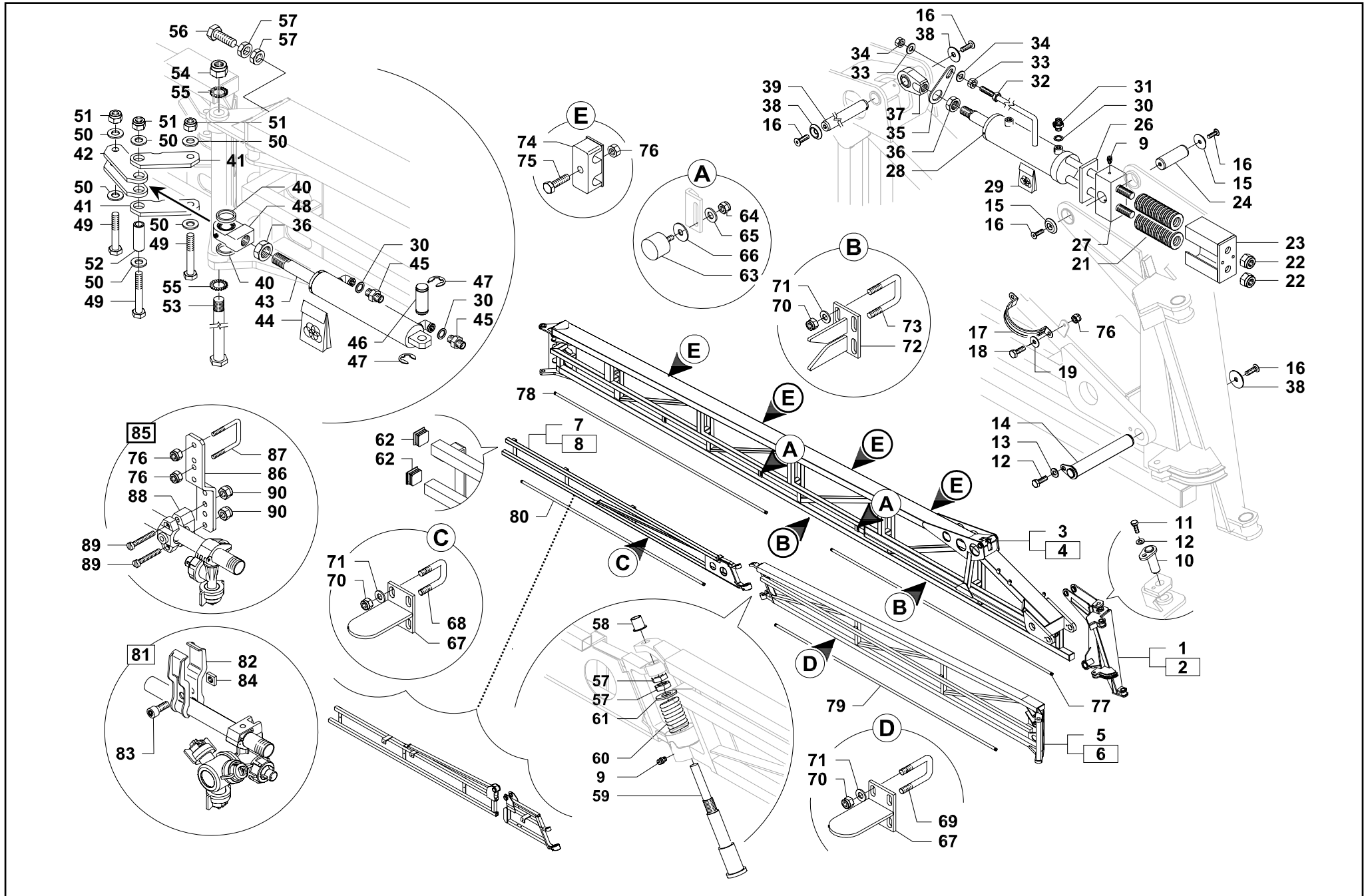

Section 7

GBCOMPL-245-LH or RH - Boom Gvar 24m

Pos	Part No	Description	Qty
1	<i>GBBG026447</i>	<i>G-VAR PIVOT ARM R/H V2</i>	1
2	<i>GBBG026449</i>	<i>G-VAR PIVOT ARM L/H V2</i>	1
3	<i>GBBG026378</i>	<i>G-VAR INNER ARM R/H V2</i>	1
4	<i>GBBG026379</i>	<i>G-VAR INNER ARM L/H V2</i>	1
5	GB022400050V	OUTER BOOM ARM R/H	1
6	GB022400051V	OUTER BOOM ARM L/H	1
7	<i>GBBG020414</i>	<i>BREAKAWAY ARM R/H</i>	1
8	<i>GBBG020415</i>	<i>BREAKAWAY ARM L/H</i>	1
9	<i>GB919800020</i>	<i>GREASE NIPPLE</i>	2
10	GB500100055V	PIN	2
12	GB900110025Z	M10 x 20mm BOLT (ZINC)	2
13	GB907200010Z	10mm SPRING WASHER	2
14	<i>GBBG025153</i>	<i>G-VAR BOTTOM PIN V2</i>	2
15	GB500400008Z	COUNTERSUNK WASHER	4
16	GB900710025Z	SCREW M10X25	10
17	<i>GB950200059</i>	<i>CABLE RETAINER</i>	4
18	<i>GB900106016Z</i>	<i>M6 x 16mm BOLT (ZINC) 8.8</i>	8
19	<i>GB907106018Z</i>	<i>M6 x 18mm WASHER (ZINC)</i>	8
21	GB919900043V	G-VAR RAM SPRING (LARGE)	4
22	GB905400020	M24 (FINE) NYLOC NUT (ZINC)	2
23	GB022400209V	SPRING RETAINER	2
24	GB500100125	PIN 300X 95L	2
26	GB022400210	RUBBER PAD	2
27	GB022400208Z	CLUTCH	2
28	<i>GBBG000022</i>	<i>HYDRAULIC RAM</i>	2
29	GB996000418	SEAL KIT	2
30	GB600500001	COPPER WASHER	4
31	GB570500011Z	NIPPLE 1/4 BSP 1.2 ORIFICE	2
32	GB271600045V	BOOM LEVEL INDICATOR	2
33	<i>GB905100010Z</i>	<i>LOCKING NUT</i>	4
34	GB907010021Z	M10 WASHER (ZINC)	4
35	GB271600046V	INDICATOR LOCKING PLATE	2
36	<i>GB905220024Z</i>	<i>M24 NUT (ZINC)</i>	2
37	GB920100034Z	M24 BALL JOINT	2
38	GB500400004Z	COUNTERSUNK WASHER	4

Pos	Part No	Description	Qty
39	GB500100086	PIN	2
40	GB500200029Z	SPACER	4
41	GB022800037V	LINK ARM ROD	4
42	GB022800036V	LINK ROD	2
43	<i>GBBG004138</i>	<i>CYLINDER OUTER FOLD</i>	2
44	GB996000177	SEAL KIT CYLINDER	2
45	GB570500007Z	NIPPLE 1/4" 0.7MM ORIFICE	4
46	GB500100014Z	PIN FOR CYLINDER	2
47	GB919800030	CIRCLIP	4
48	GB920100053Z	BALL JOINT M27	2
49	<i>GB500516095Z</i>	<i>BOLT</i>	4
50	GB907017030Z	WASHER	12
51	GB905400016	LOCK NUT 16MM	6
52	GB500100081	BUSHING	2
53	GB500100080Z	SHAFT ROD	2
54	GB905400024	SELF-LOCKING NUT M24	6
55	GB907302025Z	WASHER	4
56	GB900124050Z	SCREW	2
57	GB905200024Z	NUT M24	8
58	GB500200049	BUSH	2
59	GB500100111Z	SHAFT BREAKAWAY	2
60	GB919900023Z	SPRING BREAKAWAY	2
61	GB500400019Z	WASHER	2
62	GB950130030	BOOM END CAP	18
63	GB950200004	BOOM STOPPER 20MM	4
63	GB950200001	BOOM STOPPER 30MM	2
64	GB905400008	SELF-LOCKING NUT	6
65	GB907108024Z	WASHER	6
66	<i>GB907110040Z</i>	<i>WASHER</i>	6
67	<i>GB022400053V</i>	<i>BOOM GUIDE TONGUE</i>	2
68	<i>GB500500003Z</i>	<i>U BOLT</i>	2
69	<i>GB500500001Z</i>	<i>UBOLT (LONG)</i>	2
70	<i>GB905400010</i>	<i>NUT</i>	4

NOTE
Parts in Italics are non-stocked items and may need to be ordered.

GBCOMPL-285-LH or RH - Boom Non Gvar 28m Assembly Drawings & Parts

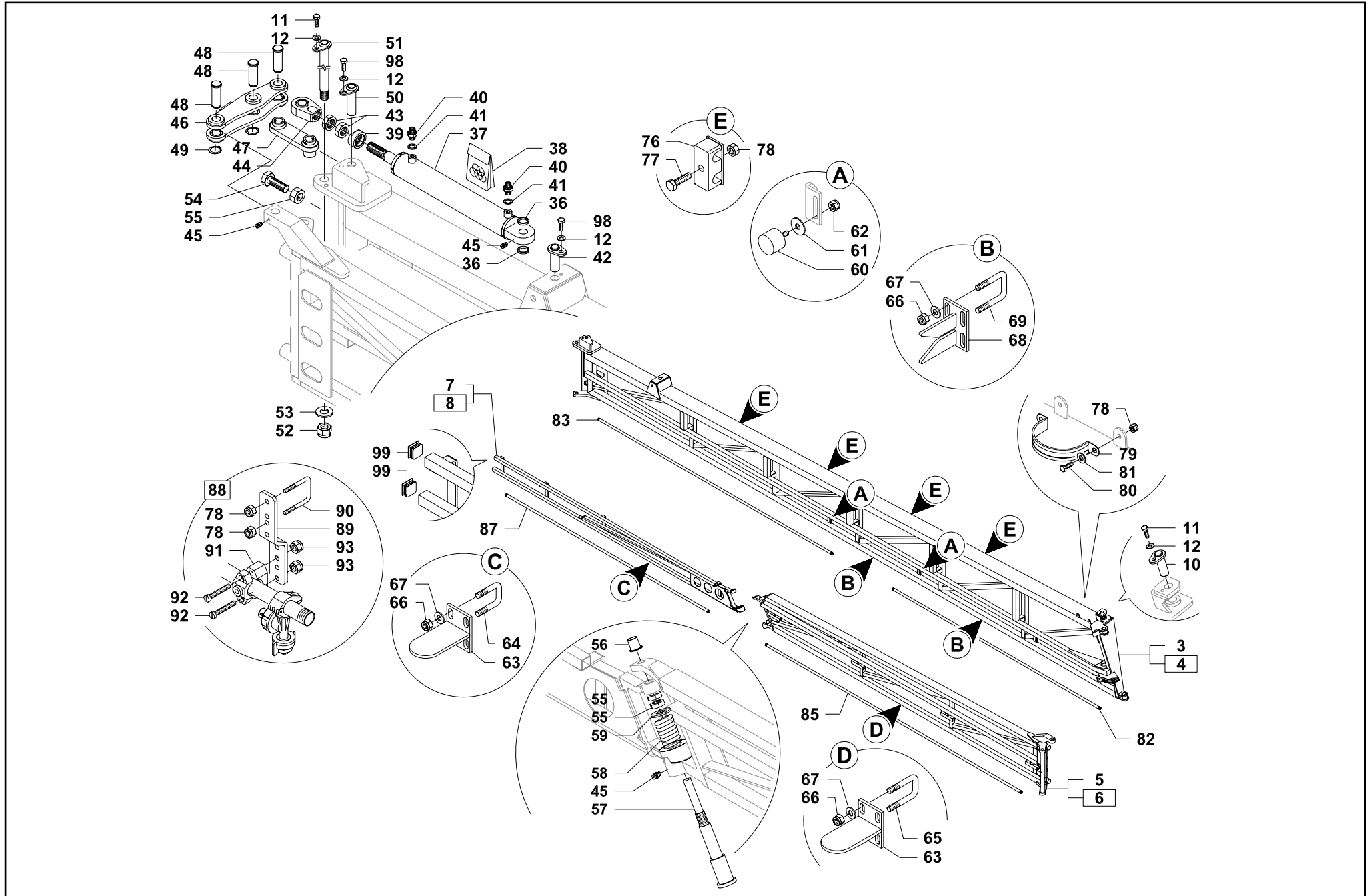

Section 7

GBCOMPL-285-LH or RH - Boom Non Gvar 28m

Pos	Part No	Description	Qty
3	<i>GBBG002915</i>	<i>INNER BOOM ARM R/H</i>	1
4	GBBG002916	INNER BOOM ARM L/H	1
5	GB022400050V	OUTER BOOM ARM R/H	1
6	GB022400051V	OUTER BOOM ARM L/H	1
7	<i>GB22800080V</i>	<i>BREAKAWAY ARM R/H</i>	1
8	<i>GB22800081V</i>	<i>BREAKAWAY ARM L/H</i>	1
10	GB500100055V	PIN	2
11	GB900110025Z	M10 x 20mm BOLT (ZINC) 8.8	2
12	GB907200010Z	10mm SPRING WASHER	2
36	GB500200028Z	SPACER	4
37	<i>GB024772</i>	<i>HYDRAULIC RAM</i>	2
38	<i>GB024776</i>	<i>SEAL KIT</i>	2
39	GB003273	SPACER NUT M27	2
40	GB570500010Z	NIPPLE 1/4 BSP 1.0 ORIFICE	8
41	<i>GB50243113</i>	<i>COPPER WASHER</i>	8
42	GB500100055V	PIN	2
43	GB905220027Z	M27 PLAIN NUT (ZINC)	4
44	GB920100043Z	M27 BALL JOINT	4
45	<i>GB919800020</i>	<i>GREASE NIPPLE</i>	16
46	GB006461	LINK ARM OUTER FOLD	4
47	<i>GB023200216V</i>	<i>LINK ARM PIVOT</i>	2
48	GB006426	PIN	6
49	GB000187	CIRCLIP	12
50	GB500100110V	PIN	2
51	GB500100146V	PIN 28 2ND FOLD	2
52	GB905400024	M24 NYLOC NUT (ZINC)	2
53	<i>GB907025044Z</i>	<i>M24 WASHER (ZINC)</i>	2
54	GB900124050Z	SCREW	2
55	GB905200024Z	M24 PLAIN NUT (ZINC)	4
56	GB500200049	BUSH	2
57	GB500100111Z	BREAKAWAY SHAFT	2
58	GB919900023Z	BREAKAWAY SPRING	2
59	GB500400019Z	WASHER	2
60	GB950200004	RUBBER STOPPER 20mm	4

Pos	Part No	Description	Qty
60	GB950200001	RUBBER STOPPER 30mm	
61	GB907108024Z	M8 X 24mm WASHER	4
62	<i>GB905400008</i>	<i>M8 NYLOC NUT (ZINC)</i>	4
63	<i>GB022400053V</i>	<i>WING SUPPORT MALE</i>	4
64	XBMBB32	32mm U BOLT (M10)	4
65	XBMBB	40mm U BOLT (M10)	4
66	<i>GB905400010</i>	<i>M10 NYLOC NUT (ZINC)</i>	32
67	<i>GB907010021Z</i>	<i>M10 WASHER (ZINC)</i>	32
68	<i>GB022400054V</i>	<i>WING SUPPORT FEMALE</i>	4
69	XBMBB50	50mm U BOLT (M10)	8
76	<i>GB950200058</i>	<i>CABLE RETAINER</i>	12
77	<i>GB900306035Z</i>	<i>M6 x 35mm BOLT (ZINC)</i>	12
78	<i>GB905300006</i>	<i>M6 NYLOC NUT (ZINC)</i>	124
79	<i>GB950200059</i>	<i>CABLE RETAINER</i>	4
80	<i>GB900106016Z</i>	<i>M6 x 35mm BOLT (ZINC)</i>	8
81	<i>GB907106018Z</i>	<i>6mm WASHER (ZINC)</i>	8
82	GB550700500	7 HOLE SPRAY TUBE	2
83	GB550600500	6 HOLE SPRAY TUBE	2
85	GB550700500	7 HOLE SPRAY TUBE	2
87	GB550600500	6 HOLE SPRAY TUBE	2
88	GB999900100	SPRAY TUBE SUPPORT KIT	26
89	<i>GB2018000418V</i>	<i>SPRAY TUBE BRACKET</i>	26
90	<i>GB500500004Z</i>	<i>SPRAY TUBE U BOLT</i>	26
91	A425130	SPRAY TUBE 2 PIECE CLAMP	26
92	<i>GB904506040X</i>	<i>M6 x 40mm SCREW STAINLESS</i>	52
93	<i>GB905400006X</i>	<i>M6 NYLOC NUT STAINLESS</i>	52
98	<i>GB900110020Z</i>	<i>M10 x 20mm BOLT (ZINC)</i>	2
99	GB950130030	END CAP	

NOTE

Parts in italics are non-stock items and may need to be ordered.

GBCOMPL-285GV-LH or RH - Boom Gvar 28m Assembly Drawings & Parts

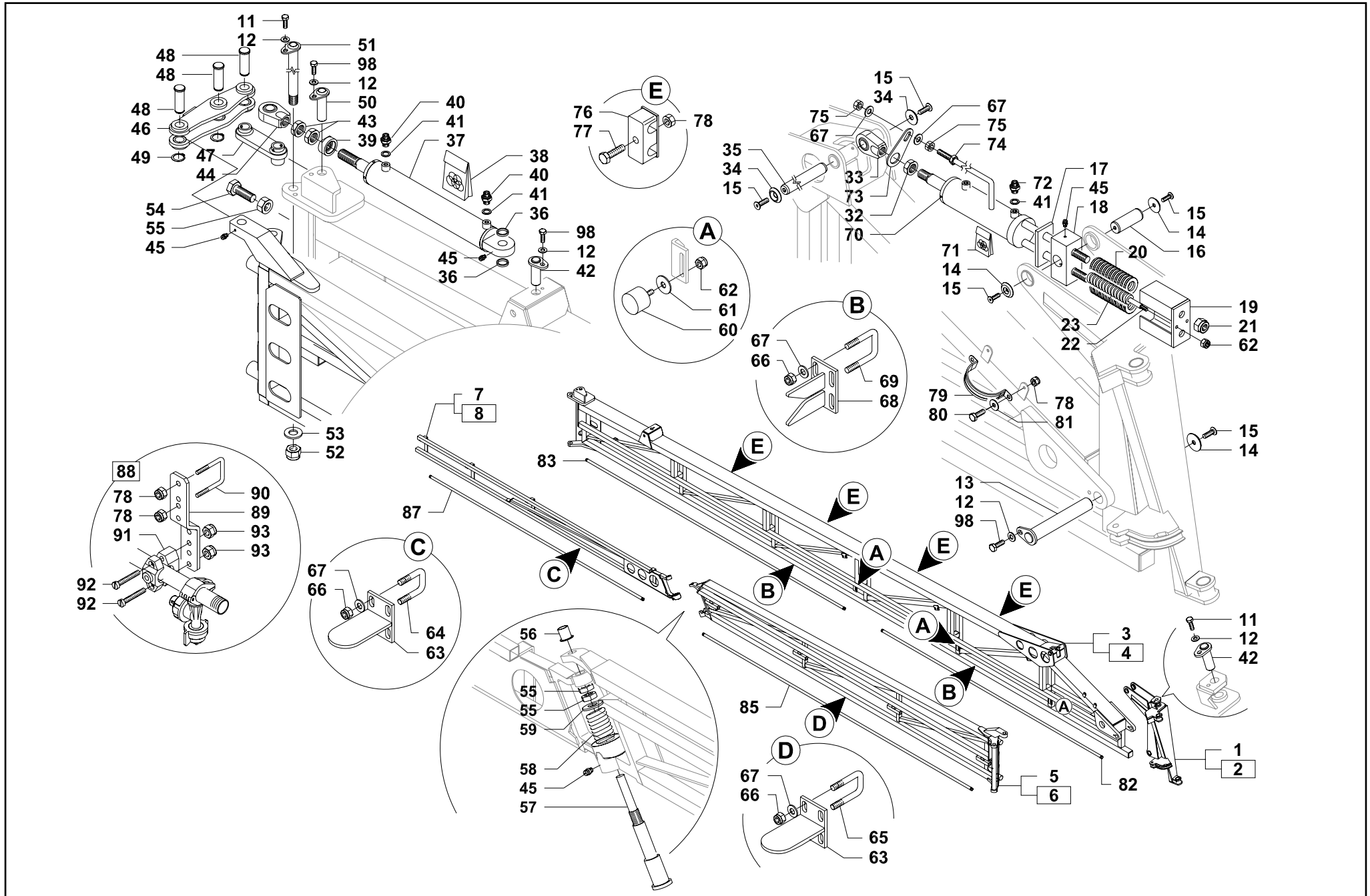

Section 7

GBCOMPL-285GV-LH or RH - Boom Gvar 28m

Pos	Part No	Description	Qty
1	<i>GBBG026447</i>	<i>G-VAR PIVOT ARM R/H V2</i>	1
2	<i>GBBG026449</i>	<i>G-VAR PIVOT ARM L/H V2</i>	1
3	<i>GBBG026315</i>	<i>G-VAR INNER ARM R/H V2</i>	1
4	<i>GBBG026316</i>	<i>G-VAR INNER ARM L/H V2</i>	1
5	GB022400050V	OUTER BOOM ARM R/H	1
6	GB022400051V	OUTER BOOM ARM L/H	1
7	<i>GB22800080V</i>	<i>BREAKAWAY ARM R/H V2</i>	1
8	<i>GB22800081V</i>	<i>BREAKAWAY ARM L/H V2</i>	1
10	GB500100055V	PIN	2
11	GB900110025Z	M10 x 20mm BOLT (ZINC)	2
12	GB907200010Z	10mm SPRING WASHER	2
13	<i>GBBG025153</i>	<i>G-VAR BOTTOM PIN V2</i>	2
14	GB500400008Z	COUNTERSUNK WASHER	4
15	GB900710025Z	SCREW M10X25	10
16	GB500100125	PIN 300X 95L	2
17	GB022400210	RUBBER PAD	2
18	GB022400208Z	CLUTCH	2
19	GB022400209V	SPRING RETAINER	2
20	GB919900043V	G-VAR RAM SPRING (LARGE)	4
21	<i>GB905400020</i>	<i>M24 (FINE) NYLOC NUT (ZINC)</i>	2
22	GB500100131Z	ROD	2
23	<i>GBBG026447</i>	<i>G-VAR RAM SPRING (SMALL)</i>	2
32	<i>GB905220024Z</i>	<i>M24 NUT (ZINC)</i>	2
33	GB920100034Z	M24 BALL JOINT	2
34	GB500400004Z	COUNTERSUNK WASHER	4
35	GB500100086	PIN	2
36	GB500200028Z	SPACER	4
37	<i>GBBG024772</i>	<i>HYDRAULIC RAM</i>	2
38	<i>GBBG024776</i>	<i>SEAL KIT</i>	2
39	GB003273	SPACER NUT M27	2
40	GB570500010Z	NIPPLE 1/4 BSP 1.0 ORIFICE	8
41	<i>GBBB50243113</i>	<i>COPPER WASHER</i>	8
42	GB500100055V	PIN	2
43	GB905220027Z	M27 PLAIN NUT (ZINC)	4
44	GB920100043Z	M27 BALL JOINT	4
45	<i>GB919800020</i>	<i>GREASE NIPPLE</i>	16
46	GB006461	LINK ARM OUTER FOLD	4
47	<i>GB023200216V</i>	<i>LINK ARM PIVOT</i>	2
48	GB006426	PIN	6
49	GB000187	CIRCLIP	12
50	GB500100110V	PIN	2
51	GB500100146V	PIN 28 2ND FOLD	2
52	GB905400024	M24 NYLOC NUT (ZINC)	2
53	<i>GB907025044Z</i>	<i>M24 WASHER (ZINC)</i>	2
54	GB900124050Z	SCREW	2
55	GB905200024Z	M24 PLAIN NUT (ZINC)	4
56	GB500200049	BUSH	2

Pos	Part No	Description	Qty
57	GB500100111Z	BREAKAWAY SHAFT	2
58	GB919900023Z	BREAKAWAY SPRING	2
59	GB500400019Z	WASHER	2
60	GB950200004	RUBBER STOPPER 20mm	2
60	GB950200001	RUBBER STOPPER 30mm	2
61	GB907108024Z	M8 X 24mm WASHER	4
62	<i>GB905400008</i>	<i>M8 NYLOC NUT (ZINC)</i>	4
63	<i>GB022400053V</i>	<i>WING SUPPORT MALE</i>	4
64	XBMBB32	32mm U BOLT (M10)	4
65	XBMBB	40mm U BOLT (M10)	4
66	<i>GB905400010</i>	<i>M10 NYLOC NUT (ZINC)</i>	32
67	<i>GB907010021Z</i>	<i>M10 WASHER (ZINC)</i>	32
68	<i>GB022400054V</i>	<i>WING SUPPORT FEMALE</i>	4
69	XBMBB50	50mm U BOLT (M10)	8
70	GBBG000022	HYDRAULIC RAM	2
71	GB996000418	SEAL KIT	2
72	GB570500011Z	NIPPLE	2
73	GB271600046V	INDICATOR LOCKING PLATE	2
74	GB271600045V	BOOM LEVEL INDICATOR	2
75	GB905100010Z	LOCKING NUT	4
76	<i>GB950200058</i>	<i>CABLE RETAINER</i>	12
77	<i>GB900306035Z</i>	<i>M6 x 35mm BOLT (ZINC)</i>	12
78	<i>GB905300006</i>	<i>M6 NYLOC NUT (ZINC)</i>	124
79	<i>GB950200059</i>	<i>CABLE RETAINER</i>	4
80	<i>GB900106016Z</i>	<i>M6 x 16mm BOLT (ZINC) 8.8</i>	8
81	<i>GB907106018Z</i>	<i>M6 x 18mm WASHER (ZINC)</i>	8
82	GB550700500	7 HOLE SPRAY TUBE	2
83	GB550600500	6 HOLE SPRAY TUBE	2
85	GB550700500	7 HOLE SPRAY TUBE	2
87	GB550600500	6 HOLE SPRAY TUBE	2
88	GB999900100	SPRAY TUBE SUPPORT KIT	26
89	<i>GB2018000418V</i>	<i>SPRAY TUBE BRACKET</i>	26
90	<i>GB500500004Z</i>	<i>SPRAY TUBE U BOLT</i>	26
91	A425130	SPRAY TUBE 2 PIECE CLAMP	26
92	<i>GB904506040X</i>	<i>M6 x 40mm SCREW STAINLESS</i>	52
93	<i>GB905400006X</i>	<i>M6 NYLOC NUT STAINLESS</i>	52
98	<i>GB900110020Z</i>	<i>M10 x 20mm BOLT (ZINC)</i>	2
99	<i>GBBG027432</i>	<i>BUSH</i>	2

NOTE

Parts in italics are non-stock items and may need to be ordered.

GBCOMPL-30C - Centre Section 30m Assembly Drawings & Parts

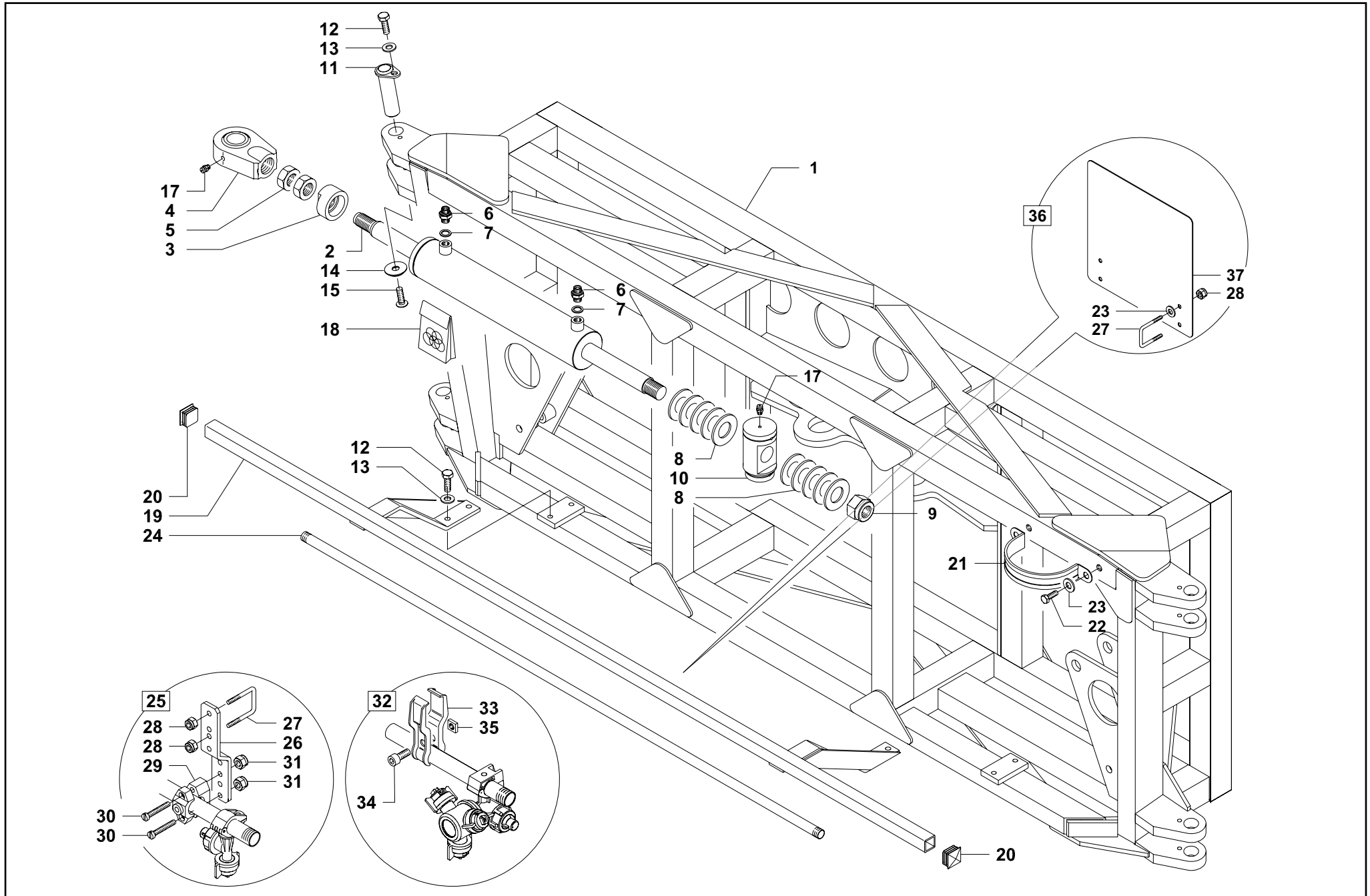

Section 7

GBCOMPL-30C - Centre Section 30m

Pos	Part No	Description	Qty
1	<i>GBBG001108</i>	<i>30m CENTRE SECTION</i>	1
2	GB703570018V	HYDRAULIC RAM	2
3	GB500300032V	M30 SPACER NUT	2
4	GBBG001752	M30 BALL JOINT	2
5	GB905215028Z	M30 LOCK NUT	4
6	GB570500011Z	1/4" NIPPLE 1.5 ORIFICE	4
7	GB600500001	COPPER WASHER	4
8	GB913671040	BELLVILLE WASHER	152
9	GB905420030	M30 NYLOC NUT (ZINC)	2
10	<i>GB500100127Z</i>	<i>CYLINDER MOUNT</i>	2
11	GBBG000024	PIN	4
12	GB900110025Z	M10 x 20mm BOLT (ZINC)	8
13	GB907200010Z	10mm SPRING WASHER	8
14	GB500400004Z	COUNTERSUNK WASHER	4
15	GB900710025Z	COUNTERSUNK SCREW	4
17	<i>GB919800020</i>	<i>GREASE NIPPLE</i>	4
18	GB000117	SEAL KIT	1
19	<i>GB201800415V</i>	<i>C/SEC RAIL MOUNT BRACKET</i>	1
20	GB950130030	END CAP	2
21	<i>GB950200059</i>	<i>CABLE RETAINER</i>	2
22	<i>GB900100016Z</i>	<i>M6 x 16mm BOLT (ZINC) 8.8</i>	8
23	<i>GB907106018Z</i>	<i>M6 x 18mm WASHER (ZINC)</i>	8
24	GB550500500	5 HOLE SPRAY RAIL	1
25	GB999900100	SPRAY RAIL MOUNT KIT	3
26	<i>GB201800418V</i>	<i>SPRAY RAIL MOUNT BRACKET</i>	3
27	<i>GB500500004Z</i>	<i>M6 U BOLT</i>	3

Pos	Part No	Description	Qty
28	<i>GB905300006</i>	<i>M6 NYLOC NUT (ZINC)</i>	6
29	A425130	2 PIECE RAIL CLAMP	3
30	<i>GB904506040X</i>	<i>M6 x 40mm SCREW STAINLESS</i>	6
31	<i>GB905400006X</i>	<i>M6 NYLOC NUT STAINLESS</i>	6
36	<i>GB999900467</i>	<i>WARNING LABEL PLATE KIT</i>	1
37	<i>GB201800065V</i>	<i>WARNING LABEL PLATE</i>	1

NOTE

Parts in italics are non-stock items and may need to be ordered.

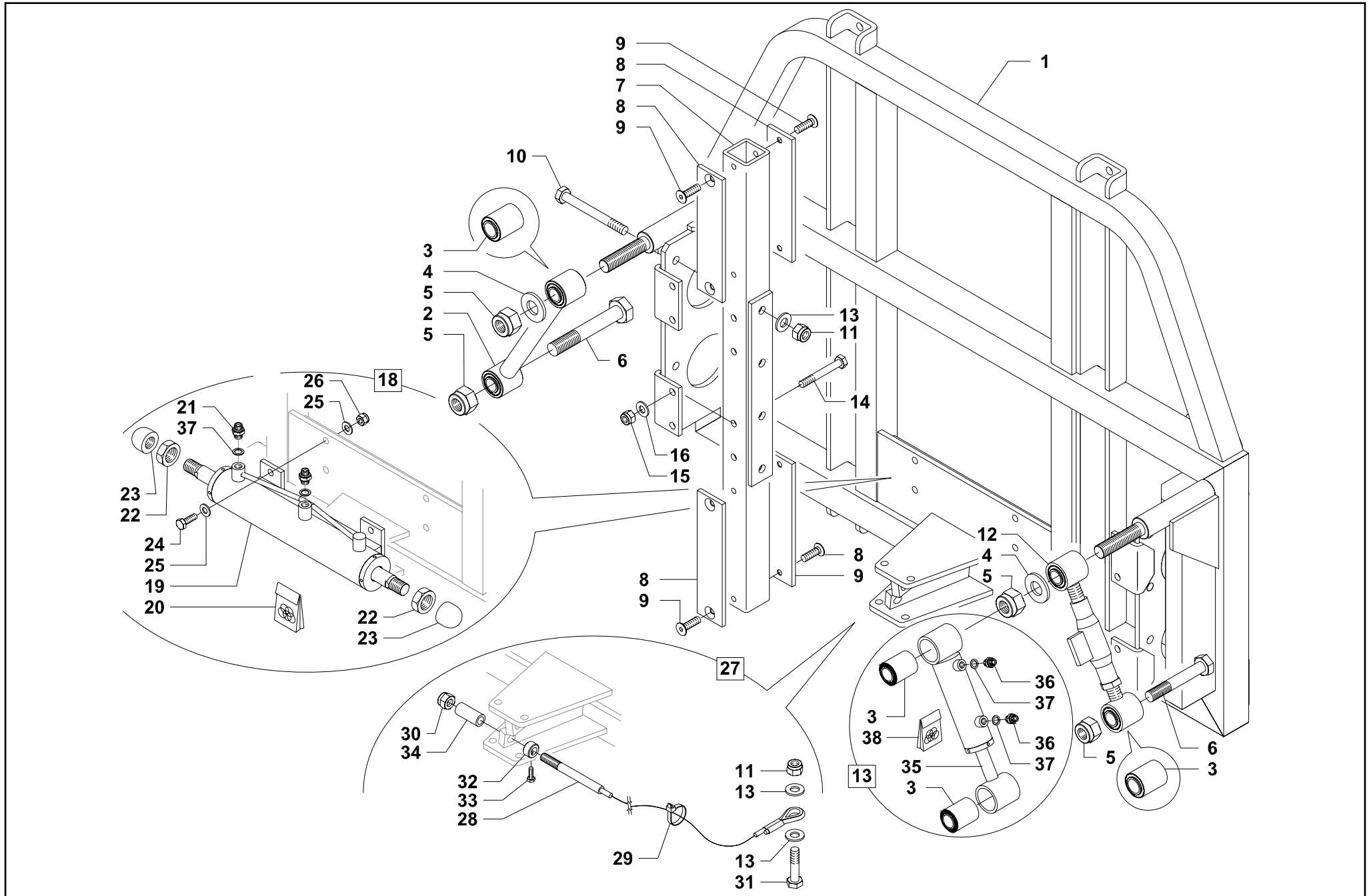

Section 7

GBCOMPL-30C - Centre Section 30m

Pos	Part No	Description	Qty
1	GB382000050V	SELF LEVELLING FRAME	1
2	GB993806001V	TIE ROD ASSY.	2
3	GB950300004	FLEXIBLE BUSH	4
4	GB500400019Z	M24 WASHER	4
5	GB905400024	M24 NYLOC NUT	4
6	<i>GB900324130Z</i>	<i>M24 x130mm BOLT (ZINC) 8.8</i>	2
7	GB382000075V	WEAR PAD BRACE	2
8	GB382000078	WEAR PAD	8
9	GB900710025Z	COUNTERSUNK SCREW	16
10	<i>GBBG001401</i>	<i>M14 x 100mm BOLT (ZINC) 8.8</i>	8
11	<i>GB905300014</i>	<i>M14 NYLOC NUT (ZINC)</i>	12
12	GB993806002Z	ADJUSTABLE TIE ROD ASSY.	1
13	GB907014028Z	M14 WASHER (ZINC)	12
14	<i>GB900312090Z</i>	<i>M12 x 90 BOLT (ZINC) 8.8</i>	8
15	<i>GB905300012</i>	<i>M12 NYLOC NUT (ZINC)</i>	8
16	GB907012025Z	M12 WASHER (ZINC)	16
18	GB997000018	LOCK RAM KIT	1
19	<i>GB702550023V</i>	<i>LOCK RAM</i>	1
20	<i>GB996000179</i>	<i>SEAL KIT</i>	1
21	GB570500011Z	1/4" NIPPLE 1.5 ORIFICE	2
22	GB905200022Z	M22 NUT	2
23	GB501100007	LOCKING RAM END PIECE	2
24	<i>GB900510035Z</i>	<i>M10 x25mm BOLT (ZINC) 8.8</i>	4
25	<i>GB907010021Z</i>	<i>M10 WASHER (ZINC)</i>	8
26	<i>GB905300010</i>	<i>M10 NYLOC NUT (ZINC)</i>	4
27	<i>GBBG001395</i>	<i>STRAINER WIRE KIT</i>	1

Pos	Part No	Description	Qty
28	GB500700069	STRAINER WIRE	2
29		CABLE TIE	8
30	GB905415014	M14 NUT FINE THREAD (1.5)	2
31	<i>GB900314060Z</i>	<i>M14 x 60mm BOLT (ZINC) 8.8</i>	2
32	<i>GB919800061Z</i>	<i>LOCKING COLLAR</i>	2
33	<i>GB900106010Z</i>	<i>M6 x20mm BOLT (ZINC)</i>	2
34	<i>GBBG001396</i>	<i>SPACER</i>	2
35	GB702550031V	TILT CYLINDER	1
36	GB570500007Z	1/4" NIPPLE 0.7 ORIFICE	2
37	GB600500001	COPPER WASHER	4
38	<i>GB996000192</i>	<i>SEAL KIT</i>	1

NOTE

Parts in italics are non-stock items and may need to be ordered.

GBCOMPL-305-LHA or RHA - Boom Non Gvar & Gvar 30m Assembly Drawings & Parts

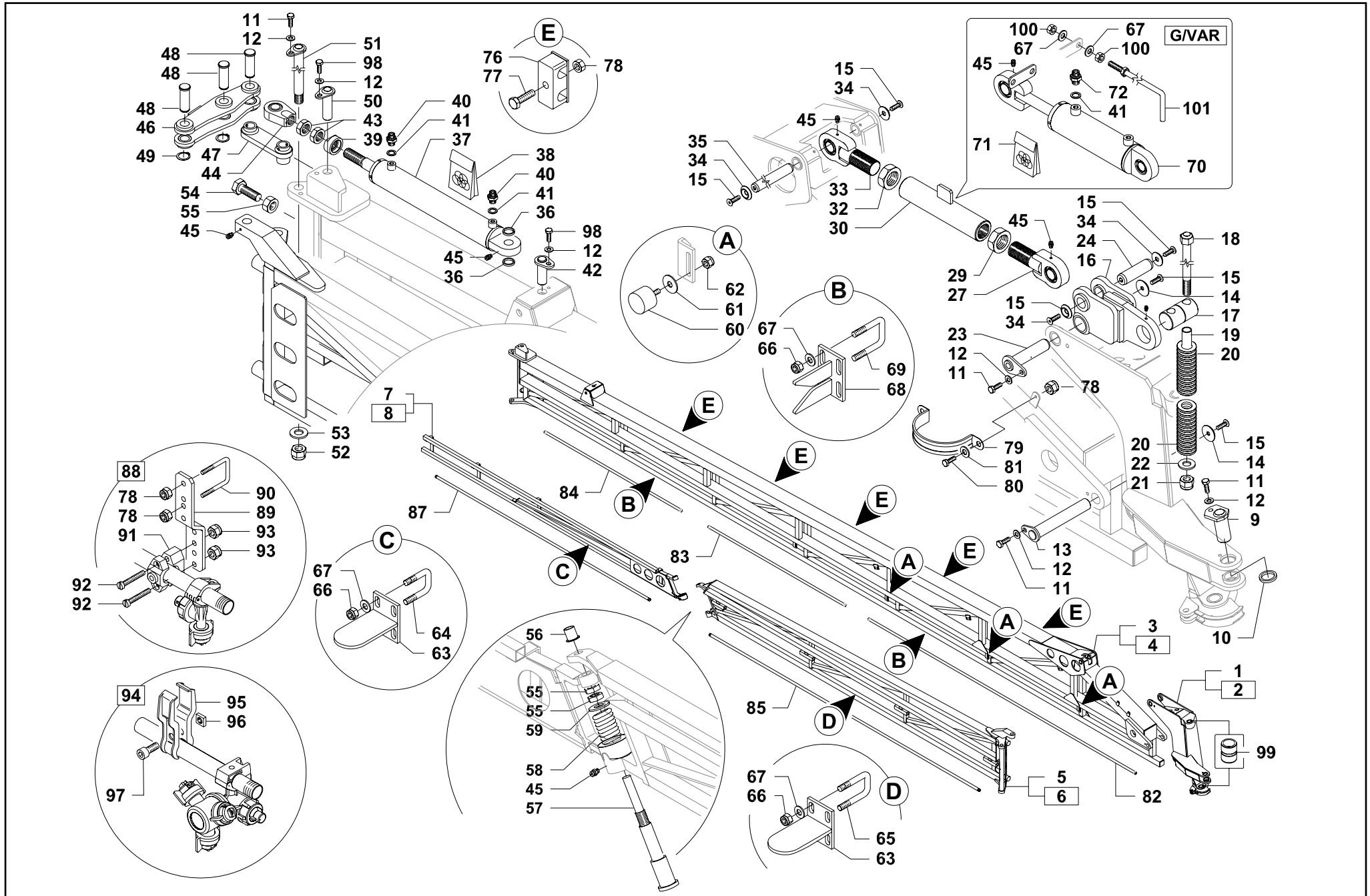

Section 7

GBCOMPL-305-LHA or RHA - Boom Non Gvar & Gvar 30m

Pos	Part No	Description	Qty
1	GBBG026414	INNER PIVOT R/H V2	1
2	GBBG026415	INNER PIVOT L/H V2	1
3	GBBG025150	INNER BOOM ARM R/H V2	1
4	GBBG025151	INNER BOOM ARM L/H V2	1
5	GB023000050V	OUTER BOOM ARM R/H	1
6	GB023000051V	OUTER BOOM ARM L/H	1
7	GB022800080V	BREAKAWAY ARM R/H	1
8	GB022800081V	BREAKAWAY ARM L/H	1
9	GB392000330V	PIN	2
10	GB392000335Z	SPACER	2
11	GB900110025Z	M10 x 20mm BOLT (ZINC) 8.8	10
12	GB907200010Z	10mm SPRING WASHER	12
13	GB500100144VR	BOTTOM PIN	2
14	GB500400008Z	COUNTERSUNK WASHER	4
15	GB900710025Z	COUNTERSUNK SCREW	12
16	GBBG006429	PIN HOUSING	2
17	GB500100145Z	STRAINER PIN	2
18	GB023200209Z	STRAINING BOLT	2
19	GB500200037Z	SLEEVE	2
20	GB919900043V	SPRING	4
21	GB905400020	M30 NYLOC NUT (ZINC)	2
22	GB907120046Z	M30 WASHER (ZINC)	2
23	GB500100058V	PIN	2
24	GB500100044	PIN	2
27	GBBG017659	L/H BALL JOINT	2
29	GBBG017662	M30 NUT L/H THREAD	2
30	GBBG017657	DUAL THREADED TURNBUCKLE	2
32	GBBG017660	M30 NUT R/H THREAD	2
33	GBBG017658	R/H BALL JOINT	2
34	GB500400004Z	COUNTERSUNK WASHER	8
35	GBBG006427	PIN	2
36	GB500200029Z	SPACER	4
37	GBBG024772	HYDRAULIC RAM	2
38	GBBG024776	SEAL KIT	2
39	GB003273	M27 SPACER LOCK NUT	2
40	GB570500010Z	1/4" NIPPLE 1.0 ORIFICE	4
41	GB600500001	COPPER WASHER	6*
42	GB500100055V	PIN	2
43	GB905220027Z	M27 PLAIN NUT (ZINC)	4
44	GB920100043Z	BALL JOINT M27	2
45	GB919800020	GREASE NIPPLE	14*
46	GB006461	LINK ARM	4
47	GB023200216V	LINK PIVOT	2
48	GB006426	PIN	6
49	GB000187	CIRCLIP	6
50	GB500100110V	PIN	2
51	GB500100146V	PIN	2
52	GB905400024	M24 NYLOC NUT (ZINC)	2
53	GB907025044Z	M24 WASHER (ZINC)	2

Pos	Part No	Description	Qty
54	GB900124050Z	M24 BOLT	2
55	GB905200024Z	M24 PLAIN NUT (ZINC)	6
56	GB500200049	CAP WASHER	2
57	GB500100111Z	BREAKAWAY PIN	2
58	GB919900023Z	BREAKAWAY SPRING	2
59	GB500400019Z	M24 WASHER (LARGE)	2
60	GB950200004	RUBBER STOPPER 20mm	4
60	GB950200001	RUBBER STOPPER 30mm	2
61	GB90710824Z	M8 X 24mm WASHER	6
62	GB905400008	M8 NYLOC NUT (ZINC)	6
63	GB022400053V	WING SUPPORT MALE	2
64	XBMBB32	32mm U BOLT	4
65	XBMBB	40mm U BOLT	4
66	GB905400010	M10 NYLOC NUT (ZINC)	16
67	GB907010021Z	M10 WASHER (ZINC)	18*
68	GB022400054V	WING SUPPORT FEMALE	2
69	XBMBB50	50mm U BOLT	8
70	GBBG006474	GVAR RAM	2
70	MP-610/30-2	LOCK VALVE KIT FOR GVAR RAM	2
71	GB996000418	SEAL KIT	2
72	GB570500011Z	1/4" NIPPLE 1.5 ORIFICE	2
76	GB950200058	HOSE RETAINER	10
77	GB900306035Z	M6 x 35mm BOLT (ZINC)	10
78	GB905300006	M6 NYLOC NUT (ZINC)	66
79	GB950200059	CABLE RETAINER	2
80	GB900106016Z	M6 x 35mm BOLT (ZINC)	4
81	GB907106018Z	M6 NYLOC NUT (ZINC)	4
82/83	GB550400500	4 HOLE SPRAY RAIL	4
84/85	GB550700500	7 HOLE SPRAY RAIL	4
87	GB550600500	6 HOLE SPRAY RAIL	2
88	GB999900100	SPRAY RAIL SUPPORT KIT	26
89	GB201800418V	SPRAY RAIL BRACKET	26
90	GB500500004Z	M6 U BOLT	26
91	A425130	2 PIECE RAIL CLAMP	26
92	GB904506040X	M6 x 40mm SCREW STAINLESS	52
93	GB905400006X	M6 NYLOC NUT STAINLESS	52
98	GB900110020Z	BOLT	2
99	GBBG000067	BUSHING	2
100	GB905100010Z	M10 PLAIN NUT (ZINC)	4
101	GB27160045V	LEVELLER SIGHT GAUGE	2

* Quantities may vary between Gvar and Standard Booms

NOTE

Parts in italics are non-stock items and may need to be ordered.

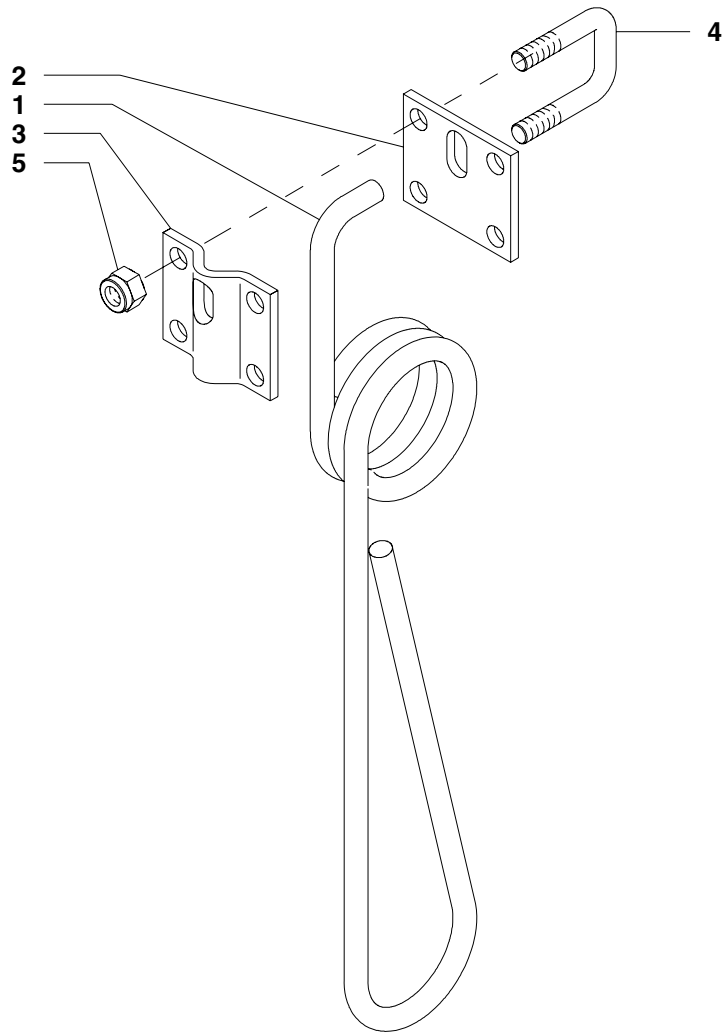

Pos	Part No	Description	Qty
1	GG919900030V		
2	GG501100008V		
3	GG501100009V		
4	GG500500003Z		

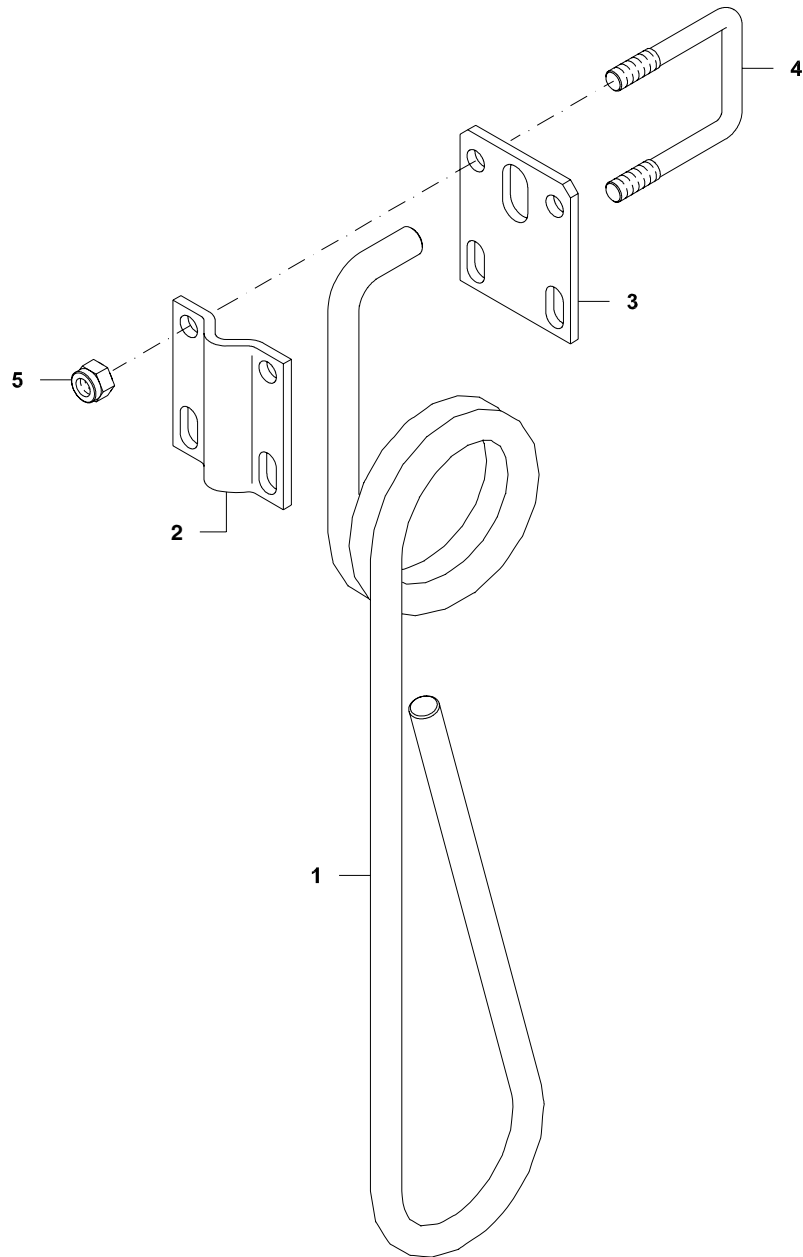

Pos	Part No	Description	Qty
1	BG016220		
2	BG016280		
3	BG016282		
4	GG500500002Z		
5	GG905400010		

AB19100-AA - 33/36m - Centre Section/Hanger V2 Assembly Drawings & Parts

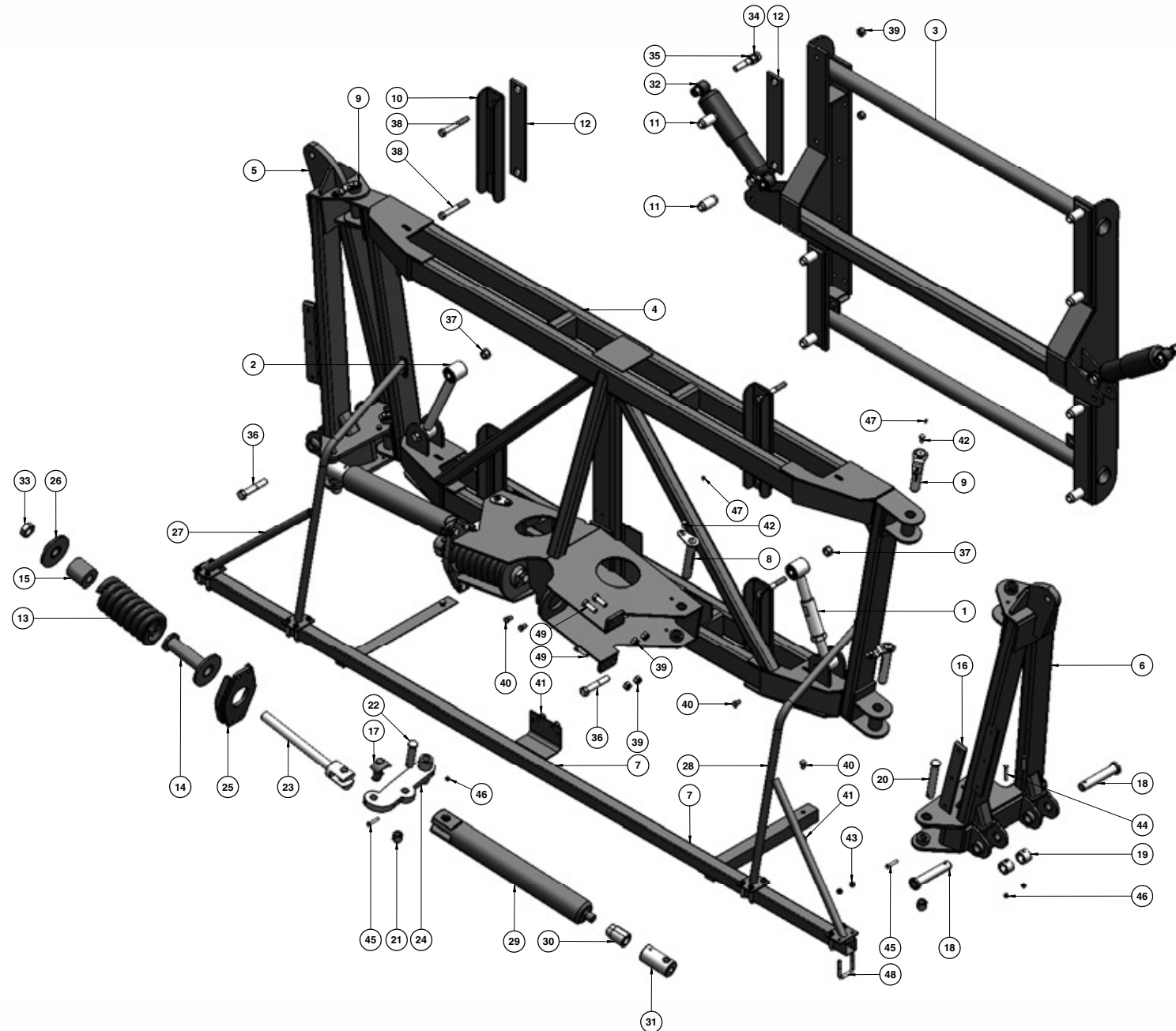

Section 7

AB19100-AA - 33/36m - Centre Section/Hanger V2

Pos	Part No	Description	Qty
1	AB191-100	SELF LEVELLER ADJUSTER	1
2	AB191-101	SELF LEVELLER FIXED ARM	1
3	AB19101	CENTRE SECTION HANGER	1
4	AB19102A	CENTRE SECTION MAIN FRAME	1
5	AB19103BL	INNER FOLD PIVOT L.H.	1
6	AB19103BR	INNER FOLD PIVOT R.H.	1
7	AB19108	CENTRE SPRAY BAR SUPPORT	1
8	AB19120A	PIN Z BAR PIVOT	2
9	AB19120	INNER FOLD PIVOT PIN	4
10	AB19121	WEAR PAD SUPPORT	4
11	AB19122	WEAR PAD SPACER	8
12	AB19123	WEAR PAD SELF LEVELLER	8
13	AB19127	SPRING YAW CENTRE FRAME	2
14	AB19131A	SPRING BUFFER HOLDER	2
15	AB19131A-1	BUFFER POLY URETHANE	2
16	AB19143	BOOM FOLD STOP PAD	2
17	AB19156C	CYLINDER CLEVIS BOOM PIN VER 2	2
18	AB19183-130	PIN FIRST ARM 164 X 30	4
19	AB19183-2	COLLAR DIA 30MM	4
20	AB19184-125	PIN FOLD CYLINDER 155 X 25.4	2
21	AB19184-2	COLLAR DIA 25.4MM	4
22	AB19184-70	PIN FOLD CYLINDER 100 X 25.4	2
23	AB19191B	PIN YAW SPRING CLEVIS END	2
24	AB19192F	INNER FOLD Z BAR	2
25	AB19193	YAW SPRING CLAMP	2
26	AB19194A	SPRING BUFFER HOLDER	2
27	AB19195L	BOOM PROTECTION L.H.	1
28	AB19195R	BOOM PROTECTION R.H.	1

Pos	Part No	Description	Qty
29	AB19199	CYLINDER INNER FOLD 3" X 16" EZFIT	2
30	AB19199-M	ROD END MALE INNER FOLD CYLINDER	2
31	AB19199-F	ROD END FEMALE INNER FOLD CYLINDER	2
32	BP-607	SHOCK ABSORBER AIR RIDE P126	2
33	1.25NNUTUNF	1 1/4" UNF LOCK NUT	2
34	0.75X100UNCBOLT	3/4" X 4" UNC BOLT HT ZP	4
35	0.75UNCNNUT	3/4" UNC NYLOC NUT HT ZP	6
36	M20X110BOLT	M20 X 110 HEX HEAD BOLT HT ZP	4
37	M20NNUT	M20 NYLOC NUT HT ZP	4
38	M16X120BOLT	M16 X 120 HEX HEAD BOLT HT ZP	8
39	M16NNUT	M16 NYLOC NUT HT ZP 1	6
40	M12X20	M12 X 20 HEX HEAD SET SCREW HT ZP	6
41	M12NNUT	M12 NYLOC NUT HT ZP	4
42	M10X20	M10 X 20 SET SCREW HT ZP	6
43	M10NNUT	M10 NYLOC NUT HT ZP 1	6
44	M8X55BOLT	M8 X 55 HEX HEAD BOLT HT ZP	4
45	M8X45BOLT	M8 X 45 HEX HEAD BOLT HT ZP	4
46	M8NNUT	M8 NYLOC NUT HT ZP	8
47	M6GNIPPLE	M6 GREASE NIPPLE	6
48	XBMBB50	U-BOLT 50MM X 10	8
49	M16X45	M16 X 45 HEX HEAD SET SCREW HT ZP	8

NOTE

Parts in italics are non-stock items and may need to be ordered.

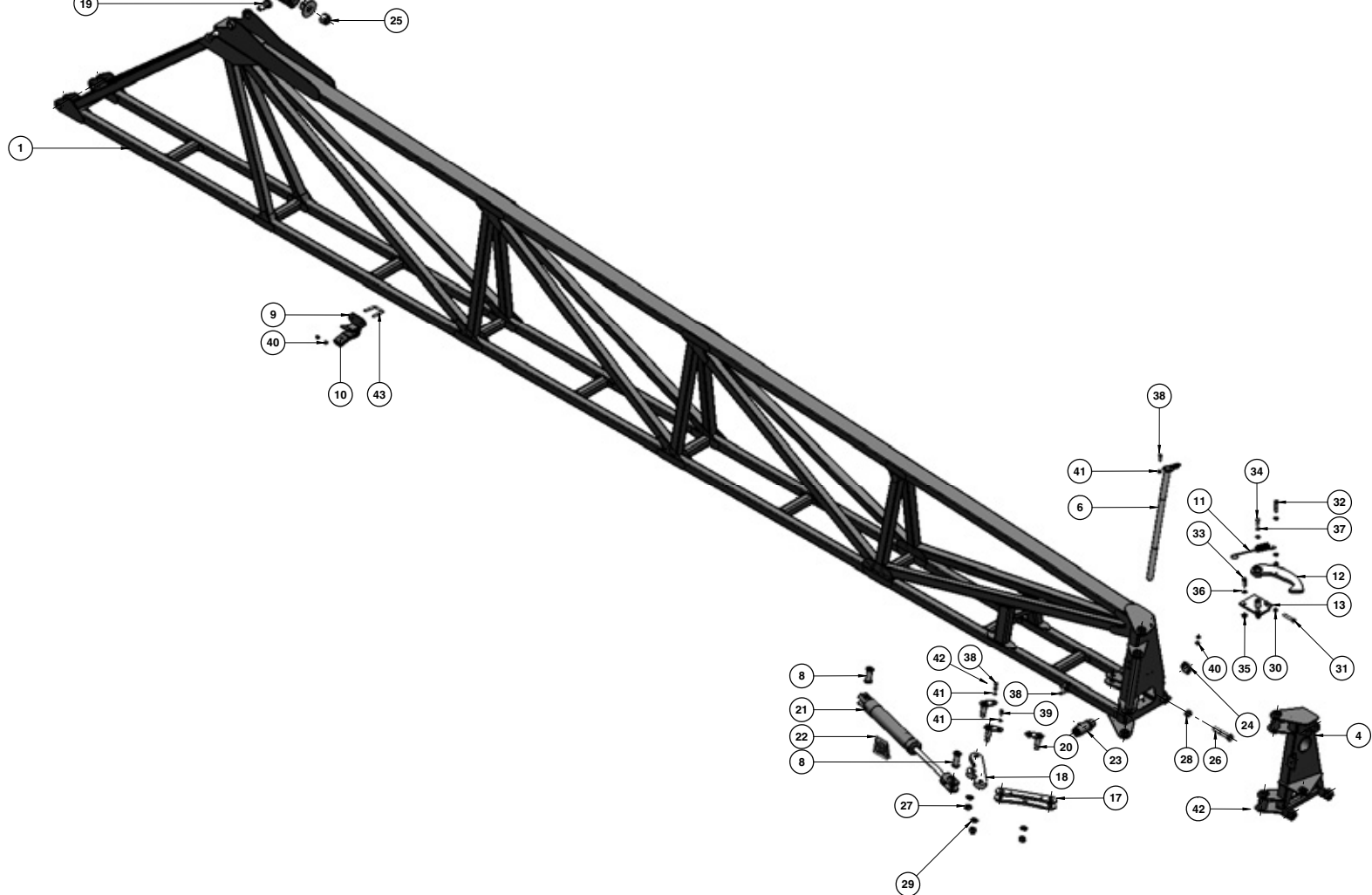
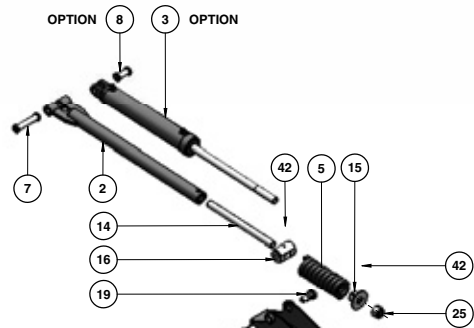

PART NUMBER	DESCRIPTION
AB19100-BR-33	33M RIGHTHAND BOOM ARM COMPLETE
AB19100-BR-36	36M RIGHTHAND BOOM ARM COMPLETE
AB19100-BL-33	33M LEFTHAND BOOM ARM COMPLETE
AB19100-BL-36	36M LEFTHAND BOOM ARM COMPLETE

Section 7

Complete Left/Right Boom Arm 33/36m

Pos	Part No	Description	Qty
1	AB19107R	FIRST ARM R.H. 33/36M	1
	AB19107L	FIRST ARM L.H. 33/36M	1
2	AB19100-A-2	FIXED WINGTIP ADJUSTMENT	1
3	AB19100-A-3	HYDRAULIC WINGTIP ADJUSTMENT	1
4	AB19113CR	FOLD PIVOT OUTER R.H.	1
	AB19113CL	FOLD PIVOT OUTER L.H.	1
5	AB19135	PIN 36M 1ST ARM TO 2ND	1
6	AB19150-130	PIN 130 X 30	1
7	AB19150-65	PIN 65 X 25.4	3
8	AB19157A	BRACKET OUTER BOOM	1
9	AB19157Apad	PAD OUTER BOOM SUPPORT	1
10	AB19159	SPRING LOCK ARM	1
11	AB19160R	ARM HINGE LOCK R.H.	1
	AB19160L	ARM HINGE LOCK L.H.	1
12	AB19161R	PLATE HINGE LOCK RH	1
	AB19161L	PLATE HINGE LOCK L.H.	1
13	AB19163	ROD G-FIX	1
14	AB19164	SPRING RETAINER PLATE	1
15	AB19165	PIVOT BLOCK	1
16	AB19178	ARM FOLD PIVOT OUTER	1
17	AB19179	LINK PLATE OUTER FOLD RAM	1
18	AB19180	PIN PIVOT BLOCK	2
19	AB19181	PIN OUTER FOLD SCISSOR JOINT	3
20	AB19197	CYLINDER OUTER FOLD 3.5 X 12	1
21	AB19197-SK	SEAL KIT HP-016 CYLINDER	1
22	AB20800	CYLINDER FOLD LOCK 35 X 38.1	1
23	AB20800-1	LOCK NUT 1 1/4" BSP	1
24	1.25UNFNUT	1 1/4" UNF NYLOC NUT	1

Pos	Part No	Description	Qty
25	M20X100BOLT	M20 X 100 HEX HEAD BOLT HT ZP	1
26	M20NNUT	M20 NYLOC NUT HT ZP	3
27	M20HNUT	M20 HALF NUT ZP	1
28	M20FWASHER	M20 FLAT WASHER ZP	3
29	M12HNUT	M12 HEX NUT HT ZP	2
30	M12X70	M12 X 70 SET SCREW HT ZP	1
31	M12X60BOLT	M12 X 60 BOLT HT ZP	1
32	M12X40	M12 X 40 SET SCREW HT ZP	3
33	M12X25	M12 X 25 SET SCREW HT ZP	1
34	M12NNUT	M12 NYLOC NUT HT ZP	3
35	M12FWASHER	M12 FLAT WASHER ZP	12
36	M12SWASHER	M12 SPRING WASHER ZP	1
37	M10X30	M10 X 30 SET SCREW HT ZP	4
38	M10X20	M10 X 20 SET SCREW HT ZP	2
39	M10NNUT	M10 NYLOC NUT HT ZP	6
40	M10FWASHER	M10 FLAT WASHER ZP	8
41	M6GNIPPLE	M6 GREASE NIPPLE	11
42	XBMBB50	U-BOLT 50MM X 10	1

NOTE

Parts in italics are non-stock items and may need to be ordered.

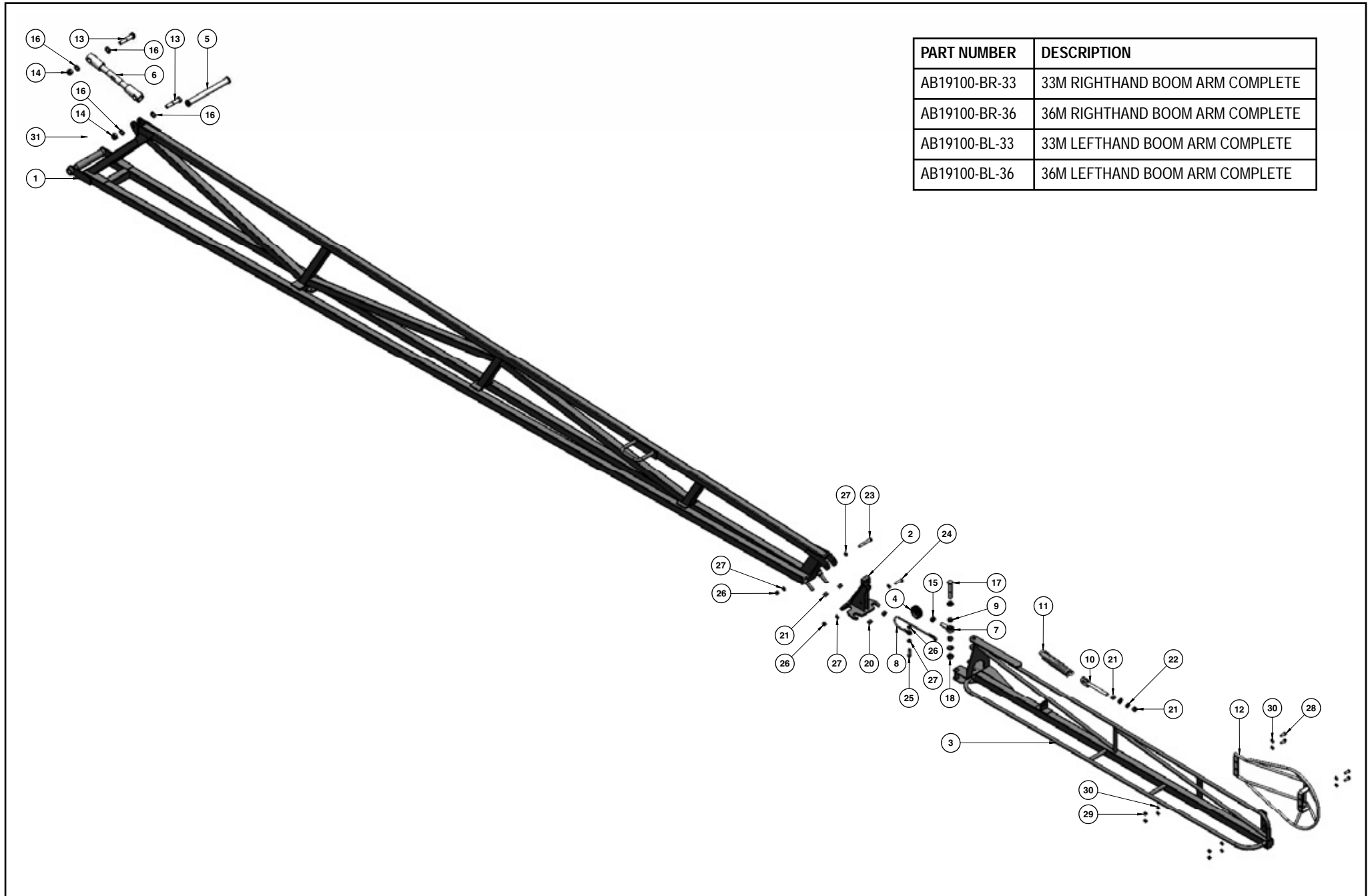

Section 7

Complete Left/Right Boom Arm 33/36m

Pos	Part No	Description	Qty
1	AB19109AL	BOOM ARM OUTER LH 36M	1
	AB19109AR	BOOM ARM OUTER RH 36M	1
	AB19110L	BOOM ARM OUTER LH 33M	1
	AB19110R	BOOM ARM OUTER LH 33M	1
2	AB19111A	BREAK-AWAY HITCH	1
3	AB19106AL	BREAK-AWAY TIP	1
4	AB19126-5	PULLEY	1
5	AB19152-330A	PIN OUTER BOOM SUPPORT	1
6	AB21200A	TOP LINK ADJUSTMENT	1
	AB21200A-1	BUSH	2
7	AB19126-4	MALE ROD END	1
8	AB19126-6	CABLE, PULLEY	1
9	AB19126-7	SPACER BUSH	2
10	MP-413	ADJUSTABLE SPRING HITCH	1
11	MP-519	SPRING	1
12	MP-598A	PROTECTION BRACKET FENCELINE V2	1
13	0.75X100UNCBOLT	3/4" X 4" UNC BOLT HT ZP	2
14	0.75UNCNNUT	3/4" UNC NYLOC NUT HT ZP	2
15	0.75UNFHNNUT	3/4" UNF HEX HALF NUT	1
16	0.75FWASHER	3/4" FLAT WASHER ZP	4
17	M20X100BOLT	M20 X 100 HEX HEAD BOLT HT ZP	1
18	M20NNUT	M20 NYLOC NUT HT ZP	1
19	M20FWASHER	M20 FLAT WASHER ZP	2
20	M16NNUT	M16 NYLOC NUT HT ZP	2
21	M16HNUT	M16 HEX NUT HT ZP	4
22	M16FWASHER	M16 FLAT WASHER ZP	2
23	M12X90	M12 X 90 BOLT HT ZP	1
24	M12X50	M12 X 50 SET SCREW HT ZP	1
25	M12X40	M12 X 40 HEX HEAD SET SCREW HT ZP	1
26	M12NNUT	M12 NYLOC NUT HT ZP	3
27	M12FWASHER	M12 FLAT WASHER ZP	7
28	M10X30	M10 X 30 SET SCREW HT ZP	4
29	M10NNUT	M10 NYLOC NUT HT ZP	4

Pos	Part No	Description	Qty
30	M10FWASHER	M10 FLAT WASHER ZP	8
31	M6GNIPPLE	M6 GREASE NIPPLE	1
<div style="border: 1px solid black; border-radius: 10px; padding: 10px; margin: 10px auto; width: fit-content;"> <p style="text-align: center;"><i>NOTE</i></p> <p style="text-align: center;"><i>Parts in italics are non-stock items and may need to be ordered.</i></p> </div>			
AB19106A-(L or R)-KIT - Complete Breakaway Assembly			
2	AB19111A	BREAK-AWAY HITCH	1
3	AB19106AL	BREAK-AWAY TIP	1
4	AB19126-5	PULLEY	1
7	AB19126-4	MALE ROD END	1
8	AB19126-6	AB19126-6 CABLE, PULLEY	1
9	AB19126-7	SPACER BUSH	2
10	MP-413	ADJUSTABLE SPRING HITCH	1
11	MP-519	SPRING	1
15	0.75UNFHNNUT	3/4" UNF HEX HALF NUT	1
17	M20X100BOLT	M20 X 100 HEX HEAD BOLT HT ZP	1
18	M20NNUT	M20 NYLOC NUT HT ZP	1
20	M16NNUT	M16 NYLOC NUT HT ZP	2
21	M16HNUT	M16 HEX NUT HT ZP	4
22	M16FWASHER	M16 FLAT WASHER ZP	2
24	M12X50	M12 X 50 SET SCREW HT ZP	1
25	M12X40	M12 X 40 HEX HEAD SET SCREW HT ZP	1
26	M12NNUT	M12 NYLOC NUT HT ZP	3
27	M12FWASHER	M12 FLAT WASHER ZP	7
28	M10X30	M10 X 30 SET SCREW HT ZP	4
29	M10NNUT	M10 NYLOC NUT HT ZP	4
30	M10FWASHER	M10 FLAT WASHER ZP	8

AB19196 - 33/36m - Skid Complete Single Assembly Drawings & Parts

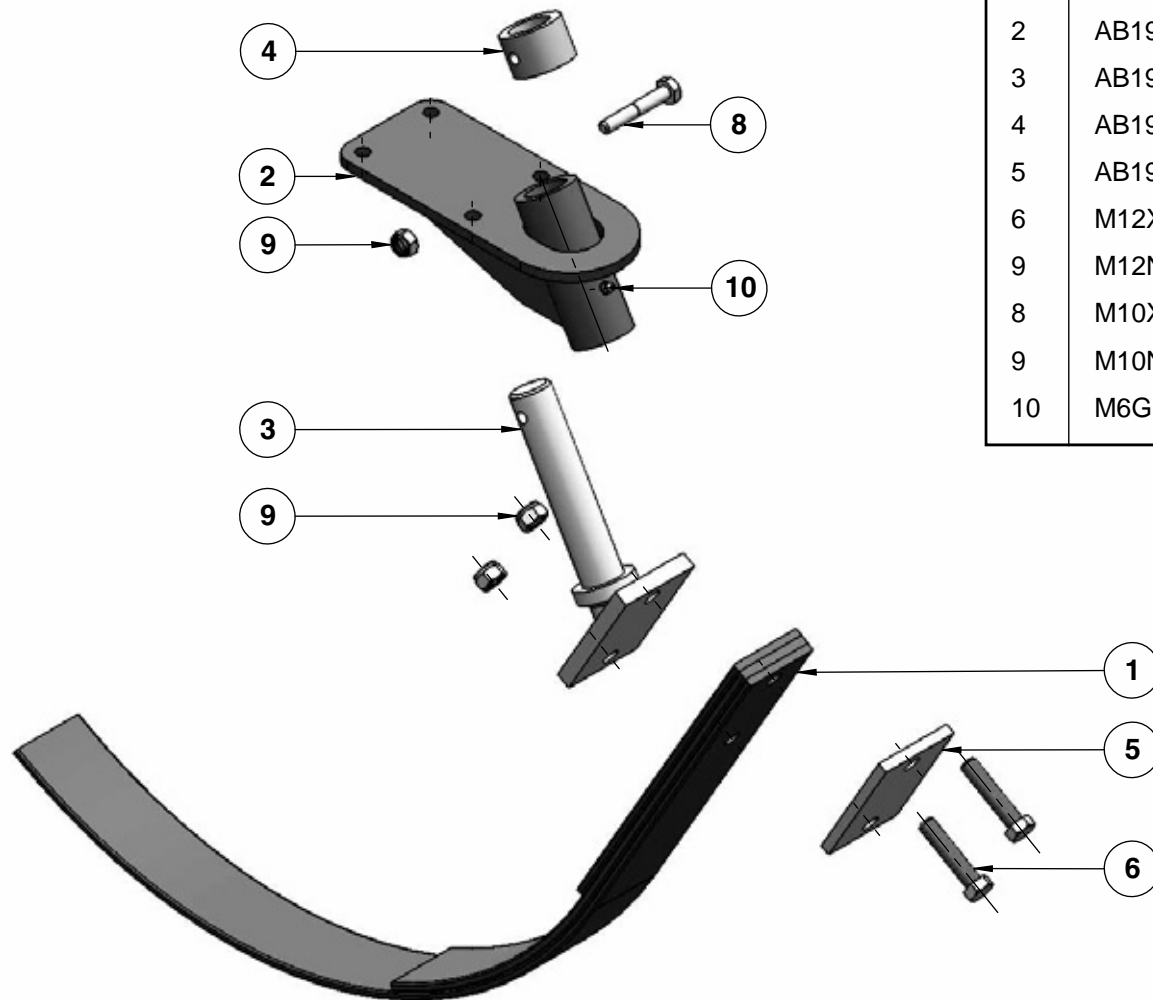

Pos	Part No	Description	Qty
1	AB19196-1	SKID SET 3 PIECE	1
2	AB19196-2	SKID MOUNT 36M BOOM FEMALE	1
3	AB19196-3	SKID MOUNT SHAFT AB191 BOOM	1
4	AB19196-4	COLLAR DIA 30MM	1
5	AB19196-6	SKID LEAF CLAMP	1
6	M12X55	M12 X 55 SET SCREW HT ZP	2
9	M12NNUT	M12 NYLOC NUT	2
8	M10X60BOLT	M10 X 60 BOLT HT ZP	1
9	M10NNUT	M10 NYLOC NUT HT ZP	1
10	M6GNIPPLE	M6 GREASE NIPPLE	1