

CROPLANDS

FL3501 Series (Triplex Pump)

3501 Triplex Pump

The new Triplex pump from Flojet has some unique features including: fully sealed motor for corrosion resistance, pressure switch & bypass, on/off switch on the housing, low pulsation & noise, superior pump head sealing, excellent priming capacity & compact size. For use in small boom of spot spraying, foam marking, silage treatment & many other agricultural applications.

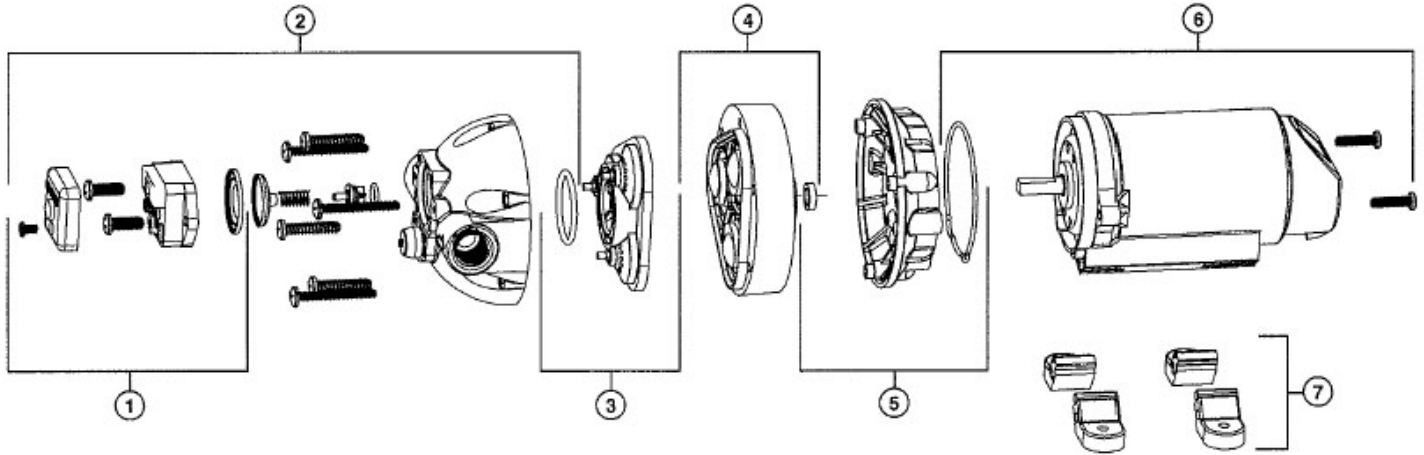

FL3501-503

Spare Part Description	Position	Part Number
Pressure Switch	1	FL02091-025
Diaphragms	N/A	N/A
Check Valves	3	FL20407-032