

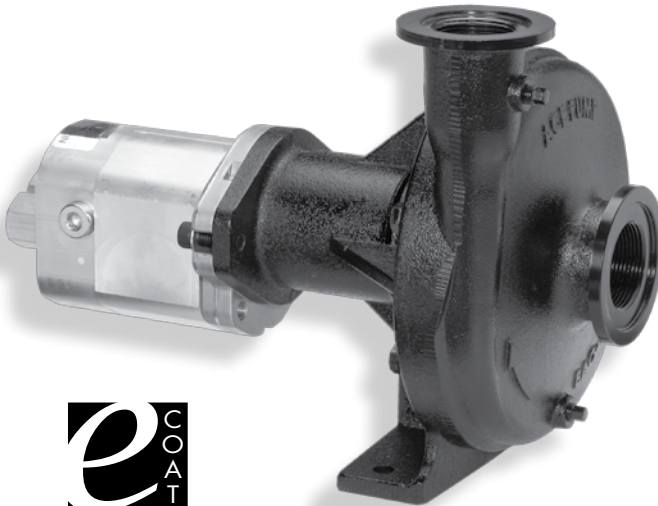

High Performance Hydraulic Motor Driven Centrifugal Pump

FMC-650F-HYD

- Suction 220 Flange & 1-1/2" NPT
- Discharge 200 Flange & 1-1/4" NPT
- High Performance Pump
 - Maximum Flow 170 GPM (644 LPM)
 - Maximum Pressure 160 PSI (11 BAR)
 - Modified Impeller Design for Higher Pressure at Lower RPM
- Maximum Reliability
 - Operates at Lower RPM for Longer Life
 - Oversized Bearings
 - E-coat Corrosion Protection
 - Stainless Steel Shaft with Splined Motor Connection
 - High Efficiency 4000 PSI (275 BAR) Pressure Plated Gear Motor



PERFORMANCE CHART

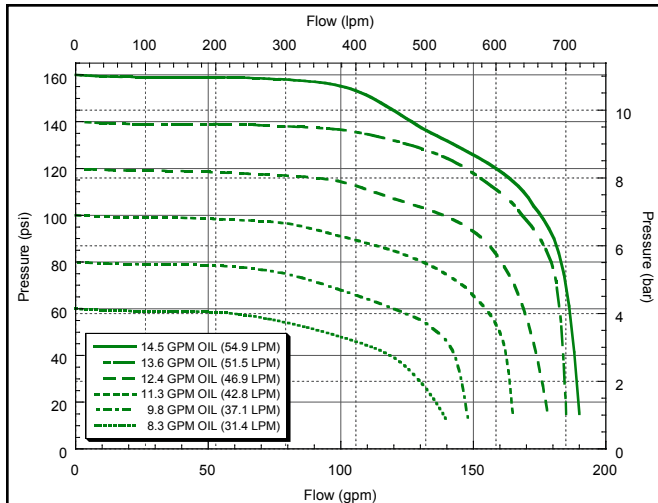

Note: Performance with flanged connections and full size plumbing.

DIMENSIONS

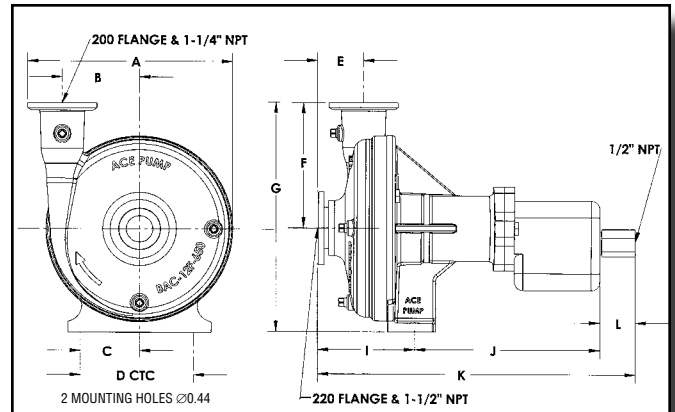

	A	B	C	D	E	F	G	I	J	K	L
INCHES	9.25	3.50	2.63	5.25	2.00	5.62	10.3	4.31	8.82	14.64	1.50
MM	235.0	88.9	66.8	133.3	50.8	142.8	261.6	109.5	224.0	371.9	38.1



FMC-650F-HYD

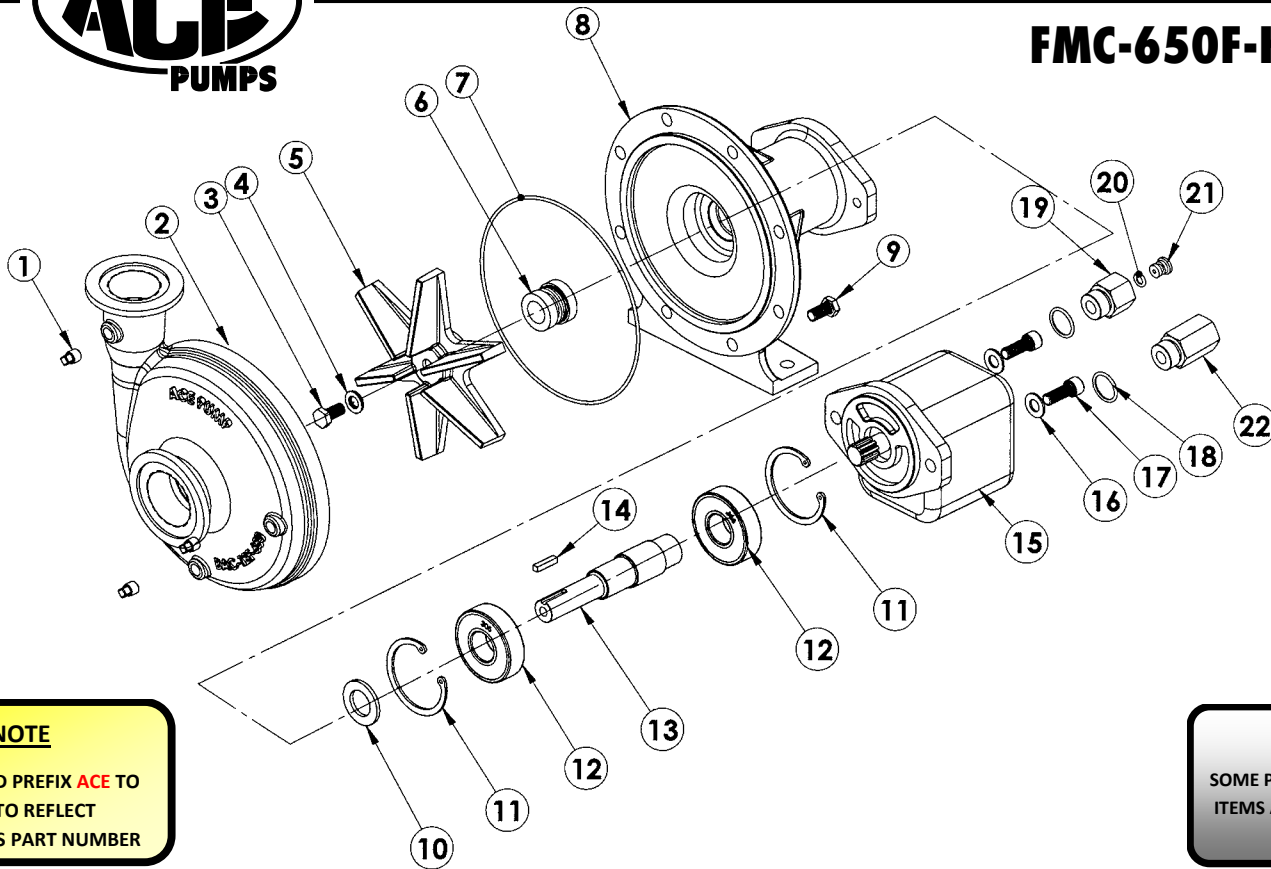

NOTE

PLEASE ADD PREFIX **ACE** TO
EDP# TO REFLECT
CROPLANDS PART NUMBER

NOTE

SOME PARTS ARE NON-STOCK
ITEMS AND MAY NEED TO BE
ORDERED

REF. #	PART NUMBER	EDP #	DESCRIPTION	REQ.
1	BAC-53	41110	Pipe plug, 1/8" NPT, square head	3
1	41120	41120	Pipe plug, 1/8" NPT, hex head, stainless steel (optional)	3
2	BAC-12-650-FLG	30159	Volute, NPT & 220 flange x NPT & 200 flange (F model)	1
3	40930	40930	Cap screw, 3/8" NC x 3/4" hex head, stainless steel	1
4①②	30029	30029	Washer, 3/8" O.D., sealing, stainless steel	1
5	BAC-26-650	30169	Impeller, cast iron, e-coated	1
6①	BAC-7-650	40145	Seal, carbon/ceramic/Viton®, 3/4"	1
6②	BAC-7SC-650	40146	Seal, silicon carbide/Viton®, 3/4" (optional)	1
6	BAC-7-650B	40144	Seal, carbon/ceramic/Buna N, 3/4" (for aqua ammonia)	1
7①②	BAC-4-150	40015	O-ring, volute seal	1
8	BAC-14-650-HYD	40325	Mounting frame, cast iron, e-coated	1
9	40950	40950	Cap screw, 3/8" NC x 3/4" hex head	8
9	40930	40930	Cap screw, 3/8" NC x 3/4" hex head, stainless steel (optional)	8
10	BAC-54-650	41132	Slinger, 1.5" OD x 7/8" ID	1
11	41943	41943	Snap ring, internal, mounting frame	2
12	40875	40875	Ball bearing, sealed	2
13	BAC-6-650-HYD-SS	40051	Shaft, 1.13" dia., 11T female spline, stainless steel	1
14	41085	41085	Key, .188 x .188 x .875, FMC-650 models	1
15	BAC-75-HYD-M16	41359	Motor, hydraulic, pressure plated gear	1
16	42701	42701	Washer, 3/8"	2
17	41907	41907	Cap screw, 3/8" NC x 1", socket head	2
18	41445	41445	O-ring, #10 SAE fitting	2
19	41446	41446	Body, adapter/restrictor, #10 SAE male x 1/2" NPT female	1
20	41448	41448	O-ring, restrictor insert	1
21	41447	41447	Restrictor orifice insert, .125	1
22	41442	41442	Reverse check, #10 SAE male x 1/2" NPT female	1
①	RK-FMC-650	52720	Repair kit, carbon/ceramic/Viton® seal, FMC-650 models	--
②	RK-FMCSC-650	52721	Repair kit, silicon carbide/Viton® seal, FMC-650 models	--

Viton® is a registered trademark of DuPont Dow Elastomers.