

9203 Cast Iron and Stainless Steel Series

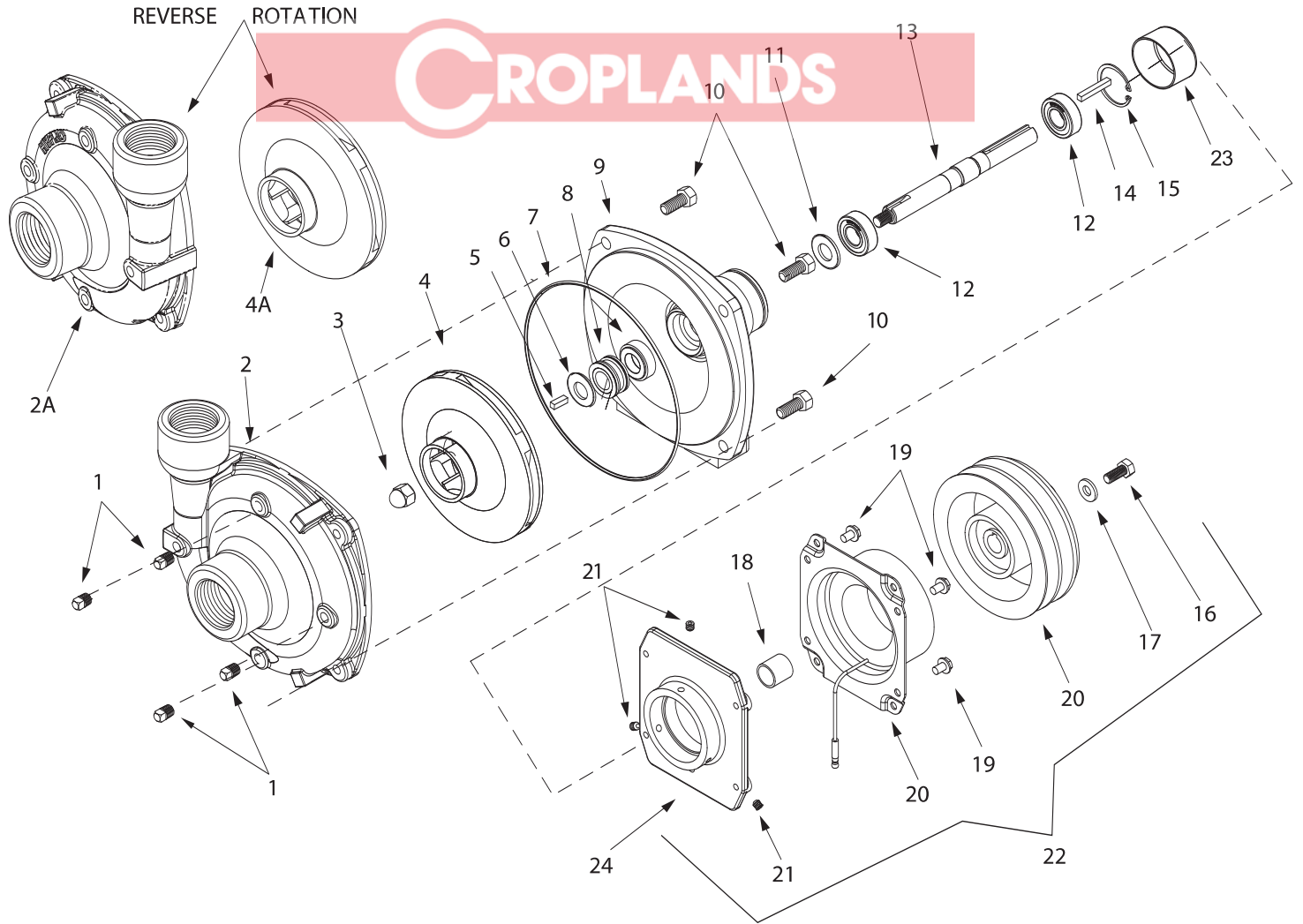

Seal Kit for Stainless Series:
No. 3430-0589 consists of:
(1) Ref. 7 O-Ring
(1) Ref. 8 Mechanical seal

Seal Kit for Cast Iron Series
No. 3430-0332 consists of:
(1) Ref. 7 O-Ring
(1) Ref. 8 Mech. seal
(1) Ref. 6 Gasket

Note: When ordering parts, give quantity, part number, description and complete model number. Reference numbers are used ONLY to identify parts in the drawing and NOT to be used as order numbers.

No.	Qty. Req'd.	Part No.	Description
1	4	2406-0007	Drain Plug (Cast series)
1	4	2406-0016	Drain Plug (316 Stainless series)
2	1	0150-9000C	Pump Casing (Cast series)
2	1	0150-9000S	Pump Casing (Stainless series)
2A	1	0152-9000C	Pump Casing (Reverse)(Cast series)
2A	1	0152-9000S	Pump Casing (Reverse)(Stainless)
3	1	2253-0002	Impeller Nut (Cast series)
3	1	2253-0006	Impeller Nut (Stainless series)
4	1	0401-9100P	Impeller (Model 9203C) (Nylon)
4	1	0402-9100P	Impeller (Model 9203S) (Poly)
4A	1	0404-9100P	Impeller (Reverse)(Cast series)
4A	1	0403-9100P	Impeller (Reverse)(Stainless series)
5	1	1610-0015	Key (Cast series)
5	1	1610-0044	Key (Stainless series)
6	1	1700-0100	Gasket (Cast series)
7	1	1720-0083	O-Ring
8	1	2120-0008	Mechanical Seal (Optional Buna-N)
8	1	2120-0009	Mechanical Seal (Cast series)

Ref. No.	Qty. Req'd.	Part No.	Description
8	1	3430-0589	Mech. Seal (Silicon Carbide) (Stainless) Includes ref #5 O-Ring
9	1	0750-9200C3	Mounting Flange (Cast series)
9	1	0756-9200S	Mounting Flange (Stainless series)
10	4	2210-0020	Bolt (Cast series)
10	4	2210-0125	Bolt (Stainless series)
11	1	1410-0056	Slinger Ring
12	2	2000-0010	Ball Bearing
13	1	0505-9200	Pump Shaft
14	1	1610-0004	Key
15	1	1820-0013	Bearing Retainer
16	1	2210-0003	Bolt
17	1	2270-0092	Retaining Washer
18	1	1410-0107	Spacer
19	4	N/A	Bolt (part of clutch assy)
20	1	2526-0012	Clutch
21	3	2230-0001	Set Screw
22	1	3430-0592	Clutch Kit
23	1	2300-0025	Protective Cover
24	1	0753-9200C	Mounting Bracket

NOTE

SOME PARTS ARE NON-STOCK
ITEMS AND MAY NEED TO BE
ORDERED

NOTE

PLEASE ADD PREFIX **H** TO
PART NUMBER TO REFLECT
CROPLANDS PART NUMBER

ALL 9203 SERIES		GPM at HP		GPM at HP		GPM at HP		GPM at HP		GPM at HP		GPM at HP		GPM at HP			
	RPM	10 PSI		20 PSI		40 PSI		60 PSI		80 PSI		100 PSI		120 PSI		140 PSI	
	2400	80	1.9	65	1.8	26	1.3										
3600	105	5.3	105	5.3	92	5.0	50	3.7									
4200	122	8.2	120	7.9	115	7.7	98	7.1	56	5.3							
5000	140	12.6	140	12.6	138	12.6	130	12.2	118	11.6	88	9.9	45	7.2			
5500	140	14.9	140	14.9	138	14.9	135	15.2	130	15.2	118	14.4	90	12.5	60	9.8	
6000	140	17.1	140	17.1	140	17.5	140	18.0	135	18.2	130	18	125	18.2	100	16.3	

ALL 9203 SERIES		LPM at HP		LPM at HP		LPM at HP		LPM at HP		LPM at HP		LPM at HP		LPM at HP			
	RPM	0.7 BAR		1.4 BAR		2.8 BAR		4.1 BAR		5.5 BAR		6.9 BAR		8.3 BAR		9.7 BAR	
	2400	303	1.9	246	1.8	98	1.3										
3600	397	5.3	397	5.3	348	5.0	189	3.7									
4200	462	8.2	454	7.9	435	7.7	371	7.1	212	5.3							
5000	530	12.6	530	12.6	522	12.6	492	12.2	447	11.6	333	9.9	170	7.2			
5500	530	14.9	530	14.9	522	14.9	511	15.2	492	15.2	447	14.4	341	12.5	227	9.8	
6000	530	17.1	530	17.1	530	17.5	530	18.0	511	18.2	492	18	473	18.2	379	16.3	

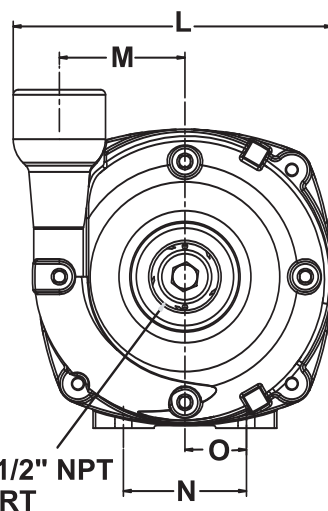
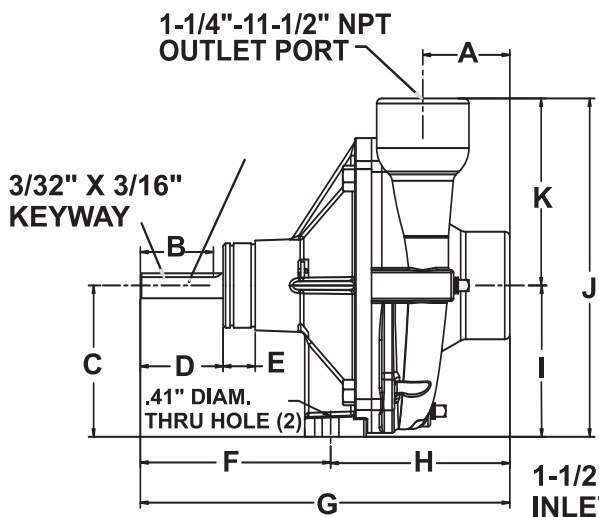

9203C

Dimensions		
	Inches	mm
A	2.13	54
B	1.78	45.2
C	3.69	93.7
D	2.02	51.3
E	0.78	19.9
F	4.64	117.8
G	9.01	228.9
H	4.37	111.1
I	3.69	93.7
J	8.25	209.6
K	4.56	115.9
L	7.78	197.7
M	3.06	77.8
N	3	76.2
O	1.5	38.1

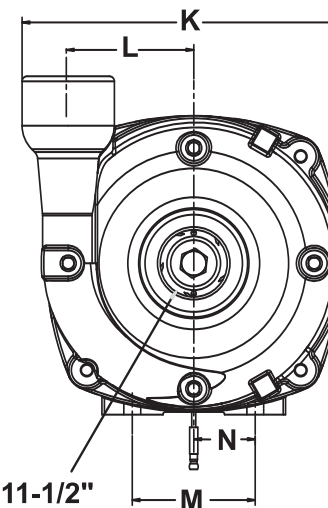
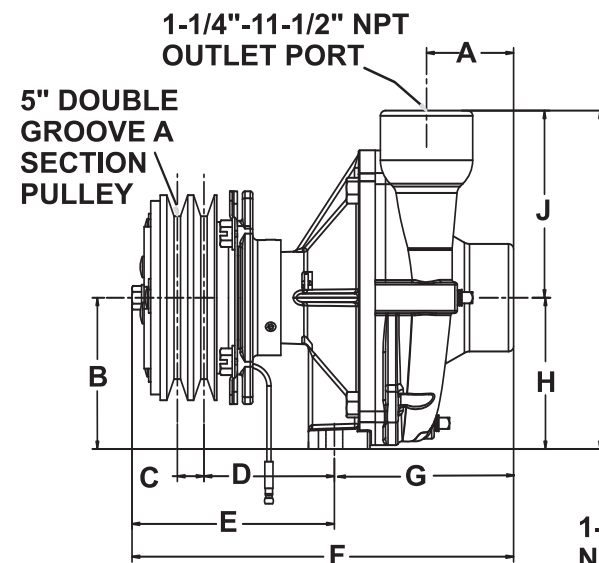

9263

Dimensions		
	Inches	mm
A	2.12	53.8
B	3.69	93.7
C	0.65	16.5
D	3.18	80.7
E	4.93	125.3
F	9.31	236.4
G	4.32	109.7
H	3.69	93.7
I	8.25	209.6
J	4.56	115.9
K	7.78	197.7
L	3.11	78.9
M	3	76.2
N	1.5	38.1

Pedestal Mount, Cast Iron & Stainless Steel

Series 9203C and 9203S Includes Models: 9203C, 9203S, 9203C-R and 9203S-R



Models 9203C and 9203S

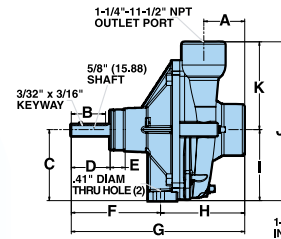

Standard Rotation

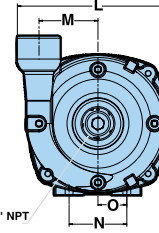

Dimensions		
	Standard	mm
A	2.13	54.0
B	1.78	45.2
C	3.69	93.7
D	2.02	51.3
E	0.78	19.9
F	4.64	117.8
G	9.01	228.9
H	4.37	111.1
I	3.69	93.7
J	8.25	209.6
K	4.56	115.9
L	7.78	197.7
M	3.06	77.8
N	3.00	76.2
O	1.50	38.1

FEATURES

- Available in cast iron and 316 stainless steel
- Pedestal mount, direct drive
- Port sizes: 1/2" NPT inlet, 1/4" NPT outlet
- Max. fluid temperature: 140°F/60°C
- Impeller: Nylon (cast iron standard); polypropylene (stainless standard)
- Pump shaft rotation: CCW* (9203C-R is CW)
- Weight: 19 lbs./8.6 kg
- Pump seals: Cast Iron models – Viton/ceramic standard; Life Guard® silicon carbide (B) and Buna-N ceramic available; Stainless Steel models – Life Guard® silicon carbide (B) standard
- 220 x 200 Universal flange available

Models 9203C-R and 9203S-R

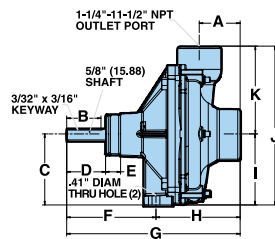

Reverse Rotation

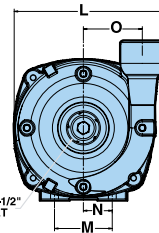

Dimensions		
	Standard	mm
A	2.13	54.0
B	1.78	45.2
C	3.69	93.7
D	2.02	51.3
E	0.78	19.9
F	4.64	117.8
G	9.01	228.9
H	4.37	111.1
I	3.69	93.7
J	8.25	209.6
K	4.56	115.9
L	7.78	197.7
M	1.50	38.1
N	3.06	77.8
O	3.00	76.2

Order Information

Model Number	Max GPM	Max PSI	Max RPM	Shaft Output
9203C†	140	170	6000	5/8" solid shaft
9203C-R (CW)	140	170	6000	5/8" solid shaft
9203S	140	170	6000	5/8" stainless steel shaft
9203S-R (CW)	140	170	6000	5/8" stainless steel shaft
3430-0332	Seal and o-ring repair kit			
3430-0589	Life Guard® silicon carbide seal kit			

† Universal Flange (220 x 200) - Add Suffix "U" (i.e.: 9203C-U)
Life Guard® silicon carbide seal - Add suffix "B" (i.e.: 9203C-B)

9203C/-U		
Add the following to standard dimensions		
	Standard	mm
A	0.78	19.81
H	0.78	19.81
G	0.78	19.81
K	0.06	1.52

9203C, 9203S, 9203C-R, 9203S-R

English Standard

RPM	10 PSI		20 PSI		40 PSI		60 PSI		80 PSI		100 PSI		120 PSI		140 PSI	
	GPM	HP	GPM	HP	GPM	HP	GPM	HP	GPM	HP	GPM	HP	GPM	HP	GPM	HP
2400	80	1.9	65	1.8												
3600	105	5.3	105	5.3	92	5.0	50	3.7								
4200	122	8.2	120	7.9	115	7.7	98	7.1	56	5.3						
5000	140	12.6	140	12.6	138	12.6	130	12.2	118	11.6	88	9.9	45	7.2		
5500	140	14.9	140	14.9	138	14.9	135	15.2	130	15.2	118	14.4	90	12.5	60	9.8
6000	140	17.1	140	17.1	140	17.5	140	18.0	135	18.2	132	18	125	18.2	103	16.3

9203C, 9203S, 9203C-R, 9203S-R

Metric

RPM	0.7 BAR		1.4 BAR		2.8 BAR		4.1 BAR		5.5 BAR		6.9 BAR		8.3 BAR		9.7 BAR	
	LPM	HP	LPM	HP	LPM	HP	LPM	HP	LPM	HP	LPM	HP	LPM	HP	LPM	HP
2400	303	1.9	246	1.8												
3600	397	5.3	397	5.3	348	5.0	189	3.7								
4200	462	8.2	454	7.9	435	7.7	371	7.1	212	5.3						
5000	530	12.6	530	12.6	522	12.6	492	12.2	447	11.6	333	9.9	170	7.2		
5500	530	14.9	530	14.9	522	14.9	511	15.2	492	15.2	447	14.4	341	12.5	227	9.8
6000	530	17.1	530	17.1	530	17.5	530	18.0	511	18.2	500	18	473	18.2	409	16.3

*CCW (counterclockwise) CW (clockwise) are determined when looking at the shaft end.