

CROPLANDS PART NUMBERS: H9303P-HM1C – HYDRAULIC CENTRIFUGAL PUMP POLY



**SERIES 9303P
Polypropylene
Centrifugal Pumps**

Max. Flow Rate:113 gpm
Max. Pressure:125 psi
Ports:1-1/2" NPT Inlet
1-1/4" NPT Outlet
Hydraulic Ports:1/2" NPT Inlet
1/2" NPT Tank

9303

9303P-HM1C

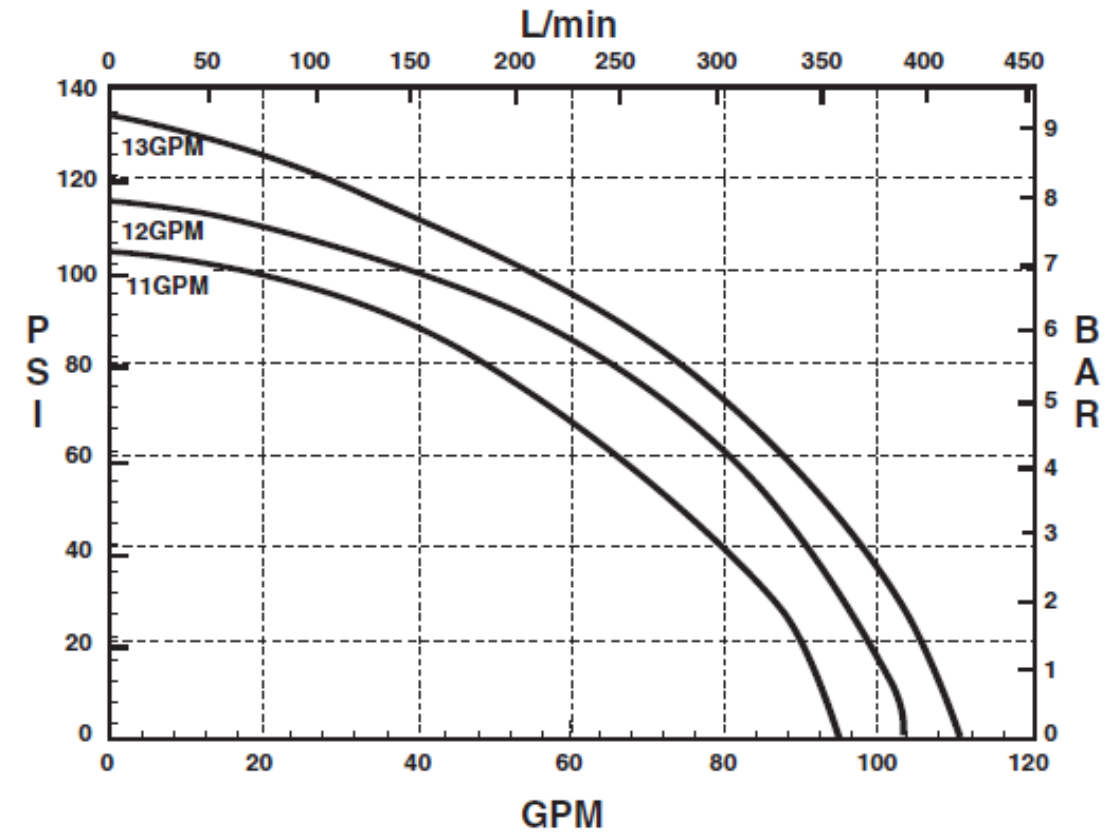

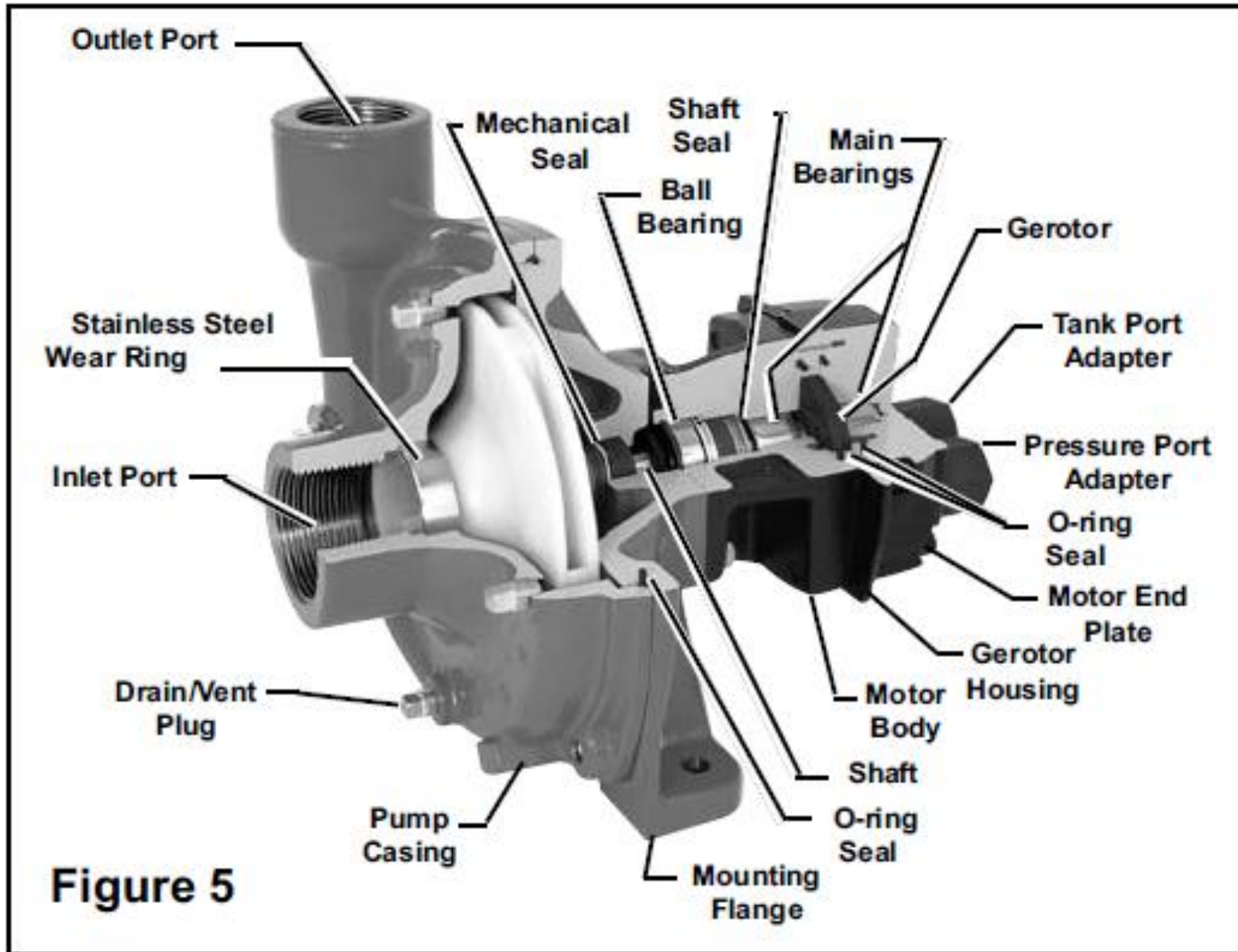

All 9300 Polypropylene Series Pumps

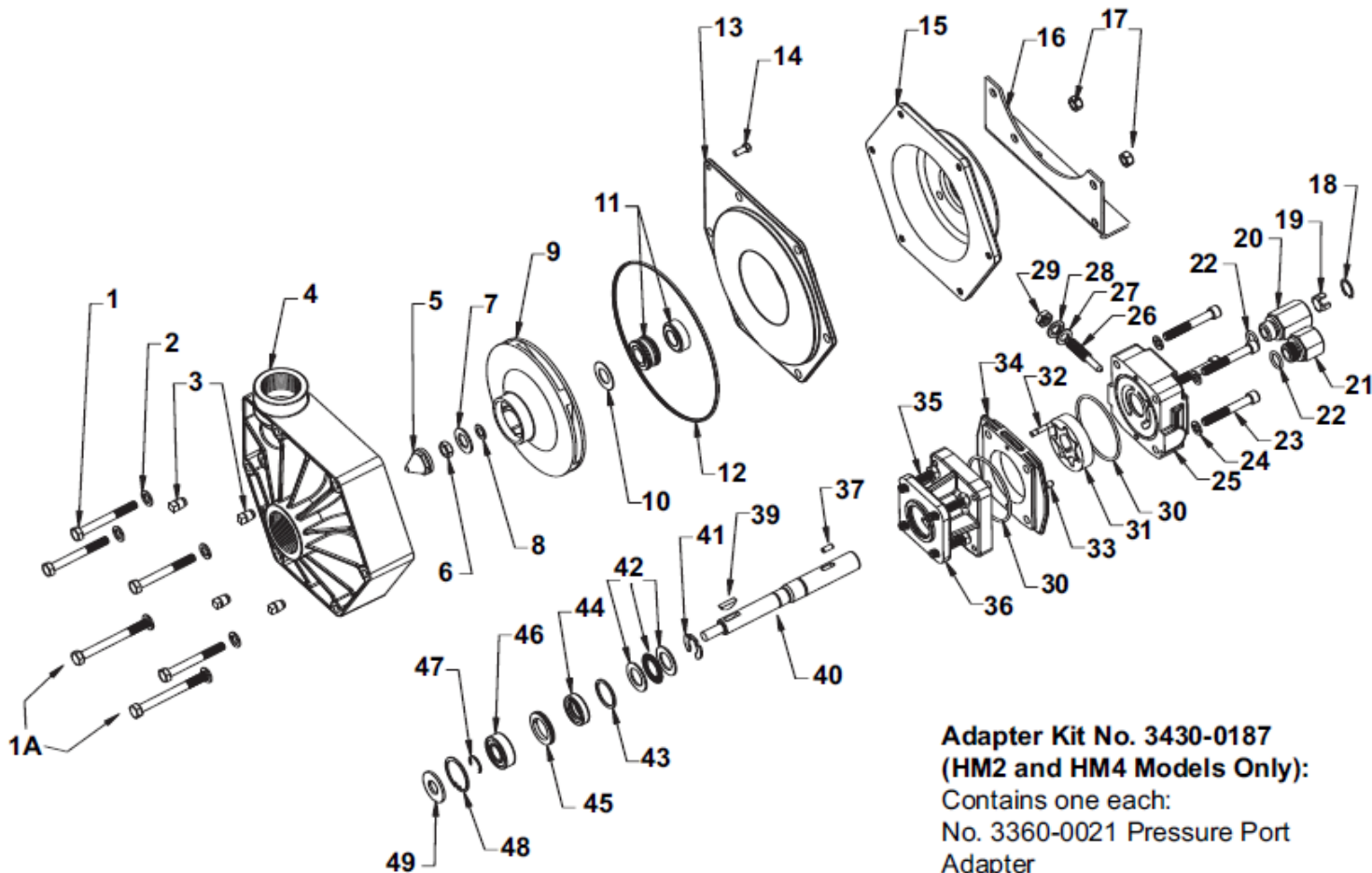

Repair Parts Kit No. 3430-0445

Contains: One o-ring (Ref. 12), one rubber gasket (Ref. 10), one mechanical seal (Ref. 11), one gasket (Ref. 7) and one washer (Ref. 8).

Silicon Seal Parts Kit # 3430-0593

Contains one each: mechanical seal (Ref. 11) and o-ring (Ref. 12).

Adapter Kit No. 3430-0187 (HM2 and HM4 Models Only):

Contains one each:
 No. 3360-0021 Pressure Port Adapter
 No. 3373-0020 (Size #1)
 No. 3373-0021 (Size #2)
 No. 3373-0022 (Size #3).
 No. 1720-0108 Adapter O-ring and
 No. 1720-0105 Orifice O-ring (Qty. 3).

NOTE
 SOME PARTS ARE NON-STOCK
 ITEMS AND MAY NEED TO BE
 ORDERED

NOTE: When ordering parts, give QUANTITY, PART NUMBER, DESCRIPTION, and COMPLETE MODEL NUMBER. Reference numbers are used ONLY to identify parts in the drawing and are NOT to be used as order numbers.

Parts Kit No. 3430-0178

Contains: One each ball bearing (Ref. 46), motor shaft seal (Ref. 44), thread seal gasket (Ref. 27), and washer (Ref. 28); two each motor housing o-rings (Ref. 30), and port adapter o-rings (Ref. 22).

Hydraulic Motor Part Nos.

2500-0019C (HM1C Models)
 2500-0022C (HM2C Models)
 2500-0013C (HM3C Models)
 2500-0014C (HM4C Models)
 2500-0021C (HM5C Models)

Ref. No.	Qty. Req'd.	Part No.	Description
1	4	2210-0087	Hex Head Cap Screw
1A	2	2210-0016	Hex Head Cap Screw (Base Only)
2	6	2270-0041	Washer
3	4	2406-0020	Pipe Plug
4	1	0700-9000P	Pump Casing
5	1	2250-0052	Impeller Nut
6	1	2250-0051	Jam Nut
7	1	1700-0097	Gasket (Viton)
8	1	2270-0057	Washer
9	1	0402-9100P	Impeller
10	1	1700-0100	Rubber Gasket
11	1	2120-0009	Mechanical Seal (Viton/Ceramic) (Std)
11	1	3430-0593	Mechanical Seal (Silicon Carbide)(Optional)
12	1	1721-0083	O-Ring
13	1	0750-9300P	Cover
14	1	2210-0088	Screw
15	1	0750-9006C	Intermediate Flange
16	1	1510-0063	Base Plate
17	2	2250-0008	Hex Nut
18	1	1820-0038	Retaining Ring
19	1	3260-0068	Poppet
20	1	3320-0049	Check Valve Body
21	1	3360-0021	Pressure Port Adapter
22	2	1720-0108	O-ring
23	4	2220-0045	Socket Head Cap Screw (HM2, HM4C Model)
23	4	2220-0044	Socket Head Cap Screw (HM3C Model)
23	4	2220-0021	Socket Head Cap Screw (HM1C Model)
23	4	2220-0032	Socket Head Cap Screw (HM5C)
24	4	2270-0039	Washer
25	1	0251-2500C2	Motor End Plate: Includes (1) Main Bearing
26	1	3220-0029	Valve Stem
27	1	1700-0047	Gasket
28	1	2270-0027	Washer
29	1	2250-0038	Lock Nut
30	2	1720-0110	O-Ring
31	1	3900-0022	Gerotor (HM1C Models)

Ref. No.	Qty. Req'd.	Part No.	Description
31	1	3900-0023	Gerotor (HM2C Models)
31	1	3900-0024	Gerotor (HM3C Models)
31	1	3900-0025	Gerotor (HM4C Models)
31	1	3900-0048	Gerotor (HM5C Models)
32	1	1600-0042	Dowel Pin (HM2C & HM4C Models)
32	1	1600-0037	Dowel Pin (HM1C & HM5C Models)
32	1	1600-0068	Dowel Pin (HM3C Models)
33	1	1600-0045	Dowel Pin (HM2C & HM4C Models)
33	1	1600-0044	Dowel Pin (HM1C & HM5C Models)
33	1	1600-0052	Dowel Pin (HM3C Models)
34	1	0701-2500C1	Gerotor Housing (HM2C Models) 1/4" Wide
34	1	0700-2500C1	Gerotor Housing (HM1C Models) 1/2" Wide
34	1	0703-2500C1	Gerotor Housing (HM4C Models) 5/16" Wide
34	1	0702-2500C1	Gerotor Housing (HM3C Models) 1" Wide
34	1	0704-2500C1	Gerotor Housing (HM5C Models) 5/8" Wide
35	4	2210-0021	Hex Head Cap Screw
36	1	0151-2500C	Motor Body: Includes (1) Main Bearing
37	1	1610-0032	Roll Pin (HM2C & HM4C Models)
37	1	1610-0031	Roll Pin (HM1C & HM5C Models)
37	1	1610-0055	Roll Pin (HM3C)
39	1	1610-0012	Woodruff Key
40	1	0507-2500	Shaft (HM2C & HM4C Models) 7-1/16" Long
40	1	0506-2501	Shaft (HM1C & HM5C Models) 7-21/64" Long
40	1	0514-2500	Shaft (HM3C Models) 7-13/16" Long
41	1	1810-0026	Snap Ring
42	1	2029-0014	Thrust Bearing Assembly - Consists of: (1) Thrust Bearing & (2) Thrust Bearing Races
43	1	1410-0074	Seal Spacer
44	1	2104-0005	Shaft Seal
45	1	1410-0073	Spacer
46	1	2000-0010	Ball Bearing
47	1	1810-0014	Snap Ring
48	1	1820-0013	Retaining Ring
49	1	1410-0056	Slinger Ring

NOTE

**PLEASE ADD PREFIX H TO
PART NUMBER TO REFLECT
CROPLANDS PART NUMBER**