

ITEM NO.	PART NUMBER	DESCRIPTION	QTY.
1	A300130	FILTER BASKET LARGE 254MM DEEP	1
2	A3510040	LID/RING KIT 355MM	1
3	A3510060	LID/RING KIT 455MM	1
4	A354010	LID 6" C/W SPRING BREATHER & OUTLET	1
5	A354030	LID 4" C/W BREATHER & SEAL	1
6	BP-180	MUDFLAP PLATE	2
7	BP-184A	JOCKEY STAND SHORT PINTO	1
8	BP-400D	SUSPENSION SIMPLICITY DROP AXLE	1
9	BP-542	MUDFLAP WHITE	2
10	BP-700-9AA	PIN 30MM X 155MM HAYLITE	4
11	HP2000ABA	CHASSIS AIRBLAST 2000LT HAYLITE	1
12	HP-006	SPIGOT PLATE JACK STAND	1
13	HP-014	HYDRAULIC CYLINDER 2 X 24	2
14	HP-016	HYDRAULIC CYLINDER 2.0 X 10	2
15	HP-024	SELF STEERING DRAWBAR 2PTL	1
16	HP-024-7	CABLE HOLDER BRACKET	1
17	HP-202	TYRE & WHEEL 10R X 15 LANDCRUISER	4
18	HP-219-31A	QM SARDI FAN RP 9.8 MOTOR w/ FLANGE	8
19	HP-229	MANIFOLD BRACKET HP-223C2	1
20	HP-274A-1	SUB FRAME QM 2000LT	1
21	HP-274A-2F	BOOM ARM LH VER4 2000LT	1
22	HP-274A-3F	BOOM ARM RH QM VER4 2000LT	1
23	HP-274A-4E	FRONT BRACE QM 2000LT	1
24	HP-274A-5	PARKING ARM	2
25	HP-274A-5-1	PARKING BRACKET QM	1
26	HP-274A-6F	TOP BRACE QM 2000LT	1
27	HP-274A-10	DROPPER ARM OUTER	2
28	HP-274A-10-3	QM DROPPER TUBE BUMPER	2
29	HP-274A-11	STEEL BUSH QM	2
30	HP-274A-14	CLAMP HALF SADDLE 90MM	6
31	HP-274A-15A	MAIN TOWER ASSEMBLY QM	1
32	HP-274A-16A	NYLON BUTTON 50 X 10	8
33	HP-274B-12B	SWIVEL BRACKET V3 FOR ORORA	2
34	HP-274B-18	BRACKET CYLINDER ORORA	2
35	HP-275C	CLAMP CAST QUICK ADJUST	8
36	HP-275C-1	CLAMP PLATE QM500	8
37	HP-286A	BRACKET ECM 3000LT QUANTUM	2
38	HP-288	BRACKET MUDFLAP BP-400D	2
39	HP-289	MANIFOLD BRACKET A463CCRO08A	1
40	HP-298-15A	OIL COOLER 12V AIR TYPE HYDAC	1
41	HP-298-15A-1	BRACKET OIL COOLER	1
42	HP-298-15A-2	TOP SUPPORT BRACKET OIL COOLER	1
43	HP-402A	RETRACTABLE STEP 2000LT	1
44	HP-404L	SIDE RAIL LH 2000LT	1
45	HP-404R	SIDE RAIL RH 2000LT	1
46	HP-405	BRACKET FILTER SUCTION	1
47	HP-411	FRONT TANK SUPPORT 2000LT	1
48	HP-413	CROSS BAR	1
49	HP-414	FRONT TIE DOWN ROD 2000LT	2
50	HP-415L	REAR LEFT TIE DOWN ROD 2000LT	1
51	HP-415R	REAR RIGHT TIE DOWN ROD 2000LT	1
52	HP-820	BRACKET QM HOOK TYPE 600 X 800	2
53	HP-829	BRACKET HOOK TYPE 600MM X 1000MM	2
54	P2000AAB-RAW	TANK 2000LT POLY RAW AIRBLAST	1
55	XBMBB65	U-BOLT 65MM X 12	4
56	XBMBB50	U-BOLT 50MM X 10	2
57	S0SQWASHER	50MM SQUARE WASHER	4
58	M20X140BOLT	M20 X 140 HEX HEAD BOLT HT ZP	1
59	M20X60	M20 X 60 SET SCREW HT ZP	2
60	M20FWASHER	M20 FLAT WASHER ZP	2
61	M20HNUT	M20 HALF NUT ZP	2
62	M20NNUT	M20 NYLOC NUT HT ZP	1
63	M16X100BOLT	M16 X 100 BOLT HT ZP	2
64	M16X50	M16 X 50 HEX HEAD SET SCREW HT ZP	8
65	M16X45SS	M16 X 45 S/S HEX HEAD SET SCREW	8
66	M16X40SS	M16 X 40 S/S HEX HEAD SET SCREW	8
67	M16X35SS	M16 X 35 S/S HEX HEAD SET SCREW	8
68	M16FWASHER	M16 FLAT WASHER ZP	20
69	M16NNUT	M16 NYLOC NUT HT ZP	10
70	M16SSHNUT	M16 S/S HEX NUT	8
71	M16SSSWASHER	M16 S/S SPRING WASHER	16
72	M12X100BOLT	M12 X 100 HEX HEAD BOLT HT ZP	2
73	M12X40	M12 X 40 HEX HEAD SET SCREW HT ZP	4
74	M12X40SS	M12 X 40 SET SCREW S/S HT ZP	12
75	M12X35	M12 X 35 SET SCREW HT ZP	32
76	M12X30	M12 X 30 SET SCREW HT ZP	18
77	M12FWASHER	M12 FLAT WASHER ZP	104
78	M12HNUT	M12 HEX NUT HT ZP	8
79	M12NNUT	M12 NYLOC NUT HT ZP	60
80	M12SSNNUT	M12 S/S NYLOC NUT	12
81	M12SSFWASHER	M12 S/S FLAT WASHER	24
82	M10X30	M10 X 30 SET SCREW HT ZP	4
83	M10X25	M10 X 25 SET SCREW HT ZP	8
84	M10X20	M10 X 20 SET SCREW HT ZP	2
85	M10FWASHER	M10 FLAT WASHER ZP	30
86	M10NNUT	M10 NYLOC NUT HT ZP	16
87	M10SSWASHER	M10 SPRING WASHER ZP	2
88	MBX35	M8 X 35 SET SCREW HT ZP	8
89	MBX30	M8 X 30 SET SCREW HT ZP	5
90	M8FWASHER	M8 FLAT WASHER ZP	26
91	M8NNUT	M8 NYLOC NUT HT ZP	13
92	M6X20CSSCREW	M6X20 C/S HEAD SCREW	6
93	M6X16	M6 X 16 SET SCREW HT ZP	6
94	M6FWASHER	M6 FLAT WASHER ZP	18
95	M6NNUT	M6 NYLOC NUT HT ZP	12
96	M6GNIPPLE	M6 GREASE NIPPLE	4

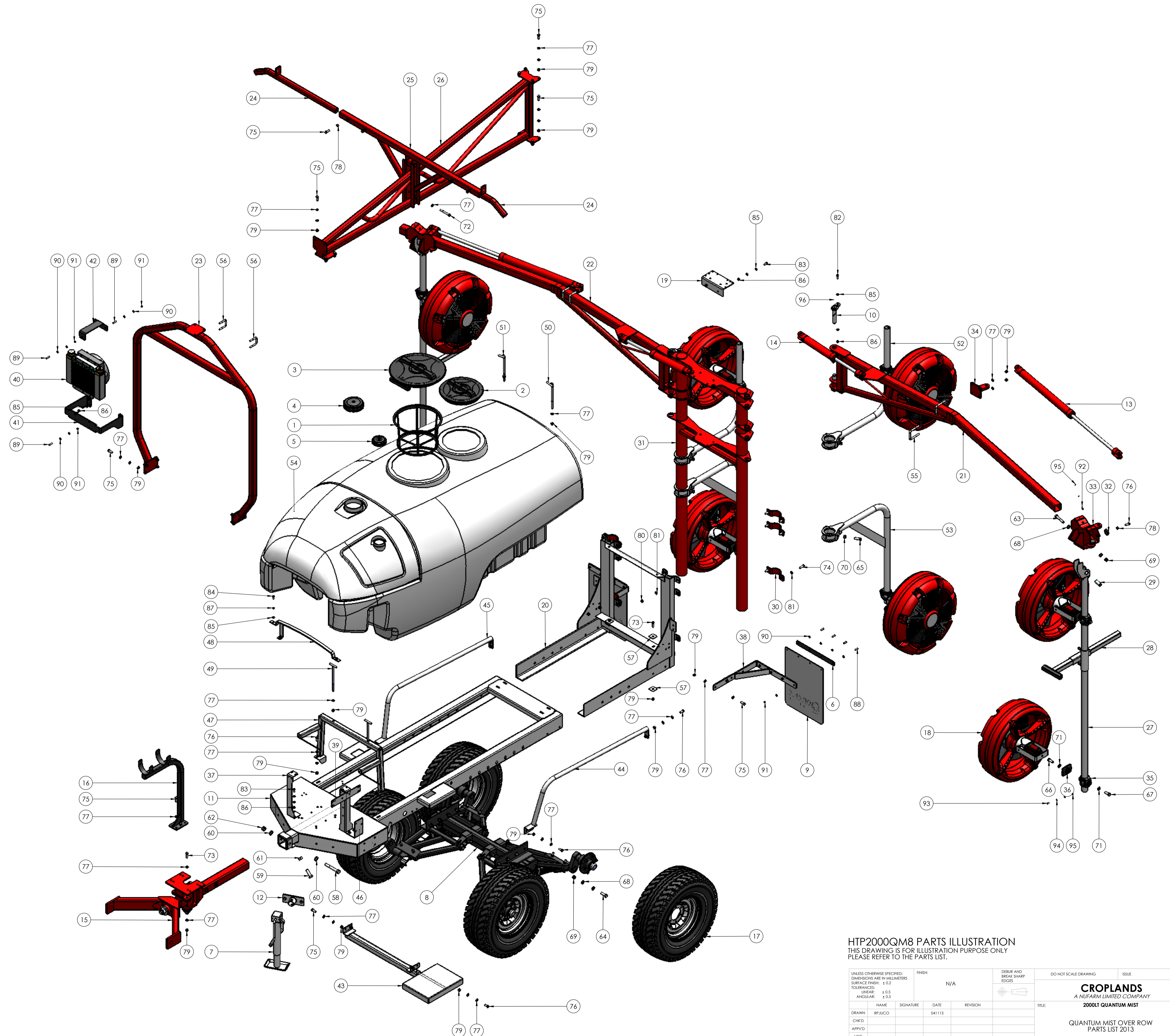

**HTP2000QM8 PARTS ILLUSTRATION**  
 THIS DRAWING IS FOR ILLUSTRATION PURPOSE ONLY  
 PLEASE REFER TO THE PARTS LIST.

UNLESS OTHERWISE SPECIFIED: DIMENSIONS ARE IN MILLIMETERS SURFACE FINISH: ± 0.2 TOLERANCES: LINEAR: ± 0.3 ANGULAR: ± 0.5	FINISH: N/A	REPAIR AND BREAK SHARP EDGES	DO NOT SCALE DRAWING	ISSUE
DRAWN: RP/JUCO		SIGNATURE:	DATE: 04/11/13	REVISION:
CHK'D:				
APP'VD:				
MFG:				
Q.A.		MATERIAL: N/A	DWG NO. HTP2000QM8	A1
COPYRIGHT PROPRIETOR: ALL RIGHTS RESERVED BY NUFARM LIMITED COMPANY PTY. LTD. REPRODUCTION OF THIS DOCUMENT IS PROHIBITED WITHOUT THE CONSENT OR AUTHORITY OF CROPLANDS PTY. LTD.		WEIGHT:	SCALE: 1:17.5	SHEET 1 OF 1

**CROPLANDS**  
 A NUFARM LIMITED COMPANY  
 2000LT QUANTUM MIST  
 QUANTUM MIST OVER ROW  
 PARTS LIST 2013