

CROPLANDS

OPERATORS MANUAL TRAYPAK SPRAYERS

MANUAL REEL MODELS:

US20F/252/HR30 | US30F/30/HR30TG | US60F/30/HR30TG | US60F/40/TWIN

US500/30/HR30TG | US500/70/HR30TG | US500/40/TWIN

WWW.CROPLANDS.COM.AU

STOP

BEFORE COMMENCING
operation, **ENSURE** you read
& understand this manual, its
contents, and any additional
information supplied.



GP-OMTRAY-B



CROPLANDS IS CONTRIBUTING TO A SUSTAINABLE FUTURE

INTRODUCTION

GENERAL MANAGER'S WELCOME



Sean Mulvaney
General Manager

Dear Customer

Congratulations on the purchase of your new sprayer and thank you for supporting another true blue Australasian manufacturer. For over 50 years Croplands have been delivering spraying solutions and ongoing support for a variety of applications whilst investing in long term partnerships with our suppliers, distributors, end users and local communities. These partnerships are absolutely key in our commitment to support our products into the future.

At Croplands, we are committed to sourcing the very best technology from around the globe and adapting these products to our specific requirements. When these products don't yet exist, we innovate through continuous investment in our own research and development.

Croplands is a wholly owned subsidiary of Nufarm Ltd, the largest supplier of crop protection products in Australasia. This brings a unique understanding and collaborative approach to new market developments, challenges and opportunities.

Please take the time to thoroughly read this manual before you operate your sprayer. This will provide direction to ensure safe usage and help optimise the performance of your investment. Your feedback is welcome and valued.

We trust you will be happy with your sprayer and the level of support - our goal is to be your preferred spraying solutions partner from this point onwards.

Yours Sincerely

Sean Mulvaney
General Manager

Croplands has taken steps to ensure this operator's manual is as current and as accurate as possible. Due to the ever-changing markets of cropping and farming, Croplands is constantly striving to be at the forefront of innovation and technology. While the information in this manual is considered accurate at the time of writing, Croplands reserves the right to change this information without notice. Croplands will not accept liability for any inaccuracy in this publication, or changes forthwith.



CONTENTS

SECTION 1 **IMPORTANT INFORMATION**

About this manual	4
Terminology	4
Before operating your sprayer	4
Intended use	4
Warranty	5

SECTION 2 **SAFETY**

Safety signs and decals	6
-------------------------	---

SECTION 3 **PRODUCT IDENTIFICATION, & SPECIFICATION**

Croplands TrayPak Sprayer	7
Specifications	7
Tanks	7
Honda Power	7
Pumps	8
Controls	8
Hose Reels & Spray Guns	9
Manuals	9
US20F, 30F & 60F models	10
US500 models	12

SECTION 4 **PRE-OPERATION, MOTORISED MODELS**

Electric Reels - Retraspray	14
Unloading	14
Fitment	14
Hook-Up	14
Description of the plumbing	14
Spray gun	16
Spray guns & accessories	17
Filling, filters & draining	17
Pre-operation check-list	18
Initial start-up procedure, motorised sprayer	18
Shut down	20

SECTION 5 **OPERATION**

Safety	22
Daily start-up procedure	22
Adding chemical to the spray tank	22
Operating the spray gun	23
Hand gun spraying method	24
Operating pointers	24
Boom spraying	24
Emergency Action Plan	24
Clean & flush the sprayer	25
Using tank & equipment cleaners	25

SECTION 6 **SPRAYING INFORMATION & CALIBRATION**

When to spray	26
Useful formula	26
Calibration - general	26
Spot sprayer calibration	26
Spray quality	27
Boom spraying	27

SECTION 7 **MAINTENANCE & TROUBLESHOOTING**

Daily maintenance	28
20 hours maintenance	28
Annual maintenance	28
Troubleshooting pump problems	29

SECTION 8 **ASSEMBLY DRAWINGS** **30**

200F/300F BASE ASSEMBLY	31
US20F/252/HR30	32
US30F/30/HR30TG	33
600F BASE ASSEMBLY	34
US60F/40/TWIN	35
US500/70/HR30TG	36

SECTION 9 **INDEX** **37**

SECTION 1

IMPORTANT INFORMATION

ABOUT THIS MANUAL

This manual provides assembly, setting up, operating and maintenance instructions for the TrayPak sprayer as listed on the front cover.

The specifications of each sprayer is detailed in Section 3 (Product identification & specifications) of this manual. Some model types may also have different options available.

Some features explained in this manual may not be installed on your sprayer.

Please pass on this manual with the sprayer at the time of resale for usage by the new owner.

This manual, GP-OMTRAY-B, was first published in August 2022 with an FSC update August 2024.

Check online as there may be more recent revisions of this manual. www.croplands.com.au

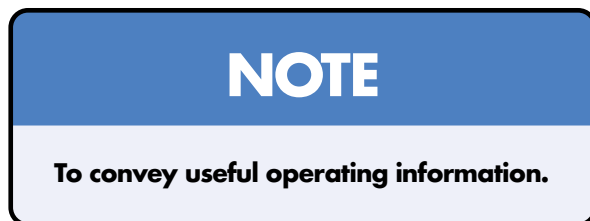

TERMINOLOGY

These terms/symbols used throughout this manual:

NOTE	This Note sign is in place to convey useful information and will help you to identify the best possible way to operate the machine.
CAUTION	This Caution sign shows the potential for incident. An incident may include damage to the machine itself, or possible injury to the operator.
WARNING	This warning sign shows the potential for risk or injury and highlights the need for steps to be taken to protect ones safety.
DANGER	This Danger sign will be used in areas where the highest risk is present. Always read the information on these signs and ensure you are taking steps to prevent risk or injury.



BEFORE OPERATING YOUR SPRAYER

Before attempting to use your sprayer, make sure you read all Operator Manuals for this sprayer including but not limited to:

This Operator's Manual, and all other supplied manuals for items such as Pump etc.

And properly understand:

- All Safety Issues.
- Assembly & Installation instructions.
- Calibration of the sprayer.
- Sprayer Operation.
- Sprayer Maintenance.



INTENDED USE

Croplands sprayers are designed to be used for multipurpose spraying of herbicides, pesticides and fertilisers. The sprayer must not be used for any other purpose.

SECTION 1

IMPORTANT INFORMATION

WARRANTY POLICY

Each sprayer will be delivered with a Warranty & Pre-Delivery Booklet which includes:

- the sprayer's unique serial number,
- the Sprayer's specification sheet,
- a pre-delivery checklist and
- outlines the Croplands Warranty policy.

We ask that our customers complete these forms in the presence of a Dealer and/or Croplands representative as a part of the sprayer's delivery process.

Always contact your Croplands Dealer first and foremost for warranty matters.

NOTE

For full conditions of warranty & warranty policy, please see the Warranty & Pre-Delivery booklet provided with this sprayer.

CROPLANDS

**WARRANTY & PRE-DELIVERY
COMPACT
SPRAYERS**

WWW.CROPLANDS.COM.AU

STOP
BEFORE COMMENCING
operation, **ENSURE** you read
& understand this manual, its
contents, and any additional
information supplied.

GP-WARO-A | 2025 update

 **CROPLANDS IS CONTRIBUTING TO A SUSTAINABLE FUTURE**

SECTION 2

SAFETY

The supplied (as a separate document along with this sprayer) Croplands SAFETY manual must be read and understood before operating your TrayPak Sprayer.



SAFETY SIGNS AND DECALS

All signs and decals for sprayer safety and operation must be maintained in good order and replaced if damaged or missing. Most Croplands labels have a part number printed on the decal to aid identification and replacement.

Some examples are shown below.



Part No: XD - 123



Part No: XD - 125V



Part No: XD - 126V



Part No: XD - 116V



Part No: XD - 127V

SECTION 3

PRODUCT IDENTIFICATION & SPECIFICATION

CROPLANDS TRAYPAK SPRAYER

Whenever possible, use the serial number of the TrayPak sprayer when requesting service or parts information.

Where a serial plate is not provided or is no longer on the unit, use the part number from the bar code affixed to this manual or the Warranty & Pre-delivery booklet.



SPECIFICATIONS

Tanks

The Croplands TrayPak range of tanks are constructed from UV stabilised, medium density polythene for low distortion qualities and impact resistance. A screw down main lid is installed on all models and comes standard with a basket strainer. A deep sump provides excellent suction and allows the tank to completely drain.

The 200, 300 & 600 Lt models incorporate a (red) 6 litre fresh water tank for operator safety, hand washing, filter cleaning etc.



Honda Power

Croplands motorised TrayPak models use genuine Honda petrol powered motors - famous for delivering reliable, easy starting, fuel efficient performance, day in and day out.

Each motor is affixed with an identification label showing the manufacturer, model, serial number and manufacturing codes. For further information on parts etc, refer to the parts section on the Croplands website.



SECTION 3

PRODUCT IDENTIFICATION & SPECIFICATION

Pumps

Coupled to each Honda motor is an industry leading AR brand, diaphragm pump of a capacity to suit each CropPak model.

Each pump is fitted with a suitable AR manual control valve and regulator.

The pump identification label shows the name of the manufacturer, model of the pump, serial number, maximum working pressure and other requirements.



For further information on parts for your pump, refer to the parts section on the Croplands website. Use the pump model as the reference.



AR252-CRGI



AR30-CRGI

Controls

Each model uses a pressure regulating valve specific to the pump model being used, such as ..

- AR GR30 for use with AR252 pump
- AR Gi40 is used with the AR30 and AR40 pumps
- AR UCM-5 is used with the AR70-CR pump

Each regulator is fitted with an identification label.

Refer to Section 4 for detailed instruction.



AR Gi40

SECTION 3

PRODUCT IDENTIFICATION & SPECIFICATION



AR40-CRGI



AR70-CR

Hose Reels & Spray Guns

Croplands TrayPak Sprayer range is available with either single or twin 30 meter hose reel and Turbo Gun 400.



Manuals

Separate manuals for the motor/pumps are supplied along with the unit.



SECTION 3

PRODUCT IDENTIFICATION & SPECIFICATION



US20F/252/HR30



US30F/30/HR30TG



US60F/30/HR30TG



US60F/40/TWIN

SECTION 3

PRODUCT IDENTIFICATION & SPECIFICATION

MANUAL REELS

TrayPak

Croplands motorised sprayers are powered by genuine Honda motors with larger diaphragm pumps to give better spray pressure for those larger jobs.

POWERED by
HONDA™

KEY FEATURES

1. Heavy-duty hot-dip galvanised frame with carry handles
2. UV-stabilised tank with level markings
3. Large filling lid with basket strainer
4. Large sump for total emptying and easy draining and clean out
5. Genuine Honda motor to power the reliable AR diaphragm pump
6. Steel hose reel with galvanised mount, 30 metres of high-quality hose and Turbo400 gun

UNIT	WIDTH	LENGTH	HEIGHT	WEIGHT
US20F/252/HR30	1275mm	1015mm	725mm	110kg
US30F/30/HR30TG	1275mm	1015mm	725mm	115kg
US60F/30/HR30TG	1255mm	1475mm	990mm	197kg
US60F/40/TWIN	1255mm	1475mm	990mm	237kg

Disclaimer: dimensional and weight information supplied is for base model only with no options. This information is subject to change without notice.

US20F/252/HR30	200L TrayPak sprayer with galvanised frame, Honda-powered 25 L/min AR pump. Manual two-tap controls, 30m hose reel and Turbo400 gun. 6L handwash tank
US30F/30/HR30TG	300L TrayPak sprayer with galvanised frame, Honda-powered 35 L/min AR pump. Manual two-tap controls, 30m hose reel and Turbo400 gun. 6L handwash tank
US60F/30/HR30TG	600L TrayPak sprayer with galvanised frame, Honda-powered 35 L/min AR pump. Manual two-tap controls, 30m hose reel and Turbo400 gun. 6L handwash tank
US60F/40/TWIN	600L TrayPak sprayer with galvanised frame, Honda-powered 46.3 L/min AR pump. Manual two-tap controls, twin 30m hose reels and Turbo400 guns. 6L handwash tank

SECTION 3

PRODUCT IDENTIFICATION & SPECIFICATION



US500/30/HR30TG



US500/40/TWIN

UNIT	WIDTH	LENGTH	HEIGHT	WEIGHT
US500/30/HR30TG	1200mm	1700mm	1200mm	220kg

Disclaimer: dimensional and weight information supplied is for base model only with no options. This information is subject to change without notice.

US500/30/HR30TG	TrayPak 500L, AR30 pump, reel with 30m hose and Turbo400 gun, galvanised skid frame
US500/70/HR30TG	TrayPak 500L, AR70 pump, reel with 30m hose and Turbo400 gun, galvanised skid frame. AR70 pump is ideal for use with a range of booms (see page 18 and 19)
US500/40/TWIN	TrayPak 500L, AR40 pump, twin reel both with 30m hose and Turbo400 gun, galvanised skid frame

SECTION 4

PRE-OPERATION, MOTORISED MODELS

ELECTRIC REELS - RETRASPRAY	14
UNLOADING	14
FITMENT	14
HOOK-UP	14
DESCRIPTION OF THE PLUMBING	14
SPRAY GUN	16
SPRAY GUNS AND ACCESSORIES	17
FILLING, FILTERS & DRAINING	17
PRE-OPERATION CHECK-LIST	18
INITIAL START-UP PROCEDURE, MOTORISED SPRAYER	18
SHUT DOWN	20

SECTION 4

PRE-OPERATION, MOTORISED MODELS

ELECTRIC REELS - RETRASPRAY

See separate manual for the 12-volt Retraspray retractable reel and its operation.



UNLOADING

Take care when loading / unloading these sprayers. These sprayers are well past the capacity for one or two people to manually handle. Most models have either forklift or sling pickup points. Be careful of the balance.

All loading / unloading should be done with tanks empty. See Section 5 of the Safety manual.

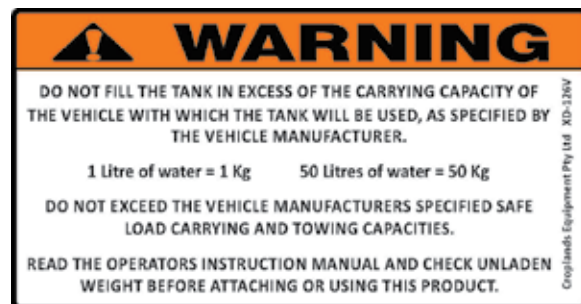

FITMENT

Make sure the unit is securely fastened. In many cases this will involve bolting the unit to a vehicle. Remember to factor in the weight of a full tank when determining the mounting, and always consult the vehicles manual for load ratings and suitable mounting points.

HOOK-UP

Connect & route a drain hose to a convenient and safe place for draining the tank.

DESCRIPTION OF THE PLUMBING

There are 3 configurations of the plumbing for the motorised pump sprayers – dependant on the choice of pump.

- The AR252 pump models are identified by the large red plastic pressure regulator.
- The AR30 & AR 40 pump models are identified by the all metal pressure regulator.
- The AR70 pump model is designed for use with a spray boom and feature a remote pressure regulator.

The operating principles for both are very similar. See below example using AR252 pump.

- A. The suction line from the tank, to the ball valve.
- B. Ball valve. To the left (as shown) is drain, to the right is to the pump. Vertically up is OFF.
- C. Suction Filter. Check and clean frequently, and especially at the commencement of any spray program (best checked before chemical is added).

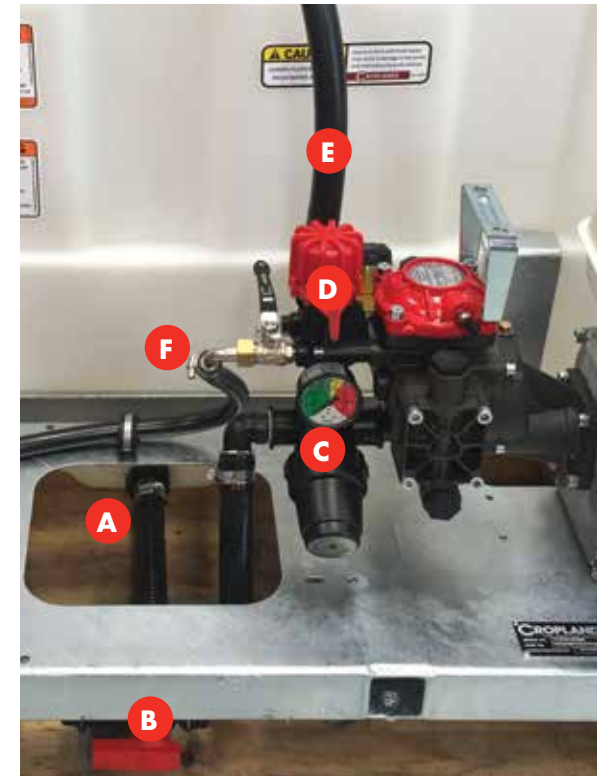

- D. Pressure Regulator – and surplus flow goes back to tank via (E) to aid agitation. The regulator also includes the pressure gauge.
- E. Return to tank. This line is also used for agitation.
- F. Spray line to the hose reel (s). Includes an on / off tap.

SECTION 4

PRE-OPERATION, MOTORISED MODELS

Note the ball valve has 3 positions, with vertical up as OFF. It's suggested the user connect a hose to the drain side of the valve and route the hose to a convenient place for safe draining of the tank.

- Be careful to dispose of any chemical in an environmentally responsible manner.



AR252 Pressure Regulator (ARGR30)

The top portion of the Pressure regulator (**red arrow**) is used to set the pressure required. Turn clockwise to increase the pressure and anti-clockwise to decrease the spray pressure. Note the AR252 pump is rated to a maximum of 25 Bar pressure.

In the example shown the non-spraying pressure has been set to 12 Bar (**green arrow**). Take note of where the maximum of 25 Bar is located on the pressure gauge (in the green sector).

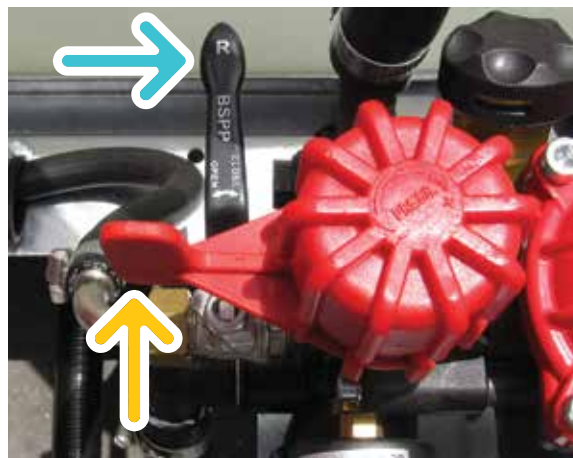
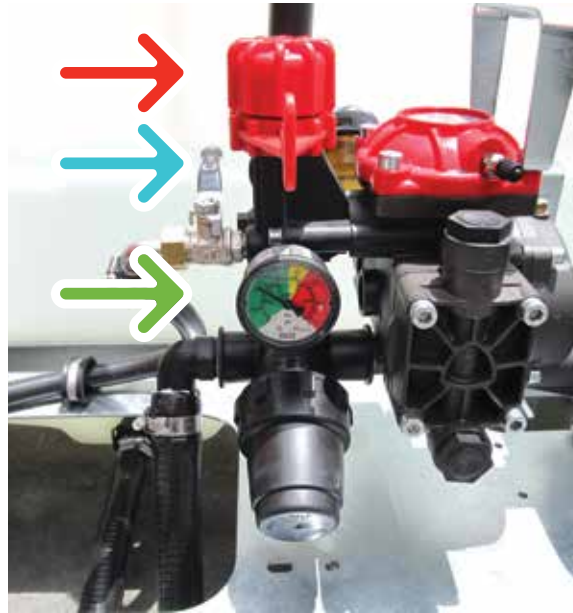

To bypass the pressure line & /or send spray / agitation back to tank, rotate the lower level of the pressure regulator to the position shown (**yellow arrow**).

Note in these 2 photo's the spray line tap is in the off position (**blue arrow**).

AR30 / 40 Pressure Regulator (ARGI40)

In the example shown the regulator has been set ready to spray (level arm is down) and the pressure has been set to 18 Bar.

The regulator has 2 places for pressure adjustment.

Course adjustment is via the wire / notches – see the (**purple arrow**).

Use positions

- 1 for up to 10 Bar,
- 2 for up to 20 Bar,
- 3 for up to 30 Bar,
- 4 for up to 40 Bar.



SECTION 4

PRE-OPERATION, MOTORISED MODELS

Fine adjustment is via the brass knob. Disengage the PRV lever (see green outline) before adjusting the brass knob as pointed, Up (increase pressure) or Down (decrease pressure).



Disengaging the lever also activates the bypass / "dump" to tank / agitation.

Note the AR30 & 40 are rated to a maximum of 40 Bar pressure which correlates to the top of the green sector of the gauge. Never operate in the yellow or red sectors.

AR70 Pressure Regulator (ARUCM-5)

The US500/70/HR30TG uses the ARUCM-5 remote 5-way controller more suited to operating a boom. In addition to the rotary (red) knob for pressure adjustment are 4 boom on /off section valves and a master "dump" to tank valve. ARUCM-4 shown.



Agitation

Note the volume of agitation from liquid bypassing the regulator (whilst spraying) is determined by the difference between pump performance (pressure) and the selected spray pressure.

SPRAY GUN

Motorised TrayPak sprayers are supplied with the Turbo 400 Spray Gun, with 1.5mm nozzle.

Practice the operation of the gun with fresh water before undertaking any chemical spraying.

Controls are a hand-held trigger, side lever for spray pattern (red arrow) and sliding / adjustable cone.

The side lever is used to adjust for cone or straight stream spray. Slide the orange cone forwards for a "fogging" type spray.



SECTION 4

PRE-OPERATION, MOTORISED MODELS

SPRAY GUNS AND ACCESSORIES

For more information on accessories etc consult the Croplands Compact sprayers & components guide.



FILLING, FILTERS & DRAINING

It's important to keep all filters clean. A careful, common sense approach to water quality, mixing of chemicals and care of filters, hoses and tank will ensure trouble free spraying.

Filling is via the lid, filtered via the basket – be very careful to not splash chemical when filling.



Draining is via the ball valve, with the tap pointing to the left (as shown). It's suggested the user connect a hose to the drain side of the valve and route the hose to a convenient safe place for draining the tank.

SECTION 4

PRE-OPERATION, MOTORISED MODELS

- Take care to dispose of chemical in an environmentally responsible manner.

Suction lines are fitted with a filter. The type, size and mesh vary from model to model. All meshes are colour coded and, in most cases, alternative mesh sizes are available via spray shops.

Red = 32 mesh (course) - not used from the factory.

Blue = 50 mesh

Yellow = 80 mesh

Green = 100 mesh (fine)



PRE-OPERATION CHECK-LIST

Before operating the sprayer:

- Familiarise yourself with all supplied manuals.
- Check the sprayer is securely mounted.
- Check that the spray tank is clean, and drain tap is not open.
- Check that the suction line filter is clean.
- Check the hose reel / spray gun are correctly fitted, and in good condition.
- Fill the hand wash tank (if fitted) with clean fresh water.
- Check all plumbing and fittings are tight and not damaged. Fill the sprayer tank with clean water - making sure the basket filter is in place when filling. Check for leaks.
- **Safety Manual** ... has been read, understood and appropriate preparations have been implemented.

INITIAL START-UP PROCEDURE, MOTORISED SPRAYER

Always use fresh water for familiarisation, maintenance, testing or training. If the unit has seen chemical, always wear safety gloves (as a minimum precaution).

Engine & pump check:

The Honda GX200 engine will have been pre-checked for operation at the factory. However, it is recommended you check the oil level as per the Honda manual.



SECTION 4

PRE-OPERATION, MOTORISED MODELS

Check the oil level in the pump. Pumps, oil requirements and fill positions vary from model to model – check the manual supplied for each unit.



Familiarize yourself with the engine controls – choke, on/off, engine speed control and starter pull-chord.



First Time Start-up

This example is with AR252 pump model. The routine steps are the same – controls will vary from pump to pump and PRV.

- Oil checks done, correct & adequate fuel.
- Fill the sprayer with some clean water (50 litres would be sufficient for initial familiarisation).
- Set the PRV to “Bypass” lever as shown (yellow arrow), and ball valve to the reel in the off position, as shown (blue arrow).

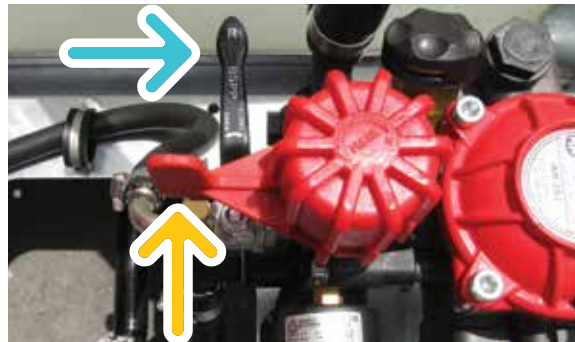

As a starting point set the PRV pressure adjustment knob to approximately 4 turns UP (low pressure). All units are tested and adjusted at the factory before delivery, so take note of the original setting. On AR30 / 40 pumps, set PRV to the first wire – lever up / bypass mode)

- Turn on the Honda’s ignition.
- Set choke to ON. Note hot starts don’t need the choke.
- Set run speed to Minimum (see image)
- Pull Start, usually 2 times is sufficient.
 - o If not starting after 4 or 5 pulls, turn off the choke and set the throttle to full power. Will usually start first time. If all else fails, consult the Honda manual.



- Once the engine is running reliably at approximately ¼ power
 - o Confirm that the pump has primed and is working (flow will be bypassing back to tank).
 - o Turn on the pressure valve, as circled. For the AR30 it’s lever down.

SECTION 4

PRE-OPERATION, MOTORISED MODELS

- o Adjust the pressure until you have the required pressure, say 12 Bar **as circled**.
- o Turn on the ball valve to the hose reel / spray gun / boom, **as circled**.



To Spray

Hold down the hand grip lever of the spray gun. Once the unit is spraying clean water, adjust the engine power until the operating pressure (whilst spraying) is at the required level. While the hand gun is spraying, check that the:

- o Nozzle spray pattern is even, adjusting the spray pattern to suit the application you are planning to carry out.
- o Pump pressure is constant and within the limit of the maximum pressure rating.
- o Release the hand grip lever to stop spraying.



- For spot spraying applications, the required pressure will vary significantly depending on the application and equipment used (boom, lance, gun). Whilst checking the sprayer with fresh water, also check for the maximum pressure likely to be used / checking for leaks etc.

Boom Spraying

The AR30/40/70 sprayers fitted with one hose reel come fitted with 2 taps on the pressure side – one to the spray reel and the other is spare, for another hose reel or maybe a small boom such as Croplands MBX04, (note this is not a factory fitted option).

Turn on the tap to the boom position. Water should now spray from the nozzles. Adjust the spraying pressure to a maximum of 5 bar pressure for boom spraying.

Whilst the pump is running, check all the nozzles to ensure the spray pattern is uniform and check there are no leaks from boom joints, fittings or the nozzle bodies.

For further information on boom spraying, see Section 6 - Spraying Information.



SHUT DOWN

Note see section 5 for more information on **cleaning & flushing**.

Spray to empty

- Always easier to shut down after spraying until the tank and hose lines are empty.
- Reduce engine power to idle.
- Turn off the engine by using the ignition kill switch.
- Turn off the fuel if leaving for some time.



SECTION 4

PRE-OPERATION, MOTORISED MODELS

Shut down with tank partially full

- Reduce engine power to idle.
- Turn off the engine by using the ignition kill switch.
- Use the spray gun to relieve any residual pressure / liquid in the spray line. Do not leave hoses full of water in the heat of summer or the cold of winter.
- If the unit is not going to be used for spraying on the same day, drain the tank and drain the hose.



CAUTION

When the tank becomes empty, the pump will continue to run. Running the pump dry temporarily will not cause damage. However, avoid letting the pump run dry for long periods.

With the initial start-up procedure is successfully completed, the sprayer is ready for operation.

Go to section 5, Operation



SECTION 5

OPERATION

The pre-operation tasks must be completed before commencing spray-operations.

SAFETY FIRST

Before progressing further,

- Read and understand the Safety Manual (part no. GP-SAFE-A) supplied with this sprayer.
- Read and understand this manual to better familiarise yourself with the sprayer.

DAILY START UP PROCEDURE

To ensure trouble free operation, follow the procedure below at the start of each new spray session:

- Check that suction line filter is clean and not damaged. It should be checked & cleaned regularly. Be careful not to damage or deform the mesh or O-Ring while cleaning and refitting the suction line filter. If a filter screen is damaged, replace with a new screen.
- Put enough clean water into the spray tank to operate the pump and hand gun.
- Activate the pump and ensure it primes correctly - hold the spray gun / lance trigger down, until the hand gun sprays steadily.
- Adjust the pressure relief valve to obtain the required pressure. Excess liquid will bypass back to the tank. Once the pressure is set, it is normal for minor fluctuations to show on the pressure gauge when switching the hand gun on & off.
- Check that all hoses, hose clamps and connections do not leak. Repair or replace damaged components.

**CAUTION**

Do not add chemicals to the spray tank until the initial start-up or daily start-up procedure has been carried out. This avoids having a tank full of toxic chemical and the finding a sprayer problem.

- Read and follow the instructions on the chemical manufacturers label before mixing and adding chemicals to the spray tank.
- Add chemical to the tank, as per below and proceed with your spray application.

ADDING CHEMICAL TO THE SPRAY TANK

The steps for adding chemical to the tank are:

1. Calculate the amount of chemical required.
2. Part fill the spray tank with water.
3. Measure and pre-mix the chemical.
4. Add the pre-mixed chemical to the tank.

Step 1: Calculate the Amount of Chemical Required (Also refer Section 6)

To add the correct amount of chemical to a tank, it is necessary to calculate the amount of chemical required.

The method of calculating the amount of chemical required for the sprayer tank is dependent on the chemical rate recommendations. Use the information supplied on the chemical label to determine the tank mix concentration.

If you are unsure of the mix required, ALWAYS check with a qualified advisor or the supplier of the chemical you intend to use.

**CAUTION**

Always follow chemical label instructions. When handling chemicals always wear protective clothing, ie. gloves, face mask, spray suit.

Step 2: Part Fill the Spray Tank with Water

Part fill the sprayer tank with clean water.

Use fresh water (preferably rainwater), free of suspended organic matter or clay. Some chemicals are deactivated when they contact these materials. Ensure water quantity is sufficient to allow correct product blending.

NOTE

Be sure to mix only enough spray mixture to cover the area required. Mixing too much chemical creates unnecessary waste and costs.

**WARNING**

Should chemical come in contact with skin immediately rinse off with water. Always follow chemical label safety instructions.

SECTION 5

OPERATION

Step 3: Measure & Pre-Mix the Chemical

Read and follow the instructions on the chemical manufacturers label before mixing & adding chemicals to the spray tank.

Chemicals should be accurately measured and thoroughly premixed in a separate container before adding to the spray tank:

- Measure out the required liquid chemical in a graduated measuring cylinder or bucket.
- Add chemical to a small volume of water in a container and thoroughly mix the chemical

Tank Agitation

It's important to use chemicals that remain in solution whilst in a TrayPak spray tank. The tank can only be agitated by the bypass side of the Pressure Regulator unit. For this reason, it's important to make sure the pump is generating (slightly) more pressure than required for spraying ... if the pump is not generating enough pressure there will be no bypass/ agitation.

Step 4: Add the Chemical to the Tank

Always make sure the filling basket is in place when adding water or chemical to the tank.

To add the premixed chemical to the tank:

- Add the pre-mixed chemical to the tank, thoroughly rinsing the chemical pre-mix container and adding the rinse to the tank.
- Top up the tank with water to the required volume.
- Close the tank lid securely.

OPERATING THE SPRAY GUN

With the pump operating, and pressure regulator set, to operate the spray gun / spray lance:

- Aim the nozzle at the target area and hold down the hand grip lever to spray the target. Hold down the hand grip lever to spray and check that the:
 - Spray pattern is even.
 - Pump pressure is sufficient.

- If using a variable cone nozzle, adjust the cone to make the spray pattern required.

- Adjust the nozzle as required to completely spray the target.
- Use the hand gun trigger to turn the spray on & off as required.

When finished, switch off the pump. Relieve any residual pressure in the hose with a final use of the spray gun.

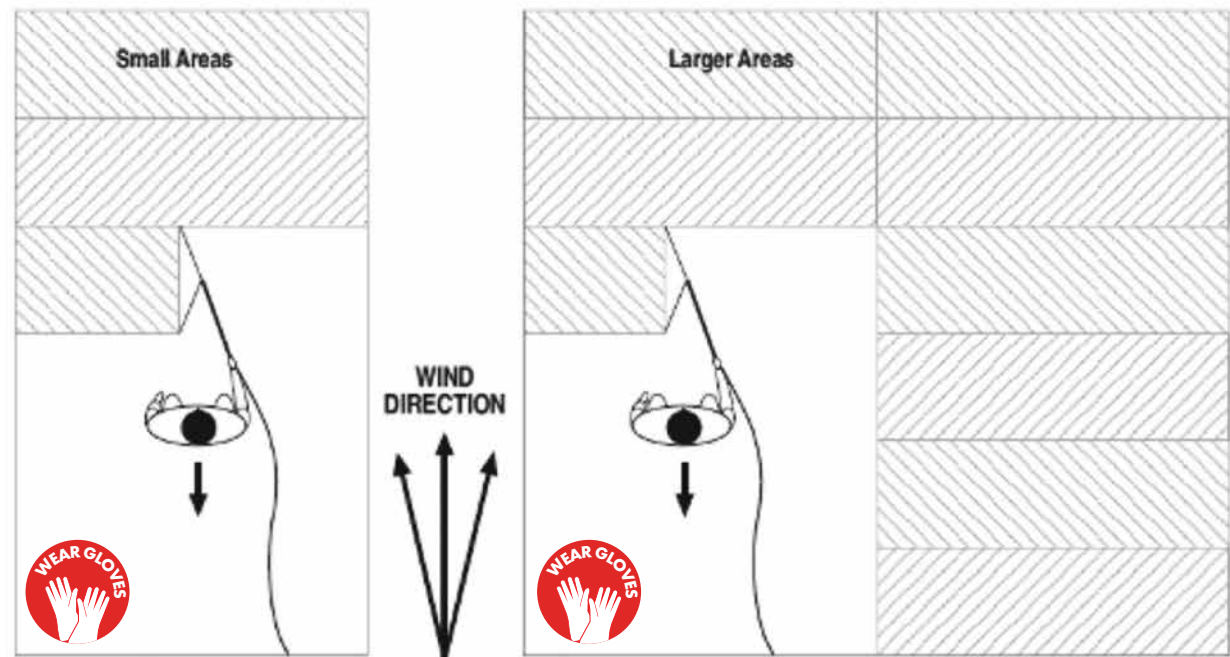

In small areas, spray across the area & move back toward the wind.

In large areas, divide the area into smaller segments & move back toward the wind keeping track of the area sprayed to avoid under or overspraying.

SECTION 5

OPERATION

HAND GUN SPRAYING METHOD

It is always preferable to spray with your back toward the wind direction so that the wind carries spray away from the operator.

The operator should where possible, avoid walking on previously sprayed areas to avoid unnecessary fumes and contamination.

Operate with the sprayer situated behind the operator so that the hose from the sprayer can be kept on unsprayed areas.

This is important because the operator usually must handle, extend and rewind the hose many times, as he shifts from area to area. If the hose is kept relatively free from spray contamination, there is less exposure to chemical contamination.

OPERATING POINTERS

Before spraying, make sure that it is safe to do so.

- The weather conditions must be suitable for hand spraying - always consider the spray drift.
- Be sure that bystanders and children are well away from the spray area and drift zones.
- Consider sign posting the chemical application area.

While spraying continually observe that:

- Adequate operating pressure is being maintained.
- Your hand gun coverage is correct and constant for effective cover.
- The nozzle is operating correctly.
- Periodically check and clean filters.



WARNING

It is recommended to keep the hose from the sprayer on unsprayed ground and uncontaminated from the spray. This minimises contaminants on the hose and minimises exposure to chemicals when handling and rewinding the hose.

- Avoid going too slow because over application will occur. Conversely, avoid going to fast because under application will occur.

BOOM SPRAYING

Some customers will fit out their TrayPak sprayers with a small boom, such as Croplands MBX04. For further information on boom spraying, see Section 6 - Spraying Information.

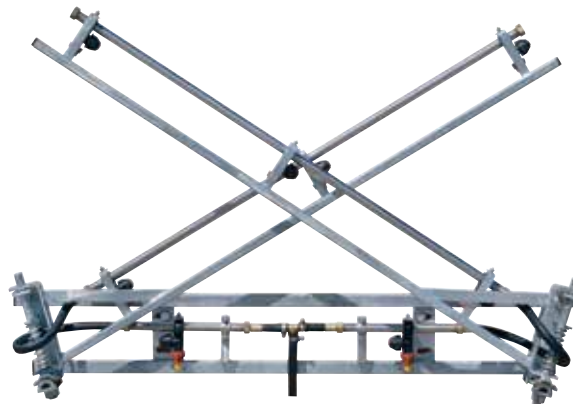

EMERGENCY ACTION PLAN

Never operate the sprayer without an action plan in place for when things go wrong ...

“Take 5” to evaluate the risks

Actions for most foreseeable machine issues such as breakages start with ...

“Drop the speed”

“Dump the pressure”

then evaluate further.

SECTION 5

OPERATION

CLEAN & FLUSH THE SPRAYER

The TrayPak sprayer should be thoroughly cleaned and flushed:

- Between chemical changes, and
- At the end of each day's spraying.

To completely flush and clean the sprayer:

- Remove the tank drain plug to drain spray mixture from the tank.
- Ensure drained mixture is disposed of as required by law. Read the chemical instructions.
- After chemicals have drained from the main tank, thoroughly rinse out the tank. Thoroughly clean the suction line filter & reassemble.
- Close the tank drain valve and add clean water to the tank to thoroughly flush the lines, pump and spray gun (and /or boom if fitted). Switch On the pump.
- Hold down the hand grip lever until all mixture is flushed out of the hose and hand gun / lance.
- On completion of flushing, release the trigger of the hand gun and turn the power switch off.
- Repeat steps 1 to 7 to more completely remove chemical residue from the tank and sprayer system.
- Wash/hose down the outside of the sprayer.



CAUTION

Always ensure the site for flushing and cleaning the sprayer meets with environmental and statutory regulations.

USING TANK & EQUIPMENT CLEANERS

If a cleaning agent is required (refer to chemical label), first completely flush the Sprayer with water as outlined previously.

To use the tank & equipment cleaner:

- Fill the spray tank approximately half full of freshwater.
- Add cleaning agent (use according to the manufacturer's instructions).
- Switch on the pump.
- Place the lance into the tank and hold down the hand grip lever to circulate cleaning fluid through the suction line, pressure line, hand gun and back to the tank.
- If you require the cleaning agent to soak or stand for a period, shut off the hand gun by releasing the hand grip lever and switch the power off.
- When soaking is completed, start the sprayer following steps 3 & 4 to flush the suction lines, pressure lines and hand gun.
- Stop flushing by releasing the hand grip lever and then switch the power off.
- Remove the spray tank drain plug and allow cleaning mixture to drain from the tank.
- Again, completely flush the sprayer with fresh water as outlined previously.
- Check the filter to ensure scale deposits are removed from the filter if they are present. Often the cleaning agent will dislodge chemical build-up from spray lines and fittings.

The Tank & Equipment Cleaner as pictured is no longer available. Comparable cleaners are available from most good "spray shops".



CAUTION

If you experience heavy frosts in your area, run the pump until the spray lines are dry after use. This will prevent damage from water freezing in the spray lines and pump.



ALWAYS FLUSH PUMP WITH FRESH WATER AFTER USE

Failure to flush with fresh water may result in damage to the pump and reduced pump performance.

CROPLANDS



SECTION 6

SPRAYING INFORMATION & CALIBRATION

WHEN TO SPRAY

Spraying results are best when the wind speed and the temperature are low, but the relative humidity is reasonably high. An ideal time is at sun up or nearing the end of the day when these conditions are more likely to occur.

For more information, contact Croplands about our SprayWise® program, or purchase a copy of the Nufarm SprayWise Application Guide from Croplands.

Also, the use of the WINDMATE™ Wind meter would be of excellent value to anyone doing regular spraying.

USEFUL FORMULA

Calculating the Tank Spray Area

Use this formula to calculate the area each tank full of spray will cover.

$$\text{Area Covered (ha)} = \frac{\text{Tank Volume (litres)}}{\text{Spray Application Rate (l/ha)}}$$

e.g. $\frac{250}{100} = 2.5 \text{ hectares}$

Calculating the Total Liquid Volume Required

Use this formula to calculate the amount of spray liquid required to spray a given area.

$$\text{Total Liquid Volume Required (litres)} = \text{Area (ha)} \times \text{Spray Application Rate (l/ha)}$$

e.g. $2 \times 100 = 200 \text{ litres}$

CALIBRATION - GENERAL

We should strive for the most efficient use of spray chemicals for effective pest and disease control. Consumer and public pressures to minimise residues, requires us to achieve the target application rate (uniform spray coverage without over or under spraying).

Applying the correct amount of chemical to a crop is only possible if the:

- Sprayer is calibrated correctly.
- Sprayer is maintained / operated correctly.

Correct chemical application rate can only be achieved if the variables of spray application are measured and controlled:

- Distance, time & working width are measured.
- Liquid & chemical volume applied.

This is done through sprayer calibration. Sprayer calibration is one of the single most important factors in establishing the correct application rate of the sprayer. Without calibration it is not possible to know the actual rate of spray application.

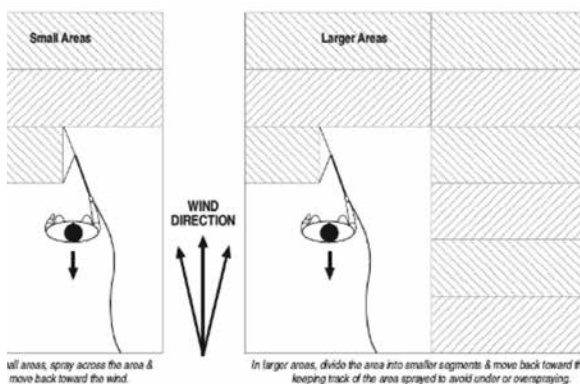

SPOT SPRAYER CALIBRATION

See section 5 for hand gun / lance spraying method.

TrayPak sprayers are most commonly used for spot spraying using a hand gun with a single variable cone or flat fan nozzle.

Precise application rates are not usually achieved with hand guns because the application rate is entirely dependent on the operator.

Two steps are recommended for calibrating a spot sprayer:

1. Choose the appropriate nozzle.
2. Check the nozzle operates correctly.

Choose the Appropriate Nozzle.

The nozzles used should be appropriate for the chemical being used. The standard adjustable ConeJet should suffice for general Glyphosate-based formulations & applications. Follow the chemical manufacturer's recommendation for any specific nozzle requirements as per the manufacturers label.

The standard lance has a removable cap, the adjustable ConeJet can be removed and most 80 and 110degree flat fan nozzles can then be used with the cap & seal.

The nozzle chosen must be within the flow capability of the pump fitted to the sprayer.



The Honda powered pumps have ample performance for most spray gun applications. The Turbo 400 gun comes standard with a 1.5mm nozzle. See chart overleaf for performance.

SECTION 6

SPRAYING INFORMATION & CALIBRATION

Pressure	15 Bar (200 psi)		25 Bar (350 psi)		35 Bar (500 psi)		40 Bar (600 psi)	
	Cone	Straight	Cone	Straight	Cone	Straight	Cone	Straight
Spray pattern								
Flow (L/Min)	4.6	5.1	5.7	6.5	6.6	7.4	6.9	7.8
Spray Angle (Degree)	25	x	28	x	28	x	28	x
Max Throw (Metre)	3	7	3.2	7.8	3.4	8.5	3.5	9.2

SPRAY QUALITY

Spray quality is becoming extremely important for the correct application of chemicals. Refer to your advisor, local DPI or check the Croplands Buyers Guide for more information.

Many chemical labels now specify the spray quality required for the product being used. Loosely, spray quality falls into a droplet range of:

- » Ultra Coarse
- » Very Coarse
- » Medium
- » Very fine
- » Extremely Coarse
- » Coarse
- » Fine

NOTE

Most spray applications will fall into the Medium to Very Coarse range, depending on the application. Talk to a qualified Agronomist or advisor if uncertain.

BOOM SPRAYING

Some customers will fit out their TrayPak sprayers with a small boom, such as Croplands MBX04. Note this is NOT a factory fitted option, and hence boom spraying is not covered in full by this manual.

Each Croplands boom comes supplied with a user manual and are fitted standard with non-drip nozzle bodies so that when the liquid flow is switched off, the nozzles will not drip. These booms are fitted with AirMix[®] air-induction ultra-low drift nozzles.

To ensure the right application of herbicide or crop protection product is applied to the target crop, the user should calibrate the boom to ensure the correct application rate is used for the chemical being used.

The spray target rate and spray quality information are usually supplied by the chemical manufacturer on their product label. Alternatively, a trained agronomist should be consulted.

Liquid flow to the boom can be stopped & started as

required by using a remote PRV (Pressure Control Unit) such as pictured (ARGi40 shown) or tap to the boom. Note this is NOT a factory fitted option.



SECTION 7

MAINTENANCE & TROUBLESHOOTING

DAILY MAINTENANCE

In the first few days of sprayer usage, thoroughly check the machine before starting each day of spraying.

- Check all nuts, bolts and tank tie downs.
- Check plumbing for leaks.
- Check all safety guards and decals are in place.

Pump - Honda-powered AR models

- Check the oil level on the pump sight gauge and top up with SAE 20/40 multi grade engine oil if needed.

Filters

- It is important to clean filters daily as they can have a major impact on your sprayer's performance. Wash them out with a soft brush and constantly check for holes or tears. Clean the suction filter every time the tank is filled and at the end of the days spraying. Make sure O rings are in good condition and grease them with O ring grease in necessary. Clean out nozzle filters if installed.

Spray lines

- Never leave chemicals in the tank or the pump. Rinse the tank out completely with fresh water and operate machine to clear all spray lines. Remove boom tube caps if you have a boom fitted and flush the boom lines.

20 HOURS MAINTENANCE

- Grease the reel swivel if fitted / needed.

NOTE

Also refer to your Honda Manual supplied with your sprayer for engine maintenance.

ANNUAL MAINTENANCE

In addition to daily maintenance.

General sprayer care

When spraying season has finished, clean the machine completely.

- For winter storage, if freezing conditions are expected, empty pump completely and flush with a mixture of water and antifreeze to prevent unrepairable damage to your unit.

Pump - Honda-powered AR models

- Flush and drain the pump completely before storage.
- Check the valves and diaphragms for wear and damage before the start of the new season. Set the air pressure in the chamber to around 10 – 20% of the usual operating pressure.



Do not leave water in the machine, particularly in cooler climes as this can freeze and ruin the pump.

- Drain the oil before the commencement of the next season and replace completely with new oil (SAE 20/40 multi grade engine oil).

SECTION 7

MAINTENANCE & TROUBLESHOOTING

Troubleshooting Pump Problems

PROBLEM	PROBABLE CAUSE	REMEDY
A. Failure to Prime - motor operates, but no pump discharge.	1. Restriction in intake or discharge line.	1. Open all line valves, check for "jammed" check valve poppets & clean clogged lines.
	2. Air leak in intake line.	2. Fix air leak in intake line.
	3. Punctured pump diaphragm.	3. Replace pump diaphragm.
	4. Defective pump check valve.	4. Repair or replace pump check valve.
	5. Crack in pump housing.	5. Replace pump housing.
	6. Debris in filter or check valve.	6. Clean filter or check valve.
B. Motor Fails to Start	1. Consult the Honda owners manual	 <p>The image shows the cover of the Honda Owner's Manual for the GX200 engine. The cover features the Honda logo at the top, followed by the text 'OWNER'S MANUAL', 'MANUEL DE L'UTILISATEUR', and 'MANUAL DEL PROPIETARIO'. Below this, the model 'GX200' is displayed above a small illustration of the engine. On the right side, there are two vertical labels: 'ENGLISH' and 'FRANCAIS'.</p>
C. Low Flow and Pressure	1. Blocked suction filter.	1. Clean the suction filter.
	2. Air leak at pump intake.	2. Repair air leak on the pump intake.
	3. Accumulation of debris inside pump & plumbing.	3. Clean the inside of the pump and plumbing.
	4. Worn pump bearing (excessive noise).	4. Replace pump bearing.
	5. Punctured pump diaphragm.	5. Replace pump diaphragm.
	6. Defective rectifier or motor.	6. Replace rectifier or motor.
D. Pulsating Flow - Pump Cycling On and Off.	1. Restricted pump delivery.	1. Check discharge lines, fittings, valves & spray nozzles for clogging or undersizing.
	2. Nozzle too small.	2. Ensure nozzle is correct size.
E. Motor stops unexpectedly	1. Run out of fuel	1. Allow motor to cool down before topping up with fuel & restarting.

SECTION 8

ASSEMBLY DRAWINGS

ALL PARTS INFORMATION is now listed on the Croplands website:

- Go to croplands.com.au
- Search in the Parts Information section linked to the home page.

NOTE

Drawings are for illustration purpose only - refer to sprayer for actual plumbing. Parts listed are indicative of the sprayer type.
Items in italics or without a part number are non stocked items and may need to be specially ordered.
For further parts information refer to: www.croplands.com.au

NOTE

Contact Croplands Technical Support for further information:
1300 650 724

200F / 300F BASE ASSEMBLY	31
US20F/252/HR30	32
US30F/30/HR30TG	33
600F BASE ASSEMBLY	34
US60F/40/TWIN	35
US500/70/HR30TG	36

SECTION 8

ASSEMBLY DRAWINGS

200F/300F BASE ASSEMBLY

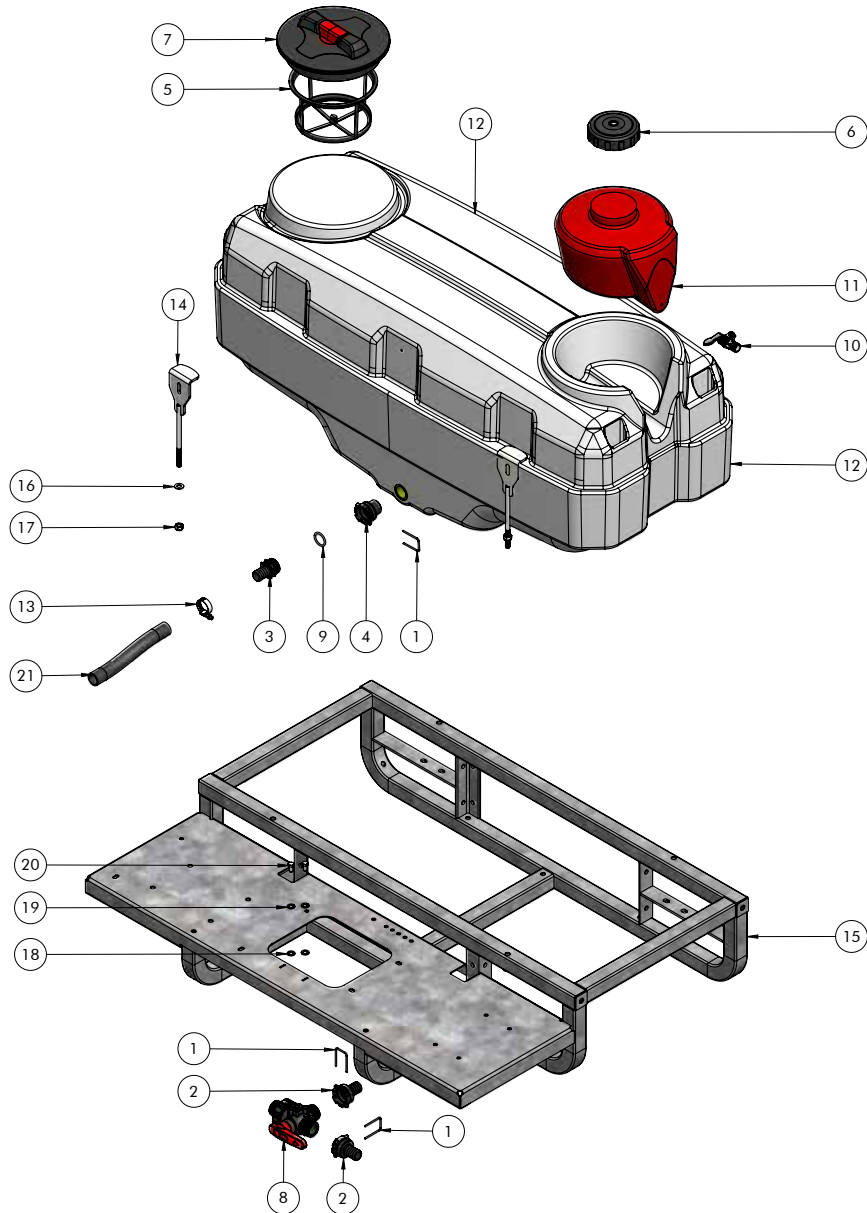

ITEM NO.	PART NUMBER	DESCRIPTION	QTY.
1	A010004	MANIFOLD FORK T4	3
2	A1090425	HOSETAIL 25MM	2
3	A1091425	HOSETAIL T4M D.25	1
4	A249044	HOSETAIL T4F 1"MALE	1
5	A300110	FILTER BASKET SMALL 115MM DEEP	1
6	A354030	LID 4" C/W BREATHER & SEAL	1
7	A3510221	LID/RING KIT 250MM G8149000	1
8	A45524444	BALL VALVE 3 WAY T4M	1
9	AG11054	O RING 25MM	1
10	B165.1501.5	BALL VALVE 1/2" X 1/2" RH	1
11	P200C-6L-RAW	TANK 6LT RTV HANDWASH	1
12	P200C-RAW	TANK 200LT RTV	1
	P300C-RAW	TANK 300LT RTV	option
13	TR1HC	HOSE CLAMP 25MM 1" WORM DRIVE	2
14	UP-306-2	TIE DOWN CLAMP 200/300	4
15	UP-307-1	FRAME TRAYMOUNT 200/300	1
16	M10FWASHER	M10 FLAT WASHER ZP	4
17	M10NNUT	M10 NYLOC NUT HT ZP	4
18	M8FWASHER	M8 FLAT WASHER ZP	2
19	M8SWASHER	M8 SPRING WASHER ZP	2
20	M8X16	M8 X 16 SET SCREW HT ZP	2
21	Tube_1-US200-FM1A	HEP25 SUCTION HOSE	235MM

NOTE

Drawings are for illustration purpose only - refer to sprayer for actual plumbing. Parts listed are indicative of the sprayer type.

Items in *italics* or without a part number are non stocked items and may need to be specially ordered.

For further parts information refer to: www.croplands.com.au

Please contact Technical support for further details

SECTION 8

ASSEMBLY DRAWINGS

US20F/252/HR30

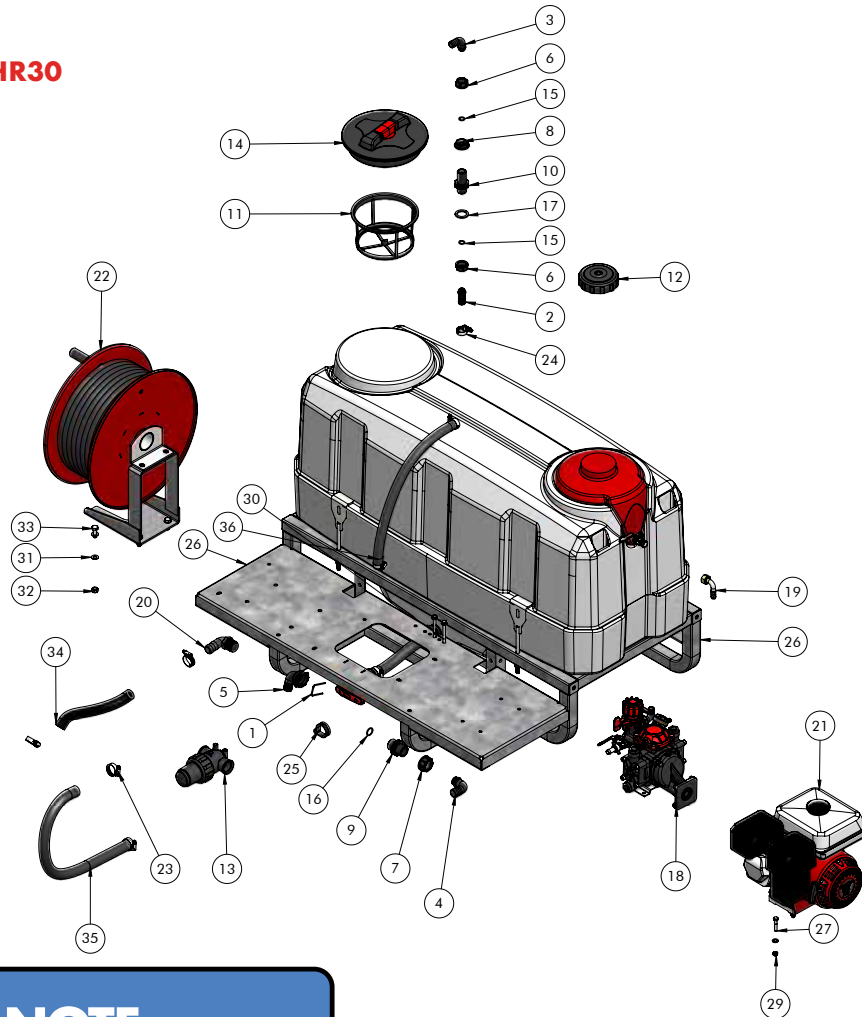

NOTE

Drawings are for illustration purpose only - refer to sprayer for actual plumbing. Parts listed are indicative of the sprayer type.

Items in *italics* or without a part number are non stocked items and may need to be specially ordered.

For further parts information refer to: www.croplands.com.au

ITEM NO.	PART NUMBER	DESCRIPTION	QTY.
1	A010004	MANIFOLD FORK T4	1
2	A106320	TAIL 3/4" TO 20MM	1
3	A116320	ELBOW 3/4"	1
4	A116425	ELBOW 0.25 FOR FLY	1
5	A1190425	ELBOW T4F D.25	1
6	A200030	FLY NUT 3/4"	2
7	A200040	FLY NUT 1"	1
8	A205030	BACK NUT 3/4"	1
9	A250040	NIPPLE 1"	1
10	A2502031	LONG THREAD NIPPLE 3/4"	1
11	A300110	FILTER BASKET SMALL 115MM DEEP	1
12	A354030	LID 4" C/W BREATHER & SEAL	1
13	A3244043	FILTER 1" 50MESH FEMALE THREAD	1
14	A3510221	LID/RING KIT 250MM	1
15	AG10031	O RING 3/4"	2
16	AG10041	O RING 1"	1
17	AG40003	FLAT SEAL 3/4" EPDM	1
18	AR252-CRGI	PUMP W/ GEARBOX & CONT 30826	1
19	B163.604.13	ELBOW 1/2" C/W HEX NUT 1/2"	1
20	BJHB100-90	ELBOW 1" - 1" BARB	1
21	GX200QX	MOTOR 6.5HP HONDA	1
22	L-R1412	HOSE REEL B/M 30M X 10MM T_GUN	1
23	TR1HC	HOSE CLAMP 25MM 1" WORM DRIVE	4
24	TR34HC	HOSE CLAMP 20MM 3/4" WORM DRIVE	3
25	TRSGU138W5	P CLAMP 38MM RUBBER SLEEVE S/S	1
26	US300-FM1A	TANK AND FRAME 300LT RTV V2	1
27	M8X40BOLT	M8 X 40 HEX HEAD BOLT HT ZP	4
28	M8FWASHER	M8 FLAT WASHER ZP	12
29	M8NNUT	M8 NYLOC NUT HT ZP	6
30	M8X85BOLT	M8 X 85 HEX HEAD BOLT HT	2
31	M10FWASHER	M10 FLAT WASHER ZP	8
32	M10NNUT	M10 NYLOC NUT HT ZP	4
33	M10X30	M10 X 30 SET SCREW HT ZP	4
34	Tube_2-US200_30_HR30TG	HEP25 SUCTION HOSE	1
35	Tube_3-US200_30_HR30TG	HEP25 SUCTION HOSE	1
36	Tube_4-US300_30_HR30TG	HEP25 SUCTION HOSE	1

Please contact Technical support for further details

SECTION 8

ASSEMBLY DRAWINGS

US30F/30/HR30TG

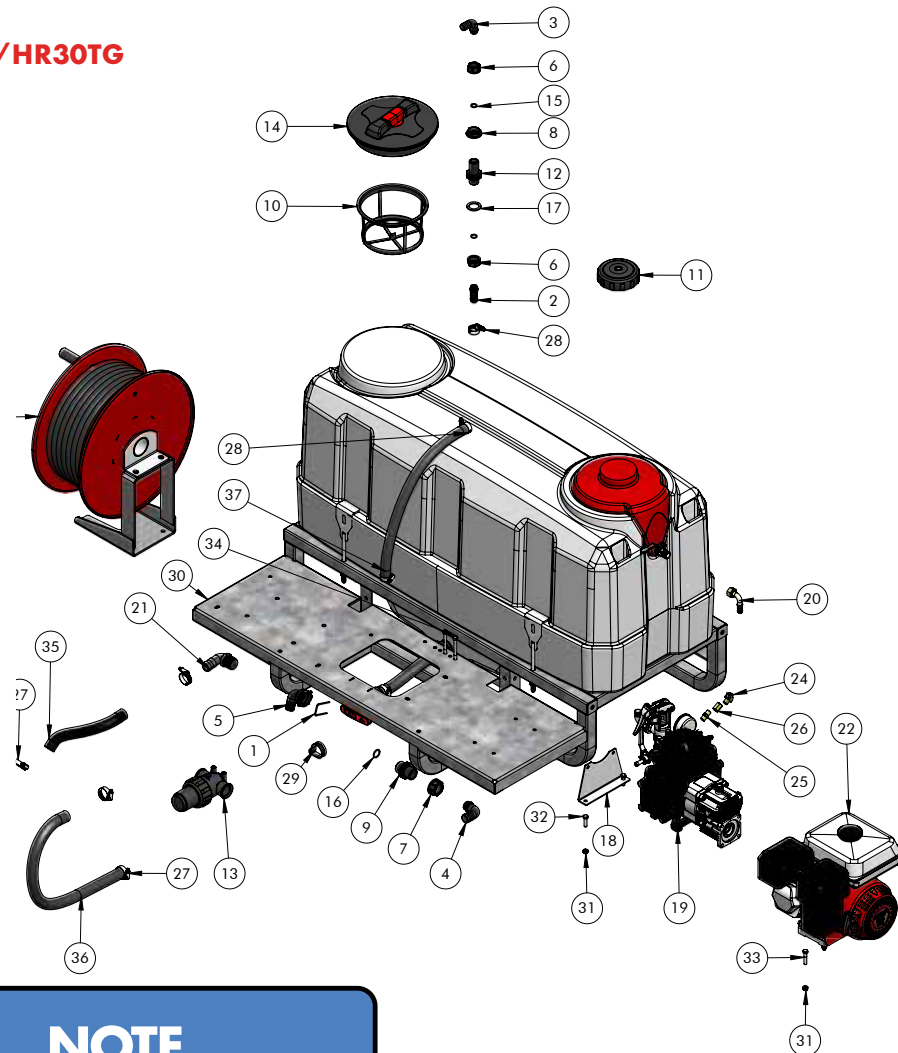

NOTE

Drawings are for illustration purpose only - refer to sprayer for actual plumbing. Parts listed are indicative of the sprayer type.

Items in *italics* or without a part number are non stocked items and may need to be specially ordered.

For further parts information refer to: www.croplands.com.au

ITEM NO.	PART NUMBER	DESCRIPTION	QTY.
1	A010004	MANIFOLD FORK T4	1
2	A106320	TAIL 3/4" TO 20MM	1
3	A116320	ELBOW 3/4"	1
4	A116425	ELBOW 0.25 FOR FLY	1
5	A1190425	ELBOW T4F D.25	1
6	A200030	FLY NUT 3/4"	2
7	A200040	FLY NUT 1"	1
8	A205030	BACK NUT 3/4"	1
9	A250040	NIPPLE 1"	1
10	A2502031	LONG THREAD NIPPLE 3/4"	1
11	A300110	FILTER BASKET SMALL 115MM DEEP	1
12	A354030	LID 4" C/W BREATHER & SEAL	1
13	A3244043	FILTER 1" 50MESH FEMALE THREAD	1
14	A3510221	LID/RING KIT 250MM	1
15	AG10031	O RING 3/4"	2
16	AG10041	O RING 1"	1
17	AG40003	FLAT SEAL 3/4" EPDM	1
18	AR30BRKT	AR30 MOTORISED PUMP STAND	1
19	AR40_CRGI	PUMP AR40 GEARBOX &CONT	1
20	B163.604.13	ELBOW 1/2" C/W HEX NUT 1/2"	2
21	BJHB100-90	ELBOW 1" - 1" BARB	1
22	GX200QX	MOTOR 6.5HP HONDA	1
23	L-R1412	HOSE REEL B/M 30M X 10MM T_GUN	1
24	TFEL14MF45DEG	ELBOW 1/4" M/F 45DEGREE	1
25	TFM1414	NIPPLE 1/4" BRASS	1
26	TFS1414	SOCKET 1/4" BSPF	1
27	TR1HC	HOSE CLAMP 25MM 1" WORM DRIVE	4
28	TR34HC	HOSE CLAMP 20MM 3/4" WORM DRIVE	3
29	TRSGU138W5	P CLAMP 38MM RUBBER SLEEVE S/S	1
30	US300-FM1A	TANK AND FRAME 300LT RTV V2	1
31	M8NNUT	M8 NYLOC NUT HT ZP	8
32	M8X30	M8 X 30 SET SCREW HT ZP	2
33	M8X40BOLT	M8 X 40 HEX HEAD BOLT HT ZP	4
34	M8X85BOLT	M8 X 85 HEX HEAD BOLT HT	2
35	Tube_2-US200_30_HR30TG	HEP25 SUCTION HOSE	248mm
36	Tube_3-US200_30_HR30TG	HEP25 SUCTION HOSE	691mm
37	Tube_4-US300_30_HR30TG	HEP25 SUCTION HOSE	550mm

Please contact Technical support for further details

SECTION 8

ASSEMBLY DRAWINGS

600F BASE ASSEMBLY

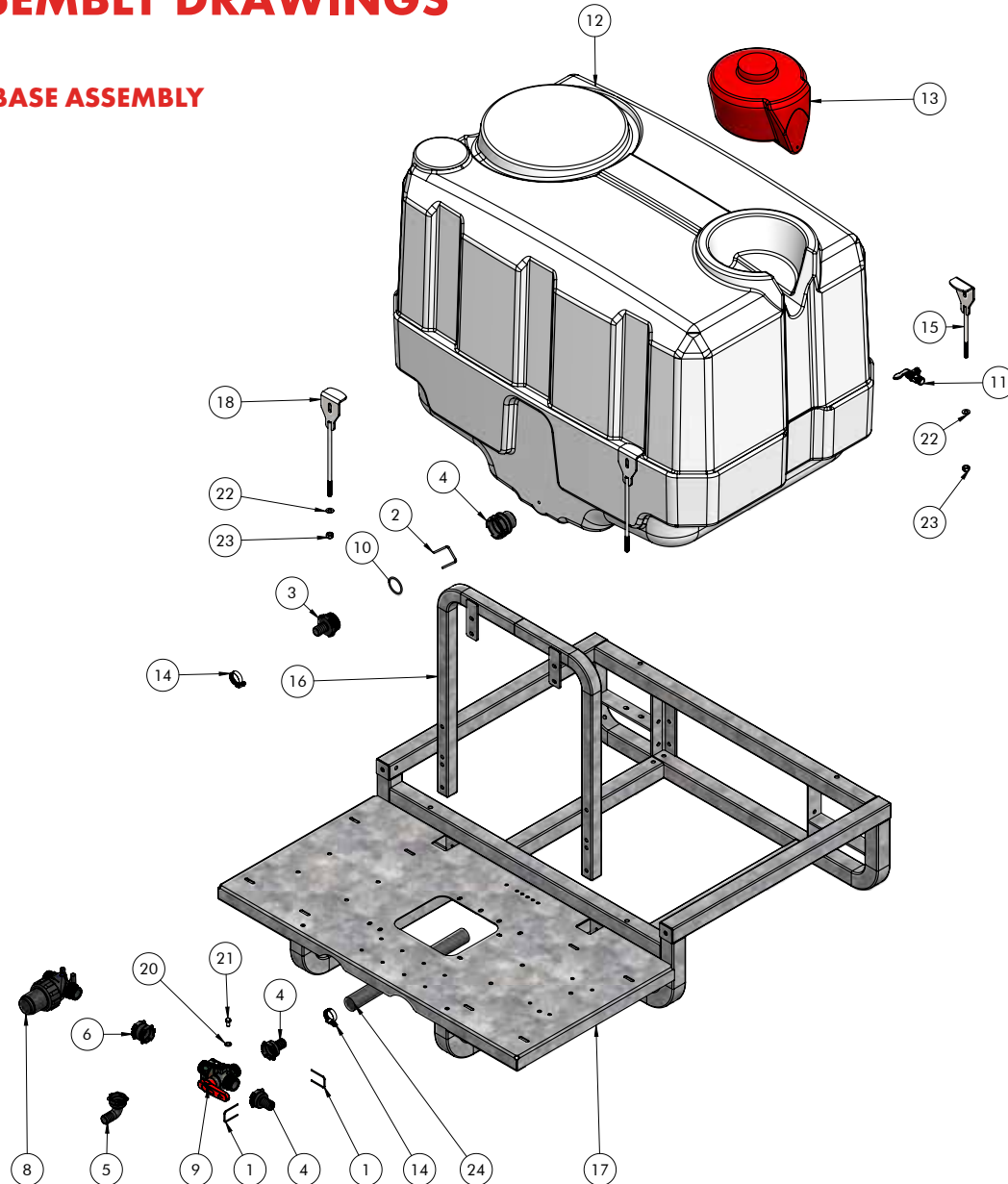

ITEM NO.	PART NUMBER	DESCRIPTION	QTY.
1	A010004	MANIFOLD FORK T4	2
2	A010006	FORK 453 SERIES T6	1
3	A1091625	HOSE BARB T6M TO 1" BARB STRAIGHT	1
4	A1090425	HOSETAIL 25MM	2
5	A1190425	ELBOW T4F D.25	1
6	A259044	SOCKET T4F	1
4	A249066	OUTLET 1 1/2" MALE 453 SERIES	1
8	A32240C3	LINE FILTER	1
9	A45524444	BALL VALVE 3 WAY T4M	1
10	AG11023	O RING	1
11	B165.1501.5	BALL VALVE 1/2" X 1/2" RH	1
12	P600B-RAW	TANK 600LT RTV	1
13	P200C-6L-RAW	TANK 6LT RTV HANDWASH	1
14	TR1HC	HOSE CLAMP 25MM 1" WORM DRIVE	2
15	UP-306-2	TIE DOWN CLAMP 200/300	2
16	UP-306-5	HOSE REEL BRACKET	1
17	UP-308-1	RTV FRAME 600LT V2	1
18	UP-308-2	TIE DOWN CLAMP 600	2
19	M8FWASHER	M8 FLAT WASHER ZP	2
20	M8SWASHER	M8 SPRING WASHER ZP	2
21	M8X16	M8 X 16 SET SCREW HT ZP	2
22	M10FWASHER	M10 FLAT WASHER ZP	4
23	M10NNUT	M10 NYLOC NUT HT ZP	4
24	Tube	HEP25 SUCTION HOSE	450

NOTE

Drawings are for illustration purpose only - refer to sprayer for actual plumbing. Parts listed are indicative of the sprayer type.

Items in *italics* or without a part number are non stocked items and may need to be specially ordered.

For further parts information refer to: www.croplands.com.au

SECTION 8

ASSEMBLY DRAWINGS

US60F/40/TWIN

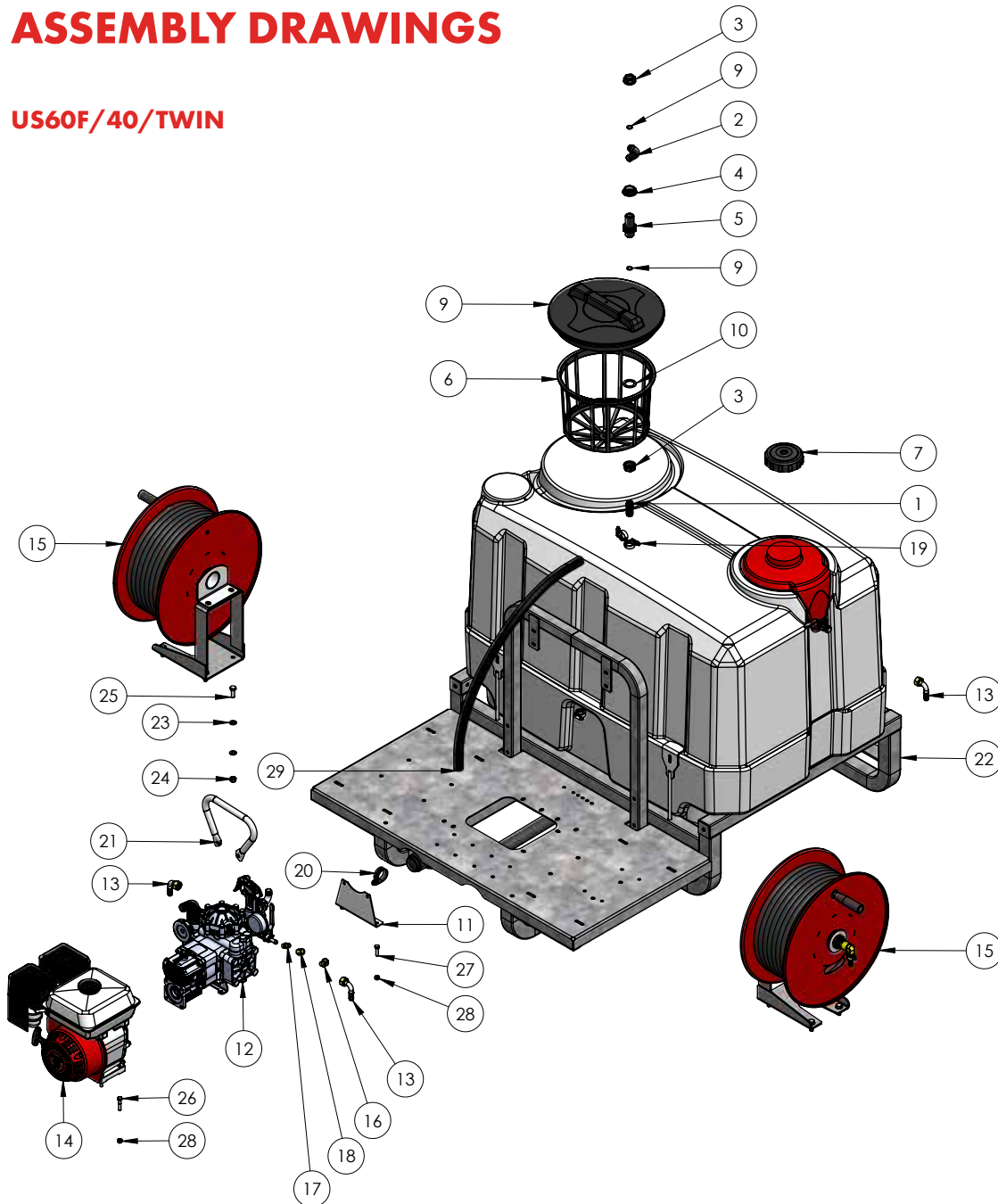

ITEM NO.	PART NUMBER	DESCRIPTION	QTY.
1	A106320	TAIL 3/4" TO 20MM	1
2	A116320	ELBOW 3/4"	1
3	A200030	FLY NUT 3/4"	2
4	A205030	BACK NUT 3/4"	1
5	A2502031	LONG THREAD NIPPLE 3/4"	1
6	A300120	FILTER BASKET MEDIUM 254MM DEEP	2
7	A354030	LID 4" C/W BREATHER & SEAL	1
9	A3510040	LID/RING KIT 355MM	1
9	AG10031	O RING 3/4"	2
10	AG40003	FLAT SEAL 3/4" EPDM	1
11	AR30BRKT	AR30 MOTORISED PUMP STAND	1
12	AR40_CRGI	PUMP AR40 GEARBOX & CONT	1
13	B163.604.13	ELBOW 1/2" C/W HEX NUT 1/2"	3
14	GX200QX	MOTOR 6.5HP HONDA	1
15	L-R1412	HOSE REEL B/M 30M X 10MM T_GUN	2
16	TFEL14MF45DEG	ELBOW 1/4" M/F 45DEGREE	1
17	TFM1414	NIPPLE 1/4" BRASS	1
18	TFS1414	SOCKET 1/4" BSPF	1
19	TR34HC	HOSE CLAMP 20MM 3/4" WORM DRIVE	3
20	TRSGU138W5	P CLAMP 38MM RUBBER SLEEVE S/S	1
21	UPHANDLE	HANDLE FOR MOTORISED AR19/30	1
22	US600-FM1A	TANK AND FRAME 600RTV V2	1
23	M10FWASHER	M10 FLAT WASHER ZP	16
24	M10NNUT	M10 NYLOC NUT HT ZP	8
25	M10X30	M10 X 30 SET SCREW HT ZP	8
26	M8X40BOLT	M8 X 40 HEX HEAD BOLT HT ZP	4
27	M8X30	M8 X 30 SET SCREW HT ZP	2
28	M8NNUT	M8 NYLOC NUT HT ZP	6
29	Tube_4-US600_30_HR30TG	HEP25 SUCTION HOSE	700MM

NOTE

Drawings are for illustration purpose only - refer to sprayer for actual plumbing. Parts listed are indicative of the sprayer type.

Items in *italics* or without a part number are non stocked items and may need to be specially ordered.

For further parts information refer to: www.croplands.com.au

Please contact Technical support for further details

SECTION 8

ASSEMBLY DRAWINGS

US500/70/HR30TG

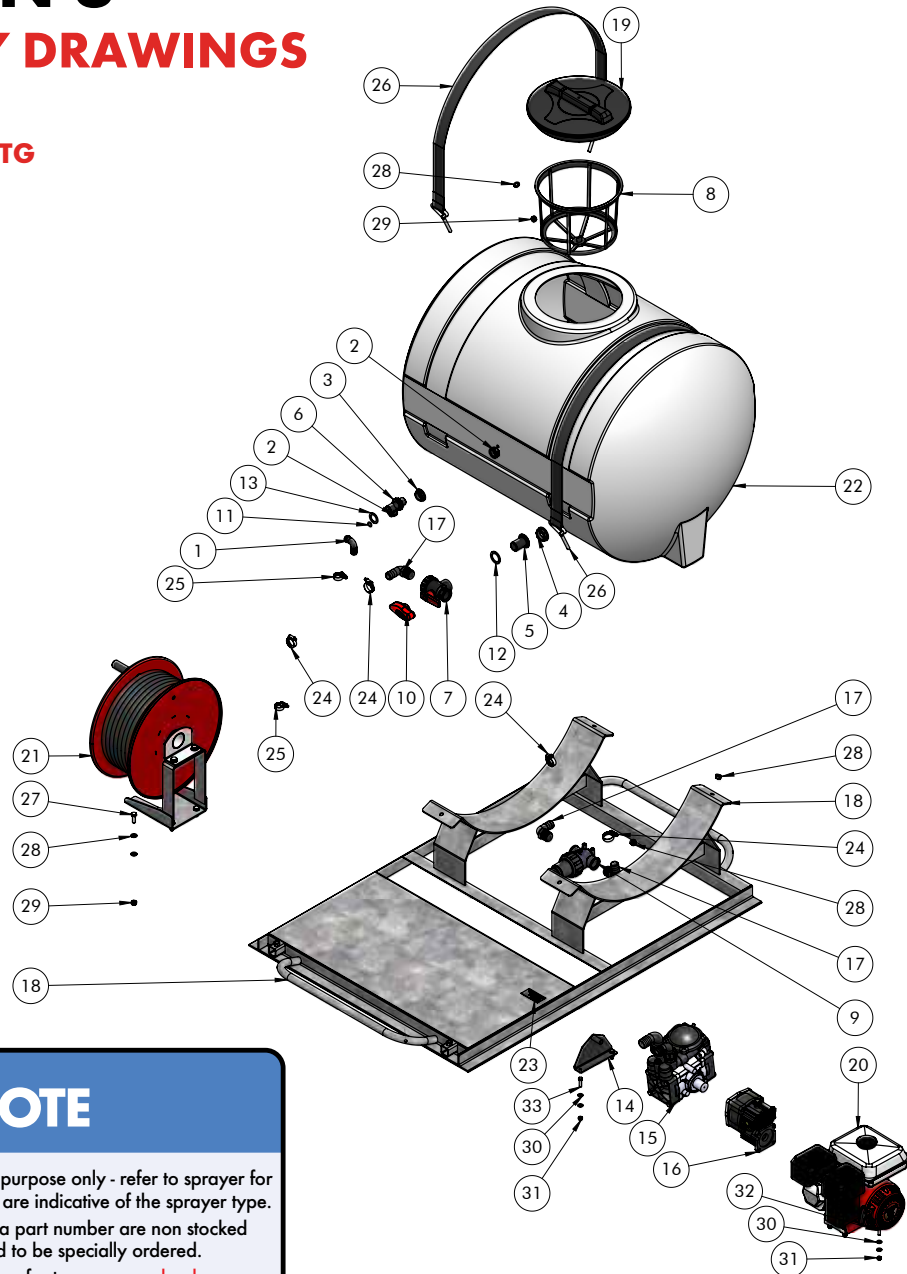

ITEM NO.	PART NUMBER	DESCRIPTION	QTY.
1	A116320	ELBOW 3/4"	2
2	A200030	FLY NUT 3/4"	2
3	A205030	BACK NUT 3/4"	1
4	A205040	BACK NUT 1"	1
5	A220040	TANK OUTLET 1"	1
6	A2502031	LONG THREAD NIPPLE 3/4"	1
7	A454234	BALL VALVE POLY 1" 3 WAY	1
8	A300120	FILTER BASKET MEDIUM 254MM DEEP	1
9	A3244043	FILTER 1" 50MESH FEMALE THREAD	1
10	A45300400T.050	T HANDLE VALVE RED DN25	1
11	AG10031	O RING 3/4"	2
12	AG40004	FLAT SEAL 1" EPDM	1
13	AG40015	FLAT GASKET 27.5X39.5X5 EPDM	1
14	AR60BRKT	AR70/115 MOTORISED PUMP STAND	1
15	AR70-SP	PUMP AR70SP (BARE SHAFT) 30792	1
16	AR1671	GEARBOX (AR70/115/120 1:5.9)	1
17	BJHB100-90	ELBOW 1" - 1" BARB	3
18	BP-221BA	SKID CHASSIS 550LT	1
19	G8155000	LID/RING KIT 355MM	1
20	GX200QX	MOTOR 6.5HP HONDA	1
21	L-R1412	HOSEREEL B/M 30M X 10MM T-GUN	1
22	P600-RAW	TANK 550LT POLY RAW W/O FITTING	1
23	S/NO	SERIAL NUMBER PLATE	1
24	TR1HC	HOSE CLAMP 25MM 1" WORM DRIVE	4
25	TR34HC	HOSE CLAMP 20MM 3/4" WORM DRIVE	3
26	XTRAP1800	TANK STRAP 1800MM	2
27	M10X30	M10 X 30 SET SCREW HT ZP	4
28	M10FWASHER	M10 FLAT WASHER ZP	12
29	M10NNUT	M10 NYLOC NUT HT ZP	8
30	M8FWASHER	M8 FLAT WASHER ZP	12
31	M8NNUT	M8 NYLOC NUT HT ZP	6
32	M8X40BOLT	M8 X 40 HEX HEAD BOLT HT ZP	4
33	M8X30	M8 X 30 SET SCREW HT ZP	2

NOTE

Drawings are for illustration purpose only - refer to sprayer for actual plumbing. Parts listed are indicative of the sprayer type.

Items in *italics* or without a part number are non stocked items and may need to be specially ordered.

For further parts information refer to: www.croplands.com.au

SECTION 9

INDEX

Agitation 14 (D & E), 15, 16, 19, 23

Assembly drawings & parts 30 ~ 35

Ball valve 15, 17, 25

Booms & boom spraying 20, 24, 27

Bystanders and children Safety Manual, 6

Calculate chemical quantities 22

Calibration 26

Checklist (pre operating) 18 ~ 20, 22

Chemical disposal Safety Manual, 6, 15, 18, 25

Chemicals – working with - Safety Manual, 22 ~ 25

Chemicals – adding to tank 22, 23

Cleaning the sprayer 25

Contents 3, 13, 30

Croplands customer support - back cover

Croplands technical support 30

Croplands web site - back cover

Daily start-up procedure 22

Date of publication 4

Dimensions 11, 12

Disclaimer 2

Drain 7, 15, 17, 25

Emergency action plan 24

Fill main tank 17, 22, 23

Filters 17, 18, 28, 7, 14, 17, 18, 28

First time start-up 18 ~ 20

Flushing after spraying 25

Fresh water 17, 18, 22

Gloves & PPE Safety Manual, 22, 25

Hand Gun - 9, 16, 17, 20, 23, 26, 27

Hand wash tank & tap 7, 11, 22,

Hook-up 14, 18

Hose reel 9 ~ 12, 14, 24

Important information 4, 5, 6

Introduction 2

Lids & Lid basket 7, 14, 17, 18, 28

Load & unloading 6, 14

Main tank 7, 10 ~ 12, 17, 21, 25

Maintenance 25, 28,

Maintenance schedules 28

Manuals 6, 9

Notes 4, 5, 22, 28, 31 ~ 35

Nozzle selection 16, 17, 20,

Nozzle adjustment 16, 26, 27

Nufarm 2, 26

Operational pointers 24, 26

Operator training & responsibilities - 18, 22, Safety Manual

Parts lists - Section 8, p.31 ~ 35 or Croplands.com.au

Plumbing system description 14 ~ 16

Pressure gauge 14 ~ 16, 20

Pressure regulator 14 ~ 16, 19, 20

Prestart checks 18, 19, 22

Product identification & specification - Section 3

Pump information 8, 9, 11, 12, 19, 28, 29

Pump running dry 21

Retraspray 13

Safety instructions 4, 6, 21, 22, 24

Safety manual 4, 6

Safety decals 4, 6

Serial number 7, 8

Speed (of spraying) 23, 24, 26, 27

Spray pressure 26, 27

Spray Lance 7, 10 ~ 15, 18, 19, 22, 38

Spray method 23, 24, 26, 27

Sprayer assemblies 30 ~ 35

Sprayer operation 22 ~ 25

Spraying on sloping or uneven ground Safety Manual

Spraywise 26

Storage of sprayer 21, 25, 28

Suction from tank 14, 18,

Table of contents 3

Tank & equipment cleaners 25

Tank draining 7, 15, 17, 25

Tank fill 17, 22, 23

Tank level 11, 12

Tank lids 7, 11, 17

Technical support 30

Troubleshooting pumps 29

Vehicle requirements 6, 14, Safety Manual

Warnings 4, 6, 14, 22, 24, 25,

Warranty 5

Washdown 25, 28

Weather conditions 26

Working environment - Safety Manual

CROPLANDS

AUSTRALIA

Croplands Equipment Pty Ltd
ACN 006 450 184

PO Box 2441
Dry Creek
50 Cavan Road
Dry Creek SA 5094
Australia

Freecall: 1800 999 162
Freefax: 1800 623 778
Email: sales@croplands.com.au
Website: www.croplands.com.au

NEW ZEALAND

Croplands Equipment Ltd
PO Box 2004,
Stortford Bridge, Hastings 4120

Location:
1422 Omaha Road,
Hastings 4120
New Zealand

Freecall: 0800 106 898
Freefax: 0800 117 711
Email: sales@croplands.co.nz
Website: www.croplands.co.nz

Your nearest Croplands Dealer
can be found in the dealer section
on the Croplands website