

HP-319-31

QM-420 SPRAY FAN ASSEMBLY

Using 6.5cc hydraulic motor.

9.8cc hydraulic motor is an option.

NOTE

Drawings are for illustration purposes only - refer to sprayer for actual plumbing. Parts lists are indicative of the sprayer type.

Items in italics or without a part number are non stocked items and may need to be specially ordered.

For further parts information refer to www.croplands.com.au

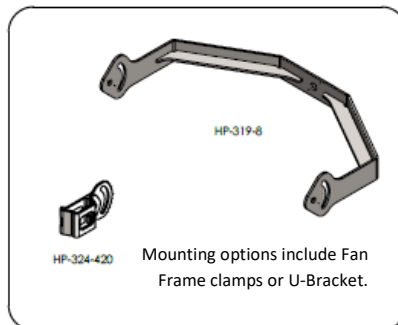
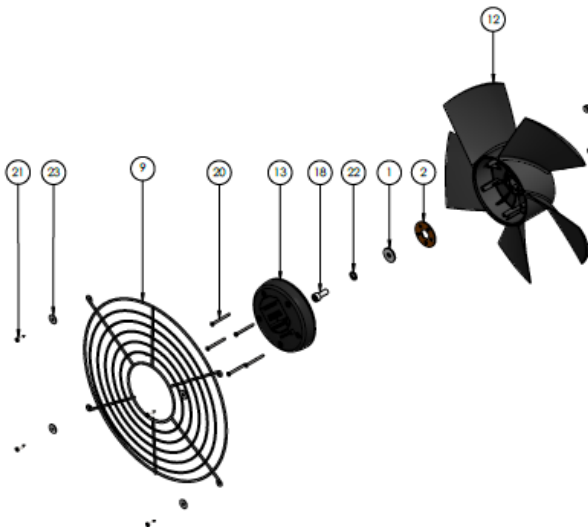
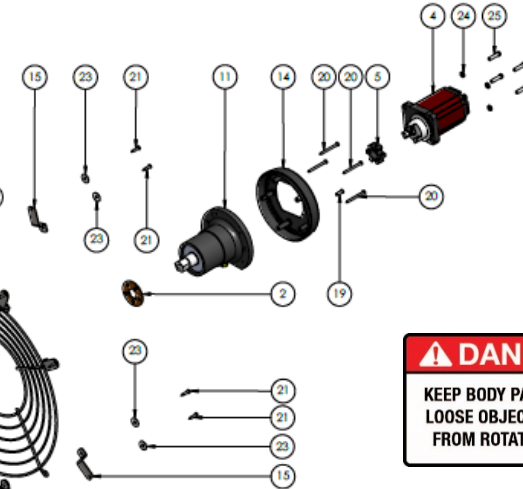
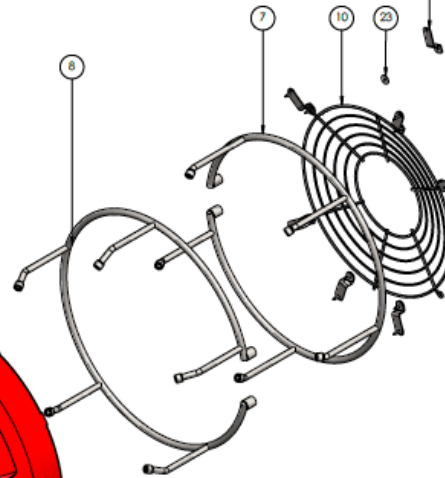

ITEM NO.	PART NUMBER	DESCRIPTION	
1	HP-119-20	WASHER 10X30 STAINLESS STEEL	1
2	HP-119-23	HEP WASHER 5PIN X 2.4	2
3	HP-219-18	WASHER KIDNEY SHAPED S/S	3
4	HP-219M6.5CE-2	HYDRAULIC MOTOR KIT ASSEMBLY 6.5CC	1
5	HP-219-1C	COUPLING INSERT SUIT CH48	1
6	HP-319-3	COWL QM420	1
7	HP-319-5S	SPRAY RING QM420 INNER	1
8	HP-319-5L	SPRAY RING QM420 OUTER	1
9	HP-319-6	GUARD FRONT QM420	1
10	HP-319-7	GUARD REAR QM420	1
11	HP-319-9	MAIN DRIVE BODY ASSEMBLY SERIES 2 HYD	1
12	HP-319-10	FAN PROPELLER QM420	1
13	HP-319-15	COVER FRONT QM420 FAN	1
14	HP-319-15R	COVER REAR QM420 DRIVE BODY	1
15	HP-319-27	CLAMP QM420 GUARD AND RING	8
16	XD-195	LABEL FAN DANGER	1
17	M8X100SBOLT	M8 X 100 S/S BOLT	3
18	M10X25SHSCREW	M10 X 25 ALLEN HEAD SCREW HT ZP	1
19	M5X15SSSCREW	M5 X 15 S/S SCREW	1
20	M4X50SSSCREW	M4 X 50 S/S SCREW	9
21	M4.2X19SSSCREW	M4.2 X 19 S/S SCREW	20
22	M10SWASHER	M10 SPRING WASHER ZP	1
23	M4SSFWASHER	M4 FLAT WASHER S/S	24
24	M6SSFWASHER	M6 SPRING WASHER SS	4
25	M6X25SSSCREW	M6 X 25 HEX HEAD S/S SCREW	4