

**FILTRI A RETE  
SCREEN FILTERS  
FILTROS DE MALLA**



**FILTRI A RETE DA 2" SERIE 333**

- Filetti G 2
- Capacità filtrante 23 m³/h
- Cartuccia Ø 107 x 286 mm
- Corpo in polipropilene, guarnizioni in EPDM
- Pressione d'esercizio max. 8 bar
- Filetto di spurgo G 3/4" (aperto)
- Doppio attacco per manometro G 1/4" F

**2" SCREEN FILTERS SERIES 333**

- 2" BSP threads
- Filtering capacity 23 m³/h
- Cartridge Ø 107 x 286 mm
- Polypropylene body, EPDM gaskets
- Working pressure 8 bar max (116 PSI max)
- Draining thread 3/4" BSP (open)
- Double attachment for 1/4" F BSP pressure gauge

**FILTROS DE MALLA 2" SERIE 333**

- Roscas 2"
- Capacidad filtrante 23 m³/h
- Cartucho Ø 107 x 286 mm
- Cuerpo de polipropilene, juntas de EPDM
- Presión máx. de funcionamiento 8 bar
- Rosca de descarga 3/4" BSP (abierto)
- Doble toma para manómetro 1/4" F BSP



**Struttura cartuccia in polipropilene - Polypropylene cartridge frame - Cartucho de polipropileno**

COD. CODE CÓD.	F (BSP)	Rete Screen Red		Area		Area effettiva Effective area Area efectiva	
		Type	mesh	cm²	sq.inches	cm²	sq.inches
333 2072	G2	Inox	32	531	82.3	294	45.5
333 2073		Inox	50			270	41.8
333 20735		Inox	80			296	45.8
333 2074		Inox	100			246	38.2

**Cartuccia con doppia rete - Double net cartridge Cartucho con doble red**

COD. CODE CÓD.	F (BSP)	Rete Screen Red		Area		Area effettiva Effective area Area efectiva	
		Type	mesh	cm²	sq.inches	cm²	sq.inches
333 22735	G2	Inox	80/32	531	82.3	296	45.8
333 2274		Inox	100/32			246	38.2
333 2275		Inox	120/32			241	37.4
333 2276		Inox	150/32			225	34.9
333 22765		Inox	200/32			192	29.8

**Cartuccia Inox con calza in poliester - Steel frame with polyester sleeve - Cartucho inox. con red de poliéster**

COD. CODE CÓD.	F (BSP)	Rete Screen Red		Area		Area effettiva Effective area Area efectiva	
		Type	mesh	cm²	sq.inches	cm²	sq.inches
333 2175	G2	Polyester	120	740	114.7	318	49.0
333 2176		Polyester	150			259	40.1

**NOTE**

SOME PARTS ARE NON-STOCK ITEMS AND MAY NEED TO BE ORDERED

**NOTE**

PLEASE ADD PREFIX A TO PART NUMBER TO REFLECT CROPLANDS PART NUMBER

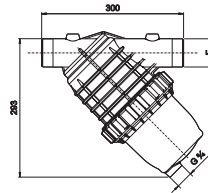
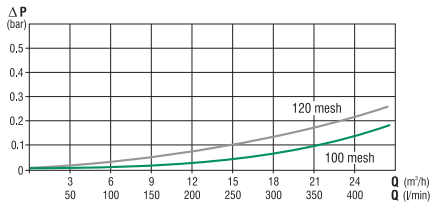

**RICAMBI**

**SPARE PARTS**

**REPUESTOS**

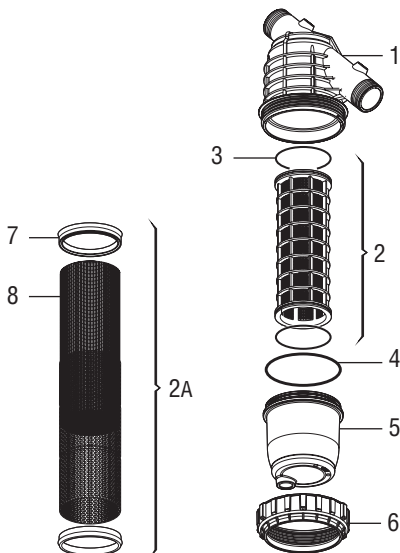

POS.	COD. / CODE / CÓD.	Mesh	Descrizione	Description	Descripción
1	333 2070.010	---	Corpo filtro	Filter body	Cuerpo del filtro
2	317 2002.030	32	Cartuccia filtro	Filter element	Cartucho del filtro
2	317 2003.030	50	Cartuccia filtro	Filter element	Cartucho del filtro
2	317 20035.030	80	Cartuccia filtro	Filter element	Cartucho del filtro
2	317 2004.030	100	Cartuccia filtro	Filter element	Cartucho del filtro
2	317 22035.030	80/32	Cartuccia filtro	Filter element	Cartucho del filtro
2	317 2204.030	100/32	Cartuccia filtro	Filter element	Cartucho del filtro
2	317 2205.030	120/32	Cartuccia filtro	Filter element	Cartucho del filtro
2	317 2206.030	150/32	Cartuccia filtro	Filter element	Cartucho del filtro
2	317 22065.030	200/32	Cartuccia filtro	Filter element	Cartucho del filtro
2A	333 105.030	120	Cartuccia filtro in lamiera	Metal sheet filter element 120 mesh	Cartucho del filtro de chapa
2A	333 106.030	150	Cartuccia filtro in lamiera	Metal sheet filter element 150 mesh	Cartucho del filtro de chapa
3	G11046	---	OR 94.9 x 2.6	OR 94.9 x 2.6	OR 94.9 x 2.6
4	333 000.050	---	OR 144 x 5.3	OR 144 x 5.3	OR 144 x 5.3
5	333 2000.020	---	Coperchio filtro	Filter bowl	Tapa del filtro
6	333 2000.040	---	Ghiera di serraggio	Tightening ring nut	Virola de sujeción
7	333 100.031	---	Guarnizione per cartuccia lamiera	Sheet cartridge seal	Guarnición para cartucho chapa
8	333 105.032	120	Calza in poliester	Polyester sleeve	Trenzado de poliéster
8	333 106.032	150	Calza in poliester	Polyester sleeve	Trenzado de poliéster