



# DirectoValve® 460 Series 2-Way Manifold

The 460BEC ball valve manifold utilizes a compact design that provides reliable performance at a wide range of operating pressures. Available with E or EC series motors with cable or DIN electrical connections. See page 66 for more information on DirectoValve motors.

## Features:

- 22 RPM, 0.7 second shutoff fully open to close.
- With a choice of threaded, QC (Quick Connect) hose barbs or 50 series flange fitting outlet connections, the 460BEC manifold allows quick, simple plumbing for as many valves as needed for your sprayer.
- Stainless steel stem and ball.
- Flow rate: 25 GPM (94 l/min) at 5 PSI (0.34 bar) pressure drop, 35 GPM (132 l/min) at 10 PSI (0.69 bar) pressure drop.
- Maximum pressure rating of 300 PSI (20 bar).
- The 460BEC valve series is also available in 3-way and Flow Back versions. See page 94 for 460B 3C and 3E, 3-way versions and page 96 for 460FB Flow Back version.



**461BEC-2F-C Valve**  
(rear view)

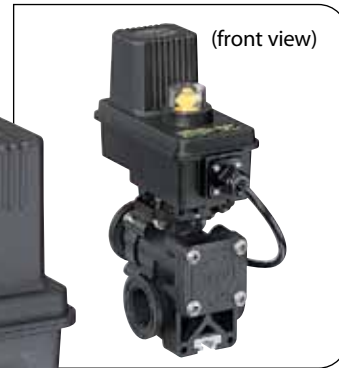

(front view)



**463BEC-2F-C Manifold**  
(rear view)



(front view)



## Sample Valve Part Number:

(B)463BEC-2F-CN15AB

OUTLET THREADS	
PART CODE	DESCRIPTION
BLANK	ALL THREADS TO BE NPT (IF EQUIPPED)
(B)	ALL THREADS TO BE BSPT (IF EQUIPPED)

MODEL SPECIFICATION	
PART CODE	DESCRIPTION
46	460 MANIFOLD

MANIFOLD SIZES	
PART CODE	DESCRIPTION
1	1-VALVE MANIFOLD
2	2-VALVE MANIFOLD
3	3-VALVE MANIFOLD
4	4-VALVE MANIFOLD
5	5-VALVE MANIFOLD

MOTOR SPECIFICATIONS		
PART CODE	SWITCH	DESCRIPTION
E	DPDT	22 RPM, 0.7 SECOND SHUTOFF VALVE
EC	SPST	

See page 66 for more information on E and EC motors.

VALVE TYPE	
PART CODE	DESCRIPTION
2	2-WAY VALVE

See page 94 for 3-way valve.

END CAPS OR OUTLET FITTINGS	
PART CODE	DESCRIPTION
3	3/4" PIPE THREAD
4	1" PIPE THREAD
Q	QUICK CONNECT
F	50 SERIES FLANGE

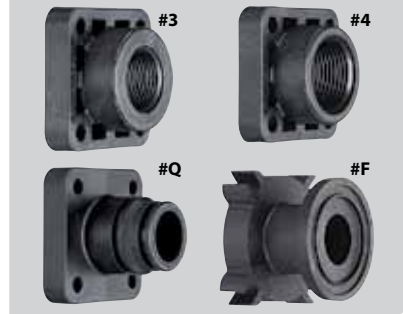

See pages 102–104 for QC and flange fittings.

WIRING CONNECTORS	
SPECIFIC ELECTRICAL CONNECTOR STYLE AND PIN-OUTS. IF NO CONNECTOR IS NEEDED LEAVE BLANK.	
See page 105 for electrical connectors and codes.	

MOTOR CABLES	
PART CODE	DESCRIPTION
C	POSITIVELY SWITCHED w/ 0.5-METER CABLE
CN	NEGATIVELY SWITCHED w/ 0.5-METER CABLE
* C03	POSITIVELY SWITCHED w/ 0.3-METER CABLE
* CN03	NEGATIVELY SWITCHED w/ 0.3-METER CABLE
* C15	POSITIVELY SWITCHED w/ 1.5-METER CABLE
* CN15	NEGATIVELY SWITCHED w/ 1.5-METER CABLE
* C60	POSITIVELY SWITCHED w/ 6.0-METER CABLE
* CN60	NEGATIVELY SWITCHED w/ 6.0-METER CABLE
D	POSITIVELY SWITCHED w/ DIN CONNECTOR
DN	NEGATIVELY SWITCHED w/ DIN CONNECTOR

Items marked with "\*" are non-stock items. Please contact your regional sales office for ordering and availability information.

**Note:** DIN cables must be ordered separately. See page 66 for DIN cables.

### INLET/OUTLET REQUIRED CONNECTIONS THE INLET/OUTLET FITTINGS ARE ORDERED SEPARATELY

- **3, 4:** When ordering 3/4" (3) or 1" (4) NPT or BSPT threaded connections, the valve outlet connection will be completed during the ordering process. For the inlets to be threaded, the 50 series flange fittings are ordered separately. Two 50 series single clamps and fittings are required per manifold assembly. See pages 102–103 for flange fitting options.
- **F:** For the flange fitting versions, one 50 series single clamp and flange fitting is required per valve. For the inlets, two 50 series single clamps and flange fittings are required per manifold assembly. See pages 102–103 for flange fitting options.
- **Q:** When ordering QC (Quick Connect) hose barb type valve fittings. For the outlet, one 45529 QC hose barb connection is required per valve. 460 inlets are 50 series standard flanges. Any two 50 series fittings and clamps may be ordered. For the inlets to be QC, requires two each, CP46029-PP QC flange adapters, 50 series single clamps and 45529 QC hose barb connections per manifold assembly. See page 104 for QC fitting options.

**Note:** Many manifold configurations are possible by mixing and matching flange fittings.

### REPAIR KIT

AB460-KIT

NOTE: MOTOR IS ROTATED  
180° FROM NORMAL  
ORIENTATION TO BETTER  
ILLUSTRATE MOTOR DETAIL.

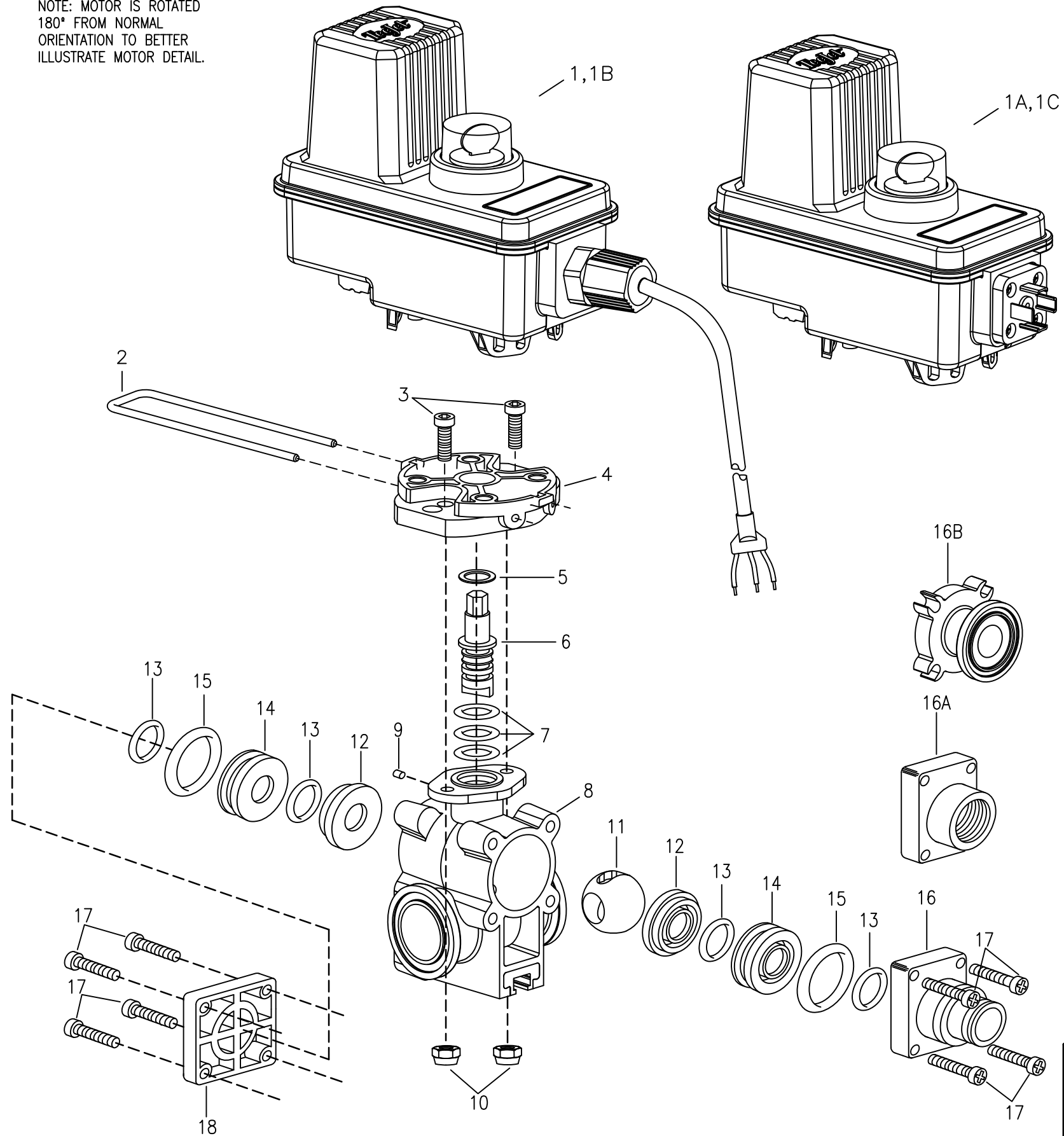

ITEM	SALES PART NO.	DESCRIPTION	
1	50515-22CP03 ■	BEC MOTOR, 22-RPM (0.7-SEC), 0.3-METER CABLE, POSITIVELY SWITCHED	
	50515-22CP05 ■	BEC MOTOR, 22-RPM (0.7-SEC), 0.5-METER CABLE, POSITIVELY SWITCHED	
	50515-22CP15 ■	BEC MOTOR, 22-RPM (0.7-SEC), 1.5-METER CABLE, POSITIVELY SWITCHED	
	50515-22CP60 ■	BEC MOTOR, 22-RPM (0.7-SEC), 6.0-METER CABLE, POSITIVELY SWITCHED	
1A	50515-22DP ■	BEC MOTOR, 22-RPM (0.7-SEC), DIN CONNECTION, POSITIVELY SWITCHED	
1B	50533-22C03	BE MOTOR, 22-RPM (0.7-SEC), 0.3-METER CABLE	
	50533-22C05	BE MOTOR, 22-RPM (0.7-SEC), 0.5-METER CABLE	
	50533-22C15	BE MOTOR, 22-RPM (0.7-SEC), 1.5-METER CABLE	
	50533-22C60	BE MOTOR, 22-RPM (0.7-SEC), 6.0-METER CABLE	
1C	50533-22D	BE MOTOR, 22-RPM (0.7-SEC), DIN CONNECTION	
2	CP50517-SSPV	RETAINING CLIP, 304 STAINLESS STEEL	
3	CP26197-7/8-SS	SOCKET HEAD CAP SCREW, STAINLESS STEEL (2 REQ'D)	
4	CP50514-PP	MOTOR ADAPTER, POLYPROPYLENE (BLACK)	
*	5	CP20125-TEF	THRUST WASHER, TEFLON
6	CP56614-SS	STEM, 303 STAINLESS STEEL	
*	7	CP7717-M12X2.5-VI	O-RING, VITON (3 REQ'D)
8	CP45503-NYB	BODY, NYLON (INCLUDES MOUNTING RAIL)	
*	9	CP20126-FELT	DUST PLUG, FELT
10	CP38435-1/4-SSNY	ELASTIC LOCKNUT, STAINLESS STEEL (2 REQ'D)	
11	CP45510-1-SS	BALL, 303 STAINLESS STEEL	
*	12	CP20103-TEF	SEAL, TEFLON (2 REQ'D)
*	13	CP7717-2-213-VI	O-RING, VITON (4 REQ'D)
14	CP45502-NYB	BALL SEAL SPACER, NYLON (BLACK) (2 REQ'D)	
*	15	CP7717-2-322-VI	O-RING, VITON (2 REQ'D)
16	CP45514-NYB	ENDCAP, NYLON (BLACK) (QUICK CONNECT)	
16A	CP20104-3/4-NYB	ENDCAP, NYLON (BLACK) (3/4" NPT THREAD)	
	CPB20104-3/4-NYB	ENDCAP, NYLON (BLACK) (3/4" BSPT THREAD)	
	CP20104-1-NYB	ENDCAP, NYLON (BLACK) (1" NPT THREAD)	
	CPB20104-1-NYB	ENDCAP, NYLON (BLACK) (1" BSPT THREAD)	
16B	CP45253-NYB	ENDCAP, NYLON (BLACK) (50-SERIES FLANGED)	
17	CP45517-1-1/8-SS	PAN HEAD SCREW, STAINLESS STEEL (8 REQ'D)	
18	CP45518-NYB	REAR COVER, NYLON (BLACK)	
	56611-2-_-_-	VALVE BODY SUB-ASS'Y, SPECIFY OUTLET SIZE & BALL MATERIAL (3-19)	

AB460B-KIT, SPARE PARTS KIT (INCLUDES ALL ITEMS MARKED WITH \*)

NOTE: (B) IN PART NUMBER INDICATES B.S.P.T INLET AND OUTLET CONNECTIONS  
 ■ NOTE: FOR NEGATIVELY SWITCHED MOTORS SPECIFY "N" RATHER THAN "P" IN MOTOR PART NUMBER. EXAMPLE: 50515-22CN05

TEFLON® IS A TRADEMARK OF DUPONT COMPANY  
 VITON® IS A TRADEMARK OF DUPONT DOW ELASTOMERS

**DESCRIPTION:**  
 460BEC 2-WAY  
 DIRECTOVALVE®  
 ELECTRIC SHUT-OFF  
 BALL VALVE MANIFOLD



**Spraying Systems Co.®**

Spray Nozzles and Accessories  
 P.O. Box 7900 - Wheaton, IL 60189-7900

Rev. No. 2

Ref.

PARTS LIST  
 PL460BEC  
 SHEET OF