

BA70LOOM/GS2A ADAPTOR LOOM
TRACTOR/MODULE END

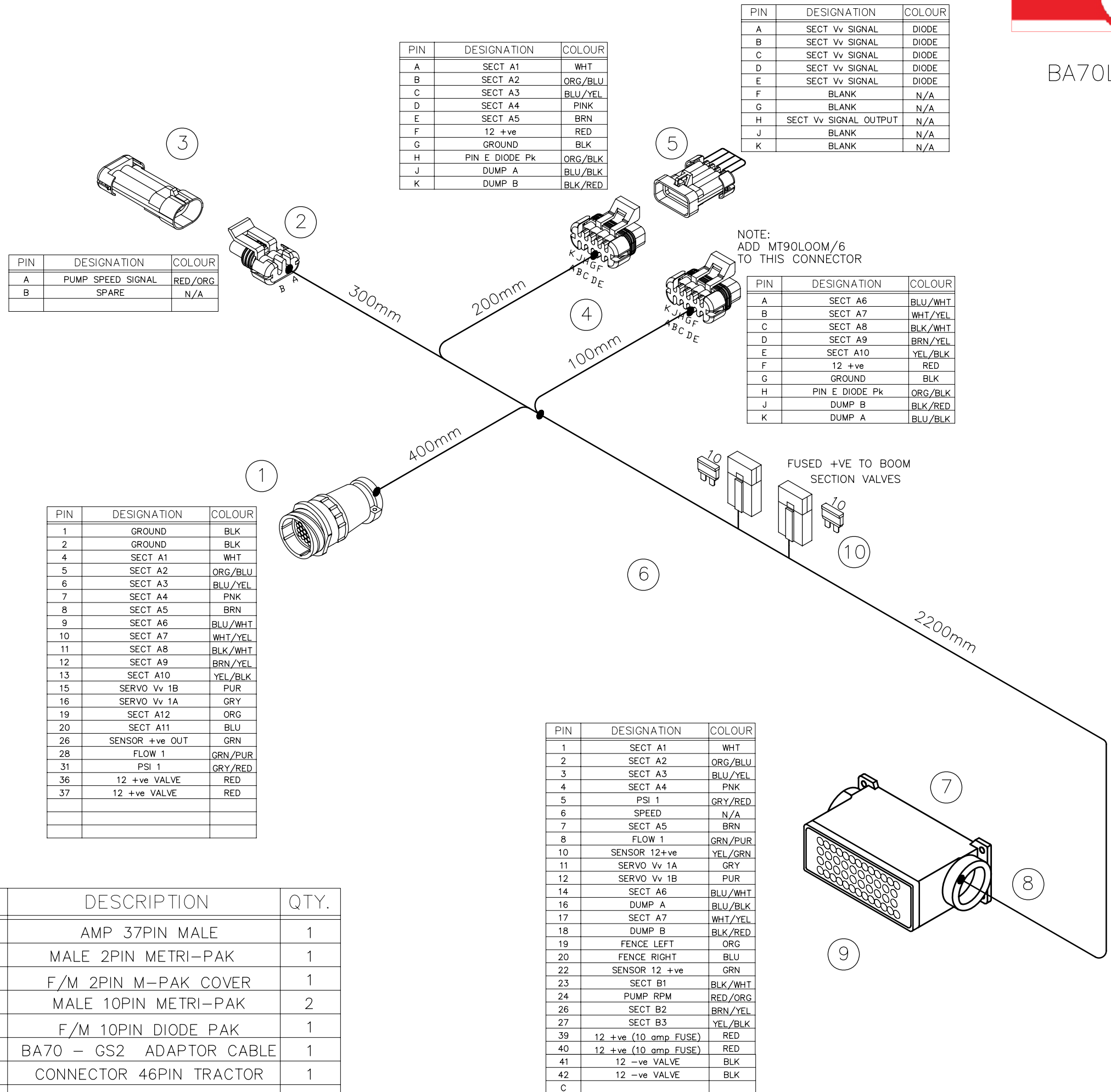

PIN	DESIGNATION	COLOUR
A	SECT A1	WHT
B	SECT A2	ORG/BLU
C	SECT A3	BLU/YEL
D	SECT A4	PNK
E	SECT A5	BRN
F	12 +ve	RED
G	GROUND	BLK
H	PIN E DIODE Pk	ORG/BLK
J	DUMP A	BLU/BLK
K	DUMP B	BLK/RED

PIN	DESIGNATION	COLOUR
A	SECT Vv SIGNAL	DIODE
B	SECT Vv SIGNAL	DIODE
C	SECT Vv SIGNAL	DIODE
D	SECT Vv SIGNAL	DIODE
E	SECT Vv SIGNAL	DIODE
F	BLANK	N/A
G	BLANK	N/A
H	SECT Vv SIGNAL OUTPUT	N/A
J	BLANK	N/A
K	BLANK	N/A

PIN	DESIGNATION	COLOUR
A	PUMP SPEED SIGNAL	RED/ORG
B	SPARE	N/A

PIN	DESIGNATION	COLOUR
A	SECT A6	BLU/WHT
B	SECT A7	WHT/YEL
C	SECT A8	BLK/WHT
D	SECT A9	BRN/YEL
E	SECT A10	YEL/BLK
F	12 +ve	RED
G	GROUND	BLK
H	PIN E DIODE Pk	ORG/BLK
J	DUMP B	BLK/RED
K	DUMP A	BLU/BLK

PIN	DESIGNATION	COLOUR
1	GROUND	BLK
2	GROUND	BLK
4	SECT A1	WHT
5	SECT A2	ORG/BLU
6	SECT A3	BLU/YEL
7	SECT A4	PNK
8	SECT A5	BRN
9	SECT A6	BLU/WHT
10	SECT A7	WHT/YEL
11	SECT A8	BLK/WHT
12	SECT A9	BRN/YEL
13	SECT A10	YEL/BLK
15	SERVO Vv 1B	PUR
16	SERVO Vv 1A	GRY
19	SECT A12	ORG
20	SECT A11	BLU
26	SENSOR +ve OUT	GRN
28	FLOW 1	GRN/PUR
31	PSI 1	GRY/RED
36	12 +ve VALVE	RED
37	12 +ve VALVE	RED

PIN	DESIGNATION	COLOUR
1	SECT A1	WHT
2	SECT A2	ORG/BLU
3	SECT A3	BLU/YEL
4	SECT A4	PNK
5	PSI 1	GRY/RED
6	SPEED	N/A
7	SECT A5	BRN
8	FLOW 1	GRN/PUR
10	SENSOR 12+ve	YEL/GRN
11	SERVO Vv 1A	GRY
12	SERVO Vv 1B	PUR
14	SECT A6	BLU/WHT
16	DUMP A	BLU/BLK
17	SECT A7	WHT/YEL
18	DUMP B	BLK/RED
19	FENCE LEFT	ORG
20	FENCE RIGHT	BLU
22	SENSOR 12 +ve	GRN
23	SECT B1	BLK/WHT
24	PUMP RPM	RED/ORG
26	SECT B2	BRN/YEL
27	SECT B3	YEL/BLK
39	12 +ve (10 amp FUSE)	RED
40	12 +ve (10 amp FUSE)	RED
41	12 -ve VALVE	BLK
42	12 -ve VALVE	BLK

ITEM	PART NUMBER	DESCRIPTION	QTY.
1		AMP 37PIN MALE	1
2		MALE 2PIN METRI-PAK	1
3		F/M 2PIN M-PAK COVER	1
4		MALE 10PIN METRI-PAK	2
5		F/M 10PIN DIODE PAK	1
6	BA70LOOM/GS2	BA70 - GS2 ADAPTOR CABLE	1
7	HEE-046-F	CONNECTOR 46PIN TRACTOR	1
8	PG29	CABLE GLAND PLASTIC	1
9	RS452316	DUST COVER (NOT SHOWN)	1
10		10 AMP BLADE FUSE	2

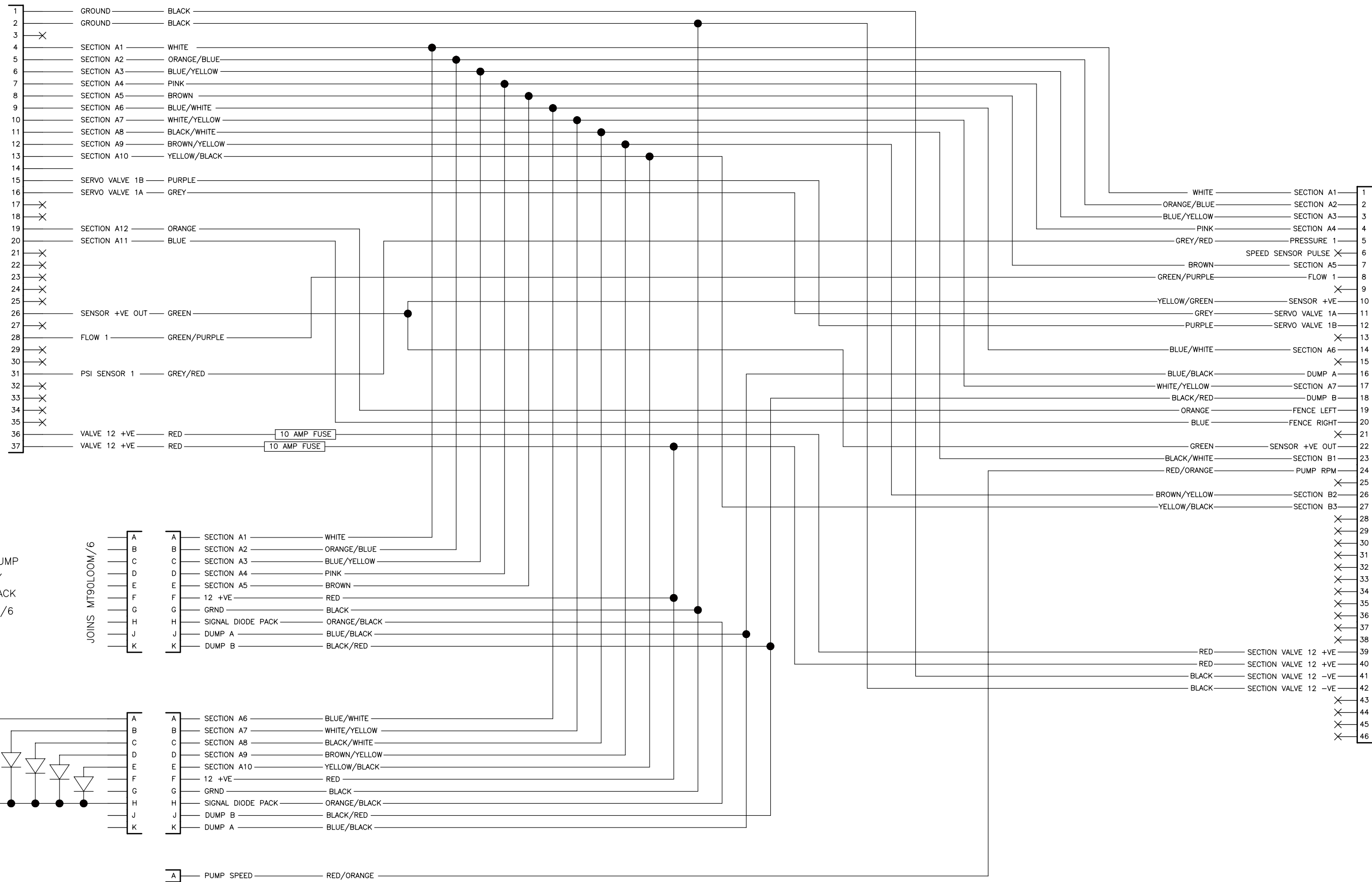

NOTE:
TO REVERSE DUMP
VALVE POLARITY
SWAP DIODE PACK
AND MT90LOOM/6

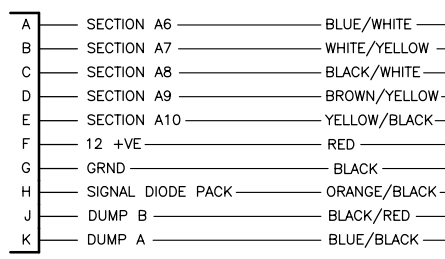
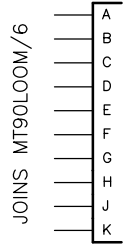

BA70LOOM/GS2A ADAPTOR LOOM
TRACTOR/MODULE END



21st SEPTEMBER 2011

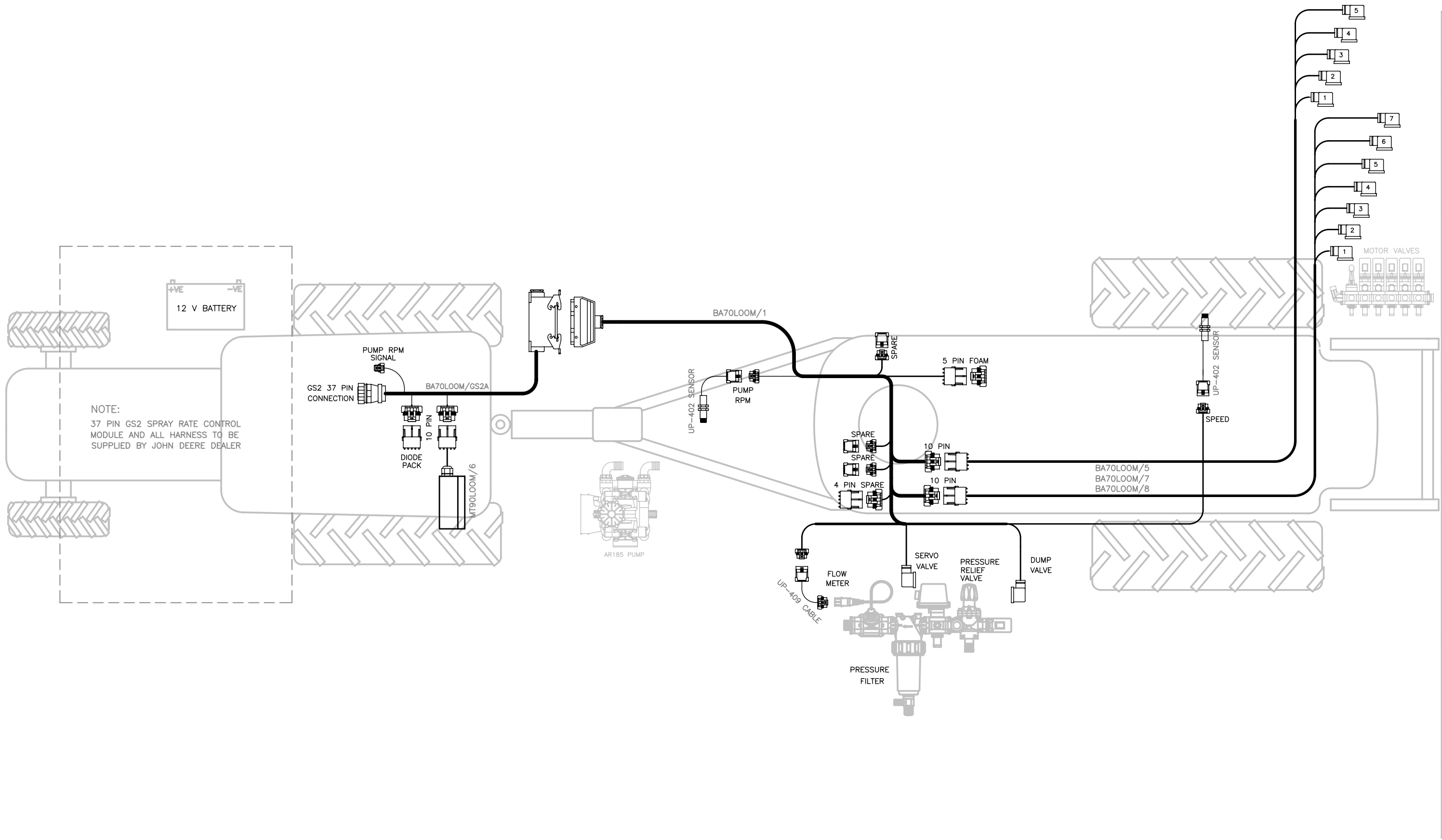

GS2 ADAPTOR
BA70 SERIES LOOM OVERVIEW

