

Item	Part No.	Description	Qty
1	BP-545B	STUB AXLE 80MM 8/275 PCD	2
2	BP-650-12	AXLE BEAM	1
3	MT10013	SPEED SENSOR MOUNTING BRACKET	1

Note: Drawing is for illustration purpose only
Refer to parts list.

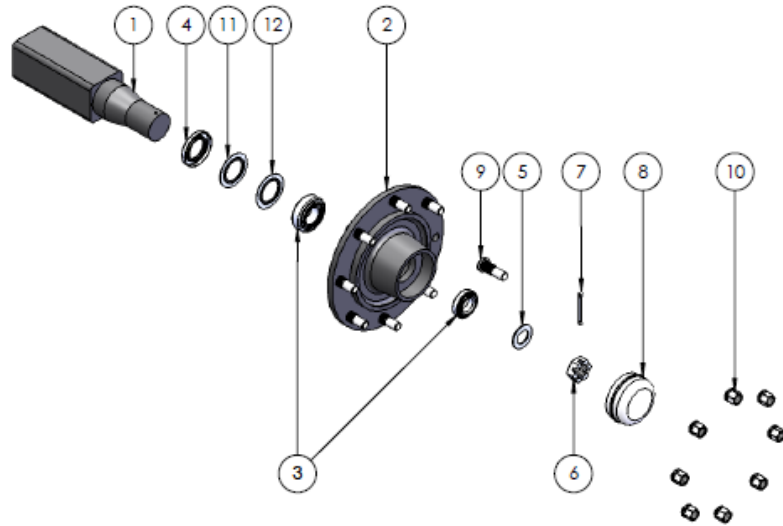

STUB AXLE BP-545B

Item	Croplands P/N	Description
1	BP-545B-1	STUB 80SQx505LG
2	BP-545B-2	WHEELHUB 8/275PCD
3	BP-545B-3	BEARING KIT 30210/30214
4	HP-199E-4	TRIPLE LIP SEAL 125x90x12mm
5	<i>N/A</i>	<i>N/A</i>
6	HP-199E-9	SLOTTED/CASTLE NUT M39x2
7	BP-532-7	SPLIT PIN 80 X 8MM
8	HP-199E-6	DUST CAP (3 screws items 13 and 14)
9	HP-199F-7	WHEEL STUD M18 X 1.5x 65
10	HP-199F-8	WHEEL NUT M18x1.5
11	BP-545B-11	SEAL RING 70.5x90x16.5mm
12	HP-199E-4B	WEAR RING (to suit triple lip seal)
13	HP-199E-11	SOCKET HEAD CAP SCREW M8x30 (<i>not shown</i>)
14	HP-199E-12	M8 RIB LOCK WASHER (<i>not shown</i>)

Note: Parts in italics are non-stock items and may need to be ordered