

| ITEM NO. | PART NUMBER | Description | QTY. |
|----------|----------------|------------------------------------|------|
| 1 | BP-700C-16-001 | GREASE NIPPLE 1/8 BSP 45 DEG | 1 |
| 2 | BP-700C-16-004 | SEAL 80 X 55 X 10 | 2 |
| 3 | BP-700C-16-005 | TAPERED ROLLER BEARING 40X80X19.75 | 2 |
| 4 | BP-700C-16-006 | WASHER LOCK TAB | 1 |
| 5 | BP-700C-16-007 | LOCK NUT | 1 |
| 6 | BP-700C-16-008 | SEAL NUT | 1 |
| 7 | BP-700C-16-009 | STUB AXLE | 1 |
| 8 | BP-700C-16-010 | 5 X 140 HUB | 1 |
| 9 | FSP43 | WHEEL STUD M16X1.5X50 | 5 |
| 10 | MP-392 | WHEEL NUT M16 X 1.5 | 5 |

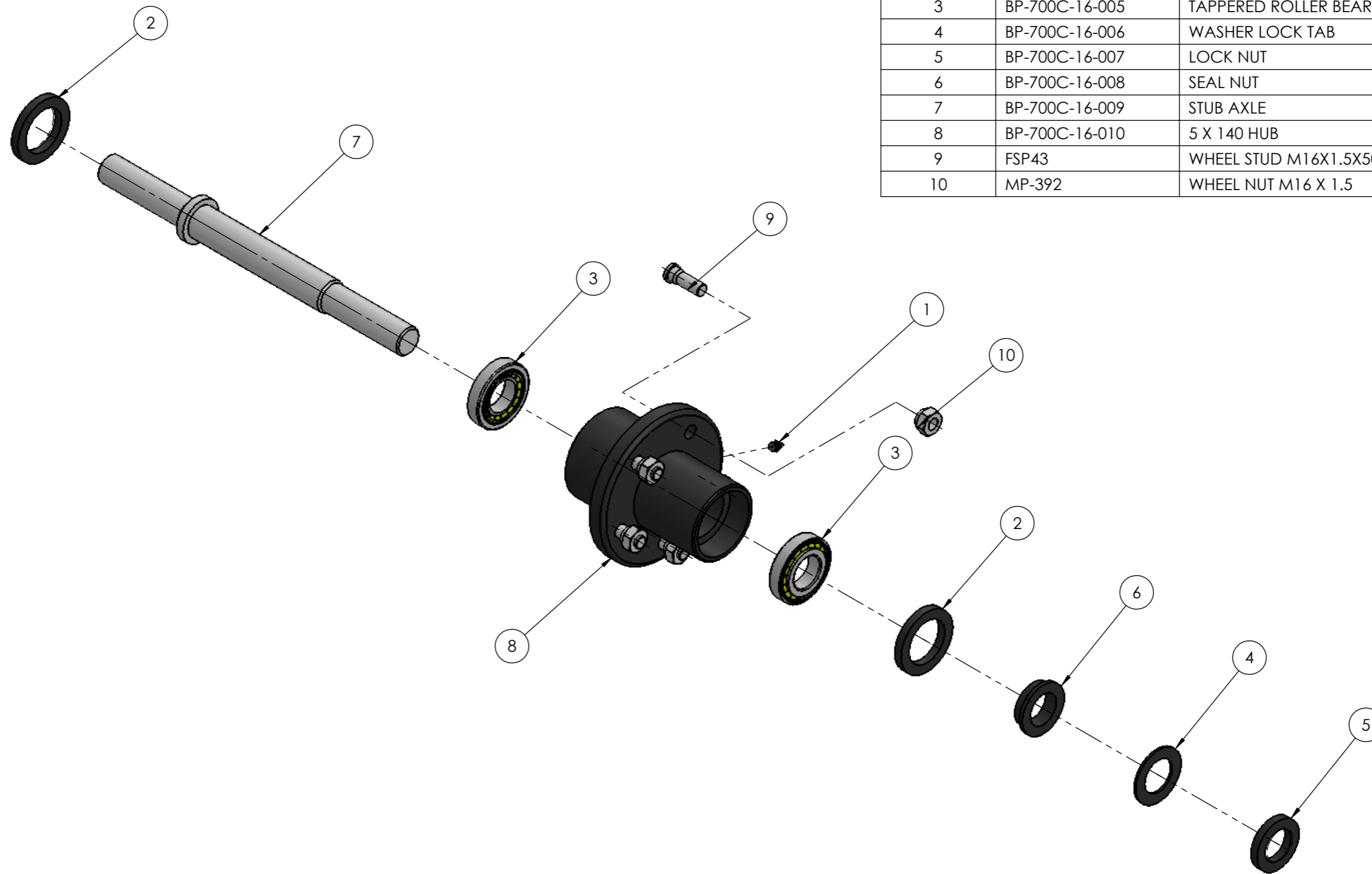

| UNLESS OTHERWISE SPECIFIED: DIMENSIONS ARE IN MILLIMETERS SURFACE FINISH: ± 0.2 TOLERANCES: LINEAR: ± 0.5 ANGULAR: ± 0.5 | | FINISH: N/A | DEBUR AND BREAK SHARP EDGES | DO NOT SCALE DRAWING | ISSUE | A | | | | | | | | | | | | | | | | | | | | | | | |
|---|-----------|--------------------|---------------------------------------|----------------------|--------------|----------|-------|---------|--------|--|-------|--|--|--|--------|--|--|--|-----|--|--|--|-----|--|--|--|--|--|--|
| <table border="1"> <thead> <tr> <th>NAME</th> <th>SIGNATURE</th> <th>DATE</th> <th>REVISION</th> </tr> </thead> <tbody> <tr> <td>DRAWN</td> <td>LJSMITH</td> <td>080116</td> <td></td> </tr> <tr> <td>CHK'D</td> <td></td> <td></td> <td></td> </tr> <tr> <td>APPV'D</td> <td></td> <td></td> <td></td> </tr> <tr> <td>MFG</td> <td></td> <td></td> <td></td> </tr> <tr> <td>Q.A</td> <td></td> <td></td> <td></td> </tr> </tbody> </table> | | | NAME | SIGNATURE | DATE | REVISION | DRAWN | LJSMITH | 080116 | | CHK'D | | | | APPV'D | | | | MFG | | | | Q.A | | | | <p>CROPLANDS A NUFARM LIMITED COMPANY</p> <p>TITLE: WEEDIT SERIES 3 R&D</p> <p>AXLE AND HUB FOR WEEDIT STEERING AND CASTOR WHEEL</p> | | |
| NAME | SIGNATURE | DATE | REVISION | | | | | | | | | | | | | | | | | | | | | | | | | | |
| DRAWN | LJSMITH | 080116 | | | | | | | | | | | | | | | | | | | | | | | | | | | |
| CHK'D | | | | | | | | | | | | | | | | | | | | | | | | | | | | | |
| APPV'D | | | | | | | | | | | | | | | | | | | | | | | | | | | | | |
| MFG | | | | | | | | | | | | | | | | | | | | | | | | | | | | | |
| Q.A | | | | | | | | | | | | | | | | | | | | | | | | | | | | | |
| <small>COPYRIGHT PROPRIETOR THIS DRAWING IS THE PROPERTY OF CROPLANDS PTY. LTD. AND MUST BE TREATED AS CONFIDENTIAL. REPRODUCTION OF THIS DRAWING (OR PART THEREOF) OR COMMUNICATION OF ITS CONTENTS IS PROHIBITED WITHOUT THE CONSENT OF CROPLANDS PTY. LTD.</small> | | | MATERIAL: N/A | DWG NO. | BP-700C-16 | A3 | | | | | | | | | | | | | | | | | | | | | | | |
| | | | WEIGHT: | SCALE: 1:5 | SHEET 1 OF 1 | | | | | | | | | | | | | | | | | | | | | | | | |