

CBLOOM/RV50 ADAPTOR LOOM
NODE TO SPRAYER LOOM

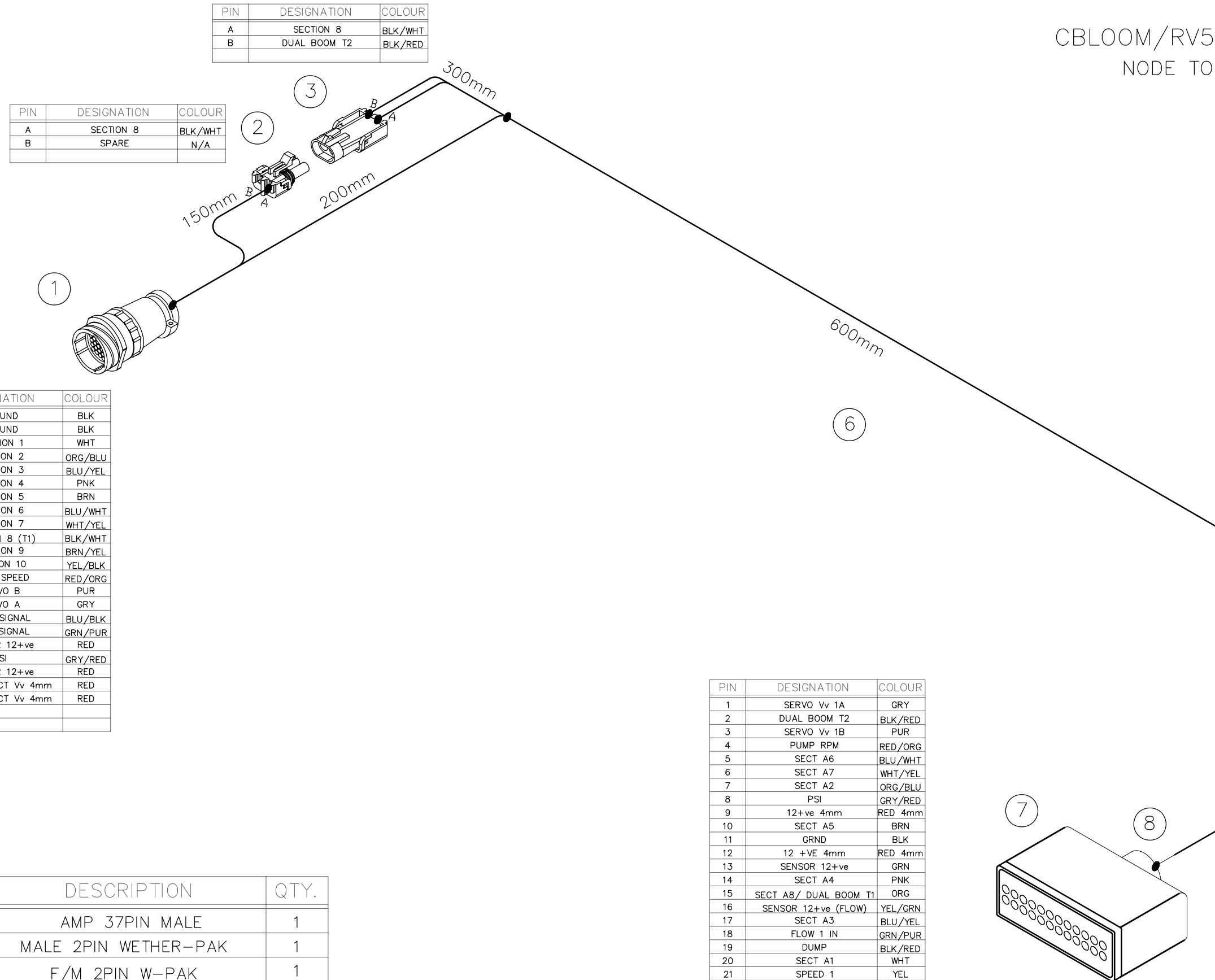

NOTE:
DIMENSION REF

ITEM	PART NUMBER	DESCRIPTION	QTY.
1		AMP 37PIN MALE	1
2		MALE 2PIN WETHER-PAK	1
3		F/M 2PIN W-PAK	1
4			
5			
6	CBLOOM/RV50	SCS5000 - CBLOOM ADAPTOR	1
7	HEE-024-M	CONNECTOR 24PIN SPRAYER	1
8	PG21	CABLE GLAND PLASTIC	1

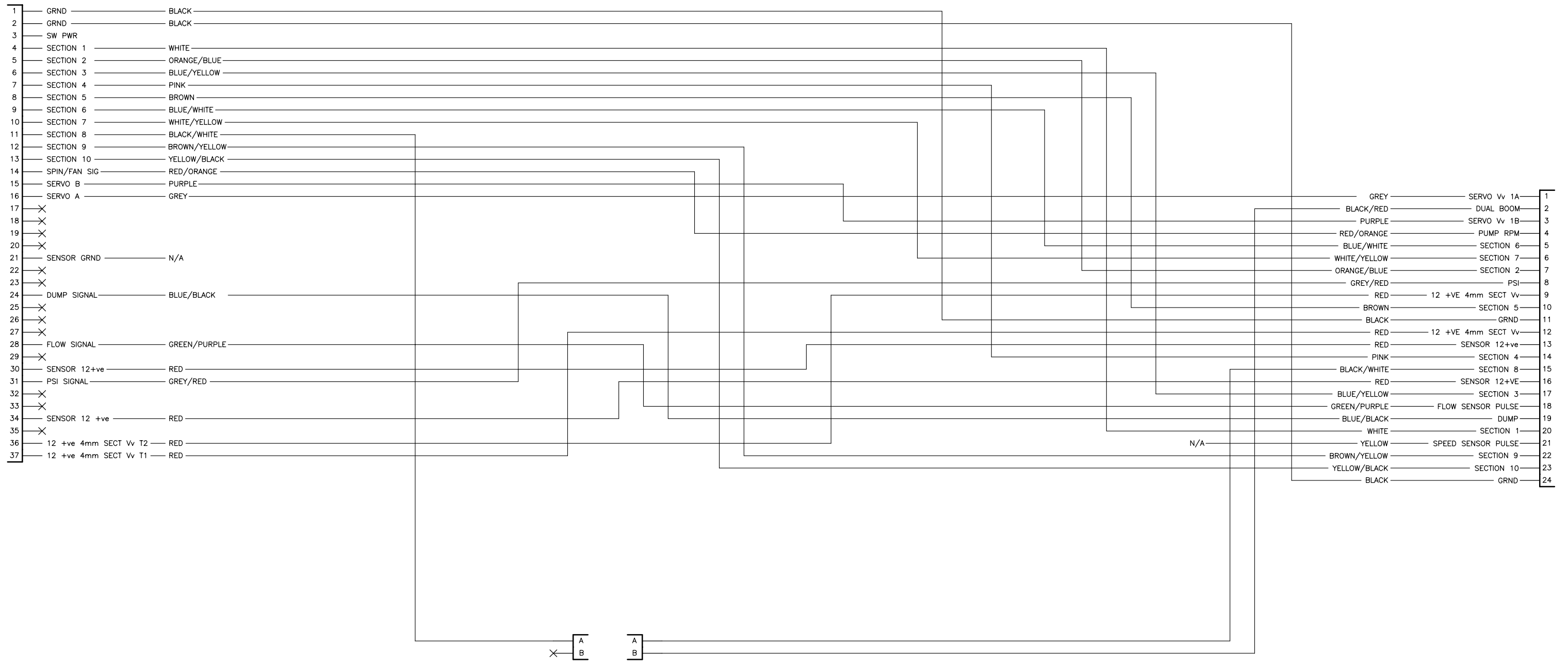

NOTES:

- SERVO VALVE WIRES MAY NEED TO BE REVERSED AT PINS 1 & 3 IN 24 PIN CONNECTOR ON CBLOOM/RV50 TO CONFIRM CORRECT SERVO VALVE OPERATION

CBLOOM/RV50
RAVEN 5000 CONTROL
ADAPTOR LOOM

14th FEBRUARY 2011



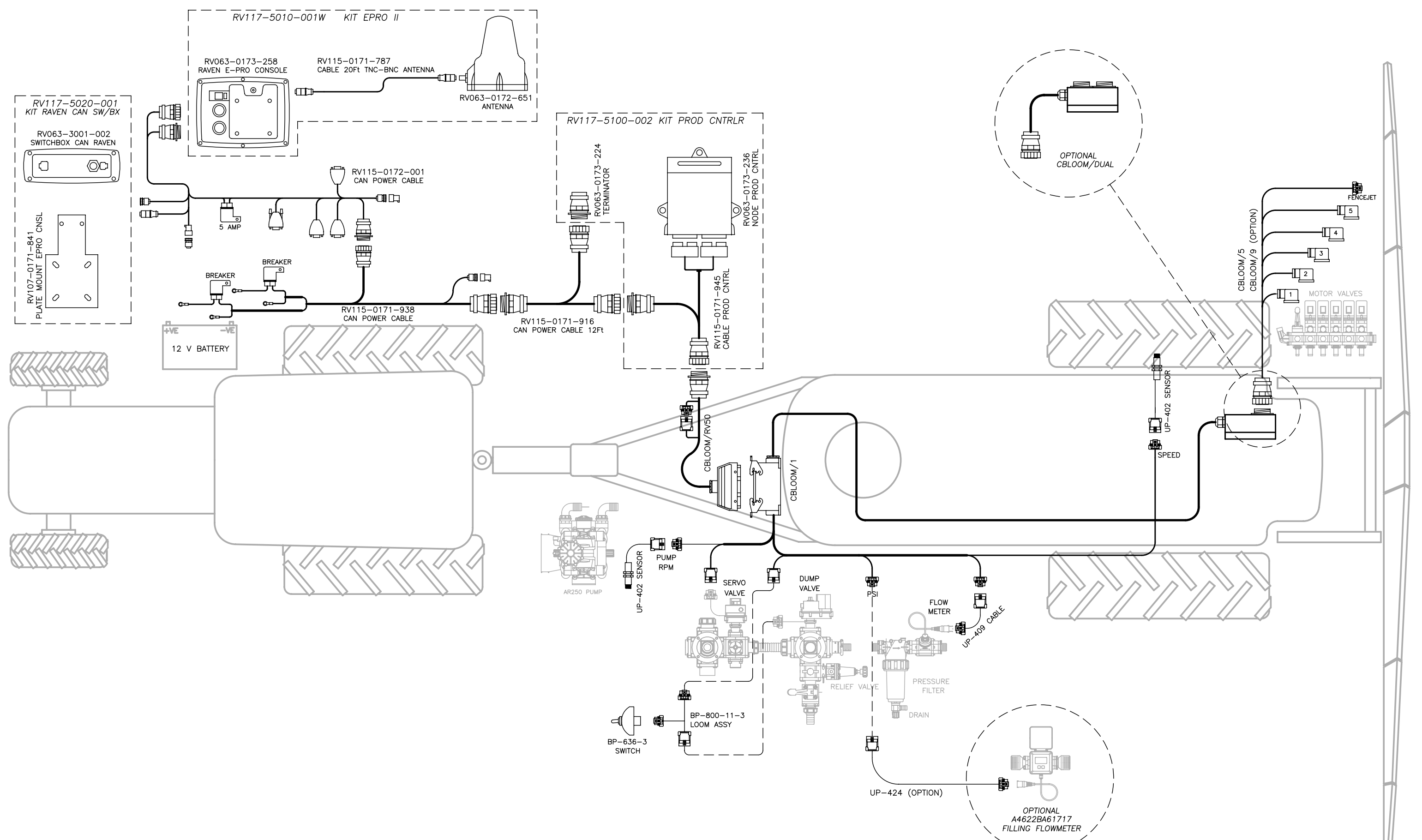

RAVEN E-PRO
 AUTO SECTION CONTROL
 CB SERIES LOOM OVERVIEW

Note: Drawing is for illustration purpose only 6th OCTOBER 2011

