

#9A 'BC "	D5FHBI A 69F	8 9G7 F-ĐHC B	E HM
%	5 %\$\$\$)	B@H: C F?	%
&	5 %- % &)	<C G9H5 @H A '8"&)	(
'	5 %%- % &)	9@C K 'H) A '8"&)	%
(	5 &% &) \$	5 85DH9F 'DF9GG F9; 51; 9H):	%
)	5, *' H5\$%	9@97 HF 7 'J 5@ 9, *' H7 5B6I G	(
*	5; %0(\$), J	C 'F-B; 'J #C B	(
+	5; %0\$*'	C 'F-B; '9D8A	%
,	6>>6\$&) \$', !- \$	9@C K %#( "BDHL" #, "65F6	%

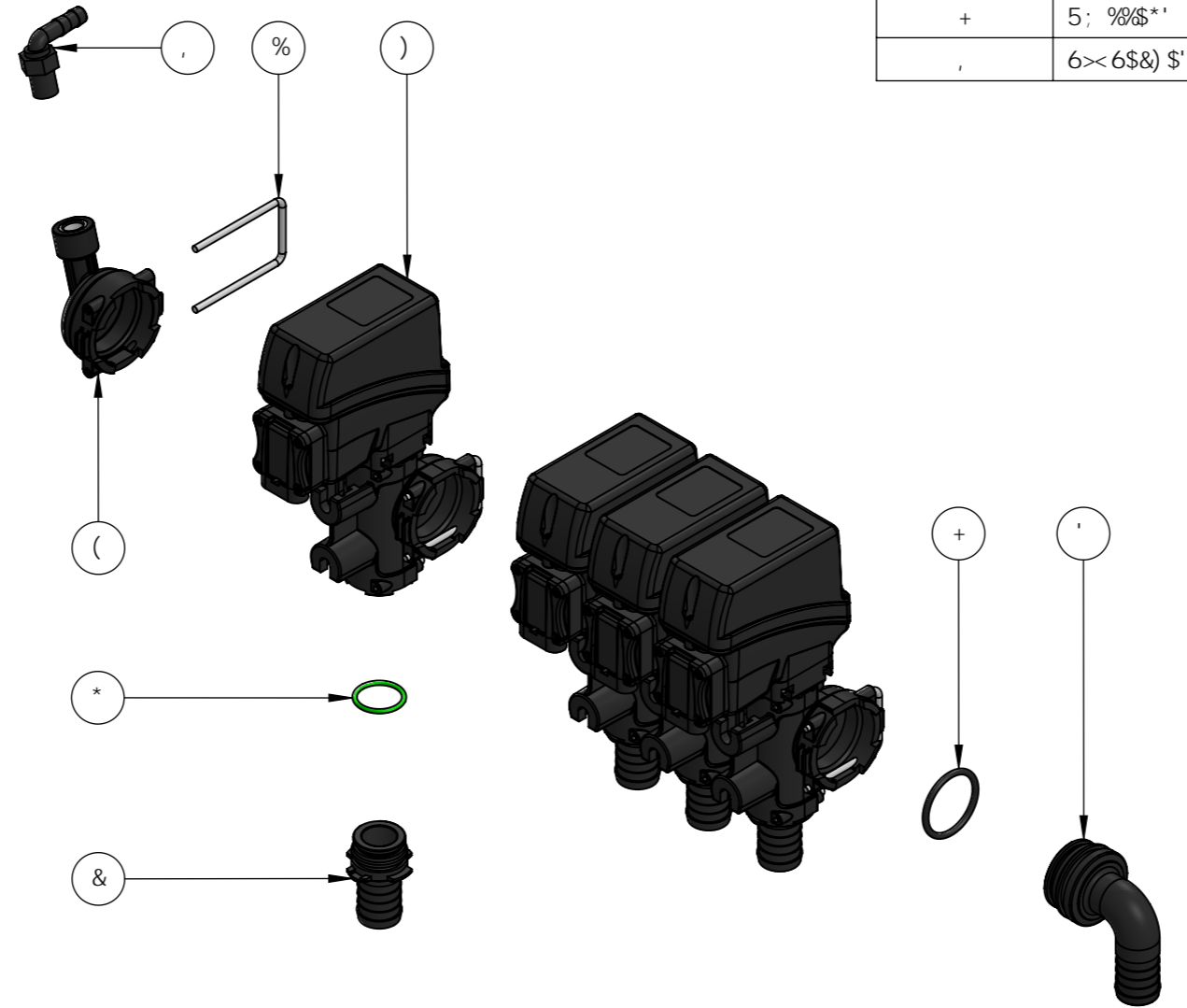

?<!) %%%D5FHG' @ GF5HC B  
 H<8F5K B; 'G: C F' @ GF5HC B 'DI FDC G9' C B @M  
 D@95G9F9: 9F 'HC 'H: 9D5FHG @G'

I B@GGC H: 9FK G9 GD97 ± 98. 8 A 9BGC BG5F9 B A @A 9HFG G F: 57 9: B G<... ± S' & HC @9F5B7 9G..... .....@B95F..... ± S') .....5B: I @5F..... ± S')		: B G<.		B #5		8 96I F 5B8' 6F 95? G<5FD 98: 9G		8C B<HG7 5@8F5K B: 83 9		5	
B5A 9		G: B5H F9		85H9		F9J GCB		H#9:		<b>7FC D@B8G</b> 5 BI : 5FA 'A #98 7CA D5BM	
8F5K B		FD>I 7C		\$90\$%						<b>E I 5BH A 'A -GHCA 5FHGD5MF</b>	
7 <?B										A 5B ÷ C @B 'H) ( 'B9: 'G97 HC BG	
5DDJ B											
A ::											
E *5						A 5H9F 5@		8K : BC*		?<!) %%%	
7 CDMF ± <HDFC DF 4CF						B #5				5'	
H: 6BF5K B; 'G: 9DFC D9HMC: 7 FCDI5B8GDM#B* 5B8 A I Q169H 95H8 5G7CB: @98H@ F@9C B I H@B C: H 6BF5K B; 'G: 9DFC D9HMC: LCF 7CA I B 75HC B C: 4G7CBH8HG DFC < 6H8 K H: C I H: 97CB8HMC: 7 FCDI5B8GDM#B*						K 9: <H'		G7 5@9: % (		G<99H% C: %	