

#9A 'BC "	D5FHBI A 69F	8 9G7 F-ĐHC B	E HM
%	5 %\$\$\$)	B@H: CF?	%
&	5 %\$- % &)	<C G9H5 @H A '8"&)	,
'	5 %%- % &)	9@C K 'H) A '8"&)	%
(5 &% &) \$	5 85DH9F 'DF9GGI F9; 5I ; 9H):	%
)	5, *' H5 \$%	9@97 HF-7 'J 5@ 9, *' H7 5B6I G	,
*	5; %0(\$), J	C 'F-B; 'J #C B	,
+	5; %0(\$*'	C 'F-B; '9D8A	%
,	6><6\$&) '\$, !- \$	9@C K %#("BDHL" #, "65F6	%

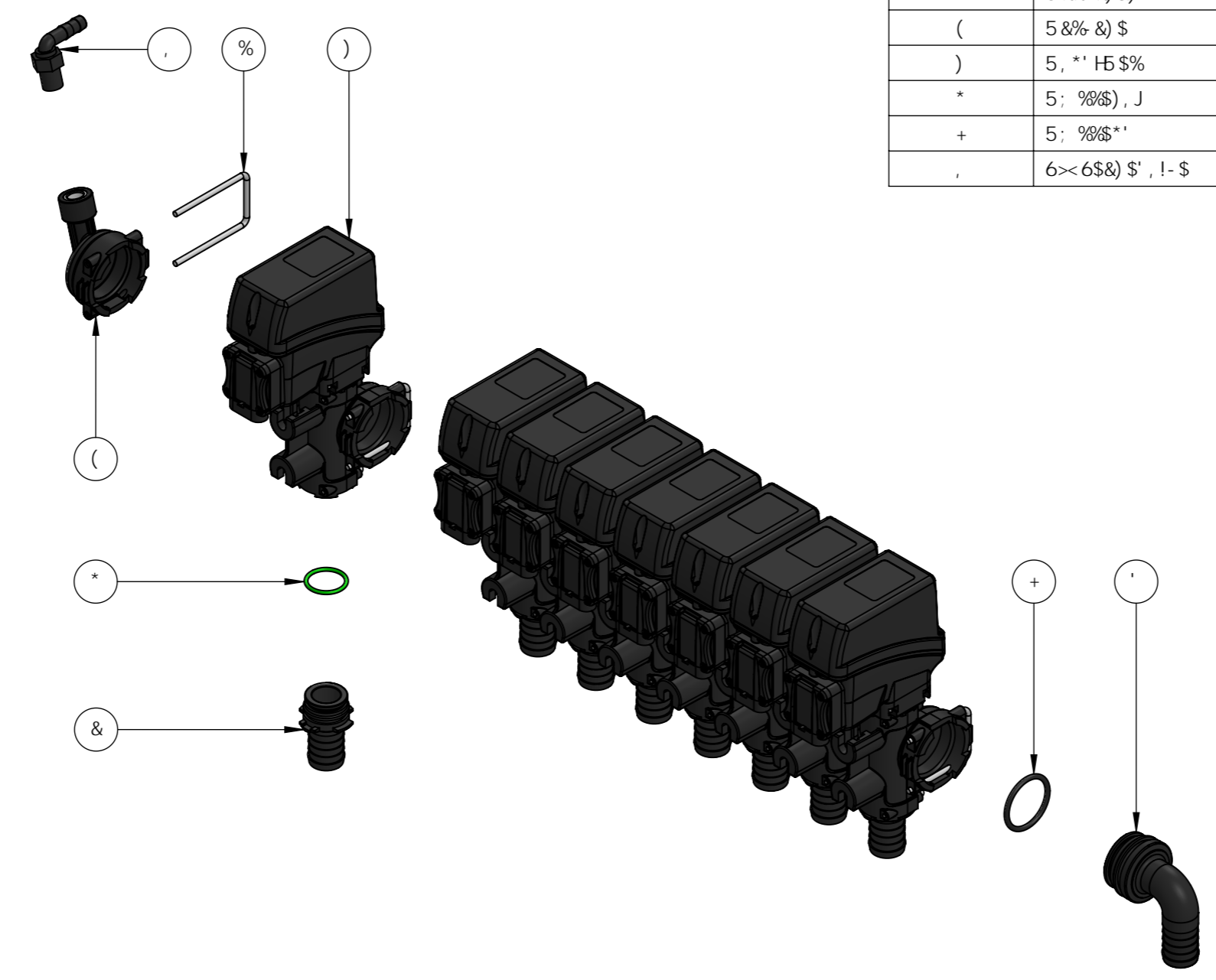

?<!) %&'D5FHG' @ GF5HC B
 H-68F5K B; 'G: C F' @ GF5HC B 'DI FDC G9' C B @M
 D@95G9F9: 9F 'HC 'H:9D5FHG@G'

I B@GGC H:9FK G9GD97 @98. 8 A 9BGC BG5F9 B A @9A 9HFG G F: 57 9: B G<... ± S' & HC @9F5B7 9G @B95F... ± S' 5B; I @5F... ± S')		: B G<.		B #5		8 96I F 5B8' 6F 95? G<5FD 98: 9G		8C BC HG7 5@98F5K B;		€3 9		5	
8F5K B		FD>I 7C		G@ B5H F9		85H@		F9J GCB		H#9.		7FC D@5B8G 5 BI : 5FA @A #98 7CA D5BM	
7 <?B												E I 5BH A 'A -GHCA 5FHGD5MF	
5DDJ B												A 5B ÷ C @8 'H) ; 'B9: 'G97 HC BG	
A ::													
E *5								A 5H@F-5@		8K : BC*		?<!) %&	
7CDMF @<HDFC DF@CF								B #5				5'	
H: 68F5K B; 'G: 9DFC D9HMC: 7FCDI5B8GDM@B*													
5B8 A I G69H 95H@ 5G7CB: @98H@													
F@9C B I H@B C: H: 68F5K B; 'G: 9DFC D9HMC: LCF7CA I B75HC B C:													
H: 68F5K B; 'G: 9DFC D9HMC: 7FCDI5B8GDM@B*								K 9@ <H'		G7 5@9: %(<		G<99H% C: %	