

## Principles of operation, cross section

The sandwich plate design directional valve elements L8\_1... are compact manual operated valves which control the start, the stop and the direction of the oil flow.

These elements basically consist of a stackable housing (1) with a control spool (2), a block with the control lever (3), and a spring housing (4) with a return spring (5).

The hand operated lever moves the control spool (2) from its neutral-central position "0" to the required position "a" or "b", and the required flow from P to A (with B to T), or P to B (with A to T) is achieved.

**Type L8\_L1\_2S8\_M100** is the valve version in which the return spring (5) brings the spool back to neutral-central position "0" when the manual lever is not operated.

The valve is available with a choice of spool variants (refer to page 3)

**Type L8\_L1\_2S8\_F100** is the valve version with mechanical detent in which the control spool (2) stays in anyone of the 3 achieved positions "0", "a" or "b" when the lever is left free. With this valve, the oil delivery can continue without any action on the lever.

Also this version is available with a choice of spool variants (refer to page 3).

Special types of control are available upon request.

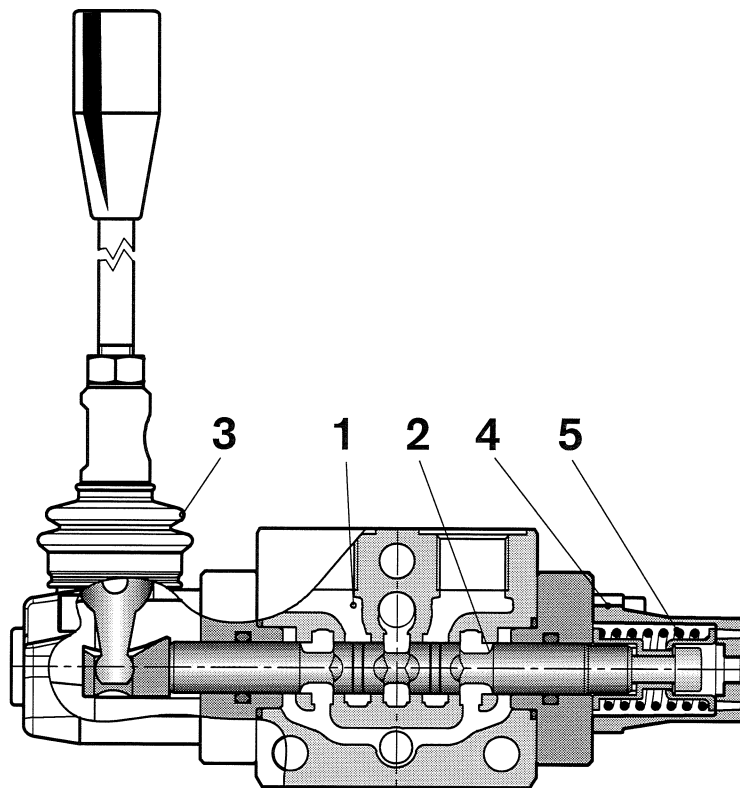

MP-618SK – O-RING KIT

## CROPLANDS PART NUMBERS: MP-618-1 – PRESSURE ADJUST SCREW AND LOCK NUT

Where used: MP-618/MP-619

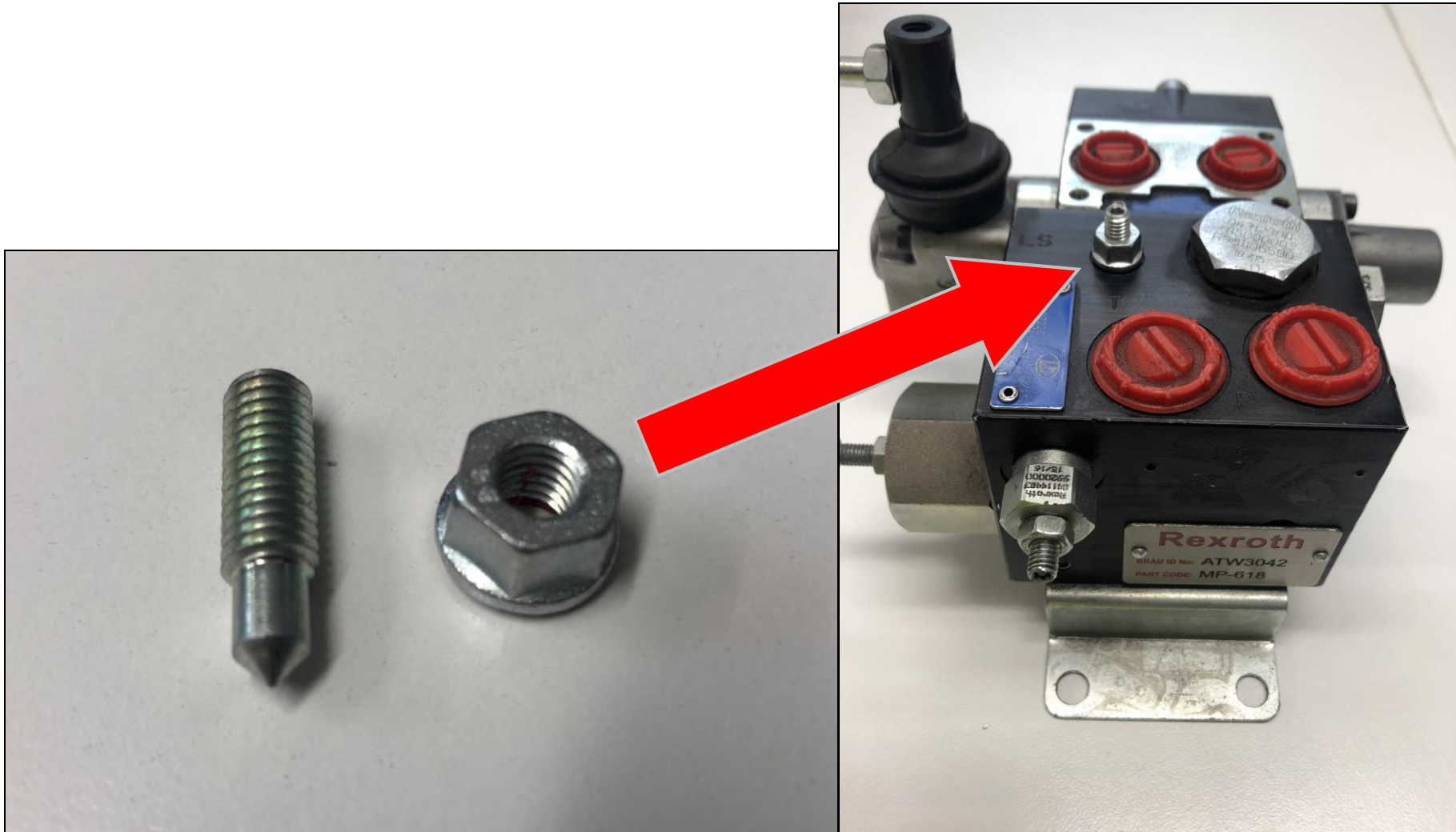

## CROPLANDS PART NUMBERS: MP-618-2 – PRESSURE RELIEF POPPET TYPE CARTRIDGE COMPENSATED

Where used: MP-618/MP-619

