

# MT-3405F™ II

*"Dual Display"*  
**Automatic Rate Controller**



**REFERENCE MANUAL**



**MICRO-TRAK**  
SYSTEMS, INC.

# **MT-3405F™ II**

## ***“Dual Display” Automatic Rate Controller***

### **REFERENCE MANUAL**

The MT-3405F™ II is an electronic monitoring and control system that can help you achieve maximum yields and operate more cost-effectively by providing the information you need to maintain proper application rates of liquid chemicals and fertilizer. The MT-3405F™ II has been designed for easy installation and operation. However, since each installation will vary depending on your equipment, please take time to familiarize yourself with this manual and the actual components before beginning. Following the procedures described in this manual will ensure proper performance and help avoid problems or questions once you are in the field.

This manual is written for the MT-3405F™ II Model MT34F II-04 which may be used for either English or Metric measurement. Please read the manual carefully and follow the instructions as they apply to your usage.

If you do encounter a problem that cannot be corrected by reviewing this manual, consult your dealer or distributor, or contact a Micro-Trak technician for assistance.

**(800) 328-9613 • (507) 257-3600 • Fax: 507-257-3001**  
**www.micro-trak.com • trakmail@micro-trak.com**



**MICRO-TRAK®**  
**SYSTEMS, INC.**

P.O. Box 99  
111 East LeRay Avenue  
Eagle Lake, MN 56024-0099

© Copyright 2007  
Micro-Trak® Systems, Inc.  
Printed in the U.S.A.

# Micro-Trak® Warranty

Micro-Trak (herein "Seller") warrants to the original purchaser (herein "Buyer") that, if any product or part of the product (herein "part") proves to be defective in material or workmanship, upon inspection and examination by Seller, within one (1) year from the original date-of-purchase, and is returned to Seller with dated proof-of-purchase, transportation prepaid, within thirty (30) days after such defect is discovered, Seller will, at their option and sole discretion, either repair or replace said part, except that the warranty for expendable parts, including but not limited to, light bulbs and batteries shall be thirty (30) days from the original date-of-purchase. Said warranty is valid only when the part has been installed, operated and maintained in strict accordance with the procedures outlined in the manual. Any damage or failure to said part resulting from abuse, misuse, neglect, accidental or improper installation or maintenance, unauthorized modification, use with other products or attributable to acts of God, as determined solely by the Seller, will invalidate the warranty. Said part will not be considered defective if it substantially fulfills the performance specification. Buyer shall be responsible for all maintenance services, if any, all in strict accordance with the procedures outlined in the manual. The warranty does not include labor, installation, replacement parts or repairs, delivery of replacement parts or repairs or time and travel. Said warranty is nontransferable.

**THE FOREGOING WARRANTY IS EXCLUSIVE AND IN LIEU OF ALL OTHER WARRANTIES OF MERCHANTABILITY, FITNESS FOR PURPOSE AND OF ANY OTHER TYPE, WHETHER EXPRESS OR IMPLIED.** The Seller's liability, whether in contract, in tort, under any warranty, in negligence or otherwise, shall not exceed the return of the amount of the purchase price paid by the Buyer, and under no circumstance shall the Seller be liable for special, indirect or consequential damages. Seller neither assumes nor authorizes anyone to assume for it any other obligation or liability in connection with said part. No action, regardless of form, arising out of the transactions under this agreement may be brought by the Buyer more than one (1) year after the cause of action has occurred.

Seller agrees to extend the term of the foregoing warranty period should the Buyer return completed warranty registration information, with dated proof-of-purchase, to the Seller within one (1) year from the original date-of-purchase. All conditions and limitations of said foregoing warranty, except the term of said foregoing warranty, shall apply. Said term shall be extended to a total of three (3) years from the original date-of purchase on display consoles and network communication modules, as defined by Seller, and said term shall be extended to a total of two (2) years from the original date-of-purchase on all other parts, except that the warranty for expendable parts, including but not limited to, light bulbs and batteries shall be thirty (30) days from the original date-of-purchase, and except that the warranty for parts manufactured by someone other than the Seller, including but not limited to, shut-off and control valves, DGPS receivers, memory cards and drives, mapping software, flowmeters and pressure sensors shall be one (1) year from the original date-of-purchase.

Buyer accepts these terms and warranty limitations unless the product is returned to Seller, via proper distribution channels and approved return authorization, with dated proof-of-purchase, transportation prepaid, within fifteen (15) days from the date-of-purchase for refund of the purchase price.

Units under warranty should be sent prepaid, with dated proof-of-purchase, within 30 days of discovering defect, to the address below:

**MAIL AND UPS:  
Micro-Trak Systems, Inc. • Attn: Service Department  
P.O. Box 99111 • East LeRay Avenue  
Eagle Lake, MN 56024-0099**

## Extended Warranty Option

It's simple! Just complete the enclosed registration card(s) for this product and mail it in and we'll extend your warranty for up to three years\*, at no additional charge.

**MAIL IN YOUR REGISTRATION CARD(S) TODAY!**

Registration Card information is for internal use only.

\* Some limitations apply. See warranty statement for details.

At Micro-Trak Systems, we believe a product that delivers quality and performance at a low cost is what is needed to help today's operator and the operator of the future compete in the world market.

It is our goal to provide operators with a line of electronic equipment that will help build and maintain an efficient and profitable operation that can be passed on to future generations.

We thank you for your purchase and hope that we can be of service to you in the future.

Micro-Trak Systems, Inc.

# Table of Contents

Table of Contents .....	4-5
Component Parts and Assembly Hardware .....	6-7
MT-3405F II System Layout for Liquid .....	8
MT-3405F II Wiring Diagram for Liquid .....	9
MT-3405F II System Layout with EPD.....	10
MT-3405F II Wiring Diagram with EPD.....	11
MT-3405F II System Layout with Hydraulic Valve .....	12
MT-3405F II Wiring Layout with Hydraulic Valve .....	13
MT-3405F II Bypass Configuration.....	14
MT-3405F II In-Line Configuration.....	15
<b>Installation.....</b>	<b>16-22</b>
Required Tools.....	16
Mounting the Display Console.....	16
Electrical Installation .....	16
Speed Sensor Installation .....	17-18
Magnets.....	17
Attaching Magnets.....	17
Attaching the Speed Sensor.....	18
Connecting the Speed Sensor Cable .....	18
Speed Sensor Options .....	18
Remote Run/Hold.....	19
Mounting and Plumbing Flowmeter .....	20
Installing Flow Sensor Cable .....	20
Manual Pressure Relief Valve .....	21
Range Adjust Valve.....	21
Servo, Throttling Valves .....	21
Electric Relief Valve .....	22
Boom Connections .....	22
Care and Maintenance of your MT-3405F II .....	22
<b>Console Functions.....</b>	<b>23</b>
<b>Calibration .....</b>	<b>24-29</b>
English/Metric Selection .....	24
Calibration Key Function .....	24
Entering Calibration Values .....	24-26
Radar or GPS Speed Sensor Calibration .....	26
Determining the Speed Cal.....	27
Drive Shaft Speed Sensor Calibration .....	27
Test Speed .....	27
Exiting Calibration .....	27
Factory-loaded Calibration Values .....	27
Special Calibration .....	28-29
<b>Operation.....</b>	<b>30-32</b>
Manual Operation .....	30
Automatic Operation .....	31
Data Displayed in Rotary Switch Positions .....	31
Resetting System Counters.....	32
Clearing Counters.....	32

# Table of Contents (cont)

<b>Troubleshooting</b> .....	<b>33-37</b>
Messages/Warnings.....	33
Troubleshooting (general, such as speed is erratic, area count is erratic, display doesn't make sense, etc. ....)	34
Checking Individual Components.....	35
Console Inputs.....	36
Plumbing Troubleshooting Chart .....	37
<b>Plumbing Guidelines</b> .....	<b>37-38</b>
General .....	37
Valve Purpose and Adjustments.....	38
<b>Pre-field System Checkout - Bypass Servo</b> .....	<b>39</b>
<b>Pre-field System Checkout - Inline Servo</b> .....	<b>40</b>
Enter target application test speed into console .....	40
<b>Pre-field System Checkout - Inline and Bypass</b> .....	<b>40</b>
<b>Appendices</b> .....	<b>41-73</b>
Appendix A: Optional speed sensor mounting installation.....	42-43
Appendix B: Fine Tuning Speed/Distance Calibration Value.....	44
Appendix C: Fine Tuning Flowmeter Calibration Value.....	45
Appendix D: Flowmeter Assembly .....	46
Appendix E: EPD for MT-3405F II.....	47-50
Appendix F: MT-3405F II - NH3 Specific.....	51-63
Appendix G: Various Ball Valve Configurations .....	64
Appendix H: Using MT-3405F-II with VRA.....	65
Appendix I: Radar Adapter Cables .....	66
Appendix J: Calculating Planter Drive Ratio and Flow Cal.....	67-68
Appendix K: Motorized Hydraulic Flow Control Valve .....	69
Appendix L: Secondary Boom Control .....	70-71
Appendix M: Conversion Chart .....	72
Appendix N: Replacement Parts .....	73
<b>Notes</b> .....	<b>74</b>

# Component Parts and Assembly Hardware

Before beginning installation, check the carton contents for the following items:

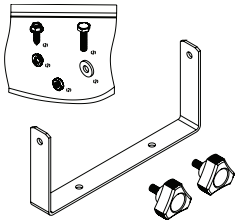

Console Mount Kit  
P/N 13774



MT-3405F™ II Console  
P/N 14880

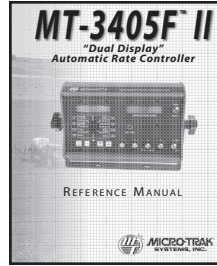

Reference Manual  
P/N 14946

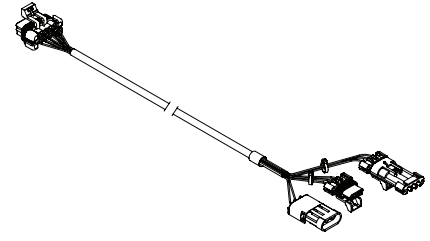

10' Flow, Servo, Pressure,  
Run/Hold, Boom 6 Harness  
P/N 14320

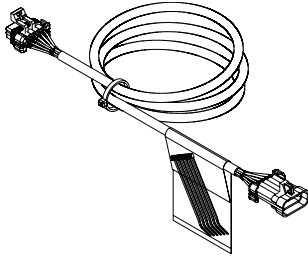

10' 10-Pin M/P Extension  
Cable (1) P/N 13221

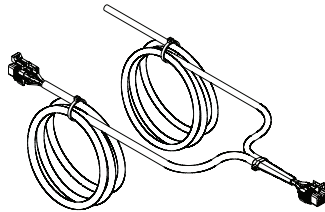

10' Power/Boom Cable  
P/N 14318

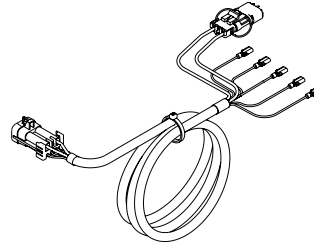

10' Boom Harness (Booms 1-5)  
P/N 17436

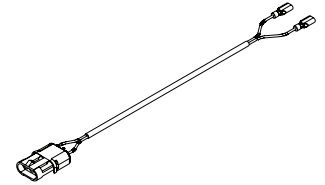

Power Connection to EPD  
P/N 17403

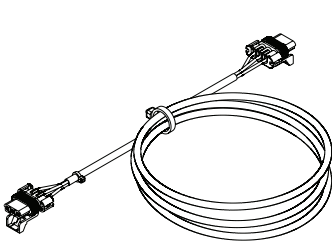

3' 3-pin M/P Speed  
Adapter Cable P/N 14324

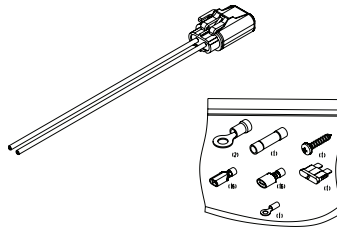

Terminal Kit w/ Fuse Holder  
P/N 13270



14" Nylon Cable Ties  
P/N 12910

### Speed Sensor Kit P/N 01531

*Including items A-F, below:*

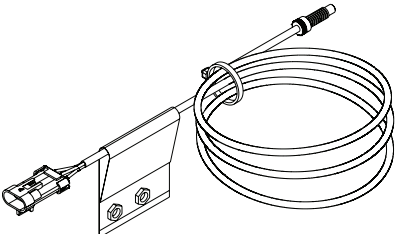

A. 5' Hall-effect Speed/Flow  
Sensor Cable P/N 13096

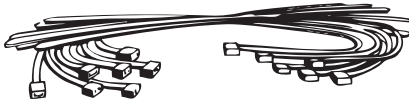

B. 14" Nylon Cable Ties (10)  
P/N 12910

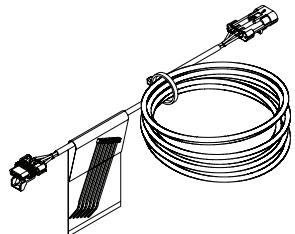

C. 15' 3-Pin Extension Cable  
M/P 150 P/N 13207

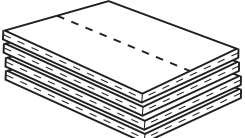

E. Magnets (6)  
P/N 12069  
(2 in hardware bag)

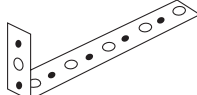

D. Speed Sensor  
Mounting Bracket  
P/N 10013



F. Hardware Bag  
P/N 13251

# Component Parts and Assembly Hardware

## Optional Equipment



1" Electric Servo Valve  
P/N 14928

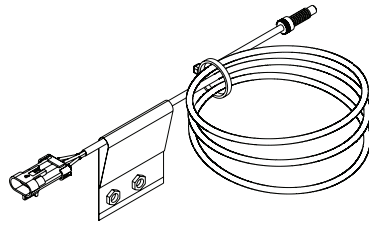

5' Hall-effect Flow Sensor Cable  
with threaded sensor, comes with  
Flowmeter Kit  
P/N 13096

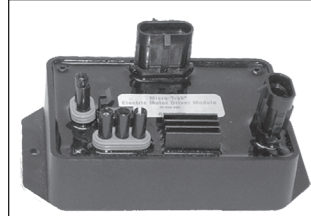

The Electric Motor Driver Kit enables all current Micro-Trak Automatic Rate Controllers to control the rate of flow by regulating the speed of a 12 volt pump. The Electric Motor Driver replaces the electric servo valve. It will control most 12v pumps up to a max of 25 amps. Includes modules and necessary cables  
P/N 14692



1" Flanged Servo Valve  
Kit P/N 01564

OR

1 1/2" Flanged Servo Valve  
Kit P/N 01565

## Flowmeter Kits Available

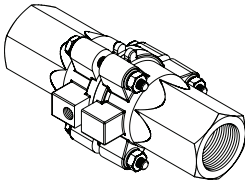

FM1000SS Flowmeter  
P/N 13187  
Kit P/N 01505

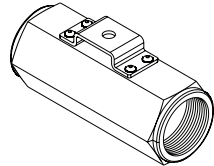

FM1500SS Flowmeter  
P/N 12274  
Kit P/N 01506

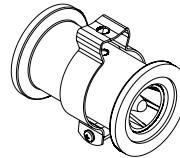

FM270 Flowmeter  
P/N 14286  
Kit P/N 01515

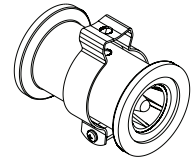

FM10-100 Flowmeter  
P/N 14829  
Kit P/N 01514

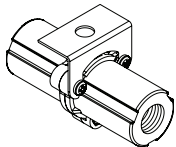

FM500 Flowmeter  
P/N 13269  
Kit P/N 01500

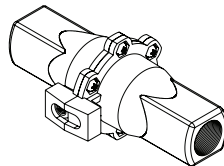

FM750GFN Flowmeter  
P/N 11501  
Kit P/N 01501

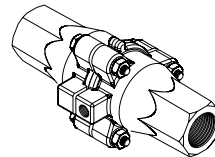

FM750SS Flowmeter  
P/N 10131  
Kit P/N 01504





# MT-3405F II Wiring Diagram for Liquid

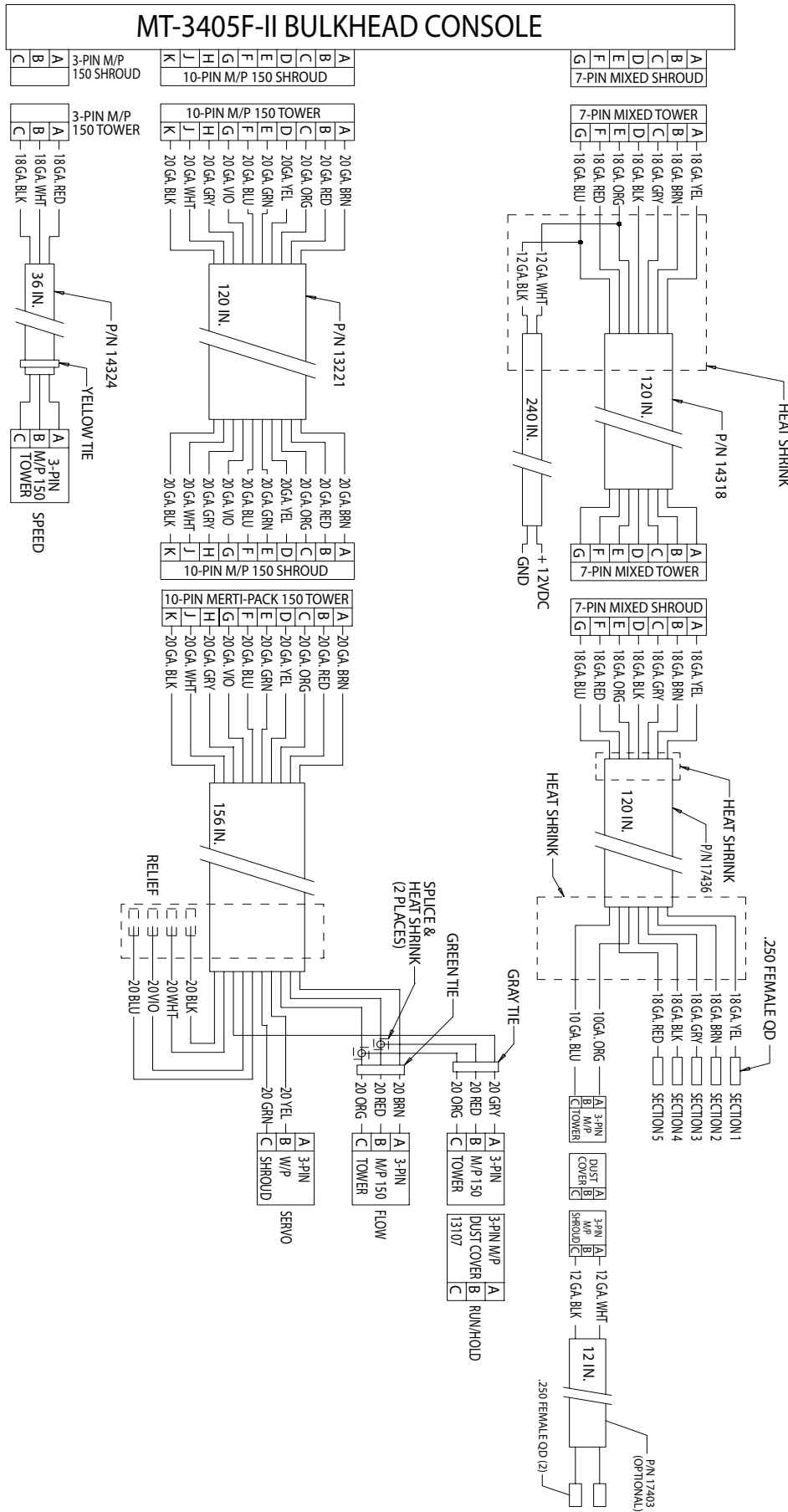

# MT-3405F II System Layout with EPD

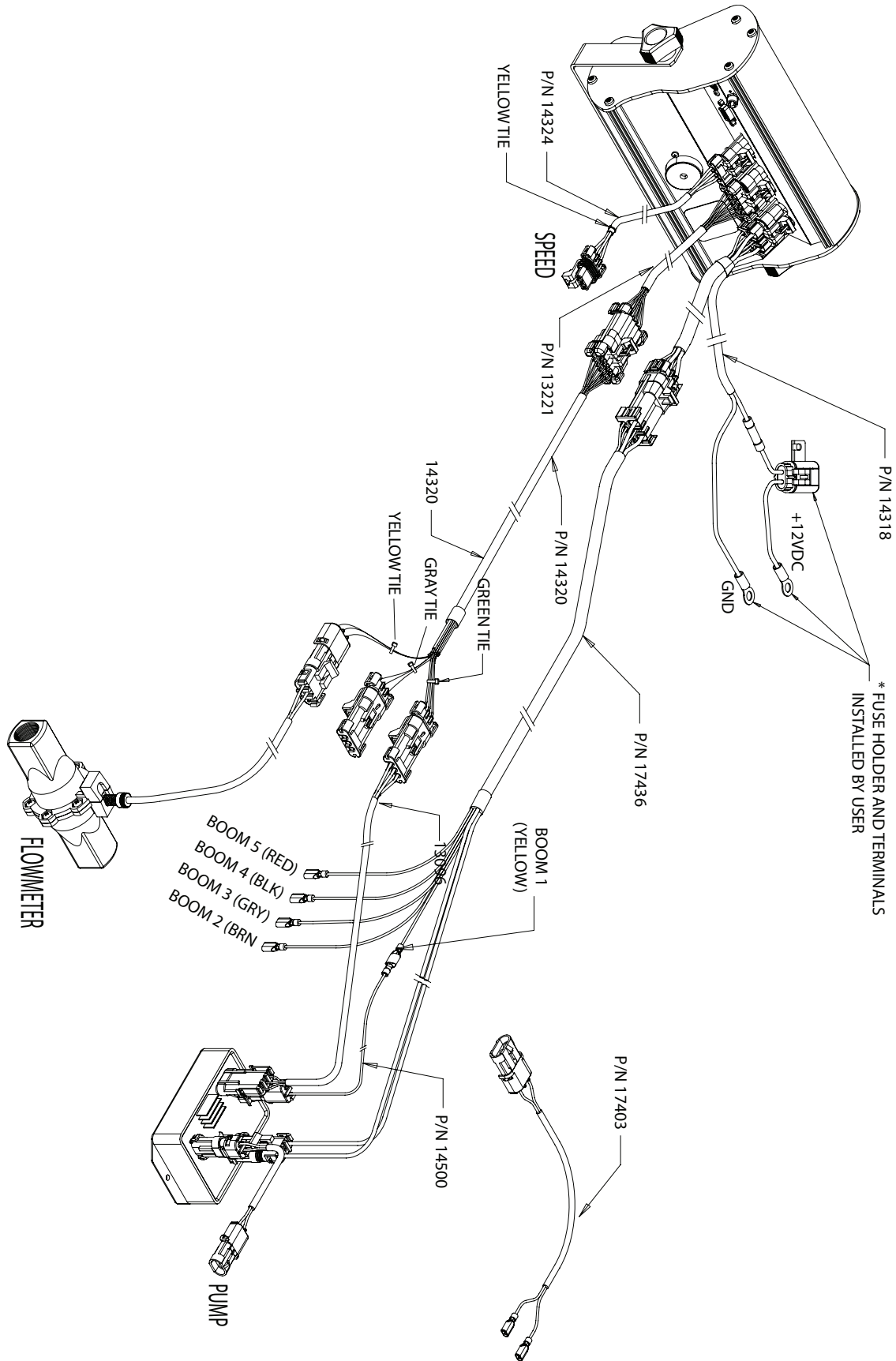



# MT-3405F II System Layout with Hydraulic Valve

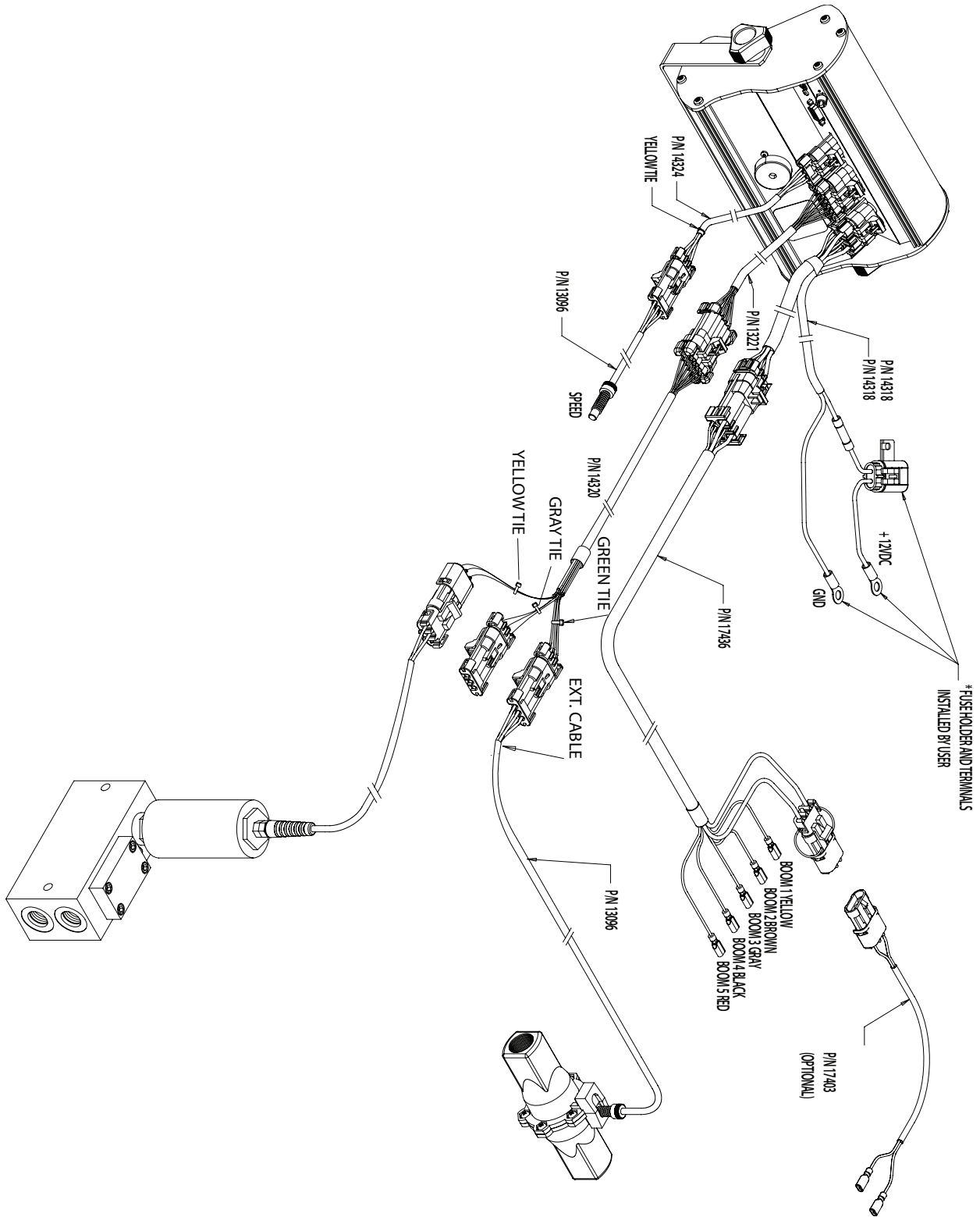

# MT-3405F II Wiring Diagram with Hydraulic Valve

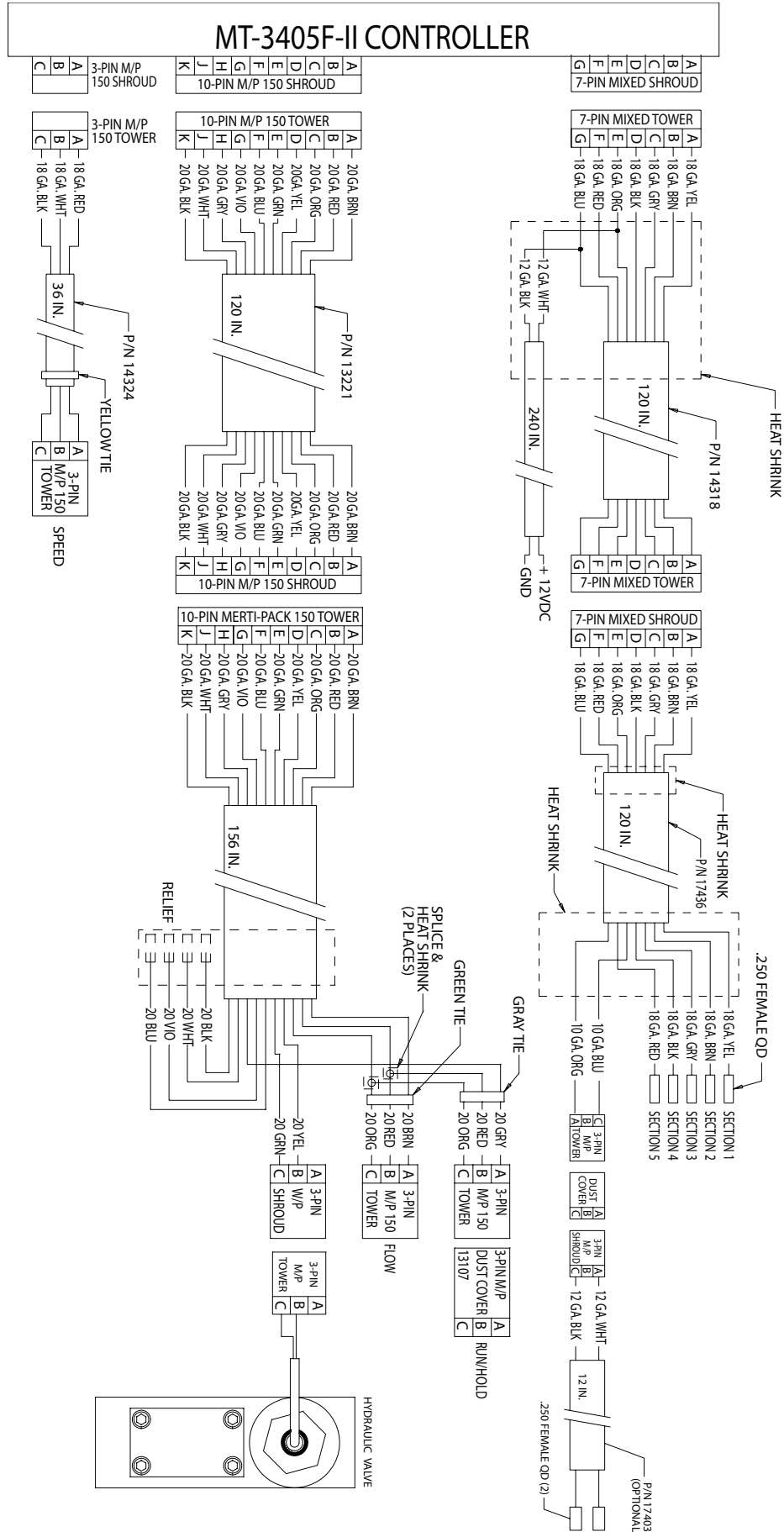

# MT-3405F II Bypass Configuration

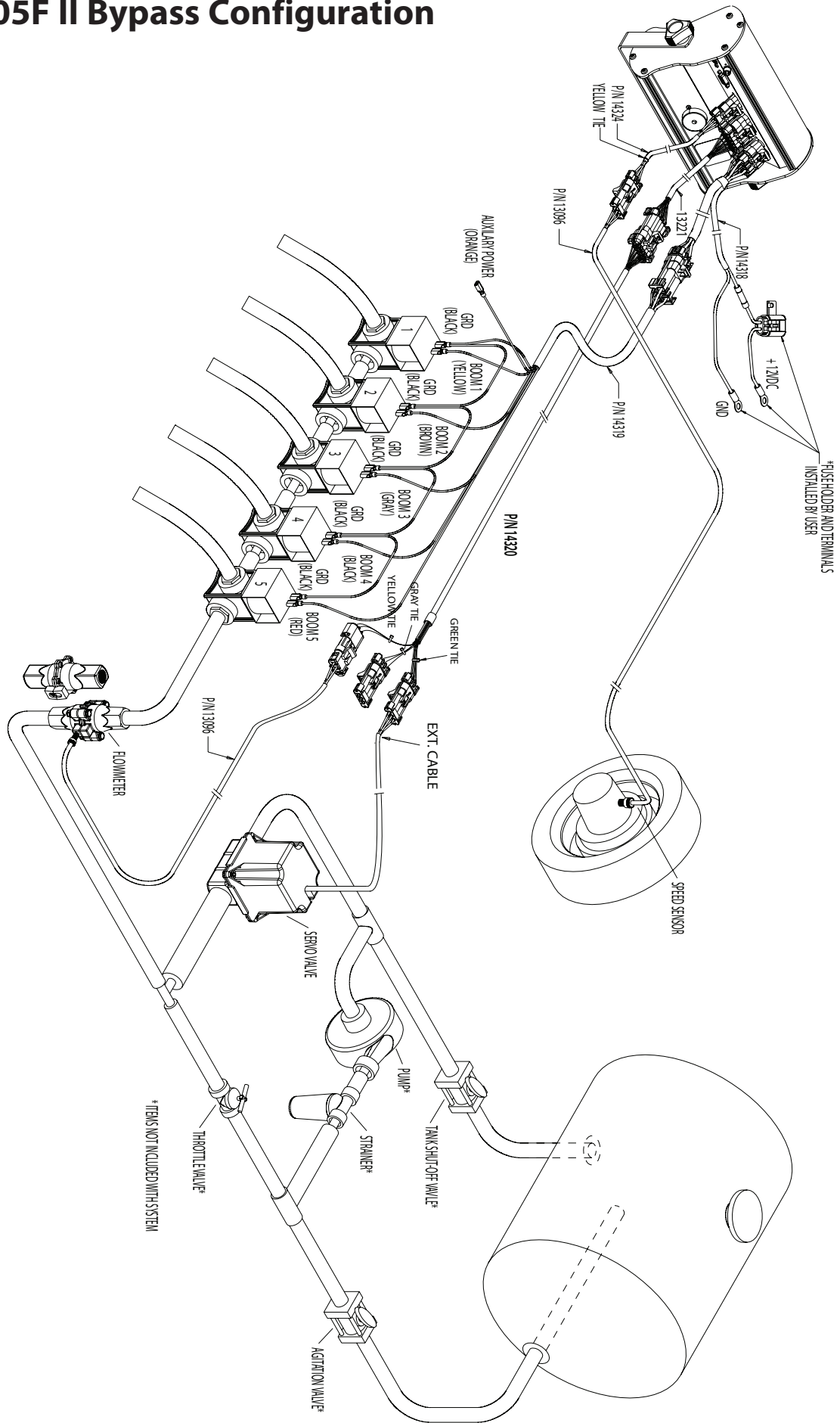

# MT-3405F II In-Line Configuration

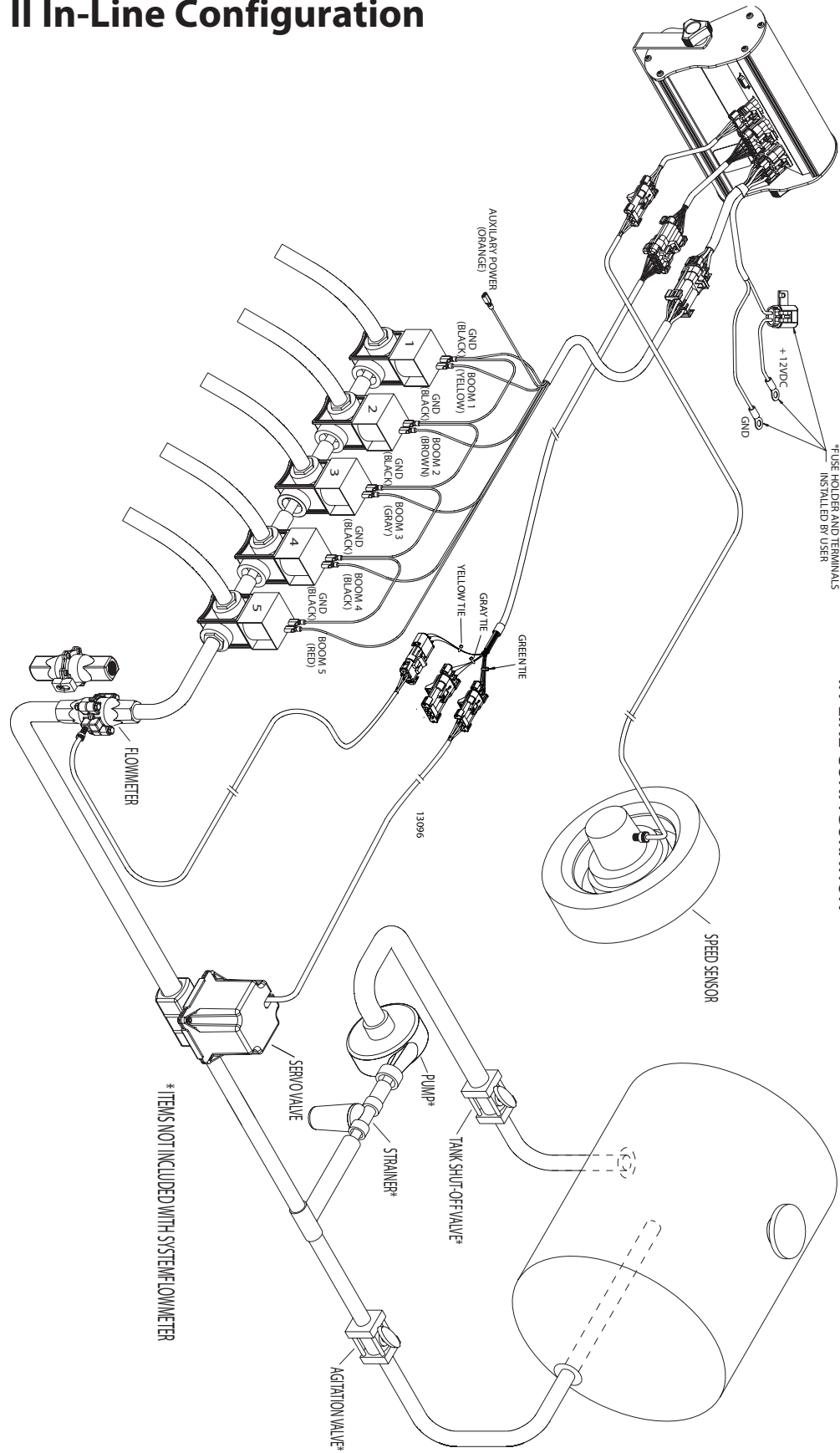

**MT-3405F-II LAYOUT  
IN-LINE CONFIGURATION**

\*ITEMS NOT INCLUDED WITH SYSTEM FLOWMETER

\*USE HOLDER AND TERMINALS  
INSTALLED BY USER

# Installation

## Mounting the Display Console

Select a mounting location which seems most workable, and that best fits your needs. It should be convenient to reach and highly visible to the operator. **DO NOT INSTALL IN A POSITION THAT OBSTRUCTS THE VIEW OF THE ROAD OR WORK AREA.** Whenever possible, avoid locations that expose the console to direct sunlight, high temperature, strong chemicals or rain.

Place the mounting bracket in the selected location, mark holes, drill 1/4" (7mm) holes and mount bracket with bolts, lock-washers and nuts provided. (If bolts are not practical, use self-tapping screws.) *See Illustration 1.*

Insert the console in the "U" bracket and install the console knobs through the bracket, placing a rubber washer over the threaded stud. Position console to proper viewing angle and tighten the knobs securely.

### Tools Needed to Install MT-3405F™ II

- Screwdrivers
- Set of Wrenches
- Electric Drill and Bits
- Center Punch
- Pliers
- Wire Cutter
- Hammer
- 12-Volt Test Light

Illustration 1

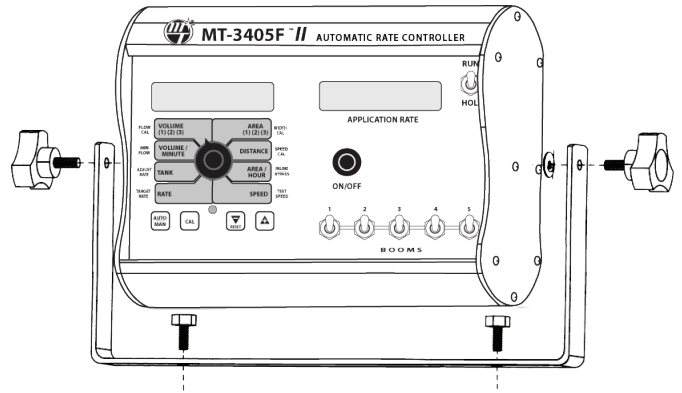

## Electrical Installation

The MT-3405F™ II must be connected to a 12-volt DC electrical system. Power is connected directly to the battery. The MT-3405F™ II has an ON/OFF switch on the console to turn the power off when the system is not being used.

Locate the power cable harness and connect to the mating connector on the console. Connect the blue chassis ground wire to a good frame ground. See Illustration 2. Make sure there is good metal-to-metal contact. Route the power cable from the console to the battery. Cut off excess length. In routing cable to battery, avoid areas where the cable may be subjected to abrasion or excessive heat. Install the in-line fuse provided with the kit on the white wire, as illustrated, to protect the circuit. Connect the ORANGE wire (hot) to the positive battery terminal. Attach the BLACK wire (ground) to a screw or bolt on the equipment frame. *See Illustration 2.* Be sure there is good metal-to-metal contact.

Your MT-3405F™ II is equipped with a non-volatile electronic memory which does not require a constant supply of power to retain daily totals or calibration values. The advantage with this type of memory is that it conserves battery power and will not discharge the vehicle's battery when equipment is not in use.

Illustration 2

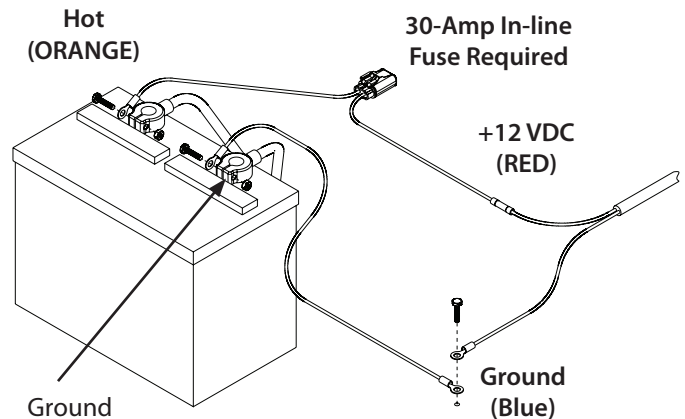

**NOTE: For negative ground systems only.**



# Installation (cont)

## Speed Sensor Installation

**Installation Note:** The console provides one connection point for the speed sensor. A 15 ft. extension cable is provided. For speed sensor installations on implements, add 3-pin extension cables as required.

**Please Note:** If you have purchased a Vansco radar or other radar or GPS speed sensor, disregard the following section on magnetic speed sensors and install the Vansco or other radar as described in the instructions included with the unit. You will need an adapter cable to connect to radar or GPS Speed Sensor, see Appendix H.

### Locations where the sensor may be installed:

1. Non-driven wheel on tractor, vehicle or implement. This is less susceptible to errors resulting from wheel slip.
2. Tractor, vehicle or planter drive shaft. This type of mounting is recommended for trucks, four-wheel drive tractors or other equipment that has poor or no access to a non-driven wheel. See Appendix A for magnetic speed sensor installation details for various types of wheels or drive shaft.

#### Locate the following parts:

- Speed sensor cable (green body)
- Mounting "L" bracket
- Magnets
- Cable ties

## Magnets

Please read the following information about magnet spacing and polarity.

The number of magnets that must be used depends on the size of your tire and where you mount the sensor. On tractor or implement wheels the general rule of thumb is one magnet for each wheel bolt (minimum of two, and always an even number). For drive shafts or small wheels (ATV's), two magnets are usually adequate.

Some installations may require that more than two magnets be installed. To determine the number of magnets required, measure the distance traveled of one revolution of the sensor equipped wheel in inches (centimeters).

See the following tables to find the minimum number of magnets required (always an even number)

### English or Turf (inches)

<b>Wheel Circumference</b>	40	80	120	160	200
<b>Number of Magnets</b>	2	4	6	8	10

### Metric (cm)

<b>Wheel Circumference</b>	100	200	300	400	500
<b>Number of Magnets</b>	2	4	6	8	10

The magnets provided by Micro-Trak are marked with a punched dashed line on the SOUTH pole side of the magnet. See Illustration 3A.

Always use an even number of magnets, and always alternate the polarities of the magnets as you go around the wheel hub or drive shaft.

To install, mount the first magnet with the SOUTH pole side (dashed line) facing toward the hub or shaft. Mount the second magnet with the NORTH pole side facing toward the hub or shaft. See Illustration 3B.

For proper operation, the magnets must be evenly spaced around the wheel or drive shaft. The magnets must be at least 1" apart. See Illustration 3C.

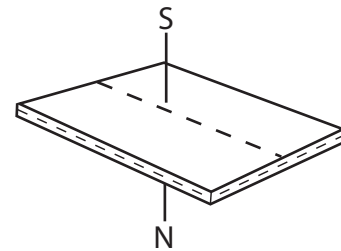

Illustration 3A

Illustration 3B

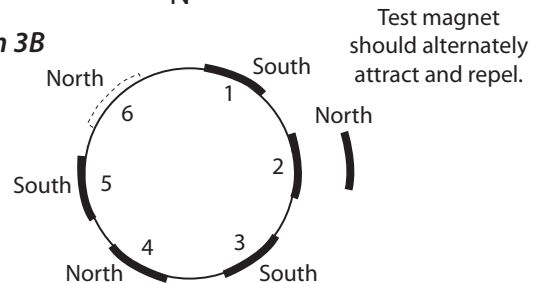
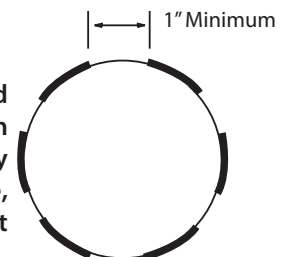

Illustration 3C

NOTE: Magnets may be attached mechanically or adhered with epoxy or other high quality adhesive. When using adhesive, thoroughly clean the area of dirt and oil.



## Installation (cont)

### Attaching the Speed Sensor

The magnets are attached to a wheel hub or drive shaft and the speed sensor is mounted directly over the magnet. When the wheel or drive shaft begins turning, a speed impulse is sent to the MT-3405F™ II console every time a magnet passes by the tip of the speed sensor. For the speed sensor to operate properly, the spacing between the magnets and the tip of the sensor must always remain constant. Before permanently mounting any parts, be sure that the location you have selected will meet the requirements shown in *Illustration 4*.

**NOTE:** Observe magnet polarities (see previous section).

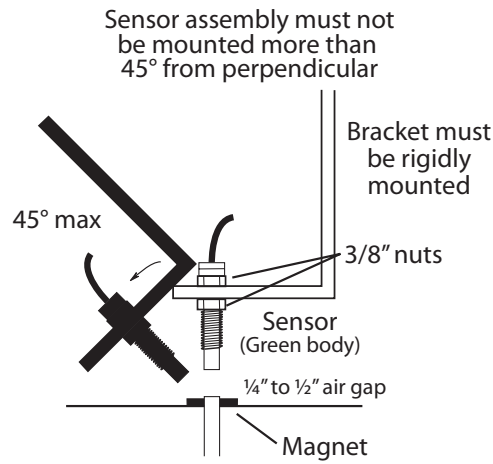

*Illustration 4*

### Connecting the Speed Sensor Cable

The speed sensor cable has a GREEN sensor body and mates with the 3-pin connector which is marked with a yellow cable tie. The speed sensor and the flow sensor are identical, but must be connected to the proper harness connector. The speed sensor always connects to the 3-pin M/P connector with the YELLOW tie and flow sensor always connects to the 3-pin M/P connector with the GREEN tie. *See MT-3405F II Wiring Diagram on page 9.*

The optional Run/hold sensor, also uses the same type of connector as the speed and flow sensors. However, the Run/hold sensor has a GRAY tie near the 3-pin connector, the sensor body is BLACK, and it always connects to the main harness lead with the GRAY tie. *See MT-3405F II Wiring Diagram on page 9.*

**SENSOR IDENTIFICATION CHART**

SENSOR	SENSOR BODY COLOR	MAIN HARNESS TIE COLOR
Speed	Green	Yellow
Flow	Green	Green
Run/Hold	Black	Gray

### Speed Sensor Options

**NOTE:** In addition to the standard Hall-effect magnetic speed sensor, the MT-3405F II may be interfaced with a variety of other speed sensing equipment. Several options are listed below.

#### ASTRO SERIES OR OTHER GPS SPEED SENSOR INTERFACES

The MT-3405F™ II may also be used with most GPS speed sensors that output a pulsed signal, such as the Micro-Trak Astro II and 5, SkyTrak or Dickey-John GPS speed sensors. An adapter cable may be required.

#### VANSCO™ RADAR SPEED SENSOR

The Vansco radar speed sensor uses a microwave (radar) signal to deliver a reliable, accurate speed signal for electronic equipment. It features state-of-the-art electronic design/manufacturing, rugged aluminum housing and complete testing and certification.

#### RADAR INTERFACE

The MT-3405F™ II may also be interfaced with most popular radar ground speed sensors. An adapter cable is required for proper interface.

**SEE APPENDIX I FOR LIST OF ADAPTER CABLES FOR RADAR.**



**Astro 5 GPS Speed Sensor**



**Vansco Radar Speed Sensor**

**Contact a Micro-Trak sales representative for details on any of these products, or call Micro-Trak Systems, Inc. at 1-800-328-9613.**

# Installation (cont)

## Remote Run/Hold

To use the remote Run/Hold feature, the connector with the gray wire tie at the end of the Flow/Servo harness. (**See Wiring Diagram below**). If using a switch, connect the switch (not supplied) across the 2 pins on the connector, or to the 2 wires behind the connector. Switch OPEN = Run, Switch CLOSED = Hold.

This could be done nearer the console by connecting one switch terminal to ground, and the other switch terminal to the gray wire on the 10-pin connector on the back of the console.

If using the Micro-Trak Hall-Effect Run/Hold Sensor Kit, connect the sensor cable to the connector with the gray tie. When installing the sensor kit, mount so that when the sensor is near the magnet the system is in HOLD and when the sensor is away from the magnet the system is in RUN.

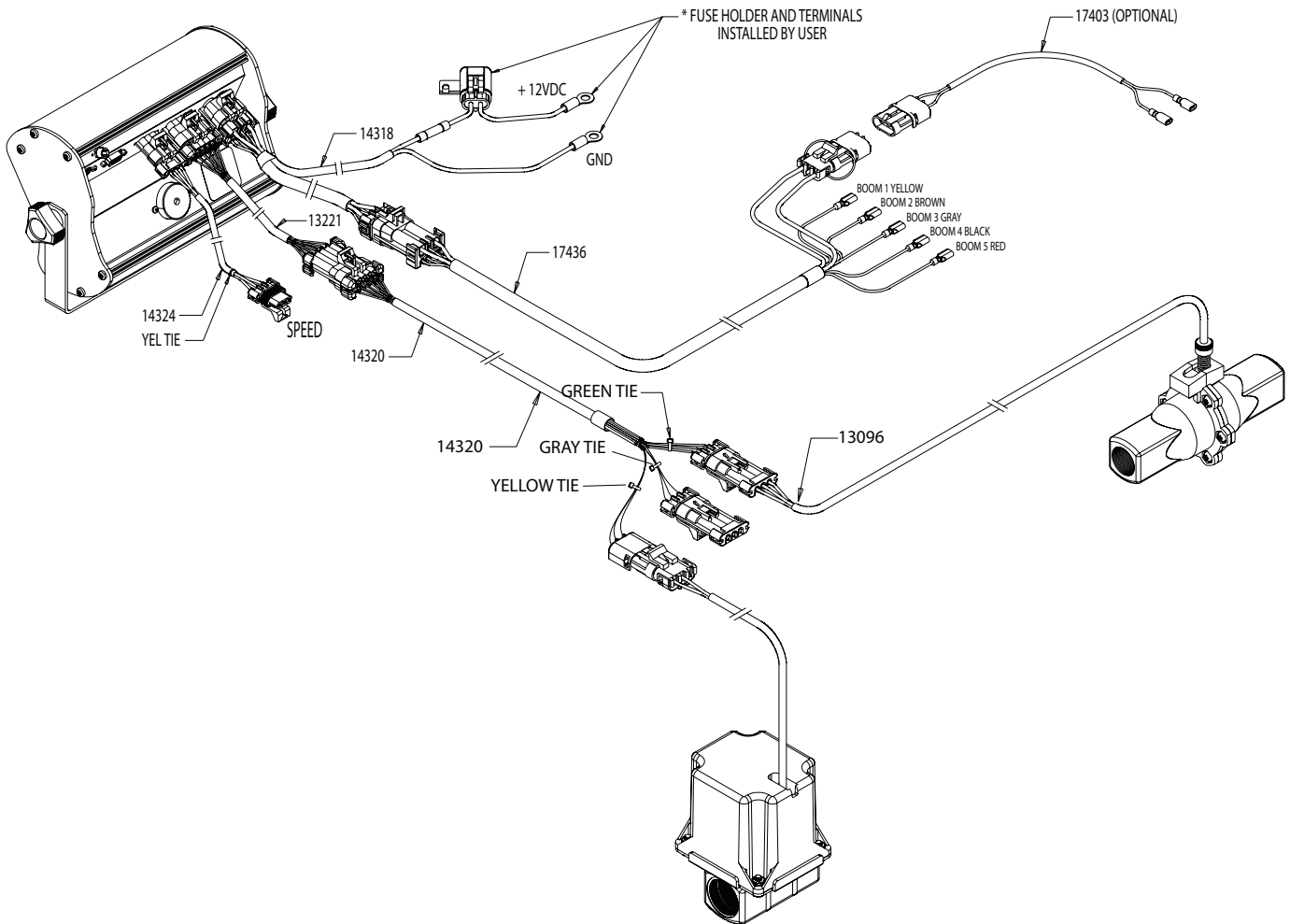

## Installation (cont)

### Mounting and Plumbing Flowmeter

The Flowmeter must be installed in the main boom line after any strainers, return lines, or valves. Securely mount flowmeter (hardware not supplied) in a vertical position in an area away from intense vibration. DO NOT install flowmeter closer than 12" to the servo valve or the boom shut-off valves. The flow meter is a bidirectional meter (exception: Polmac's 1 1/2"—3"). Liquid can flow in either direction, but up is preferred, especially at rates below 5 GPM (19 lpm). Make connections using appropriate fittings without the use of reducers, elbows or sharp bends for a minimum of six inches (15 cm) either side of meter. *See Illustration 5.* Save plastic plugs to protect flowmeter during storage. (The flowmeter may need periodic cleaning, so it should be easy to remove.)

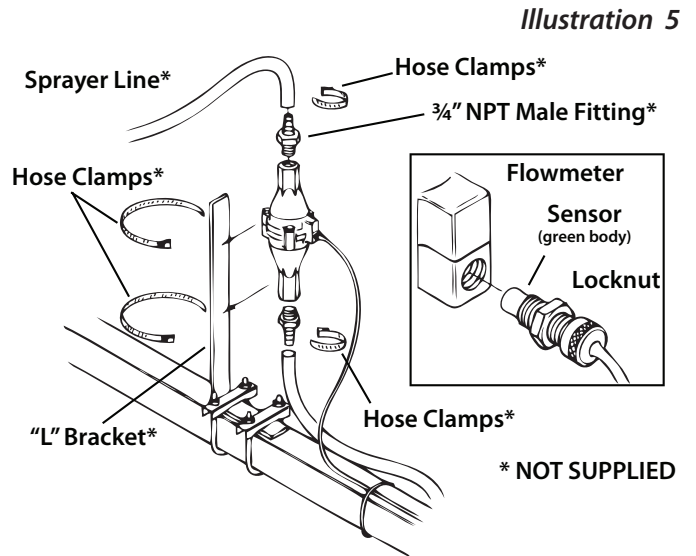

### Installing Flow Sensor Cable

With the flowmeter in place, install the flow sensor cable.

The flow sensor cable has a GREEN sensor body and mates with the 3-pin connector on the main harness marked with a GREEN cable tie. Screw sensor all the way into hole of flowmeter. Tighten 3/8" jam nut to secure sensor in place.

Uncoil flow sensor cable and carefully route it to meet the main harness flow connector marked with GREEN tie. Align connectors and press firmly together until locking tab clicks into place. Secure cable with ties provided. *See Illustration 6 and MT-3405F II Wiring Diagram on page 9.*

**Note:** Sensors with GREEN bodies can be used for either SPEED or FLOW but not for RUN/HOLD.

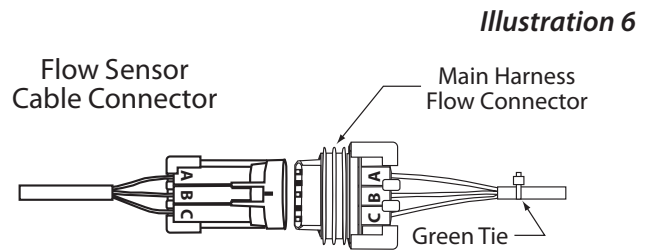
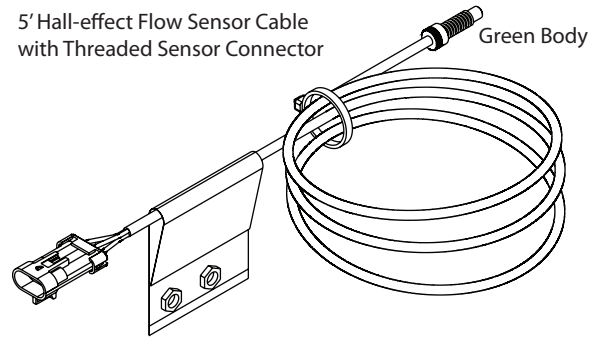

Connect flow sensor cable to green-tie console cable.

## Installation (cont)

### Manual Pressure Relief Valve

If you have a positive displacement pump or a centrifugal pump capable of generating excessive pressure, you must install a pressure relief valve and adjust it to a safe maximum pressure. If a positive displacement pump is operated without a pressure relief valve, damage may result to pump or other plumbing component. See *Illustration 7*.

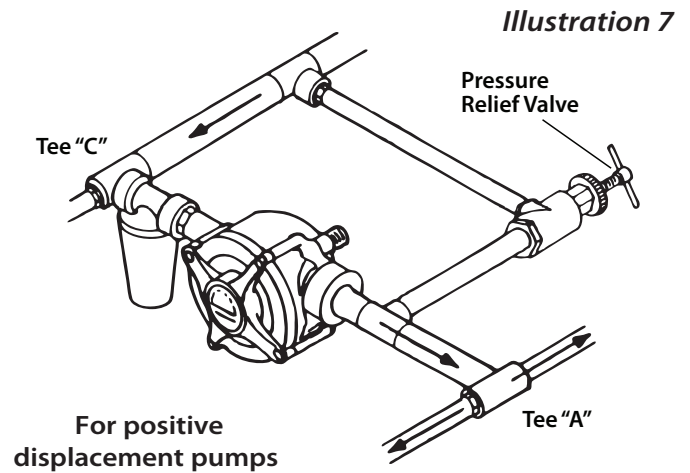

### Range Adjust Valve

With oversized pumps, it may be necessary to install a range adjust valve. The range adjust valve will reduce the pump's output to the rest of the system. Adjustment of this valve is covered in the Pre-Field System Checkout, pages 39-40. See *Illustration 8*.

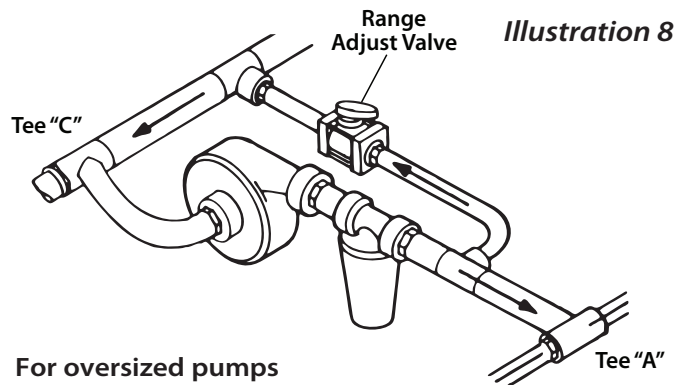

### Servo, Throttling Valves

For **BYPASS** installations, the servo valve installs in an unrestricted return line to the inlet of the pump or directly into the tank. The console must be calibrated for bypass operation, see *Calibration section*. **DO NOT** install the servo valve closer than 12" to the flowmeter. The servo valve has a flow direction decal on it. Make certain that the actual flow direction matches the decal on the servo valve. Do not install the servo valve in the agitation line. Slow response time and marginal operation may result. The return line should tee from the main line just after the throttling valve. See *Illustration 9*. The throttling valve is used to limit the output (set maximum output) of the pump to the flowmeter and servo valve. The throttling valve is adjusted to put the servo valve in its optimal operating range. Please refer to *Pre-Field System Checkout on pages 30-40 for proper valve adjustment procedure*.

The servo valve connects directly to the 3-pin connector on the main harness. If more length is required, use a 3-pin W/P extension cable of the appropriate length.

**IMPORTANT NOTE:** If using the MT-3405F™ II with an old style Micro-Trak servo valve, the valve voltage must be set to 8 volts. See *Special Calibration Valve Voltage section on page 29*.

**NOTE:** The servo valve may be installed in the main spray line as shown in *Illustration 10*. For in-line installations, you will need to calibrate the system for **INLINE** operation, see page 26.

#### BYPASS

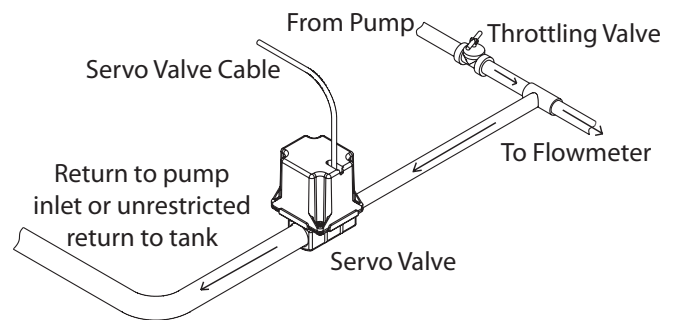

#### INLINE

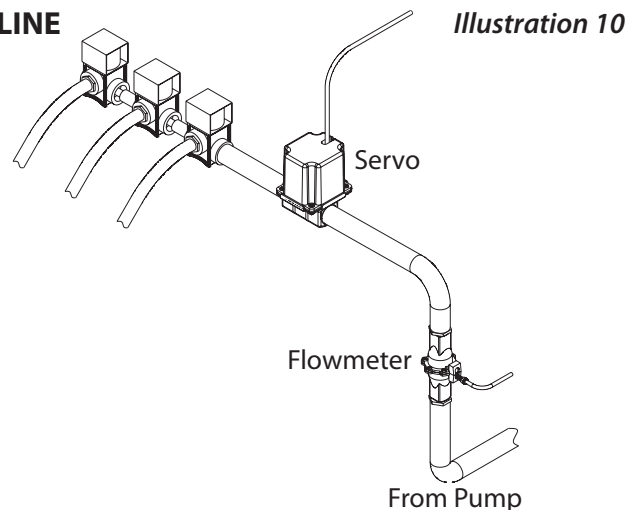

## Installation (cont)

### Electric Relief Valve

The relief valve is used to “dump” pressure when your boom valves are turned off. Whenever all the boom control switches are turned off, or when HOLD is selected with the master switch, the relief valve should be open. **Use Illustration on the right** as your pattern for proper installation if your relief valve has a flow-through port. **DO NOT** install the relief valve closer than 12” to the flowmeter. With the relief valve installed, locate the violet wire (tied back on flow/servo cable) and crimp a female terminal on the violet wire and connect to relief valve terminal. Connect other terminal on relief valve to ground.

If your relief valve does not have flow-through port, you must add a “T” fitting. **NOTE: To assure a good connection and avoid corrosion, coat electrical connections with silicone grease.**

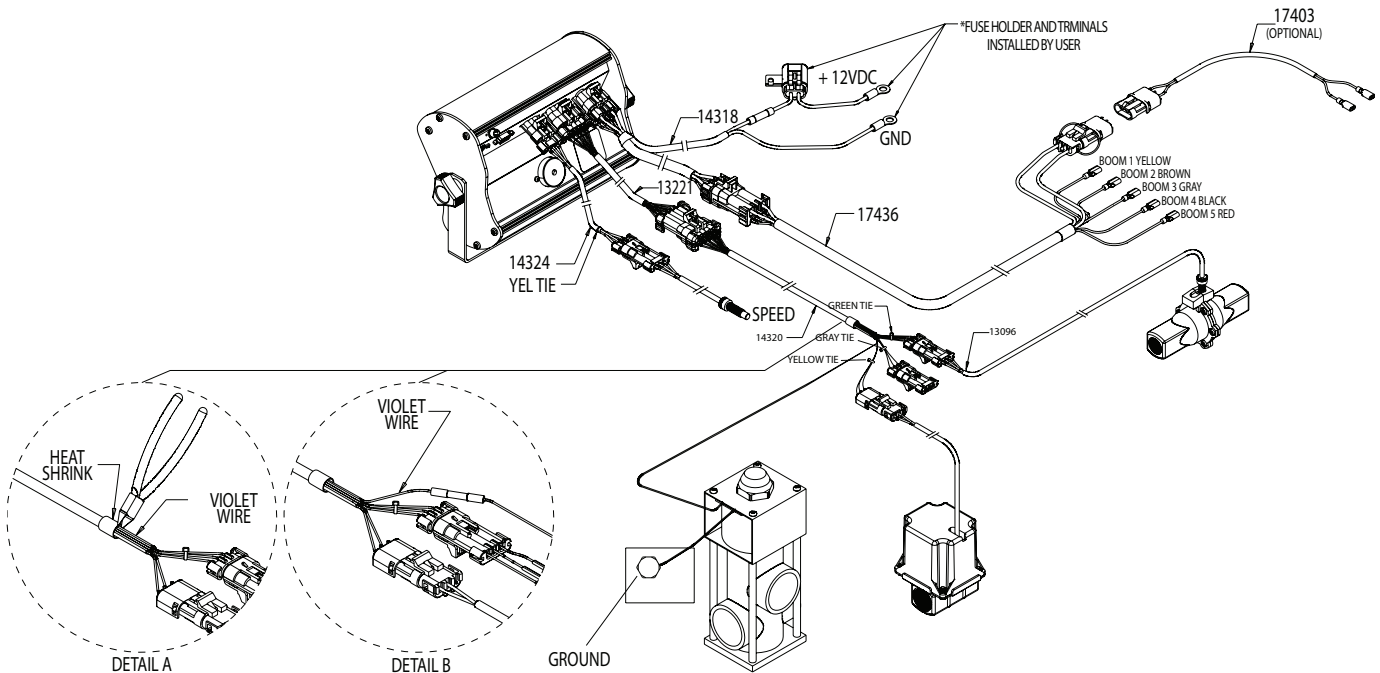
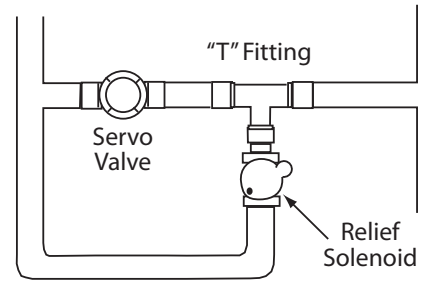

## MT-3405F™ II Boom Connections Boom Shut-off Valves

Boom valves of differing designs may require a “T” fitting. Make certain to use adequately sized plumbing lines to avoid excessive pressure drops. **DO NOT** install the shut-off valves closer than 12” to the flowmeter.

Locate the boom shut-off harness. The boom wires are color-coded. (If valves have wires, crimp terminals on those wires.) Attach the cables to the terminals on the boom valves. Attach a ground terminal to each valve. If valves operate backwards, reverse connections. Apply silicone grease to the terminal connections to help prevent corrosion and insure a good electrical connection.

**IMPORTANT:** See complete wiring diagram on page 9.

**NOTE:** to configure your system using motorized ball valves, see Appendix G.

### Care & Maintenance of your MT-3405F™ II Console

Store the console in a cool dry location if it will not be used for an extended period of time, such as during the off-season.

As with any electronic equipment, use care in cleaning so that water or other liquids do not enter the case.

Thoroughly rinse Flowmeter with clean water, install plastic shipping plugs and keep from freezing.

#### PRECAUTIONS

- The input pressure on the glass-filled nylon flowmeter FM750 GFN should not exceed 150 PSI (1034 kpa).
- Do not expose the flowmeter to liquid temperatures exceeding 130 degrees F (55 degrees C).
- Some chemicals may damage the NORYL turbine or the nylon body of the flowmeter. If you are in doubt, contact the chemical manufacturer.

# Overview of MT-3405F™ II Console Functions

The MT-3405F™ II features two large, easy-to-read liquid crystal displays and a lighted panel for night use. The right-hand display always shows the application rate and the left-hand display shows data selected by the rotary switch. Press the On/Off button to turn console on or off.

**VOLUME (1) (2) (3):** Displays total gallons (liters) or lbs. (kg) of NH<sub>3</sub> applied. May be reset. (Note: VOLUME and AREA counters work in pairs, if VOLUME counter 1 is reset, it also resets AREA counter 1).

**AREA (1) (2) (3):** Keeps a running count of the total acres (hectares) worked. May be reset. (Note: VOLUME and AREA counters work in pairs, if AREA counter 1 is reset, it also resets VOLUME counter 1).

**VOLUME/MINUTE:** Displays total gallons (liters) of liquid applied per minute, or lbs. (kg) NH<sub>3</sub> per minute.

**TANK:** Displays gallons (liters) of liquid remaining or lbs. (kg) of NH<sub>3</sub> remaining.

**RATE:** Displays application rate GPA(LPH), or lbs. N/acre (kg of N/hectare).



**DISTANCE:** Displays distance traveled in feet (meters). May be reset.

**AREA/HOUR:** Displays current work rate in acres per hour (hectares per hour).

**SPEED:** Displays ground speed in miles per hour (kilometers per hour).

## Calibration Positions

**FLOW CAL:** Used in calibration mode to enter the calibration value assigned to your flowmeter (see flowmeter tag.)

**MIN FLOW:** Used in the calibration mode to enter the minimum flow rate (GPM/LPM) of the spray boom.

**ADJUST RATE:** Used in calibration mode to enter an amount of change for on-the-go adjustments to the target rate (GPA/LPH), or lbs/acre (kg/hectare) N.

**TARGET RATE:** Used in calibration mode to enter the target application rate (GPA/LPH) or lbs/acre (kg/hectare) N.

**WARNING LIGHT:** Indicates over or under application of plus or minus 10% from the Target Rate or if the tank is low. Also lit when in CAL.

## Calibration Positions

**WIDTH CAL:** Used in calibration mode to enter the working width of your sprayer booms or other equipment.

**SPEED CAL:** Used in calibration mode to enter the speed calibration number in inches (cm) per pulse.

**INLINE/BYPASS:** For establishing servo polarity. (If servo is in the main spray line, select "Inline". If servo is installed in a return line, select "Bypass".)

**TEST SPEED:** Used in calibration mode to enter a test speed in miles per hour (kilometers per hour).

### Key Functions:



**ON / OFF**

**ON/OFF:**

Press to turn the console ON or OFF. Left-hand display shows hours of operation for 2 seconds, then software version for 2 seconds, then begins normal operation.



**AUTO/MAN:**

Key which changes operation from automatic control to manual.

**CAL:**

This key is used to enter & exit the calibration mode.



**PROGRAM KEYS:**

Used to increment and decrement the different calibration values.

- RESET when not in CAL, clears the selected counter when held for two seconds.
- When in CAL, the "+" key increases and the "-" decreases the value displayed.



# Calibration

## English or Metric?

The MT-3405F™II is capable of displaying information in American English or standard Metric measurement. The MT-3405F™II is shipped from the factory programmed for English. **NOTE: The following procedures will also load factory default calibration values. To simply change units without loading defaults, see the “Special Calibration” section.**

### METRIC

- You must be in HOLD or have all booms OFF to enter Cal. To activate the Metric mode, turn power OFF and place the rotary switch at “AREA.” Hold down both the “CAL” and “-” keys and turn power ON. **See Illustration 11.** The console will display LOAD. Once LOAD is displayed, release the two keys. To “lock-in” Metric mode you must enter and exit calibration. Press and hold the CAL key until “CAL” icon appears on the display. The console is now in calibration and Metric mode is selected. Exit CAL by pressing and holding the “CAL” key until CAL disappears from the display (approximately 1 second). **NOTE: You must exit CAL to lock in Metric units.**

### ENGLISH

- You must be in HOLD or have all booms OFF to enter Cal. To activate the English mode, turn power OFF and place the rotary switch in the VOLUME position. Hold down both the “CAL” and “-” keys and turn power ON. The console will display LOAD. Once LOAD is displayed, release the two keys. To “lock-in” English mode you must enter and exit calibration. Press and hold the CAL key until “CAL” lights on the display. The console is now in calibration and English mode is selected. Exit CAL by pressing and holding the “CAL” key until CAL disappears from the display (approximately 1 second). **NOTE: You must exit CAL to lock in English units.**

## Entering Calibration Values

To enter or change any of the system’s calibration values, you must enter calibration mode. To enter calibration mode, STOP the vehicle, turn all booms OFF or put the console in HOLD and press and hold the CAL button until the “CAL” icon appears (approximately one second). **(NOTE: Calibration may be entered while moving, but it is not recommended to attempt calibration while the vehicle is moving.)** The console will remain in calibration mode, with the RED warning light illuminated until you exit calibration or turn power OFF.

Once in calibration mode, you may change any one, all, or none of the values, in any order.\* To select a calibration position, simply turn the rotary selector to the desired position. Calibration positions are identified by the WHITE labeling on each side of the rotary selector. All values are entered and adjusted using the “+” and “-” buttons on the front panel.

**\*TEST SPEED MUST BE LAST.**

Hold the “CAL” key again for 1 second to exit calibration. “CAL” will disappear from the display.

**NOTE: You must exit CAL to save changes.**

Illustration 11

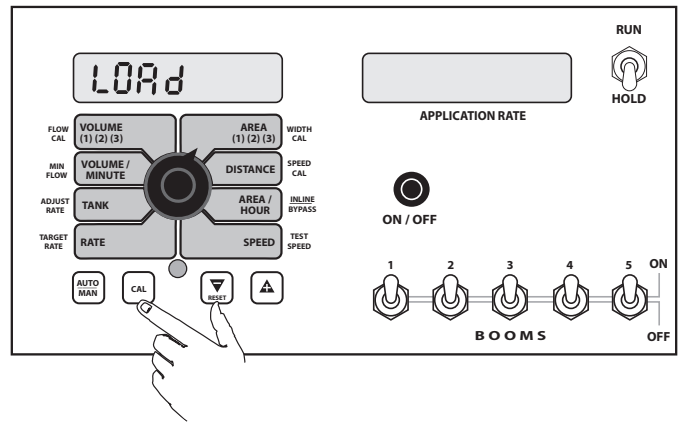

**NOTE: In metric, the width will have a decimal point, in English there is no decimal point. Also, changing from English to Metric mode may change or alter any previously entered calibration values. After switching measurement modes, confirm that all calibration values are correct.**

Illustration 12

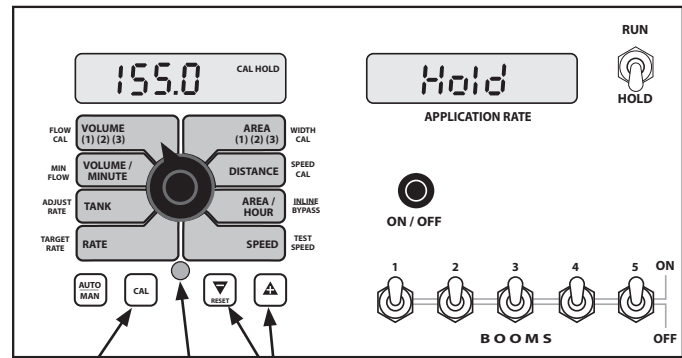

Press to enter or exit calibration mode.

Press to increase or decrease values.

Red warning light will be lit when in CAL.



# Calibration (cont)

## Entering Calibration Values (cont)

**TARGET RATE:** Enter the value for the desired target application rate in gallons per acre (liters per hectare) or lbs. of N per acre (kgs of N per hectare). This is the application rate that the console will lock onto when operating in AUTO.

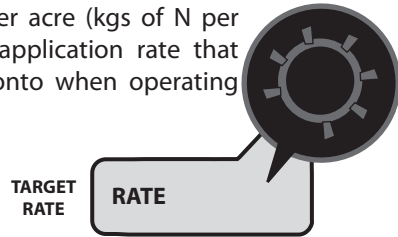

**ADJUST RATE:** Enter the value for the desired amount of change in gallons per acre (liters per hectare) to be used for making on-the-go rate adjustments when operating in AUTO. For example, if a value "1.0" is entered, you will be able to increase or decrease your application rate in one-gallon (liter) or lb. (kg) increments during operation in AUTO. To disable this feature, simply enter ".0" for a value.

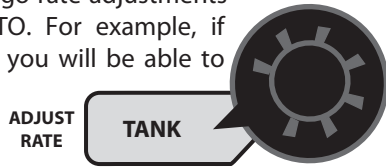

**MIN FLOW:** The purpose of this calibration value is to prevent the system from applying below the recommended minimum rate for the nozzles. The minimum flow rate in gallons per minute (liters per minute) based on the nozzles being used, for the entire boom on the sprayer. **DO NOT** enter the actual flow of your spray application. **FOR EXAMPLE:** If the minimum flow rate for the nozzle you are using is .22 GPM at their minimum recommended pressure and your boom has 20 nozzles, enter 4.4 as the MIN FLOW value (.22 x 20 = 4.4). The system **WILL NOT** apply at a rate lower than this value when spraying in AUTO. This value should be checked/ changed for each different nozzle that you use.

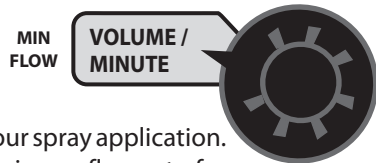

**APPLICATION NOTE:** Over-application may occur with MIN FLOW set if ground speed is too slow.

**FLOW CAL:** This position is used to calibrate the flowmeter for accurate liquid measurement.

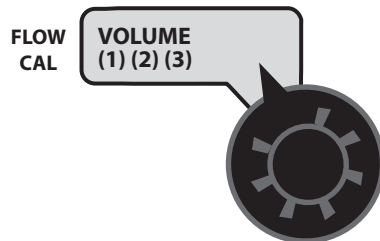

Your Micro-Trak flowmeter has been tested at the factory and assigned a "FLOW CAL" value to make it operate properly with the MT-3405F™ II console. This number is stamped on the metal tag attached to the flowmeter. See **Illustration 13**. This is a starting point only. If your spray solution has a specific gravity or viscosity that is different than water, flowmeter calibration should be done for the specific solution (Please refer to **Fine-Tuning Flowmeter Calibration in Appendix C on page 45.**)

**Illustration 13**

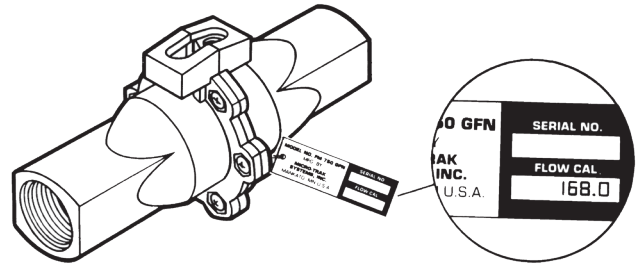

**CAUTION:** If spray lines are pressurized, nozzles may spray during WIDTH calibration (below).

**WIDTH:** Enter the effective working width, in inches (meters) for the boom section currently shown on the display. It is simplest to start with all booms ON and then turn each boom OFF, from left to right, after calibrating the width. Note that the system must be in RUN (not HOLD) to display boom numbers. Repeat this procedure for each boom section. Enter a value of "0" (.000) for any unused boom sections.

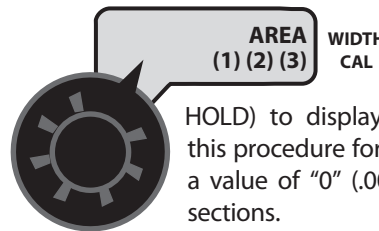

Your "working" width per boom section will be the number of nozzles on the boom section times the nozzle spacing in inches (mm). For example, if you have 7 nozzles spaced at 20 inches, the working width of the boom section is 140 inches.

# Calibration (cont)

## Entering Calibration Values (cont)

**SPEED CAL:** This position is used to calibrate the speed sensor for accurate speed and distance measurement. When this position is selected, the display will show the SPEED CAL value along with "CAL" on the display. See *Illustration 14*. In English units, the SPEED CAL number is displayed in inches, in metric it is displayed in centimeters.

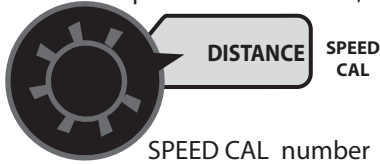

**INLINE/BYPASS:** The display will show InLinE or bYPASS. Use the "+" or "-" buttons to toggle to desired selection. Inline is used when the servo is in the line going out to the booms; Bypass is used when the servo is in a return line. **NOTE: if used on a Micro-Trak NH3 system, it must be set to Bypass.**

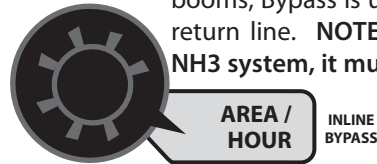

**SPEED CAL FOR RADAR OR GPS SPEED SENSORS:** See the following table for SPEED CAL numbers to enter for various radar models or GPS speed sensors. To fine tune the SPEED CAL number, see Appendix B on page 44.

*Illustration 14*

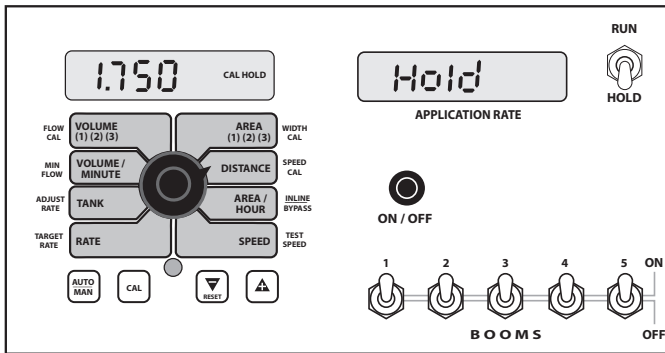

## Radar or GPS Speed Sensor Calibration

Radars	English Cal # in.	Metric Cal # in.	Hz/MPH
Vansco	.150	.38	58.90
Raven	.148	.38	59.80
Magnavox	.154	.39	57.40
Dickey-john (NOTE: Dickey-john radars may be factory calibrated for any of these four settings).	.149	.38	58.94
	.199	.51	44.21
	.319	.81	27.64
	.518	1.32	17.034
<b>GPS Speed</b>			
Astro II & 5	.189	.48	46.56
SkyTrak (Std)	.150	.38	58.94
SkyTrak (MT)	.910	2.31	9.82
Dickey-john	.210	.53	42.00
John Deere (In-cab speed signal)	.197	.50	44.70

## Calibration (cont)

### Determining the SPEED CAL

For the console to calculate the correct speed and measure distance accurately, the circumference of the sensor-equipped wheel must be entered. Determine the circumference of the sensor-mounted wheel to the nearest tenth of an inch (tenth of a centimeter) with the following method:

#### METHOD

Mark the tire with a piece of chalk and measure the distance traveled on the ground for one complete revolution. See Illustration. For improved accuracy, it is recommended that you perform this function in field conditions, measure several revolutions, and take the average.

Divide the measured revolution by the number of magnets installed to get your starting SPEED CAL calibration value. Once calibration of the system is complete, this number should be fine-tuned for optimum accuracy.

*For fine-tuning the SPEED CAL value, see Appendix B on page 44.*

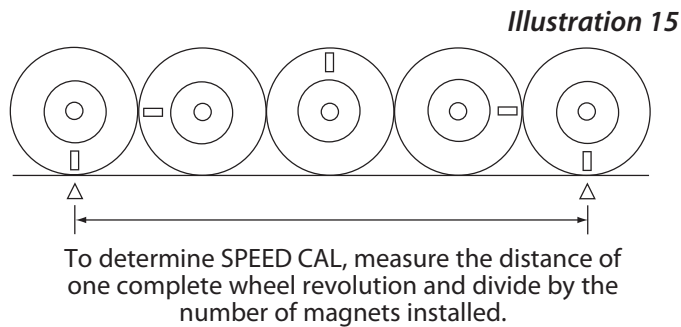

## Drive Shaft Speed Sensor Calibration

**NOTE:** If you have mounted the magnetic speed sensor on a wheel, skip this step and go on to Fine Tuning Speed/Distance Calibration Values.

Because of the difference in wheel-to-drive shaft ratios, it is difficult to determine a calibration value for installation on a drive shaft by measuring a wheel. You must start with an estimated calibration value and then fine-tune the calibration.

Any number between 10 and 15 (255 mm to 380 mm) is a good starting value.

**NOTE:** For fine-tuning the SPEED CAL value, see Appendix B on page 44.

**TEST SPEED:** Test speed is a built-in ground speed simulator that is used in performing pre-field checks. When a typical operating speed is entered, the MT-3405F II will respond as if you were actually driving that speed. It allows you to simulate your spraying application with water, while remaining stationary, to make certain that all of the

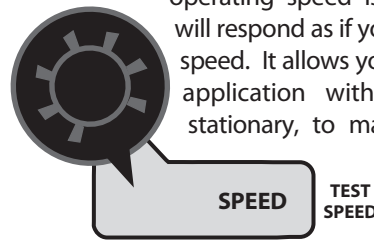

equipment is operating properly and that your sprayer can actually perform the intended

application. Test speed will not accumulate Distance or Area measurements. (The CAL indicator flashes to remind the user that TEST SPEED mode is active.) TEST SPEED is cancelled by exiting CAL.

**EXITING CALIBRATION:** Upon completion of the calibration process, exit calibration by pressing and holding the CAL button until the RED warning light turns off (one second). Basic calibration is now complete. BEFORE beginning application, confirm that the system is set up to do the job that you want it to. Please refer to Pre-Field System Checkout to confirm calibration settings, nozzle selection and overall system performance. **NOTE:** You must exit CAL to save any changes.

## Factory-Loaded Calibration Values

Calibration Factor	Measurements Effected	Default Values	
		English	Metric
TARGET RATE	Application Rate in Auto	10.00 gallons/acre	100.00 liters/hectare
ADJUST RATE	Amount of increase or decrease per +/- press (in auto)	1.00 gallons/acre	10.00 liters/hectare
WIDTH BOOMS 1-3*	Area, Application Rate	240 inches	6.000 meters
SPEED CAL	Distance, Area, App. Rate, Area/Hour	0.189 inches	4.44 centimeters
MINimum FLOW	App. Rate, Lowest Allowable Flow Rate	0.0 gallons/minute	0.0 liters/minutes
FLOW CALibration	Flow/App. Rats, Volume	145.0 pulses/gallon	145.0 pulses/gallon
INLINE/BYPASS	Application Rate	Bypass	Bypass
TEST SPEED	none	0.00	0.00

\* BOOMS 4 AND 5 ARE SET TO 0.

# “Special” Calibration

The “Special” calibration mode is used to set up system parameters that rarely need to be changed or adjusted. To enter Special Cal, put the system in HOLD, turn the console OFF, press and hold both the AUTO/MAN button and CAL button while turning console ON. The console will display SPEC for 2 seconds to show that the console is in the Special Calibration mode. Release the AUTO/MAN and CAL buttons.

The CAL icon and Warn LED will turn on. The desired Special Calibration parameter(s) can then be accessed with the rotary switch per the illustration below. To exit Special Calibration, press and hold the CAL button for 2 seconds. The console will store any changes and revert to normal operation.

**NOTE: you must exit Special Calibration to save changes.**

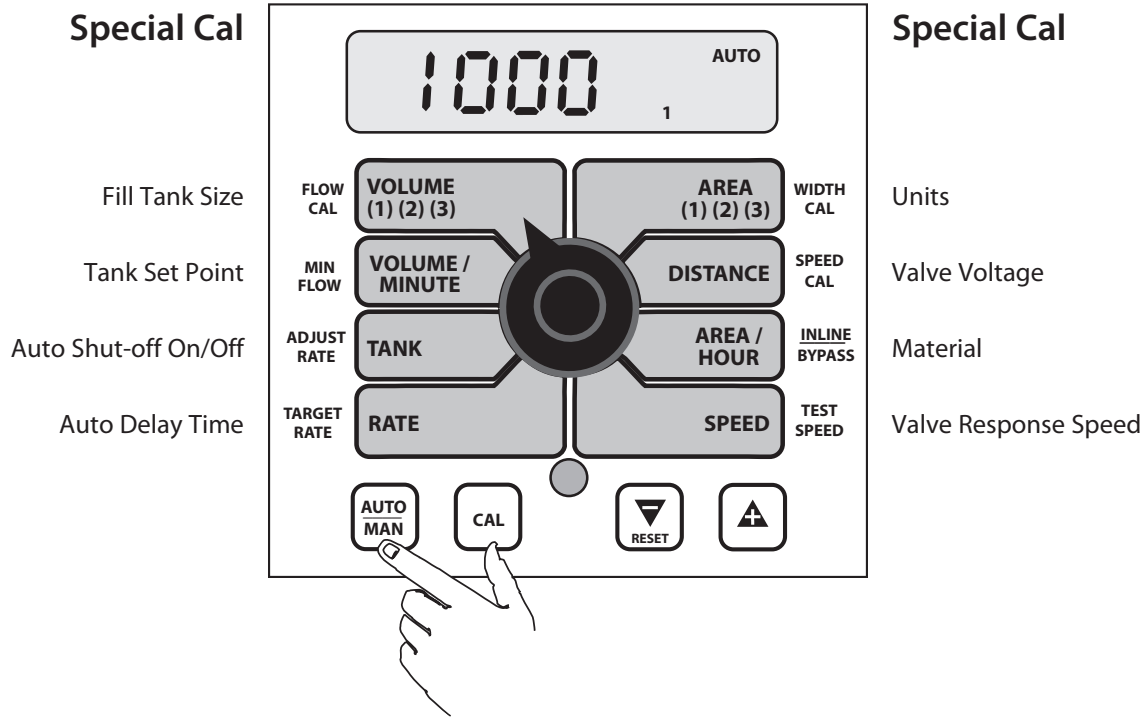

**NOTE: The following table describes the “Special” Cal parameters and shows the factory settings. More detailed descriptions follow the table.**

Parameter	Description	Factory Setting
Units	System of Units EnG (English) or mEt (Metric) / TurF (Turf)	EnG (English)
Valve Voltage	Servo Valve Drive Voltage (8/12)	12
Material	Choose Liquid (H2O) or Anhydrous (NH3)	H2O
Valve Response Speed	Set Valve Response (-4 to 3)	-1
Fill Tank Size	Size (volume) of Full Tank (Off or 1-65,535)	Off
Tank (Low) Set Point	Sets Alarm Set Point if using TANK Function (Off or 1-65,535)	Off
Auto Shut-off	Runs Servo Toward Minimum when in Hold (On/Off)	Off
Auto Delay Time	Delay Servo Response when going from Hold to Run (Off to 4 sec.) Allows slow shutoff valves enough time to open before adjusting servo	1

# “Special” Calibration (cont)

## Entering “Special” Calibration Values

**UNITS:** Choose the system of units desired. Turf units are the same as English units except Area is in thousands of square feet. Use the “+” and “-” buttons to choose between EnG (American English Units), MEt (Metric) and TurF (Turf units).

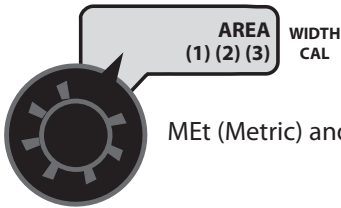

**FILL TANK SIZE:** If using the Tank feature, this setting can be used to enter the volume of the tank. Use the “+” and “-” buttons to choose OFF or any value from 1-65,535. Then when the tank is filled, the tank counter can be reset to full by simply turning the rotary switch to the TANK position and pressing the “+” button. Depending on the “UNITS” setting, the TANK SIZE units will be either gallons or liters. If “material” is set to NH3, the Tank Size will be in lbs. or kg. Anhydrous Ammonia (NH3).

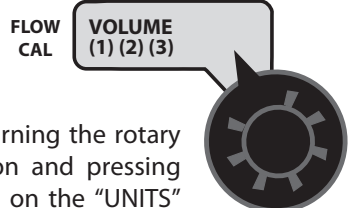

**VALVE VOLTAGE:** Selects the operating voltage for the servo valve. Factory setting is 12 volts. Use the “+” and “-” buttons to toggle between 8 and 12 on display. **NOTE: if using an old style Micro-Trak servo valve, (See Illustration below), set to 8 volts.**



**TANK ALARM SET POINT:** Use the “+” and “-” buttons to set the desired value. This value sets the level at which the Warning LED starts flashing and the word “FILL” flashes on the display. Range is OFF or 1-65,535. When the tank value drops below the set point, the alarms will notify the user that the tank level is low.

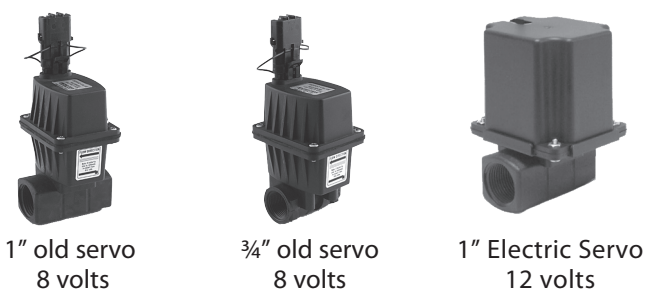

**AUTO SHUTOFF ON/OFF:** When Auto Shutoff is enabled (ON) the servo will run toward minimum flow for 4 seconds any time the system is put in HOLD or all booms are turned off, or if in AUTO mode and speed goes to zero. This feature is normally used only in Dry Application systems where the HOLD condition must stop a hydraulic auger or conveyor belt.

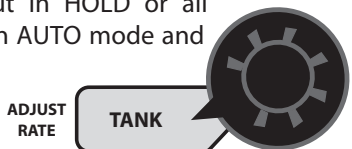

**MATERIAL:** Use “+” and “-” buttons to select between liquid (H2O displayed) or anhydrous ammonia (NH3 displayed). If in NH3 mode, rates will be displayed in pounds (kg) actual N and totals will be displayed in pounds (kg) anhydrous ammonia (NH3). **NOTE: if NH3 is selected, see Appendix F for NH3 specific instructions.**

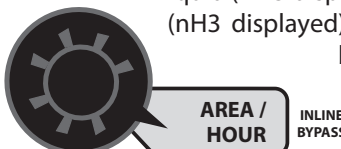

**AUTO DELAY TIME:** Typically used when using relatively slow ball valves for boom shut-off, this feature delays adjustment of the servo valve until the boom valves are open. Use “+” and “-” buttons to set from zero (OFF) to 4 seconds.

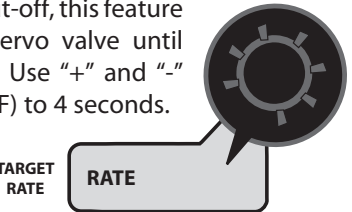

**VALVE RESPONSE SPEED:** Allows adjustment of response to “tune” the system for use with very fast or slow valves. For example, if using a ball valve that takes several seconds to open or close in manual mode, and the system responds sluggishly, use the “+” button to adjust the valve response number to 1, 2, or 3. The range of adjustment is -4 to 3, factory setting is -1. **NOTE: Exercise caution when increasing the valve response speed. If using a relatively fast valve (1-3 seconds open-to-close), the system may become unstable with higher valve response speed numbers entered.**

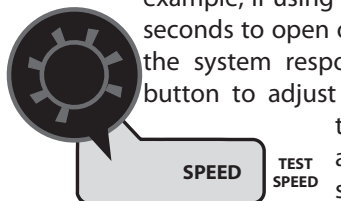

To exit “Special” Calibration, press and hold the CAL button for 2 seconds. The console will store any changes and revert to normal operation.

**NOTE: you must exit “Special” Calibration to save changes.**

# Operation

## General

Make sure your system is properly calibrated before beginning to apply product. We also recommend completion of the Pre-Field System Checkout described on pages 39-40 prior to beginning any field operations.

Press the ON/OFF button to turn the console on. After displaying the hours of operation and software version, the console will start normal operating mode.

The MT-3405F™ II can be operated in Manual (MAN) or Automatic (AUTO) mode. In either mode, the right-hand display will always show the Application Rate (except when in HOLD or when displaying error messages, see Troubleshooting section starting on page 33). The left hand display will show data as selected by the rotary switch.

## Manual Operation

The manual mode is used when the operator wants to manually control the servo valve using the "+" and "-" keys, and thus the application rate. The application rate (gal/acre or liter/hectare) will vary depending on ground speed. Use the AUTO/MAN button to select MANUAL mode ("MAN" icon will be displayed).

**IN HOLD:** If the console is in HOLD, or if all Boom Valves are OFF, the "+" and "-" buttons will not control the servo valve unless the rotary switch is in the VOLUME/MINUTE position. In that position only, the servo valve can be adjusted without any boom valves on. This can be useful for system pressure tests, etc.

## Automatic Operation

When the Automatic mode is selected, the console will control the servo valve to maintain the desired application rate (GPA/LPH) when the vehicle speed changes or when booms are turned on or off. Press the AUTO/MAN button to select AUTOMATIC mode; the AUTO icon will appear in the display.

To operate the system in AUTOMATIC mode, turn on the desired booms, toggle the RUN/HOLD switch to RUN, and drive. **IMPORTANT NOTE:** In AUTO mode, when no speed signal is available, the system automatically turns all booms off. "no SPEED" will flash in the right-hand display until the vehicle starts moving, then the console will turn the booms on and the Application Rate will be displayed in the right-hand display. The system will automatically adjust the servo valve to maintain the calibrated TARGET RATE (GPA/LPH).

**ON-THE-GO "DELTA" RATE ADJUSTMENTS (ADJUST RATE)** To adjust the target application rate on-the-go, each time the "+" or "-" buttons are pressed, the TARGET RATE will be increased or decreased by the amount of the ADJUST RATE which was entered in calibration. Example: calibrated

Turn rotary dial to display desired readout.

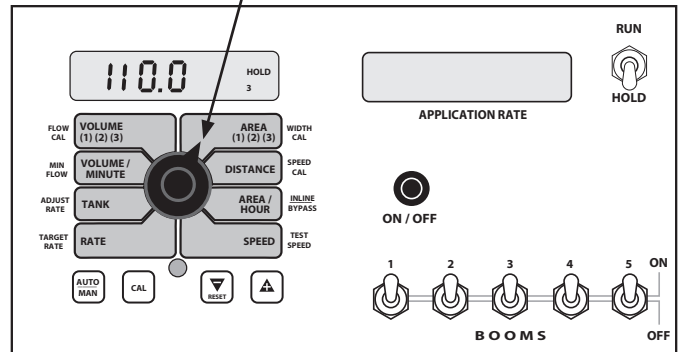

**IN RUN, WITH SPEED SIGNAL:** If the system is in RUN, with at least one boom valve ON and there is a speed signal, the "+" and "-" buttons can be used to adjust the servo valve with the rotary switch in any position except TANK, VOLUME, and AREA and the application rate can be monitored on the right-hand display.

**IN RUN, NO SPEED SIGNAL:** If there is no speed signal, "no SPEED" will flash in the right-hand display and the Application Rate will be invalid. The "+" and "-" buttons will adjust the servo valve if the rotary switch is in the VOLUME/MINUTE position, and the flow rate (GPM or LPM) can be monitored.

TARGET RATE = 10.0 GPA and ADJUST RATE = 1.0 GPA, pressing the "+" key once will increase the target rate from 10.0 to 11.0. The rate display will momentarily show the new target rate of 11.0 and then show the actual application rate. Pressing the "-" key once will decrease the target from 11.0 to 10.0. **NOTE:** When you "DELTA" the target rate, the display will momentarily show you the new target rate and then resume showing the actual application rate. The new target rate is maintained until further adjustments are made using the "DELTA" feature or calibration changes occur, or if the unit is turned off. **Important:** to use the DELTA feature, the console must be in AUTOMATIC mode and the rotary switch can be in any position except TANK, VOLUME, or AREA.

**IN HOLD:** If the system is in AUTO mode and in HOLD or all booms are off, the "+" and "-" buttons will adjust the TARGET RATE with the rotary switch in any position except TANK, VOLUME or AREA; **CAUTION:** we recommend that the rotary switch is in the RATE position, because that is the only position where the new TARGET RATE is displayed while in HOLD. In RATE position, the left-hand display will momentarily display the new TARGET RATE, then will revert to .00, because all the boom valves are off so there is no product being applied.

## Operation (cont)

### Automatic Operation (cont)

#### USING THE TANK COUNTER

With the rotary switch in the TANK position, the left-hand display shows the amount remaining in the tank. If a FILL TANK SIZE (tank full) number has been entered in Special Calibration, the "AUTO FILL" feature is active; this feature allows the TANK counter to be quickly reset to a full tank amount by simply pressing the "+" button with the rotary switch in the TANK position. The "-" button can be used to reduce the tank counter, but any press of the "+" will set the counter to the calibrated FILL TANK SIZE value.

If no TANK VALUE has been entered in calibration, the tank counter can still be used, but the counter must be manually adjusted when filled, by pressing and holding the "+" button until the desired value is reached.

#### WARNING DEVICE

The console is equipped with a RED warning light. The light will automatically turn on and flash when the actual application is plus or minus 10 percent of the calibrated target rate, or if the TANK alarm feature is activated and the tank is below the set point (display will also flash "FILL" message). If the light stays on while in AUTO, refer to the troubleshooting section of this manual. The RED warning light will also be illuminated when calibration mode is active on the console.

#### AUDIBLE ALARM

The Audible Alarm is activated for the following conditions:

- The calculated Tank level is below minimum level (TANK ALARM SET POINT).
- Float switch is continuously active for 15 seconds or more.
- The Application Rate Error is greater than 10% for 3 seconds (continuously) after the Auto Delay and Start Up time have completed and the console is in AUTO, and the Ground Speed is above the Alarm Minimum Speed.

#### EMERGENCY STOP

When in AUTO and in RUN with one or more Booms on and the Speed is greater than zero, if the Flow signal ever stops, the servo will run to fully open. If Flow remains stopped for 5 seconds or more, it will automatically reduce the flow to a minimum (run Servo for 4 seconds). "EStOP" will then display to notify the user of the Emergency Stop. The flow remains off (or reduced) and AUTO control will remain disabled until the system goes into HOLD, power is cycled or CALIBRATE is entered. The Emergency Stop feature helps protect against "chemical spills" or over-application if the Flow signal is lost.

#### TANK ALARM

If a TANK SET POINT (tank low) number has been entered in Special Calibration, the TANK ALARM feature is active. When the tank counter value drops below the TANK SET POINT, the red warning light will flash and "FILL" will flash on the left-hand display. The "FILL" message will flash no matter what position the rotary switch is in. Adjusting the tank value to a value greater than the SET POINT will turn the alarm off.

Turn rotary dial to display desired readout.

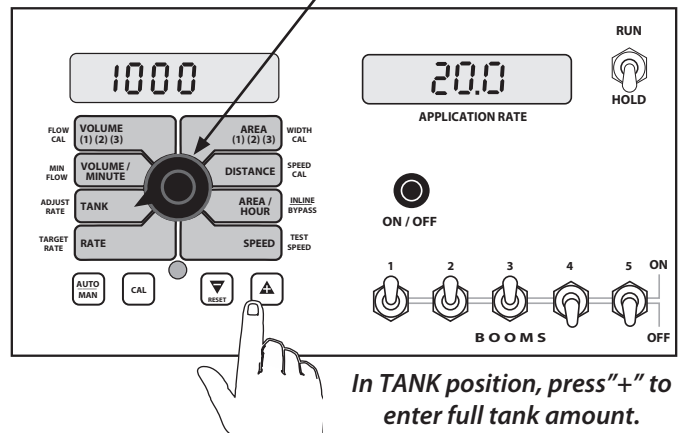

In TANK position, press "+" to enter full tank amount.

### Rotary Switch Positions

(See the NH3 section in the Appendix for NH3 data description.)

#### RATE

Actual number of gallons per acre (liters per hectare) being applied.

#### TANK

Amount (gal or lit) remaining in tank.

#### VOLUME/MINUTE

Flow rate in GPM (LPM).

Three independent pairs of counters. In either the AREA or the VOLUME position, select a pair of counters by pressing the "+" button. The active pair of counters (1,2,3) is indicated by the small numbers in the lower right corner of the left-hand display. DO NOT attempt to select the counter pair

**SEEDS (1) (2) (3):** by using the "-" button because it will reset the selected counter pair to zero. See additional data description below and see RESETTING SYSTEM COUNTERS section.

#### VOLUME (1) (2) (3)

Total gallons (liters) applied since the active counter was last reset to zero.

#### AREA (1) (2) (3)

The acres (hectares) covered since the counter was last reset to zero. The area counters do not accumulate area when the console is in HOLD or if all booms are turned OFF.

#### DISTANCE

The feet (meters) driven since the counter was last reset to zero. This counter does not accumulate when the console is in HOLD. This counter may be reset to zero independent of other system counters.

#### AREA/HOUR

Rate of coverage in acres/hour (hectare/hour).

#### SPEED

Ground speed in miles (kilometers) per hour. IMPORTANT: all booms automatically shut off if system is in "HOLD" or if in AUTO with NO SPEED.

## Operation (cont)

### Resetting System Counters

The AREA, DISTANCE and VOLUME counters maintain a running count during operation regardless of the position of the rotary switch. When any of these counters reach their maximum capacity, or when you want to start a new count, the value may be reset to zero by performing the following routine. Counter pairs may be reset independently of other counter pairs.

1. Turn the booms OFF or put the system in HOLD.
2. Turn the rotary switch to the counter to be reset.
3. To reset distance turn the rotary switch to DISTANCE and simply press and hold the RESET button until the display reads zero. The display will show the word CLEAR during this process, and will show 0.0 when reset to zero is complete.
4. To reset the volume and area counters; there are three independent AREA counters, paired with three VOLUME counters. The active pair of counters is indicated by the small numbers in the lower right area of the display (1, 2, or 3) when the rotary switch is in the AREA or VOLUME position. Select the pair of counters you want to use by pressing the "+" button. The small number will increment each time the "+" button is pressed (from 1 to 3, then rolls back to 1). DO NOT attempt to select the counter number by using the "-" button, because that will clear the active pair of counters if held for 1 second. If the "-" button is accidentally pressed, the console will display "CLEAR" to alert the user that the counters will be cleared. If the user continues to hold the "-" button for 1 second "CLEAR" will disappear and be replaced by .0, indicating that the selected pair of counters has been cleared.

### Clearing Counters

When the desired counter number is displayed, press the "-" (RESET) button and "CLEAR" will be displayed. **NOTE: holding the "-" (RESET) button for 1 second will clear both the #3 AREA counter and the #3 VOLUME counter whether the rotary switch is in the AREA or the VOLUME position.** If the "-" button is released before 1 second has elapsed, the counters will not be cleared and the "CLEAR" message will be replaced with the previous total.

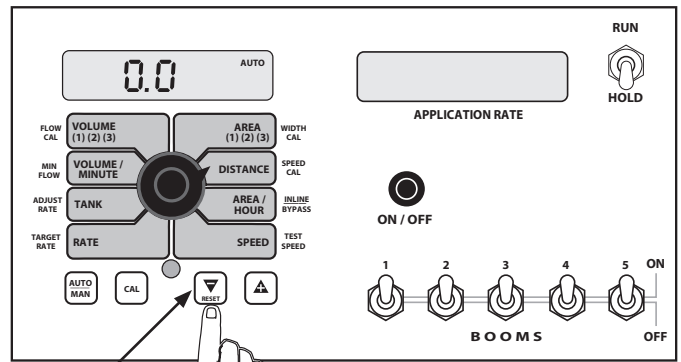

Display indicates counter pair #2 is selected

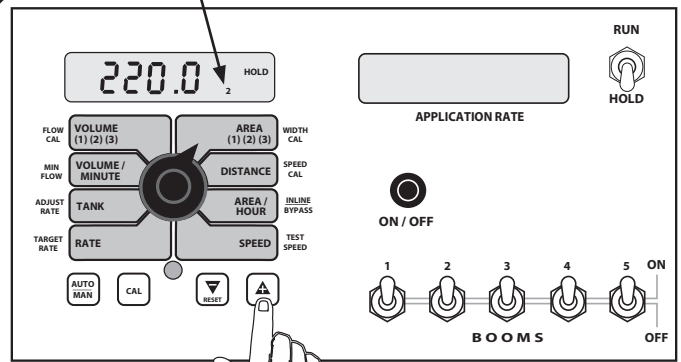

Display indicates counter pair #3 is selected

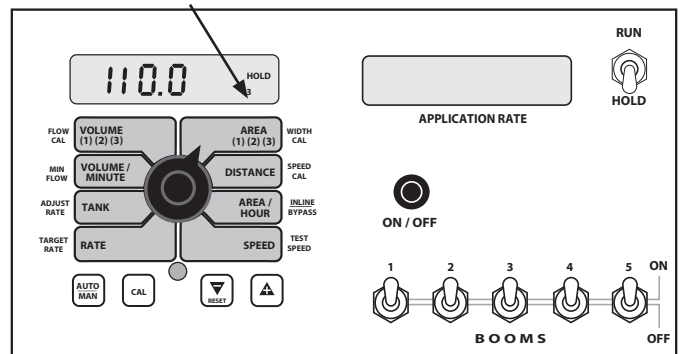

Display indicates counter pair #1 is selected

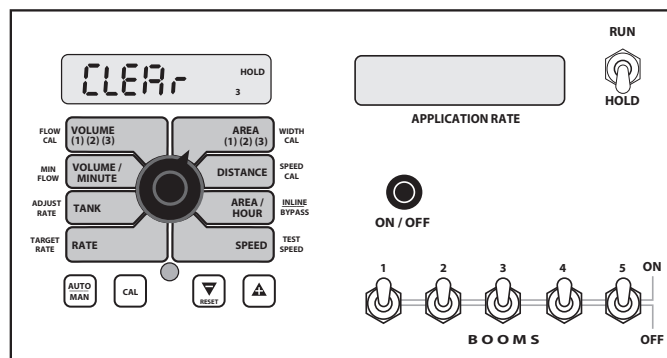
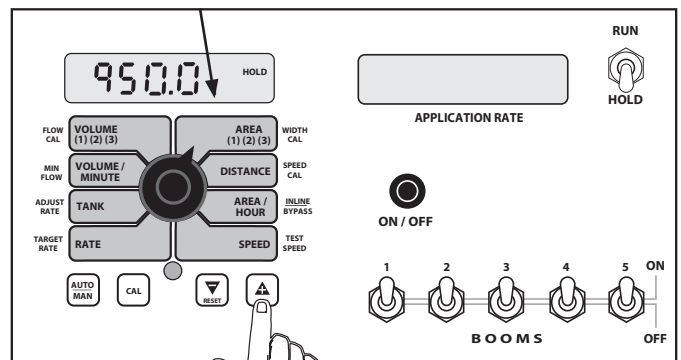

After the "-" (RESET) button has been held for 1 second, the "CLEAR" message will be replaced by ".0", indicating that counter pair #3 has been cleared.





# Troubleshooting

## Messages / Warnings

baD<sup>CAL</sup>

If this message appears, check and verify all calibration values before using the console. It indicates that there may have been a problem with storing calibration values. Cycling power will not clear the bad CAL message, it can only be cleared by entering and exiting calibration mode.

Lo P

Low Power. Check all power and ground connections. After OFF button is pressed and console powers down, this message is briefly displayed.

LoAd

Has loaded Default Cal factors (appears when default calibration factors are loaded by holding CAL and "-" buttons while turning the console on).

no SPEED

Will flash in right-hand display with rotary switch in ANY position if there is no Speed signal regardless of all other conditions. Check speed sensor and connections per Troubleshooting section.

no Flo

Will flash in right-hand display with rotary switch in ANY position if there should be flow (In Run, some booms on, speed greater than 0) but no flow is detected. Check flowmeter and flow harness connections per Troubleshooting section.

no boom

Will flash in left hand display if rotary switch is in Width position, system is in Cal mode and no booms are turned on. Make sure system is in run and a boom switch is turned on, also check Run/Hold switch or sensor and connections.

FILL

Rotary switch in any position, **FILL** will flash if tank level is equal to or less than tank set point. Fill tank and reset TANK counter by setting the rotary switch at the TANK position and pressing the "+" button for one second. Check to make sure TANK set point is properly calibrated.



Warn LED flashes when the Rate error is over 10% or Volume/Minute is below the Minimum, or Tank is less than Tank Set Point. It is on steady when in CAL mode or SPECIAL CAL mode or Test Speed.

SPEC

Special Calibration mode is active. Appears when entering Special Calibration mode (hold AUTO/MAN and CAL buttons while turning console on).

v

The "V" icon shows that a 12v control valve (not 8v) is currently selected. On startup, the "V" is also displayed next to the software version #. (Console hours displayed first.)

EStOP

Had an Emergency Stop. Check flowmeter. Verify there is liquid flow and the tank is not empty.

CLEAR

The message alerts the user that the currently selected counter will be cleared if held for 2 seconds. Also serves as a reminder to use "+" button to select counters.

OFL

Counters (DISTANCE or AREA or VOLUME) have overflowed their maximum. RESET (see page 31) to clear counters and resume counting.

# Troubleshooting (cont)

## General

All MT-3405F™ II consoles, flowmeters and servo valves are tested prior to packaging, so unless there has been damage in shipment you can be confident that everything will be operational when you receive it.

However, if you do encounter a problem that appears to be related to equipment failure, **PLEASE DO NOT OPEN THE CONSOLE**. Your system is protected by a warranty, and Micro-Trak will gladly correct any defect.

Many problems are the result of mistakes in installation or operation. Before returning any parts for service, carefully check your installation and review the operating instructions. For easy-to-follow guidelines, refer to the troubleshooting section which follows.

### CONSOLE APPEARS DEAD

Using your test light, check for 12 volts at the power source. Also check for damaged power cable or reversed terminals. (Console requires 12 volts for proper operation). Check connections of ignition or power switch.

### SPEED IS ALWAYS ZERO OR ERRATIC

Check for properly calibrated wheel circumference.

Review speed sensor installation. Check for proper mounting, alignment and spacing of speed sensor in relationship to magnet assembly. Make sure magnet polarities are alternated. Also check cable for breaks or incomplete connection. *For more suggestions on solutions to speed problems, see Hall-effect sensors and console inputs on pages 35-36.*

### DISTANCE COUNT IS INACCURATE

Wheel circumference was incorrectly measured or entered. Review calibration, re-adjust and test.

### AREA COUNT IS INACCURATE

Implement width or wheel circumference was measured incorrectly or programmed incorrectly. Go back through the original procedures, make changes, and test for acre (hectare) count again. (Make sure no width is entered for unused booms.) Verify accuracy with formula:

$$\begin{aligned} \text{Acres} &= \text{Distance} \times \text{Width in feet} / 43560 \\ \text{Hectares} &= \text{Distance} \times \text{Width in meters} / 10,000 \end{aligned}$$

### NO READOUT OF GALLONS (LITERS), OR GALLONS (LITERS) PER MINUTE

Check to see that the sprayer pump and equipment are operating properly. If liquid is moving through the line, check the flow sensor to be sure it is screwed all the way into the flowmeter.

Check to see that a FLOW CAL number has been entered. Also check cable for breaks or incomplete connection.

If the flowmeter is new or has not been used for a long period of time, the turbine may be sticky. Flushing the system out with water should make the turbine spin freely.

Flow rate may be too low to register a reading, or foreign material may be lodged in the flowmeter.

### BOOMS SHUT-OFF

If you are in AUTO with no speed, the booms will shut-off.

### TOTAL LIQUID USED IS INACCURATE

This may result from an incorrectly-entered "FLOW CAL" value. Check the number stamped on the flowmeter tag, and be sure this is entered in the console's "FLOW CAL" position. If the meter has been used for some time, wear may have changed the Flow Cal value. *See Fine-Tuning Flowmeter Calibration in Appendix C.*

Check the mounting position of the flowmeter. With lower flow rates, the meter should be mounted vertically. Also check to see that the flow sensor is screwed all the way into the flowmeter.

Other causes may be inaccurate sprayer tank markings, a flow rate too low to register, or foreign material lodged in the flowmeter.

### CONSOLE IS ERRATIC IN OPERATION

If you have a two-way radio, it may be mounted too close to the console. Keep all MT-3405F™ II cables away from the radio, its antenna and power cable.

Ignition wires may be causing the console to malfunction. Keep MT-3405F™ II cables away from ignition wires, or install ignition suppressor.

Reroute all cable away from electric solenoids, air conditioning clutches and similar equipment.

Check the VALVE SPEED calibration number in Special Calibration. If the RATE tends to overshoot or oscillate, the VALVE SPEED setting may be too high for the control valve being used; reduce the VALVE SPEED setting by 1 (range is -2 to +3).

### DISPLAYED MEASUREMENTS DO NOT MAKE SENSE

The console may be in the incorrect measurement mode (English or metric). *See page 24 for instructions.*

### DISPLAY READS "OFL"

DISTANCE, AREA, and VOLUME counters read OFL when they have exceeded their maximum count. Reset to zero to resume counting.

### SYSTEM OPERATION (CONTROL) IS SLUGGISH IN AUTOMATIC MODE

Check the VALVE SPEED setting in Special Calibration. If using a slow valve (4 seconds or more, open to close) increase the VALVE SPEED setting.

# Troubleshooting (cont)

## Checking Individual Components

### CONSOLE

The only way to field test a console is to connect it to a harness on a vehicle with a known working console or install it on an E-POP (Electronic Point of Purchase) display stand.

### HARNESS

The harness can be checked using an ohmmeter or continuity tester. The main wiring diagram shows the pin out of all connectors. *See page 9.*

### ELECTRICAL INTERFERENCE

Erratic operation of the system may be the result of electrical interference from ignition wires or inductive loads (electrical clutch, fan, solenoid, etc.). Always try to route wires as far away from suspect areas as possible. If problems occur, you may need to relocate the console and/or wiring harness, or install a noise suppressor.

### POWER

Check power source with the MT-101 tester or a test light. If there is no power, trace cable toward battery looking for breaks. Also check any fuses or circuit breakers that supply power to the console.

### ACCESSORY POWER

The speed, flow and run/hold cables all have an accessory power wire. Check for 12 volts between B (usually white) and C (usually black) of these connectors. If power is not present, make sure the accessory power wire is not open or shorted to ground or to another wire. If this wire has a problem, the console may exhibit erratic behavior or not function at all.

### RUN/HOLD HALL-EFFECT SENSOR (IF USED; REQUIRES ADAPTER CABLE)

Caution: Improper connection or voltage could damage the Hall-Effect sensor. The Hall-effect sensor works similar to a reed switch, but requires power in order to function. This particular type of Hall-effect sensor "closes" when near the south pole of a magnet and is otherwise "open".

- RUN = "OPEN"
- HOLD = "CLOSED"

Ground pin C (black) and connect clean 12 volts to pin B (white) of the Hall-effect sensor cable. Connect the positive lead (red) of an ohmmeter or continuity tester to pin A (red) and the negative lead (black) of the ohmmeter or continuity tester to pin C (black) of the Hall-effect sensor cable.

Holding the tip of the sensor up to the south pole of a magnet should result in a very low resistance (around 300 ohms). Taking the sensor away from the magnet should result in a very high resistance (infinite).

### MAGNETIC HALL-EFFECT SPEED AND FLOW SENSORS

**Caution: Improper connection or voltage could damage the Hall-effect sensor.** The Hall-effect sensor works similar to a reed switch, but requires power in order to function. Also, this particular type of Hall-effect sensor requires alternating magnetic polarities in order to switch. This means that the north pole of a magnet will "open" the Hall effect and the south pole of a magnet will "close" the Hall effect.

Ground pin C (black) and connect clean 12 volts to pin B (white) of the Hall-effect sensor cable. Connect the positive lead (red) of an ohmmeter or continuity tester to pin A (red) and the negative lead (black) of the ohmmeter or continuity tester to pin C of the Hall-effect sensor cable.

Holding the tip of the sensor up to the north pole of a magnet should result in a very high resistance (infinite), while holding the tip of the sensor up to the south pole of a magnet should result in a very low resistance (around 300 ohms).

### VANSCO RADAR SPEED SENSOR

Carefully check your installation and operating instructions. The following are tips for troubleshooting;

1. Disconnect the radar adapter cable from the console harness
2. Check for 12 VDC between pins B and C of the main harness connector (yellow tie). If not present, console or harness may be defective.
3. Using a jumper wire (paper clip bent into a "U"), rapidly short together positions A and C of the main harness speed connector (yellow tie) several times. The console should respond with some speed reading. If not, the console or harness may be defective.
4. Reconnect the radar adapter cable to the main harness speed connection (yellow tie).
5. Disconnect the radar from the radar adapter cable.
6. Check for 12 VDC between pins 1 and 3 of the radar adapter connector. If it is not present but was present in step 2, the radar adapter cable may be defective.
7. Using a jumper wire (paper clip bent into a "U"), rapidly short together positions 2 and 3 of the radar connector (round 4-pin) several times. The console should respond with some speed reading. If not but had a reading in step 3, the radar adapter cable may be defective.
8. If system passes all above tests, the radar may be defective.

# Troubleshooting (cont)

## Checking Console Inputs

If there is no response from any of the following tests, refer to the main wiring diagram to locate the next connector in line toward the console and repeat the test at that connector. If there is a response at that connector, the problem may be in the cable between the two connectors (or the connectors themselves).

### SPEED INPUT

Turn rotary switch to speed position and disconnect the speed sensor (yellow tie) from the main harness. Check for 12 volts between pins B (white) and C (black) of the main harness speed cable (yellow tie). Using a clip lead or other jumper wire (such as a paper clip bent in a "U"), several times rapidly short together pins A (red) and C (black) of the 3-pin connector (See Illustration 16). The console should respond with some speed reading.

### FLOW INPUT

Turn rotary switch to VOLUME/MINUTE and disconnect the flow sensor (green tie) from the main harness. Check for 12 volts between pins B (red) and C (orange) of the main harness flow cable (green tie). Using a clip lead or other jumper wire (paper clip bent in a "U"), several times rapidly short together pins A (brown) and C (orange) of the 3-pin connector. The console should respond with some flow rate reading.

Illustration 16

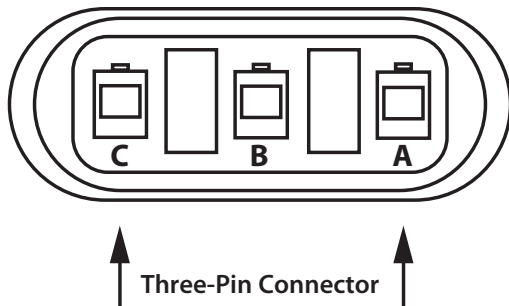

### REMOTE RUN/HOLD INPUT

Grounding the grey run/hold wire should turn on the "HOLD" icon on the console's left display, and display "HOLD" on the console's right display. Disconnecting the grey wire should remove the "HOLD" messages (console run/hold switch in "RUN").

### FLOWMETER

Shaking the Flowmeter end to end should produce a "rattling" sound (shaft end play). Blowing in the meter from either end should spin the turbine freely. If the turbine spins freely but the meter will not register flow with a known working sensor, the turbine may be defective. See *Flowmeter Assembly and cleaning on page 46 and page 60-61 for details.*

### SERVO VALVE CONTROL SIGNAL

With the console turned ON, put the console in MANUAL mode, place the remote Run/Hold switch in the RUN position and turn at least one boom switch to ON. Using a voltmeter or simple test light, check from a good frame ground to each of the servo wires on the main harness connector. You should get 0 volts on each wire. Holding the "+" button should cause one wire to pulse toward 12 volts (light will pulse). Holding the "-" button should cause the other wire to pulse toward 12 volts (light will pulse).

### SERVO VALVE

The best way to test the servo valve is with a known working console. Turn console ON, put the console in MANUAL mode, place the remote Run/Hold in the RUN position, turn the rotary switch to RATE and turn at least one boom switch to ON. With the servo valve connected to the servo valve lead on the main harness, holding the "+" button should close the servo valve and holding the "-" button should open the servo valve NOTE: assuming you are in bypass configuration (provided the console has passed the Servo Valve Control Signal test). The servo valve should operate smoothly in both directions, from fully open to fully closed.

You may also use a 12-volt battery or a 9-volt battery. Connecting the battery to each terminal on the servo valve should cause the servo valve to run in one direction. Reversing the battery connections should cause the servo valve to run the other direction. The servo valve should operate smoothly in both directions, from fully open to fully closed.

### PLUMBING

Proper plumbing is a very important factor in obtaining optimal performance from your MT-3405F™ II system. The chart on the next page will help you determine what area of the plumbing may be causing your problem. At this point, it is assumed that your plumbing basically matches that of the system diagram and that the servo valve and flowmeter are known to be installed correctly and functioning properly. In addition, make certain that you have selected and installed the correct spray tips for the application, speed and spray rate that you intend to maintain. Don't forget the obvious such as leaky fittings and hoses, pinched hoses and plugged or worn nozzles. ***If you need more detail than the chart provides, please refer to Plumbing Guidelines on pages 37-38.***

# Troubleshooting (cont)

## Plumbing Troubleshooting Chart

SYMPTOM	POSSIBLE CAUSE	POSSIBLE SOLUTION
Loses pressure in MAN	Pump Airlock	Clean strainer Larger hoses
Little or no pressure adjustment in MAN	Too much restriction in servo loop	Larger hoses and fittings No sharp bends
Pressure won't go high enough in MAN	Pump starved or too small Too much agitation Throttle, range adjust or pressure relief valves	Larger hoses Reduce agitation Adjust
Pressure, speed and spray rate don't check out according to tip charts	Inaccurate pressure reading Dirty or worn tips	Use a different gauge and check each boom Clean or replace
Pressure always goes too high in AUTO	Minimum flow rate too high Inline/bypass setting	Re-calibrate Set appropriately
Pressure fluctuates greatly in AUTO	Sagging or kinked hoses Throttle valve too far closed Pump starved or too small  Valve response speed too high ("Special" Calibration)	Support or replace hoses Adjust throttle and range valves Larger hoses Larger pump Clean strainer  Lower valve response setting

## Plumbing Guidelines

### General

In order for your sprayer to function properly, it must be correctly plumbed. The system diagrams (*on pages 10 and 12*) show the plumbing configuration that works best with the MT-3405F™ II Sprayer Controller. This section will explain the purpose of each component, list some problems it can cause and recommend some possible solutions to those problems.

A word about pressure drops: All hose, valves and fittings (especially elbows) cause undesirable pressure losses. Keep hoses as large as practical. Don't use longer hoses than necessary. Avoid bends whenever possible. Use as few fittings as possible. Use full port valves or the next larger size valve. Long hoses should be supported to avoid sagging and kinking. Many spray tip manufacturers have charts showing pressure drop for various fittings and hose sizes.

Now let's break the system diagram into five sections and cover each one separately. The five sections are the pump inlet line, the agitation line, the flowmeter (boom) line, the servo line and the pump itself.

### PUMP INLET

The hose connecting the tank to the pump should be at least as large as the pump inlet port. In most cases 1 1/4" is a good size. The valve in this line is for complete tank shut-off only and should always be fully open during operation. If this hose is too small or the valve is partially closed, you may not be able to reach your high end goals and pump damage could occur.

### AGITATION

The size of the agitation line is dependent upon the amount of agitation required which is determined by the size of the tank and the type of chemical being used. In most cases a 1" hose is large enough.

### SERVO

On the system diagram, the hose between tee "B" and the servo can usually be 3/4" but 1" will also work. The hose between the servo and tee "C" should be at least as large as the servo. If these lines are too small, you may experience little or no pressure adjustment.

### FLOWMETER

The line feeding the flowmeter and the boom shut-off valves should be at least as large as the flowmeter. The size of lines going from the shut-off valves to each boom section depends on the flow rate of each boom.

# Plumbing Guidelines (cont)

## General (cont)

### PUMP

The pump must have enough capacity to satisfy the agitation, servo and flowmeter sections of the plumbing. To determine if your pump is large enough you must add up the gallons per minute of all three sections. The following example will take you through the steps involved.

#### EXAMPLE

Let's say our example sprayer has a 300-gallon tank with a Spraying Systems 6290 SC-8 Jet Agitator. The agitator uses 10.2 GPM at 40 PSI.

The sprayer has a 40', three-section boom. Each section is 160" with four tips at 40" for a total of 12 tips. We plan to put on a 25 GPA at 5 MPH and in some areas of the fields we may want to use the Delta feature and increase our rate to 30 GPA and in other areas decrease to 15 GPA. After checking the tip charts we find that a TK-5 Floodjet has a range of 14.9 to 30 GPA at 5 MPH. According to the charts, to get 30 GPA at 5 MPH with a TK-5, the pressure must be 40 PSI. At 40 PSI a TK-5 will spray 1.0 GPM. So, 12 tips at 1.0 GPM each is a total of 12 GPM.

Now let's add everything together.

Agitation	10.2
Spray tips	12.0
Servo	5.0
	<b>27.2 Total GPM</b>

The above addition shows that the system needs 27.2 GPM at 40 PSI. If we add a 10% margin ( $27.2 \times 1 = 2.72$  and  $27.2 + 2.72 = 29.92$ ), we have about 30 GPM. To be sure we have enough volume, the pump should be able to deliver 30 GPM or more at 40 PSI.

## Valve Purpose and Adjustments

### TANK SHUT-OFF VALVE

The tank shut-off valve is for convenience only. It allows you to work on the plumbing without draining the tank. It should always be fully open during operation.

### AGITATION SHUT-OFF VALVE

The agitation shut-off valve is mostly for convenience. It allows you to work on the plumbing without draining the tank. It should normally be fully open during operation.

### PRESSURE RELIEF VALVE

The pressure relief valve is used to avoid excessive pressure when the booms are turned off. Start with the handle screwed mostly out. Slowly bring pump up to operating RPM (make sure pressure does not go too high). Put the MT-3405F™ II in MAN and turn boom on. Hold adjust switch to "+" for about 30 seconds to fully close servo valve. Turn booms OFF. Now slowly screw handle in until maximum desired pressure is reached. Lock handle in place with locking nut or collar.

**NOTE: Spraying Systems 144H DirectoValve has a maximum pressure rating of 100 PSI (7 bar).**

### RANGE ADJUST VALVE

The range adjust valve is required when the pump is much larger than necessary. When the range valve is opened, some of the liquid will be bypassed around the pump to avoid "overloading" the rest of the system. The setting of the range adjust valve is determined by the throttle valve. **Start with the range valve fully closed and perform the Pre-field System Checkout on pages 39-40.** If the throttle valve needs to be more than two thirds closed, open the Range valve slightly and perform the Pre-field System Checkout again.

### THROTTLE VALVE (Bypass Plumbing)

The throttle valve limits your high end to maximize servo performance. **Start with throttle valve fully open and perform the Pre-field System Checkout on page 39-40.**

#### EXAMPLE

With the throttle fully open and servo fully closed, you may be able to get 50 GPA at 5 MPH when you only want 25 GPA. If you were to simply open the servo you may be able to get down to 25 GPA, but if your speed should drop to 3 MPH, the servo can't open any farther and won't be able to maintain 25 GPA. Therefore, if you leave the servo closed and close the throttle until your high end has dropped from 50 GPA to about 30 GPA, the servo has a greater operating range.

The throttle valve pictured in the system diagram is a needle valve (Spraying Systems Type 12690 or 12795). A ball valve may be used but is more difficult to adjust and keep adjusted. Do not install a pressure regulator or relief as a throttle valve.

If the throttle valve is closed too much, PSI may fluctuate greatly in AUTO.

### RELIEF SOLENOID VALVE

The optional relief solenoid will ensure enough bypass to avoid excessive pressure when the boom valves are turned OFF. **See pages 21-22.**

# Pre-Field System Checkout

## Bypass Servo

Before beginning actual spraying, perform the following "Pre-field" procedure to ensure that your valve settings, nozzle selection and desired speed range will allow the MT-3405F™ II to provide the required application control. This procedure should be repeated for each new nozzle selection and/or application rate. By performing all of the steps listed below, you set up your system to allow the MT-3405F™ II to perform at optimum level. Fill your sprayer tank with clean water. **DO NOT** use chemicals until the entire system is completely checked out and operating properly.

**IMPORTANT NOTE: Most nozzles will maintain a good pattern over a maximum speed range of two to one. (For example, if your maximum speed is 12, your minimum speed shouldn't go below 6.)**

**NOTE: Pre-field System Checkout is a procedure performed while the console is in the CAL mode. The Red WARNING light will be lit during the procedure and "CAL" on the display will be flashing.**

Completely close range adjust valve (if installed), and agitation valve (if installed). Completely open throttle valve (must be installed).

Start vehicle and pump, bring the engine up to normal operating RPM. **DO NOT exceed safe system pressure.**

### ENTER MAXIMUM APPLICATION TEST SPEED INTO CONSOLE

With console in HOLD, enter calibration mode. Push and hold (CAL) button. The CAL icon will appear on display and red light will be on. Turn rotary switch to TEST SPEED position. Use "+" or "-" button to enter maximum application speed. Do not exit calibration mode. CAL will flash on the display indicating TEST SPEED mode.

Select manual "MAN" control mode and turn all booms ON.

Turn rotary switch to APP. RATE position and hold "+" button for approximately 30 seconds to completely close the servo valve (control valve).

**NOTE: Assume servo is plumbed in a bypass line. (Maximum bypass allowed - minimum flow output to booms.)**

**NOTE: "+" must increase and "-" decrease output. If opposite, check Inline/Bypass setting on page 26.**

### CAN'T GET THERE?

If you can't get to the desired application rate, you may need different nozzles, pump, or you may need to make modifications to your plumbing configuration. **Please refer to Troubleshooting Plumbing on page 37.**

Adjust agitation valve for desired agitation. If range valve is installed, adjust range valve until display reads 20% higher than the desired application rate.

Slowly close the throttle valve until the display reads slightly higher (5% to 10%) than the desired application rate. If the throttle valve is more than two-thirds closed, install range valve and perform pre-field again.

- Now is a good time to confirm that GPA, GPM, MPH, WIDTH and PSI all coincide with the nozzle manufacturer's charts. PSI may be slightly higher than indicated by the charts due to pressure drop across the solenoid valves, nozzle diaphragm check valves, nozzle screens, etc.

### ENTER MINIMUM APPLICATION TEST SPEED INTO CONSOLE

Turn rotary switch to TEST SPEED position. Use the "+" or "-" button to enter minimum application speed. Do not exit calibration mode. (Remember, the minimum application speed is not normally less than half of the maximum application speed.)

Turn booms ON (make certain system is in Manual mode), turn rotary switch to APP. RATE position and hold "-" button for approximately 30 seconds to completely open the servo valve (control valve).

**NOTE: Assume servo is plumbed in a bypass line. (Maximum bypass allowed - minimum flow output to booms.) The display should now read less than the desired application rate.**

It is not normally a problem if the application rate goes all the way to zero when holding the "-" button for 30 seconds, as long as it goes back up when the "+" button is held.

### CAN'T GET THERE?

If holding the "-" button does not get the application rate to go below the desired application rate, please refer to Troubleshooting Plumbing.

Go to Pre-Field System checkout continued, Inline and Bypass, on next page.

# Pre-Field System Checkout (Cont)

## Inline Servo

Before beginning actual spraying, perform the following "Pre-field" procedure to ensure that your valve settings, nozzle selection and desired speed range will allow the MT-3405F™ II to provide the required application control. This procedure should be repeated for each new nozzle selection and/or application rate. By performing all of the steps listed below, you set up your system to allow the MT-3405F™ II to perform at optimum level. Fill your sprayer tank with clean water. **DO NOT** use chemicals until the entire system is completely checked out and operating properly.

**IMPORTANT NOTE: Most nozzles will maintain a good pattern over a maximum speed range of two to one. (For example, if your maximum speed is 12, your minimum speed shouldn't go below 6.)**

**NOTE: Pre-field System Checkout is a procedure performed while the console is in the CAL mode. The Red WARNING light will be lit during the procedure and "CAL" on the display will be flashing.**

Completely close range adjust valve (if installed), and agitation valve (if installed).

Start vehicle and pump, bring the engine up to normal operating RPM. **DO NOT exceed safe system pressure.**

### ENTER MAXIMUM APPLICATION TEST SPEED INTO CONSOLE

With console in HOLD, enter calibration mode. Push and hold (CAL) button. The CAL icon will appear on display and red light will be on. Turn rotary switch to TEST SPEED position. Use "+" or "-" button to enter maximum application speed. Do not exit calibration mode. CAL will flash on the display indicating TEST SPEED mode.

Select manual "MAN" control mode and turn all booms ON.

Turn rotary switch to RATE position and hold "+" button for approximately 30 seconds to completely open the servo valve (control valve). **NOTE: "+" must increase and "-" decrease output. If opposite, check Inline/Bypass setting on page 26.**

---

## Inline and Bypass

**ENTER TARGET APPLICATION TEST SPEED INTO CONSOLE:** Turn booms OFF. Turn rotary switch to TEST SPEED position. Use the "+" or "-" button to enter target application speed. Do not exit calibration mode.

Select automatic "AUTO" control mode, turn booms ON and turn rotary switch to APP. RATE position. The console should take control and lock-on to your calibrated target application rate.

- **If you calibrated your ADJUST RATE to zero (.0), disregard the following steps:**

### CAN'T GET THERE?

If you can't get to the desired application rate, you may need different nozzles, pump, or you may need to make modifications to your plumbing configuration. **Please refer to Troubleshooting Plumbing on page 37.**

Adjust agitation valve for desired agitation. If range valve is installed, adjust range valve until display reads 10% higher than the desired application rate.

Now is a good time to confirm that GPA, GPM, MPH, WIDTH and PSI all coincide with the nozzle manufacturer's charts. PSI may be slightly higher than indicated by the charts due to pressure drop across the solenoid valves, nozzle diaphragm check valves, nozzle screens, etc.

### ENTER MINIMUM APPLICATION TEST SPEED INTO CONSOLE

Turn rotary switch to TEST SPEED position. Use the "+" or "-" button to enter minimum application speed. Do not exit calibration mode. **(Remember, the minimum application speed is not normally less than half of the maximum application speed.)**

Turn booms ON (make certain system is in Manual mode), turn rotary switch to APP. RATE position and hold "-" button for approximately 30 seconds to completely close the servo valve (control valve). The display should now read less than the desired application rate.

It is not normally a problem if the application rate goes all the way to zero when holding the "-" button for 30 seconds, as long as it goes back up when the "+" button is held.

### CAN'T GET THERE?

If holding the "-" button does not get the application rate to go below the desired application rate, please refer to Troubleshooting Plumbing.

1. Press the "+" button and release. The display will momentarily show the new target rate (target rate + adjust rate) and then lock on to that rate.
  2. Press the "-" button and release. The display will momentarily show the new target rate (target rate - adjust rate) and then lock on to that rate.
- **If the application rate was correctly displayed during manual "MAN" control mode, but registered too high in automatic "AUTO" control mode, the calibration value for MIN FLOW is set too high.**

At this point, the Pre-Field System Check-Out is complete. TEST SPEED will automatically cancel when you exit the CAL mode or when power to the console is turned OFF.



# Appendices

# Appendix A

## Speed Sensor Mounting Installation

### Implement Wheels

1. Secure magnets mechanically or with epoxy.
2. Rigidly mount sensor mounting bracket to the wheel assembly. Cut or bend "L" bracket as required for proper positioning of sensor.
3. Install sensor, adjust to correct spacing (1/4" to 1/2" or 6 to 13 mm is recommended), and secure with 3/8" locking nuts. *See Illustration at right.*

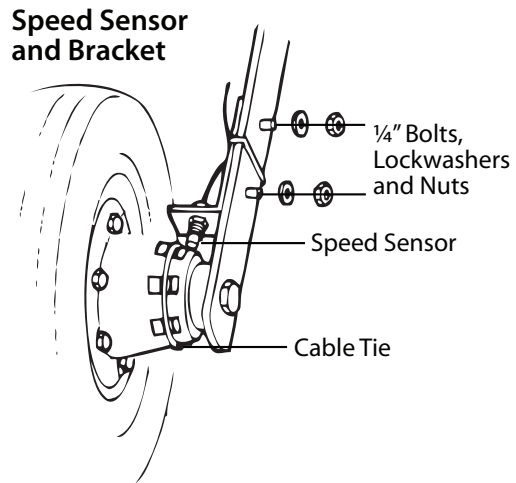

### Front Tractor Wheel

1. Magnets may also be secured with a cable tie and an adhesive such as epoxy.
2. Mount the speed sensor bracket to a part of the wheel assembly that does not change position to the hub when

the wheels are turned. If the "L" bracket provided cannot be bent and mounted to properly position the sensor, make a bracket similar to the one shown at right.

3. Install sensor, adjust to correct spacing (1/4" to 1/2" or 6 to 13 mm is recommended), and secure with 3/8" locking nuts.

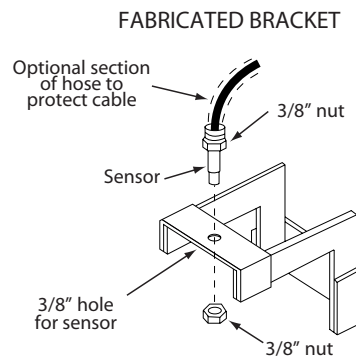
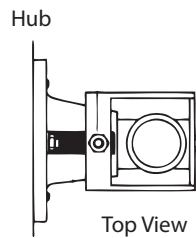
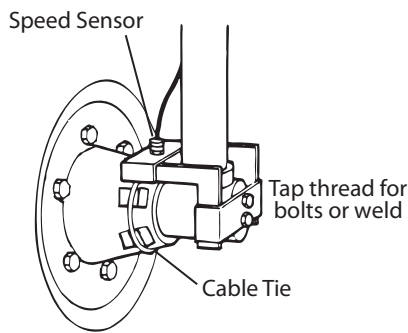

### ATV Wheels

Two mounting examples are illustrated:

1. Using one cable tie (ribbed side toward magnets), secure two magnets to the wheel hub so they are exactly opposite each other. Alternate the magnets' polarities.

2. Cut and bend sensor mounting bracket as needed and rigidly mount.
3. Insert sensor, adjust spacing (1/4" to 1/2" or 6 to 13 mm) and secure with 3/8" locking nuts.

**CAUTION: Make sure valve stem cannot make contact with sensor or bracket.**

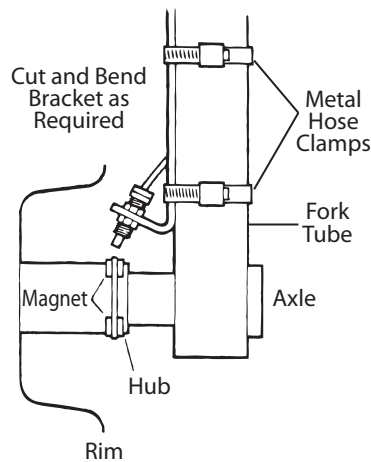
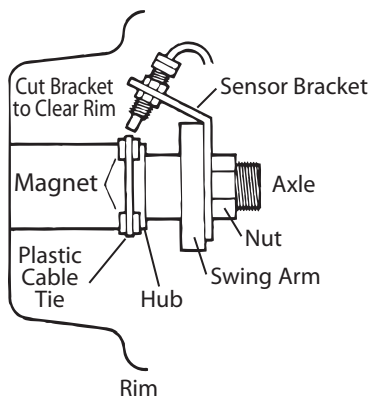

## Appendix A (cont)

### Optional Speed Sensor Mounting on Drive Shaft

**NOTE:** This is an optional method generally used on pickups or custom vehicles. It may also be necessary on any other vehicles where access to the wheels is limited. This installation requires a special calibration procedure, see page 27.

Determine the best location for the magnets on drive shaft according to which is the most practical spot to attach sensor mounting bracket. This position should be no more than 12" (.30 meters) behind the front U-joint. For best results, mount "L" bracket to transmission and mount magnets on drive shaft as close to transmission as possible. This will ensure proper alignment if drive train shifts under heavy loading.

Two magnets are required for proper Hall-effect speed sensor operation. Position them exactly opposite each other (180 degrees apart). The polarity (north and south poles) detected by the Hall-effect speed sensor must alternate as the shaft is turned. The magnets provided by Micro-Trak are marked with a punched dashed line on the SOUTH pole side of the magnet.

- Attach magnets onto drive shaft, one NORTH pole side out and the other SOUTH (dashed) pole side out, by wrapping cable tie around shaft and magnets. Position each magnet so that its longest dimension moves in the direction of rotation. Pull cable tie tight and trim off excess. An adjustable, non-magnetic (stainless steel) band clamp may also be substituted.
- Attach sensor bracket to vehicle transmission with bolts, lockwashers and nuts provided. *See illustration below.* (Use self-tapping screws if bolts are not practical.) Use either the short or long end of the bracket as a base. (Allow enough room between the bracket and the magnets so that when properly spaced, the tip of the sensor will extend 1/4" [7mm] or more beyond the locking nut.)
- Turn one locking nut onto threaded sensor and insert sensor into large hole selected on mounting bracket. Turn on remaining locking nut. Set sensor to proper distance from magnets (1/4" to 1/2", or 6mm to 13mm). When distance is set, tighten nuts to lock sensor in place.
- Secure sensor cable to frame with cable ties. Place first tie as close to sensor assembly as possible.

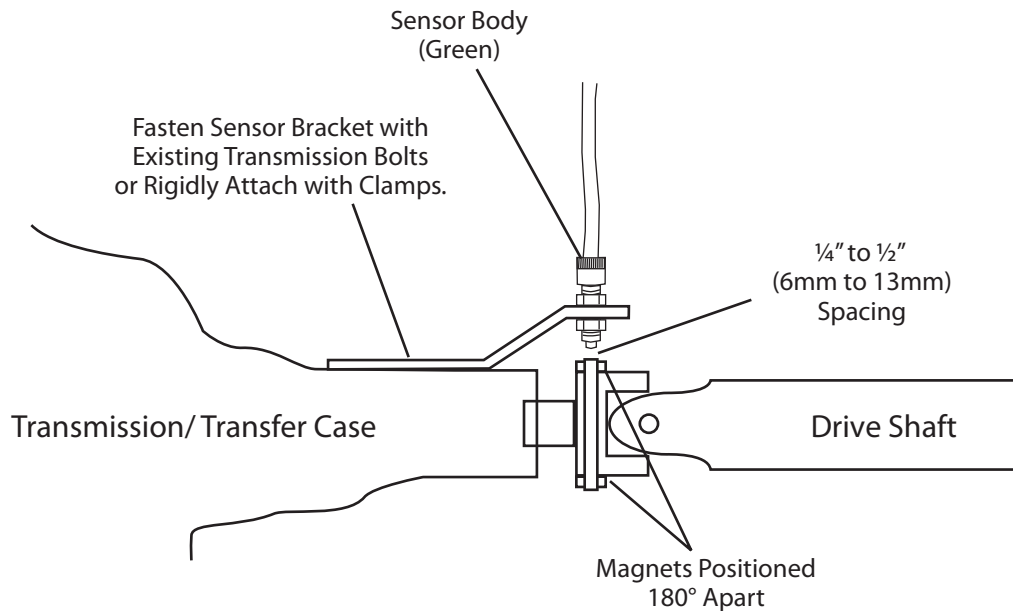

# Appendix B

## Fine Tuning Speed/Distance Calibration Value

(If system is set up for NH3 application, see page 58)

This procedure is used to verify the speed/distance calibration. In order to achieve accurate measurements, each step in this fine tuning procedure should be performed as precisely as possible.

### PREPARATION

- Once the system is fully installed and calibrated, select a straight tract of ground that is similar to your actual field conditions and as level as possible.

**NOTE: Using a course with a different ground surface, such as a hard-surface road, will result in different readings than exact field conditions.**

- Measure a distance of 1000 feet (500 meters). Clearly mark the beginning and end points with flags or something highly visible to the operator.

### PROCEDURE

- With the console turned ON, place the Run/Hold switch in the HOLD position. The HOLD icon will be displayed. Turn the rotary dial to the "DISTANCE" position. Be sure the display shows 0. If not, reset the distance counter by pressing and holding "RESET" until the display returns to 0 (approximately one second). The word CLEAR will be displayed when reset is pressed.
- You are now ready to drive the measured course. Pick a location on the vehicle to use as a marker for starting and stopping the distance counting function (door handle, mirror, step, etc.). You should begin driving the course well ahead of the starting flag and drive past the ending flag, using the Run/Hold switch to start and stop the counting function. It is not recommended to start from a dead stop at the starting flag and stop at the ending flag.
- Place the Run/Hold switch in RUN when the marker on the vehicle passes the starting flag to activate the distance counting function. The console display numbers will increase, adding to the distance total as you drive. Drive the pre-measured course and place the Run/Hold switch in HOLD, when the marker on the vehicle passes the ending flag, to stop the distance counting function. The console display should read "HOLD". **See Illustration to the right.** Stop the vehicle in a level and safe area and continue with this procedure.

- With the rotary dial still at DISTANCE (SPEED CAL), press and hold the "CAL" key for one second. Once the console is in "CAL," CAL and the speed calibration value will be displayed. Momentarily press CAL and the word CAL will begin to flash and the distance travelled will be displayed.
- When the display shows distance ("CAL" is flashing), verify whether the number displayed is the exact distance you drove (within +/- 1 - 2 %). If not, press the "+" or "-" key to adjust the figure to match the distance you actually drove. If the display reads too high, use the "-" key to lower the displayed value. If the display reads too low, use the "+" key to raise the displayed value.
- When the number shown on the display matches (as closely as possible) the actual distance driven, you have arrived at the correct calibration value. If you cannot adjust the displayed distance to exactly match the actual distance driven, adjust the figure as close as possible to the actual distance. You may check the calibration number by momentarily pressing CAL. The word CAL and the SPEED CAL number will appear. Exit "CAL" by pressing "CAL" for one second.

The speed sensor is now calibrated. To verify proper calibration, repeat the procedure a second time. Write down the new speed calibration number and keep it in a safe place. If the calibration values are ever accidentally changed, you can simply re-enter this number.

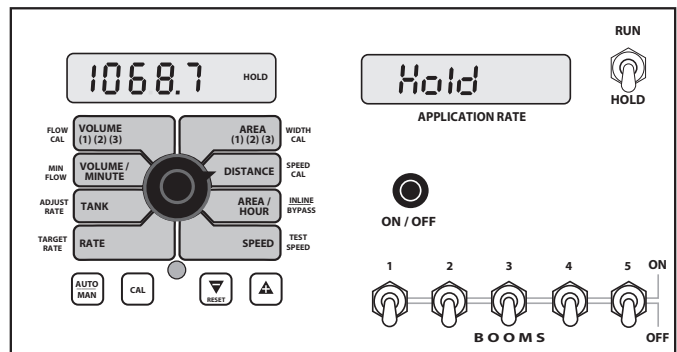

# Appendix C

## Fine Tuning Flowmeter Calibration Value

(If system is set up for NH3 application, see page 57)

This procedure is used to verify and fine-tune the flowmeter calibration. Every flowmeter is calibrated with water at the factory and stamped with a calibration value. Enter that value as a starting point and use this procedure to fine-tune that value for your specific installation and spraying application. This procedure should be repeated each time a new solution is being applied (differing solutions will have a different specific gravities and different flow characteristics) or when the flowmeter installation has been altered.

### PROCEDURE

1. Put enough water in the sprayer tank to perform this test. (Preferably 100 gallons or more. The larger the volume of water used, the more accurate will be the calibration.)
  2. Start sprayer pump and turn on booms. Run enough water to purge all air from lines. Turn off booms but leave pump running.
  3. Turn console rotary selector to the VOLUME position. Select the counter (1-3) that you want to use. Press and hold the RESET button until the display reads 0 (about 2 seconds).
  4. Turn on all booms, turn Run/Hold switch to RUN, and run a known amount of water (preferably 100 gallons or more). \*
  5. Put Run/Hold switch in HOLD position. Compare the console's VOLUME reading with the known amount of water run. If the two amounts are within one or two percent, no fine tuning is required. If the two amounts are more than two or three percent different, continue with the next step.
  6. With the console still in the VOLUME position, enter calibration, hold the CAL button until red warning light comes on; about one second). The display will show the flowmeter calibration value and the CAL icon.
  7. Momentarily press the CAL button. The CAL icon will begin to flash and the total volume will be displayed. *See Illustration to the right.*
  8. When the TOTAL FLOW value is displayed, use the "+" or "-" button to adjust the value to match the amount of water run.
  9. Momentarily press the CAL button. The CAL icon and the flowmeter calibration number will be displayed. You will notice that the flowmeter calibration value has changed. Write down the new flowmeter calibration value. This is your "fine tuned" calibration value, keep it for future reference.
  10. Exit calibration by holding the "CAL" button until the red warning light goes out (about one second).
- \* The most accurate method to measure the volume of water run is to place a container under EVERY nozzle and add together the amount from each nozzle. This assures that 100 percent of the water is collected and that all nozzles are spraying equally. It is important to perform this procedure at a flow rate similar to that which will be used in the field. It is also possible to disconnect the main boom line and run it to a large measuring container but a valve must be installed and properly adjusted to simulate actual field conditions.

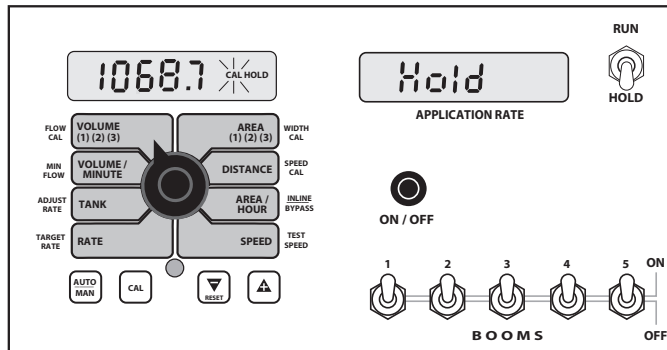

# Appendix D

## Flowmeter Assembly

**IMPORTANT:** Opening the flowmeter will void the Flowmeter Calibration value assigned to your unit. However, you may need to take the flowmeter apart for periodic cleaning or to remove an obstruction.

If you can shake the flowmeter from end-to-end to produce a “rattling” sound (shaft-end play), or if you can blow into the meter from either end and cause the turbine to spin freely, your flowmeter **DOES NOT** need cleaning. If you **CANNOT** hear the “rattling” sound or get the turbine to spin freely, your flowmeter *needs* to be cleaned. *See Illustrations below for reassembly instructions.*

### OPENING THE FLOWMETER

Cut the calibration tag retaining wire. Remove the screws and disassemble the flowmeter. Do not attempt to remove the sleeve bearings from the flowmeter housing.

Use warm water and if necessary, a mild detergent and a soft bristle brush to clean all parts. **Do not use solvents or diesel fuel to clean the flowmeter.** A magnet works well for removing fine metallic particles from the turbine.

Inspect all parts. Check for excessive bearing or shaft wear. The shaft will wear shorter until the turbine drags on the housing. *Illustration 17* shows you what a new shaft looks like. When the shaft is worn to the point of drag, the turbine must be replaced.

On a flat surface, place each housing half on end. Set and spin the turbine in each half. It should spin freely. If it does not spin freely, remove the turbine, wipe the shaft and try again. If it still does not spin freely, the shaft or bearings may have excessive wear. (Service may be necessary.)

### ASSEMBLING THE FLOWMETER

Stainless steel meters use a Teflon gasket. Sealants are normally not required. Plastic meters use an o-ring (Quad-ring). Apply a small amount of silicon grease for lubrication. Gaskets and o-rings may be reused several times but eventually may need replacement.

Place the turbine in the non-sensor housing. Position gasket /o-ring; carefully place sensor housing over turbine. Drop all screws into holes. Hold nuts (and lock washers on stainless meters) in place and finger-tighten screws. Ensure proper placement of gasket/o-ring and evenly tighten all screws. Attach tag.

After assembly, shaking flowmeter end-to-end should produce a “rattling” sound (shaft end play). Blowing into the meter from either end should cause the turbine to spin freely. If the turbine only spins from one direction, install the flowmeter so that the liquid flows in that direction (service may be required).

For maximum accuracy the flowmeter should be mounted in a vertical position. Recalibration is required before field operation.

**Complete Assembly  
FM750 GFN Flowmeter**

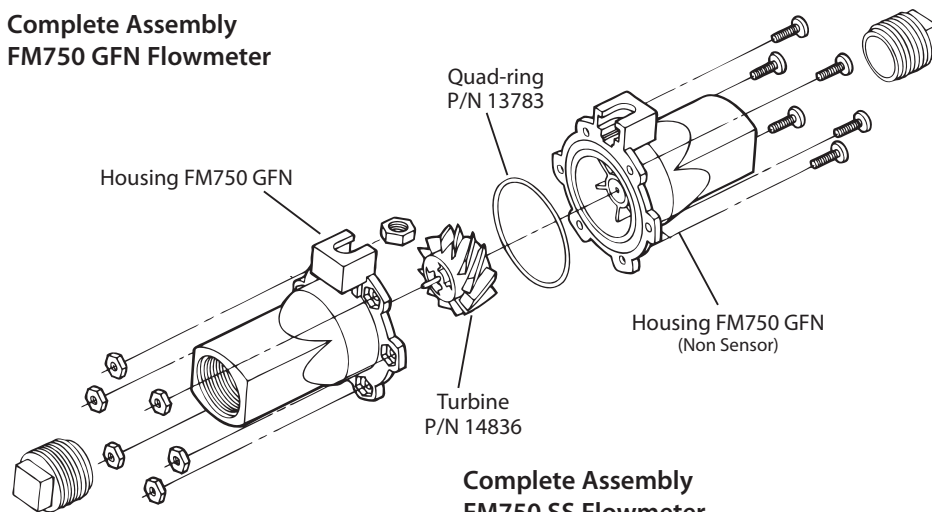

**Illustration 17**

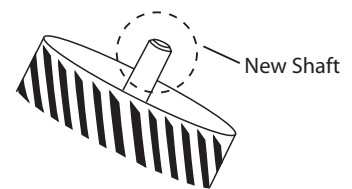

**Complete Assembly  
FM750 SS Flowmeter**

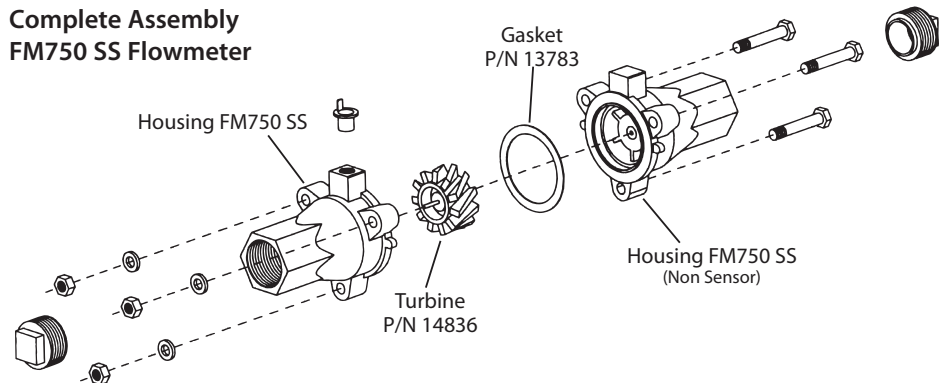

# Appendix E

## Electric Pump Driver (EPD) - 30 Amp Maximum

The Pump Driver Module (EPD) replaces the servo valve. System flow is controlled by regulating the pump speed.

### MODULE INSTALLATION

**NOTE:** The mounting surface must be cleaned so it is free from dirt, moisture and oil residues. Failure to clean the mounting surface may result in the EPD working loose.

Remove the GREEN backing from the Dual-Lock™ fasteners on the bottom of the EPD unit. Position the EPD where wiring will work the best. Extension cables are available. Firmly press the EPD into place. Secure the EPD to the equipment using plastic cable ties to prevent the EPD from coming into contact with moving parts if the Dual-Lock™ fasteners should work loose. If desired, the EPD can be fastened with screws, using the holes in the mounting flanges.

### ELECTRICAL INSTALLATION

This section explains how to hook-up your EPD to a 12-volt power connection, and how to connect your EPD to your controller harness.

The EPD **MUST** be connected to a 12-volt DC negative ground electrical system.

### POWER BATTERY CONNECTION

Locate the power cable, P/N 14499 and route to the battery. In routing cable avoid areas where the cable may be subjected to abrasion or excessive heat. Attach the BLACK wire (ground) to a screw or bolt on the equipment frame. See Illustration to the upper right. Be sure there is a good metal-to-metal contact. Connect the ORANGE wire to the positive battery terminal.

Connect the power to the EPD by plugging the 3-pin W/P tower on the power cable into the 3-pin W/P shroud of the EPD module.

### SIGNAL AND MOTOR CONNECTIONS

Locate the boom wire, P/N 14500. This is a single wire, 12V signal. 12V = ON and 0V = OFF. Plug the 2-pin W/P shroud into the mating connector on the EPD module and plug the quick-disconnect into the mating connector on the BROWN wire (if connecting to a SprayMate system) or the YELLOW wire (if connecting to an MT-3405F or an MT-9000 system) on the controller harness as shown.

**NOTE:** be sure to route cables away from sharp edges, areas of high heat and moving parts. Secure all cables firmly with plastic cable ties.

Locate the servo cable P/N 10450. Connect the 3-pin W/P shroud to the 3-pin W/P tower on the EPD module. Connect the other end of the cable to the mating connector on the controller harness as shown.

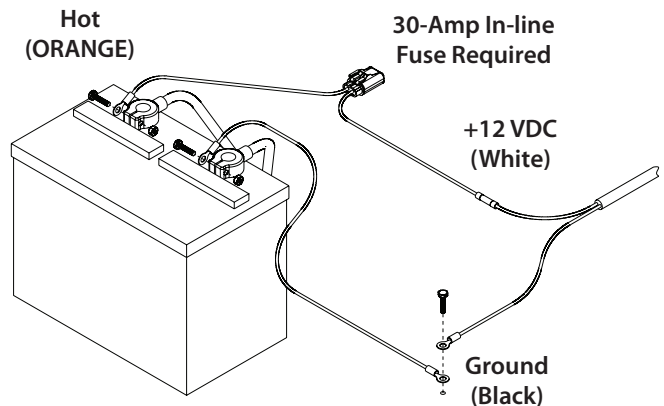

Locate the pump cable P/N 14501. Plug the 2-pin W/P tower into the 2-pin W/P shroud on the EPD module. A mating connector is supplied to connect to the motor, or the connector on the pump cable can be removed and wire-to-wire connection can be made. Insure that the pump is running in the correct direction. If not, simply reverse the wires from the pump to the pump cable.

See next page for applicable diagram.

**NOTE:** MICRO-TRAK CONSOLE MUST BE SET FOR "BYPASS" OPERATION.

### EXTENSION CABLES

If extension cables are required, they should be installed at the Pump Output of the EPD, not the Power Input. Extension cables installed at the Power Input cause too much voltage to be dropped over the length of the cables, and the voltage across the input to the EPD will be too low for proper operation. If the voltage across the input connector of the EPD falls below approximately 10 volts; the processor is disabled and the output will remain where it was before the voltage fell below 10 volts. The EPD must be disconnected from the power supply and reconnected to reset the processor.

### OVER - CURRENT PROTECTION

When an over-current condition is detected, the EPD will shut down for a disable period of approximately 3 seconds. After the disable period is completed, an internal restart is attempted. If the over-current condition is present again, the EPD shuts down. It must be disconnected from the power supply and reconnected to reset the processor.

# Appendix E

## Electric Pump Driver (EPD) System Diagram - 30 Amp Maximum

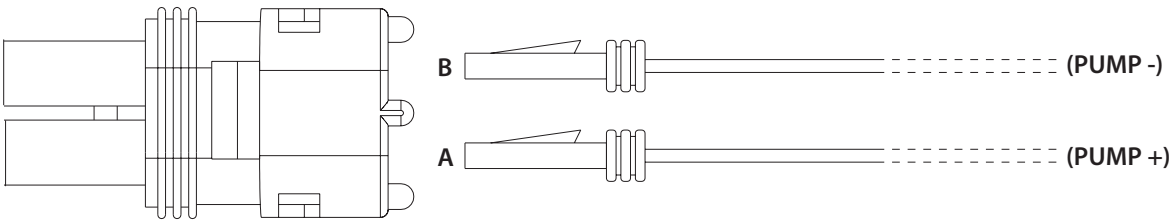
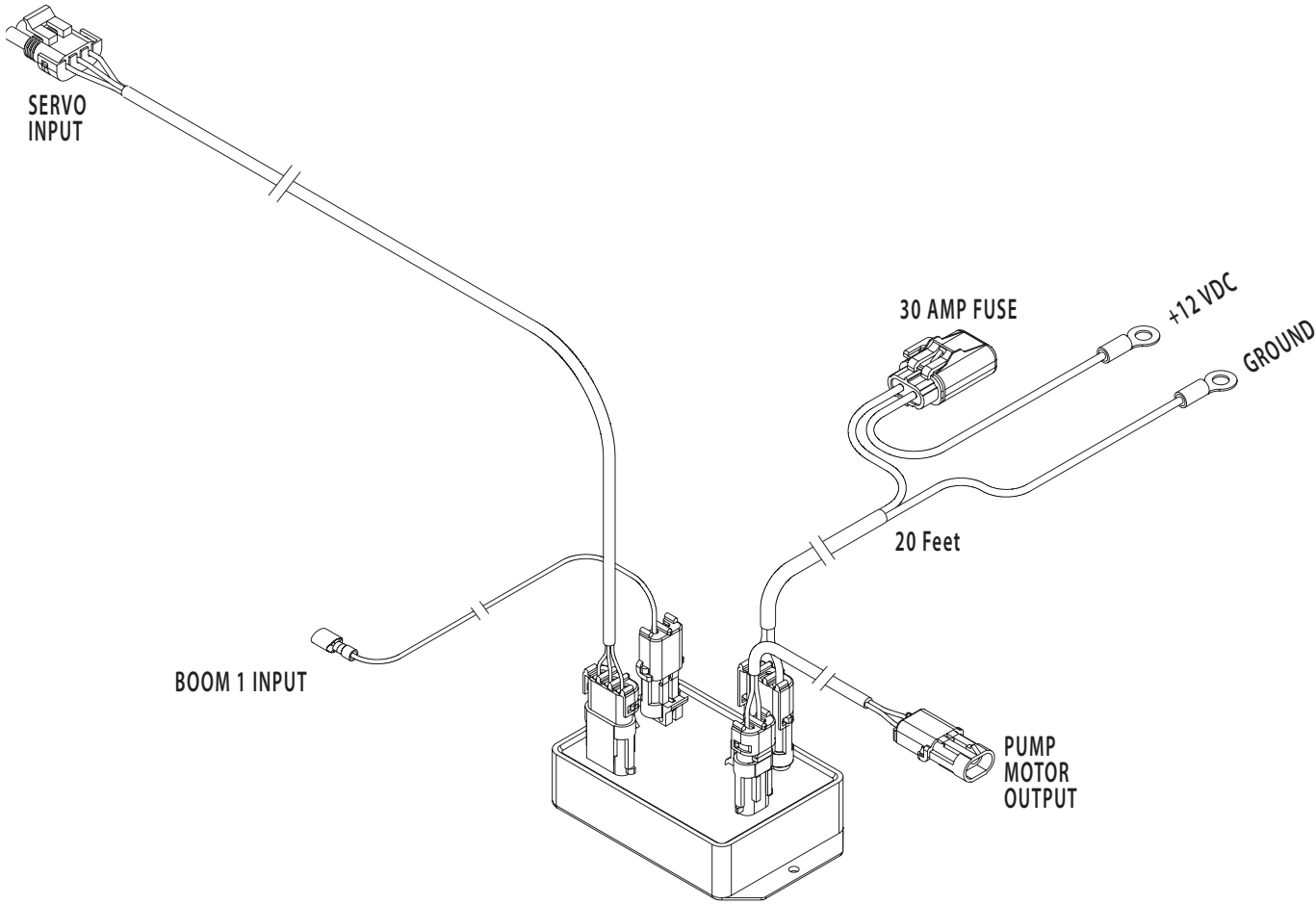

**WARNING:** Do NOT connect the motor leads to the battery or power supply. Non-warranty damage will result if the motor leads are connected to the battery or power supply.



# Appendix E

## Electric Pump Driver (EPD) - 40 Amp Maximum

The Pump Driver Module (EPD) replaces the servo valve. System flow is controlled by regulating the pump speed.

### MODULE INSTALLATION

**NOTE:** The mounting surface must be cleaned so it is free from dirt, moisture and oil residues. Failure to clean the mounting surface may result in the EPD working loose.

Remove the GREEN backing from the Dual-Lock™ fasteners on the bottom of the EPD unit. Position the EPD where wiring will work the best. Extension cables are available. Firmly press the EPD into place. Secure the EPD to the equipment using plastic cable ties to prevent the EPD from coming into contact with moving parts if the Dual-Lock™ fasteners should work loose. If desired, the EPD can be fastened with screws, using the holes in the mounting flanges.

### ELECTRICAL INSTALLATION

This section explains how to hook-up your EPD to a 12-volt power connection, and how to connect your EPD to your controller harness.

The EPD **MUST** be connected to a 12-volt DC negative ground electrical system.

### POWER BATTERY CONNECTION

Locate the power cable, P/N 17871 and route to the battery. In routing cable avoid areas where the cable may be subjected to abrasion or excessive heat. Attach the BLACK wire (ground) to a screw or bolt on the equipment frame. See Illustration to the upper right. Be sure there is a good metal-to-metal contact. Connect the ORANGE wire to the positive battery terminal.

Connect the power to the EPD by plugging the 2-pin M/P tower on the power cable into the 2-pin M/P shroud of the EPD module.

### SIGNAL AND MOTOR CONNECTIONS

Locate the boom wire, P/N 14500. This is a single wire, 12V signal. 12V = ON and 0V = OFF. Plug the 2-pin W/P shroud into the mating connector on the EPD module and plug the quick-disconnect into the mating connector on the BROWN wire (if connecting to a SprayMate system) or the YELLOW wire (if connecting to an MT-3405F or an MT-9000 system) on the controller harness as shown.

**NOTE:** Be sure to route cables away from sharp edges, areas of high heat and moving parts. Secure all cables firmly with plastic cable ties.

Locate the servo cable P/N 10450. Connect the 3-pin W/P shroud to the 3-pin W/P tower on the EPD module. Connect the other end of the cable to the mating connector on the controller harness as shown.

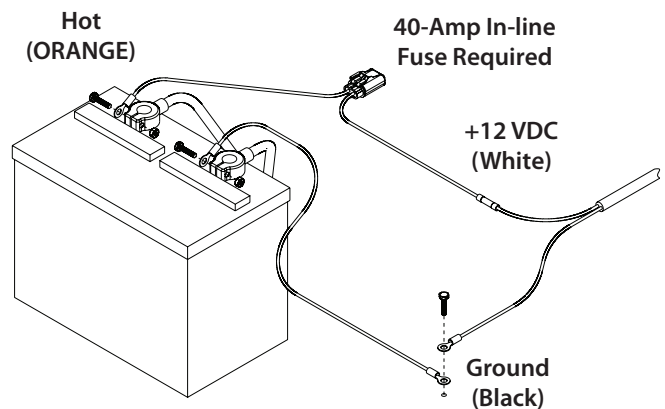

Locate the pump cable P/N 17872. Plug the 2-pin M/P shroud into the 2-pin M/P tower on the EPD module. Insure that the pump is running in the correct direction. If not, simply reverse the wires from the pump to the pump cable.

See next page for applicable diagram.

**NOTE:** MICRO-TRAK CONSOLE MUST BE SET FOR "BYPASS" OPERATION.

### EXTENSION CABLES

If extension cables are required, they should be installed at the Pump Output of the EPD, not the Power Input. Extension cables installed at the Power Input cause too much voltage to be dropped over the length of the cables, and the voltage across the input to the EPD will be too low for proper operation. If the voltage across the input connector of the EPD falls below approximately 10 volts; the processor is disabled and the output will remain where it was before the voltage fell below 10 volts. The EPD must be disconnected from the power supply and reconnected to reset the processor.

### OVER - CURRENT PROTECTION

When an over-current condition is detected, the EPD will shut down for a disable period of approximately 3 seconds. After the disable period is completed, an internal restart is attempted. If the over-current condition is present again, the EPD shuts down. It must be disconnected from the power supply and reconnected to reset the processor.

# Appendix E

## Electric Pump Driver (EPD) System Diagram - 40 Amp Maximum

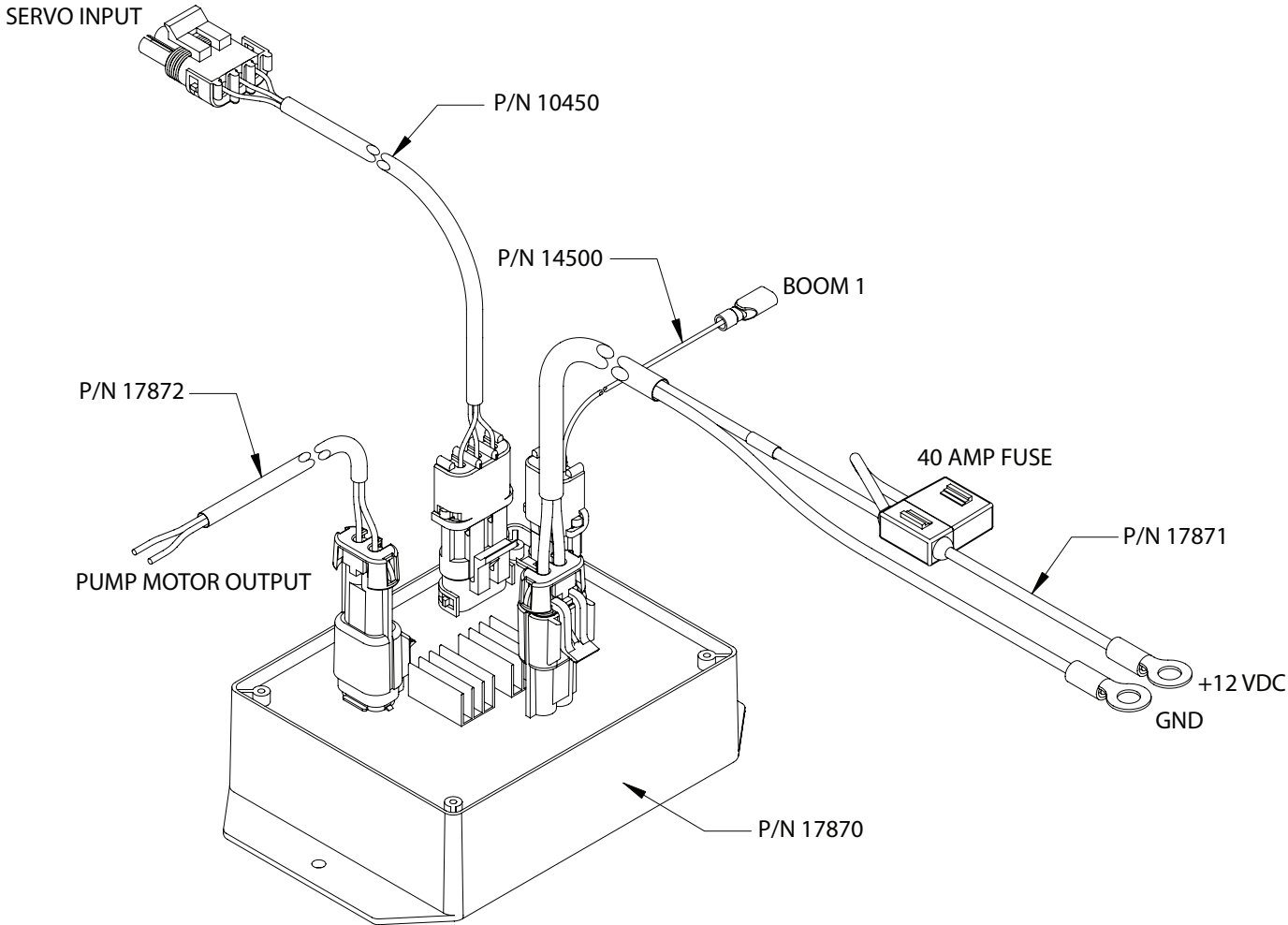

**WARNING:** Do NOT connect the motor leads to the battery or power supply. Non-warranty damage will result if the motor leads are connected to the battery or power supply.

# Appendix F

## NH3 Specific System Diagram

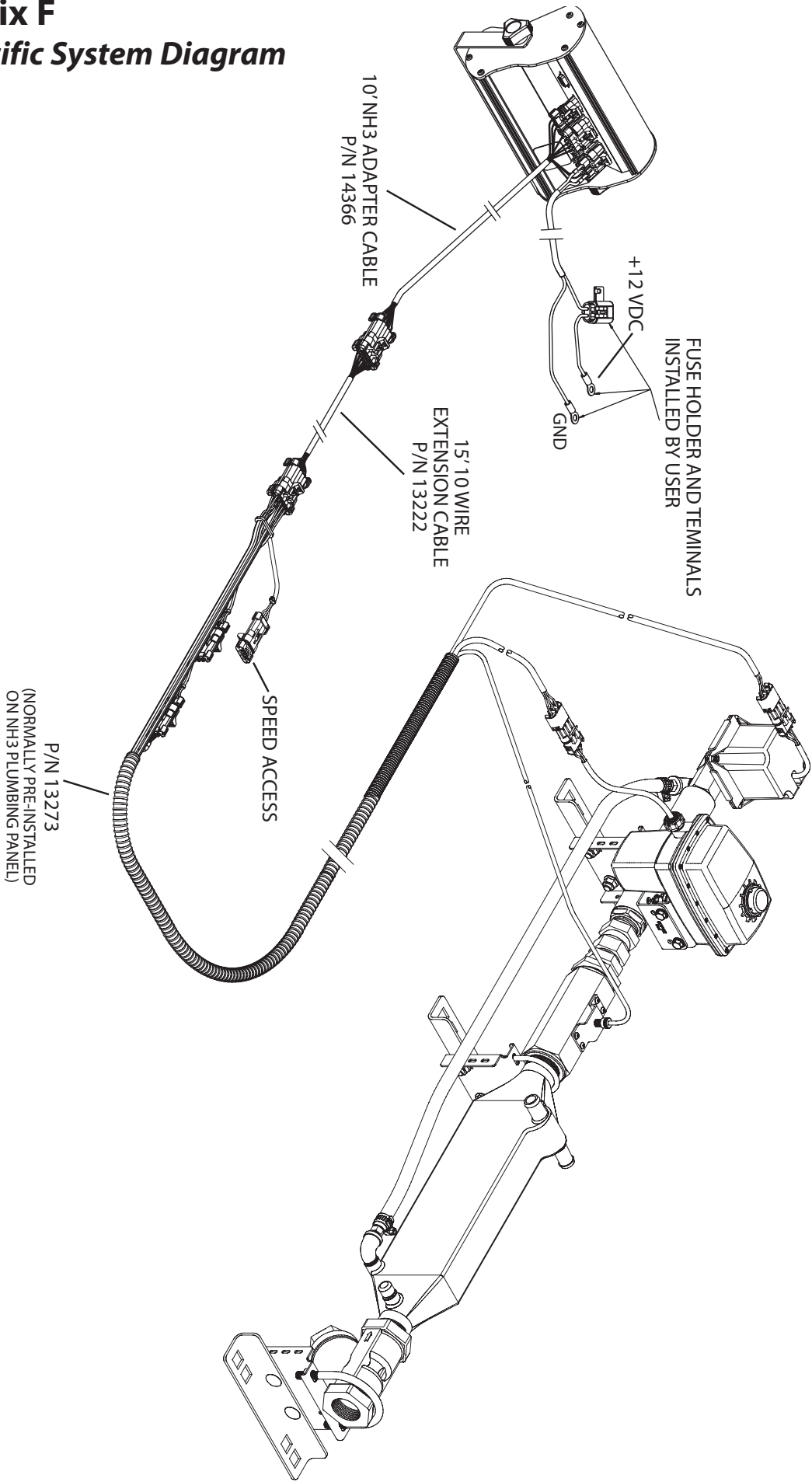

**Appendix F** (cont)

**Basic Overview of Typical Installation for NH3**

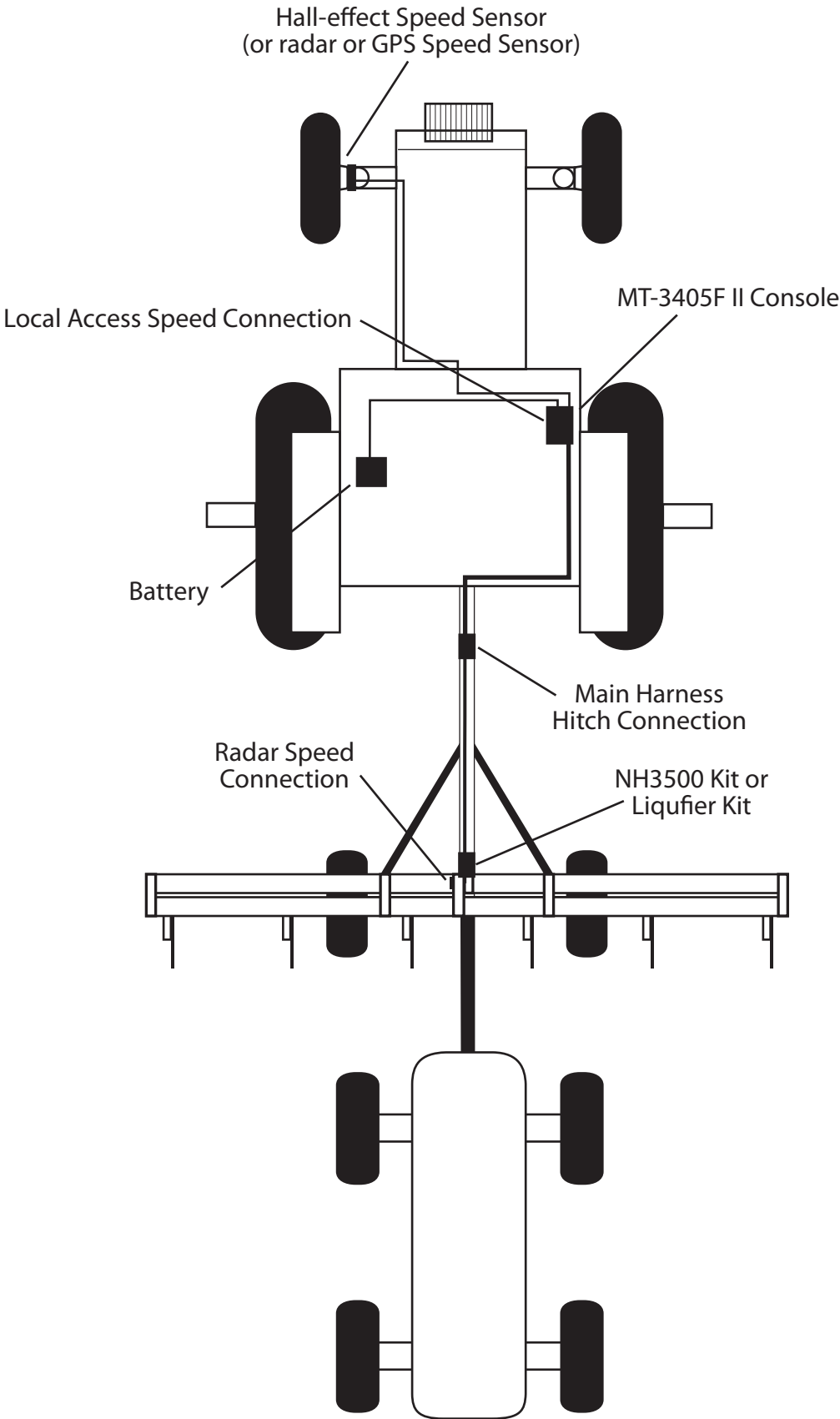

## Appendix F (cont)

### Component Parts for MT-3405F™ II for NH3 Kits

An NH3 system can be connected using the NH3 Main Harness (P/N 14366) shown below. The 10-pin connector plugs into the standard NH3 harness (P/N 13273) that is included in the NH3 kit.

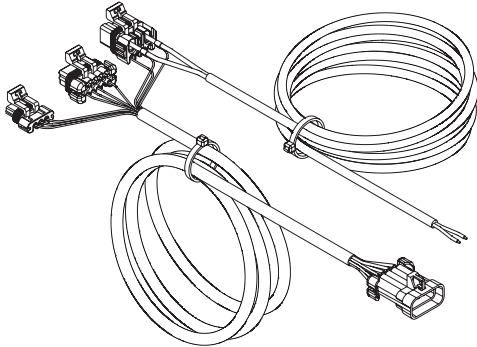

Main Harness - P/N 14366

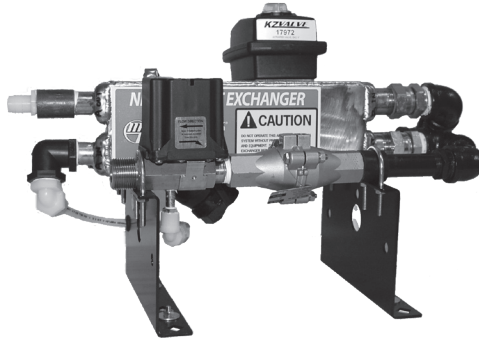

NH3500 Kit - P/N 01120

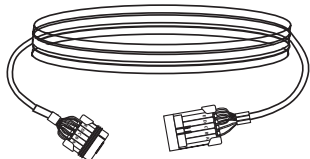

15' 10-Pin M/P  
Extension Cable  
P/N 13222



The Liquifier™ Kit - P/N 01097

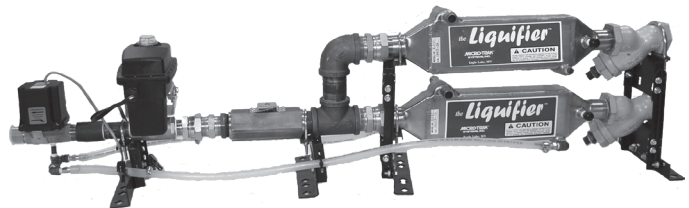

The Dual Liquifier™ Kit

### NH3500 Kit Installation

Remove any existing metering valves. If the old metering valve has a built-in manifold, it is recommended to install a separate new manifold for the NH3500 kit. Another option, although not recommended, is to use the existing manifold, making certain the old metering valve is in the maximum open position to allow for minimal restriction of flow through the plumbing. There also should not be any positive shut-off valves installed in the plumbing between the NH3500 kit shut-off valve and the knives.

Locate a convenient area on the applicator to install the NH3500 plumbing panel. When selecting an installation location, keep in mind that the hose from the break-away coupler must reach the strainer inlet with enough length to allow for proper operation of the break-away coupler disconnect mechanism and prevent kinking of the hose at hinge points. Also, the strainer's clean-out plug should be accessible for regular cleaning. Make certain that the area selected allows for enough length of the manifold hose, between the manifold and the servo valve outlet, to prevent kinking at hinge points.

**INSTALLATION NOTE:** It is recommended to use an NH3 compatible thread sealing compound such as "Slic-tite paste with Teflon", or a similar compound, on all pipe thread fittings. Slic-tite is manufactured by LA-CO Industries, Inc./Markal Company.

Remove the NH3500 plumbing panel from the shipping board. Install the plumbing panel on the tool bar frame using the bottom brackets, carriage bolts and flange lock nuts. Trim any excess length off of the bolts if required. Attach the hose from the break-away coupler to the strainer inlet. Check hose length for proper operation of the break-away coupler disconnect mechanism. Next, connect the manifold hose to the servo valve outlet. Check for proper hose length to avoid kinking at hinge points.

## Appendix F (cont)

### MT-3405F™ II Liquifier Installation

#### PRE-INSTALLATION

Remove the Liquifier plumbing panel from the shipping board. Before installing the unit on your applicator, make sure all three brackets rest on a flat surface. If necessary, loosen all six carriage bolts (two per bracket) at base of brackets to allow all brackets to rest flat on mounting surface of tool bar. Tighten carriage bolts only after insuring that all three brackets rest on bar and unit does not “teeter” on center bracket.

#### LIQUIFIER KIT INSTALLATION

Remove any existing metering valves. If the old metering valve has a built-in manifold, it is recommended to install a separate new manifold for the Liquifier kit. Another option, although not recommended, is to use the existing manifold, making certain the old metering valve is in the maximum open position to allow for minimal restriction of flow through the plumbing. There should not be any positive shut-off valves installed in the plumbing between the Liquifier kit shut-off valve and the knives.

Install the plumbing panel on the tool bar frame using the carriage bolts and flange lock nuts through the top and bottom brackets of the system. Trim any excess length off the bolts if required. Attach the hose from the breakaway coupler to the strainer inlet. Check for proper hose length for operation of the disconnect mechanism of the breakaway coupler. Connect the manifold hose to the servo valve outlet. Check for proper hose length to avoid kinking at the hinge points.

#### LIQUIFIER VAPOR TUBE INSTALLATION

Locate the 1/2" EVA vapor hose supplied with the kit. Starting on one half of the tool bar, connect the 1/2" hose to the outside steel vapor tube. Route the hose up the shank and along the tool bar frame to the inside steel vapor tube. Allow enough extra hose to avoid kinking at the hinge points. Cut the hose to length and attach to inside steel vapor tube. Install a 1 1/2" x 3/4" x 1/2" tee fitting approximately half way along this hose between outside and inside steel vapor tubes. *See Illustration Below.*

Locate the 3/4" EVA hose supplied with the kit. Connect one end to the 1/2" x 3/4" x 1/2" tee fittings and route along the tool bar frame to the vapor outlet connections on the Liquifier. *See Illustration Below.* Allow enough extra hose to avoid kinking at hinge points. Secure all hoses with properly sized hose clamps. Secure the hoses to the tool bar frame with cable ties.

**INSTALLATION NOTE:** It is recommended to use an NH3 compatible thread sealing compound on all pipe thread fittings.

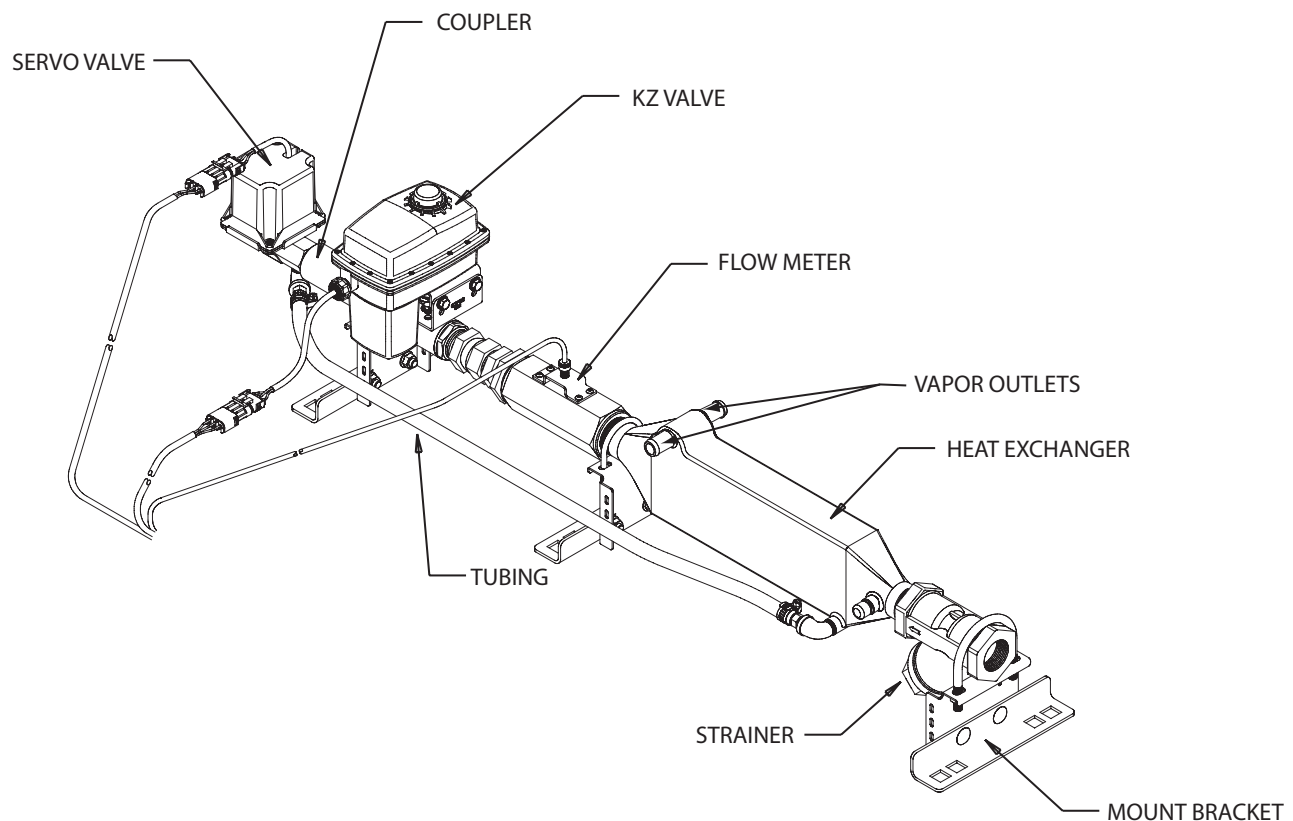

## Appendix F (cont)

### MT-3405F™ II NH3500 Vapor Tube Installation

Locate the 1/2" EVA vapor hose supplied with the kit. Starting on one half of the tool bar, connect the 1/2" hose to the outside steel vapor tube. Route the hose up the shank and along the tool bar frame to the inside steel vapor tube. Allow enough extra hose to avoid kinking at hinge points. Cut the hose to length and attach to the inside steel vapor tube. Install a 1/2" x 3/4" x 1/2" tee fitting approximately halfway along this hose between the outside and inside steel vapor tubes. **See illustration below.** Repeat the same procedure for the steel vapor tubes on the other half of the tool bar. Secure all hoses with properly sized hose clamps. Secure the hoses to the tool bar frame with cable ties.

Locate the 3/4" EVA hose supplied with the kit. Connect to one of the 1/2" x 3/4" x 1/2" tee fittings and route along the tool bar frame to other 1/2" x 3/4" x 1/2" tee fitting. Cut to length and install on the tee fitting. Allow enough extra hose to avoid kinking at hinge points. Now install a 3/4" x 3/4" x 3/4" tee fitting approximately halfway along this hose (center of the tool bar) between the other two tee fittings. Using an appropriate length 3/4" hose, connect this tee fitting to the vapor tube connection on the NH3500 plumbing panel. Secure all hoses with properly sized hose clamps. Secure the hoses to the tool bar frame with cable ties.

### NH3500 Kit — Vapor Line Installation

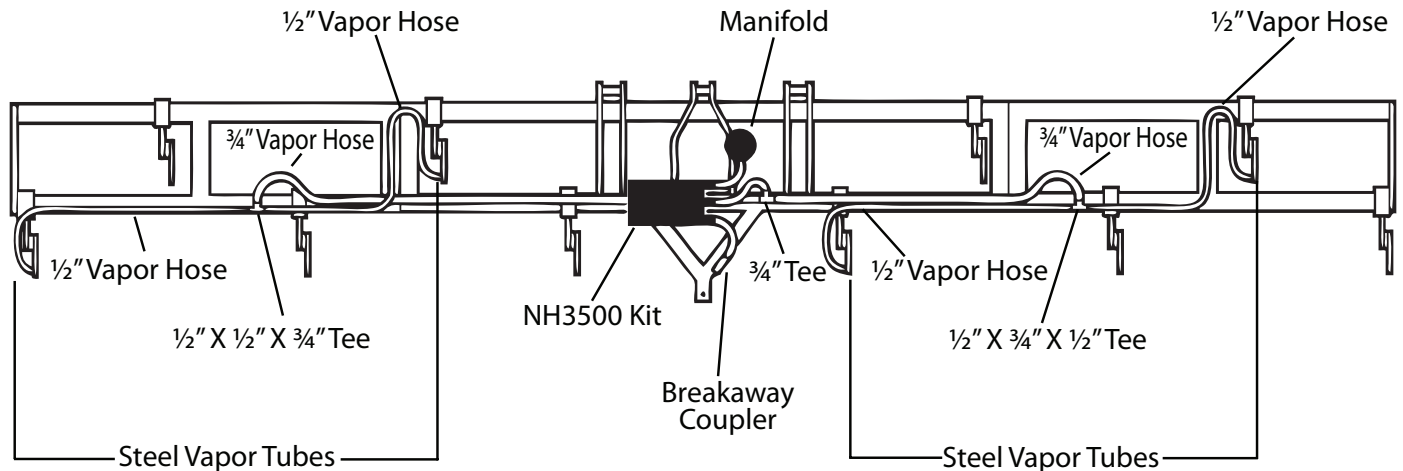

### Electrical Connections

The main wiring harness is made specifically for use on anhydrous ammonia applicators. The harness combines the wires for the servo valve, flowmeter, shut-off valve and remote access speed connector into a single 10-pin connector.

### FOR ALL NH3 KITS

Weld the steel vapor tubes to the back of your liquid tubes. All electronic equipment, including the console and radar speed sensor, **MUST BE DISCONNECTED BEFORE WELDING ON EQUIPMENT.**

The four steel vapor tubes should be evenly spaced across the applicator (two per side) and installed so that only their wear resistant surface contacts the soil. Mount the tubes just high enough to avoid plugging.

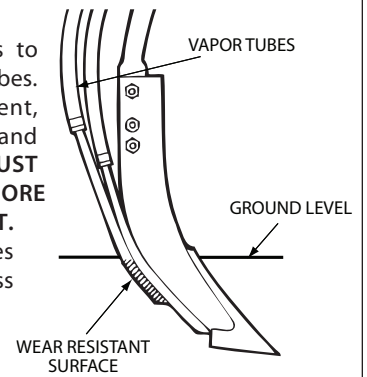

### PROCEDURE

Plug the 10-pin tower of the main harness onto the main plumbing panel harness. Use 15' M/P extension cable (provided) if necessary. Optional extension cables are available.

## Appendix F (cont)

### MT-3405F™ II Console Functions - in NH3 Mode

To put the MT-3405F™ II in NH3 mode, turn the console OFF, put the RUN/HOLD switch in HOLD and select Special Calibration by pressing the AUTO/MAN and CAL buttons while turning console power on. SPEC will appear in the left-hand display; release the AUTO/MAN and CAL buttons.

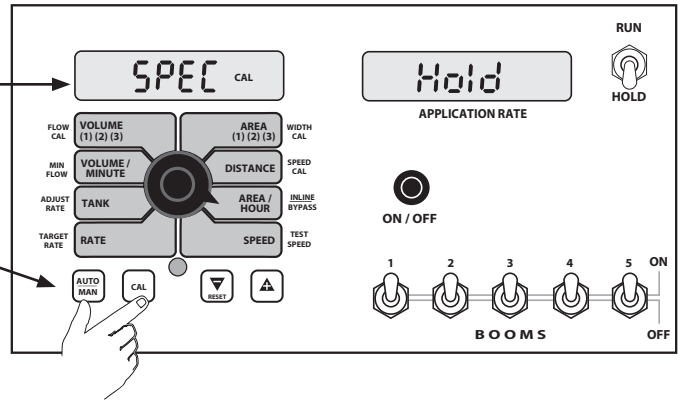

Turn the rotary switch to the AREA/HOUR position and use the "+" or "-" button to choose NH3. While in Special Calibration mode, other parameters can also be adjusted, *see Special Calibration section on page 25*. NOTE: to save the values you changed, you **MUST** exit Calibration by pressing the CAL button for one second.

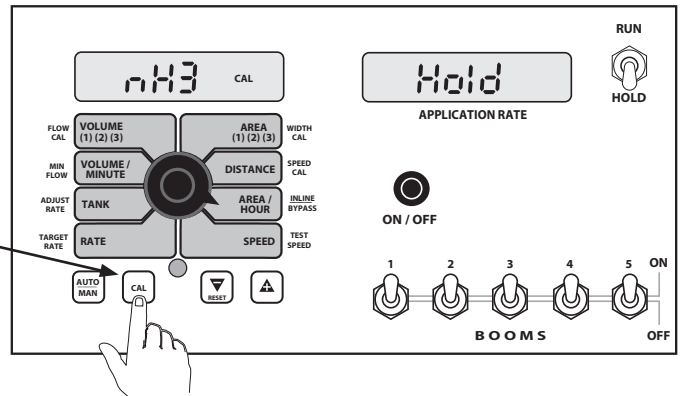

In NH3 mode, the console calculates rates and totals in lbs. (kg) of nitrogen (N) or anhydrous ammonia (NH3) as shown below.

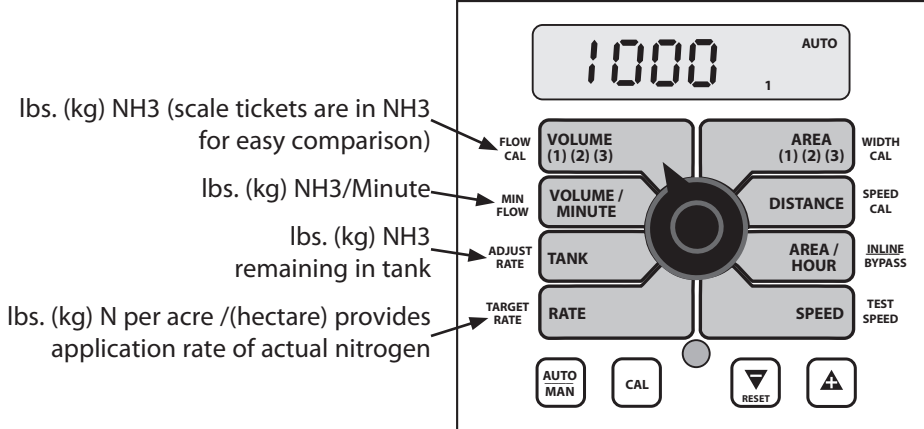

### Calibration Factors for NH3

To enter standard calibration mode, put the RUN/HOLD switch in the HOLD position and press the CAL button for 1 second. Some of the calibration factors are the same as a liquid system, but there are some important differences:

**TARGET RATE:** Use the "+" and "-" buttons to enter the desired application rate in pounds (kg) of actual "N" applied per acre (hectare).

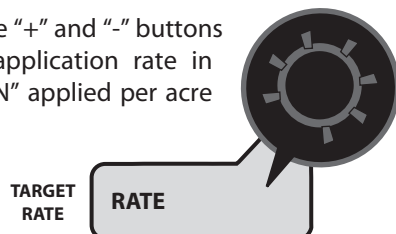

**ADJUST RATE:** Enter the desired amount of change in pounds (kg) of actual "N" applied per acre (hectare) for on-the-go adjustments to the Target Rate when operating in AUTOMATIC mode. Enter 0 to disable this feature.

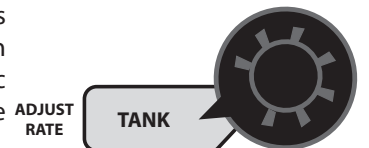

**MINIMUM FLOW:** Enter a minimum flow rate of 10.0 lbs. per minute (5.0 kg per minute) of NH3. This will prevent the system from applying below the recommended minimum rate for the Micro-Trak NH3 flowmeter.





# Appendix F (cont)

## MT-3405F™ II Calibration Factors for NH3

**FLOW CAL:** This position is used to calibrate the flowmeter for accurate liquid measurement. The flowmeter has been calibrated at the factory to read in pounds of actual "N".

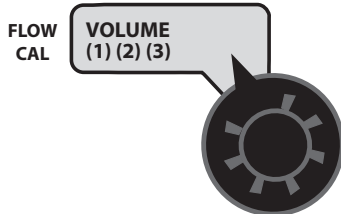

Your Micro-Trak NH3 flowmeter has been tested at the factory and assigned a "FLOW CAL" value (pulses/lb N) to make it operate properly with the MT-3405F II console. This number is stamped on the metal tag attached to the flowmeter. *See below.* This is a starting point only. The value must be fine tuned. *See Fine-Tuning Flowmeter Calibration for NH3 on page 57.* When entering the flow cal value, take note of decimal point placement.

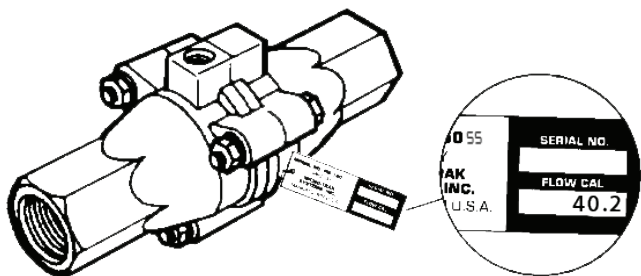

**WIDTH:** To calibrate the implement width the nurse tank must NOT be connected to the system. Turn on Boom 1

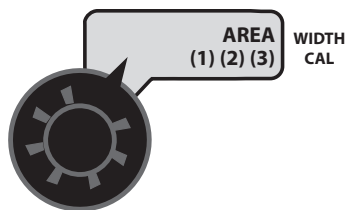

switch and put the RUN/HOLD switch in RUN. Use the "+" and "-" switches to adjust the number to the working width of your tool bar in inches (thousandths of meters).

**SETTING TOOL BAR WIDTH:** In order to accurately measure the pounds (kg) of "N" applied per acre (hectare), it is important to determine the correct "working" width. The "working" width is the width of ground being affected by any operation. This should be measured to the nearest inch (millimeter).

Your "working" width will be the number of knives times the knife spacing in inches (meters). For example, if you have 8 knives spaced at 30 inches, the working width is 240 inches. *See Illustration below.*

**SPEED CAL:** This position is used to calibrate the speed sensor for accurate speed and distance measurement. When this position is selected, the display will show the SPEED CAL value along with "CAL" on the display. See Speed Calibration

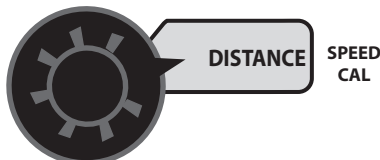

section (page 26) for details. To fine-tune the SPEED CAL, see Fine Tuning SPEED CAL for NH3 on page 56.



**INLINE/BYPASS:** Set to BYPASS (harness reverses the wires so the servo will run correctly).

**NOTE:** if used on a Micro-Trak NH3 system, it must be set to Bypass.

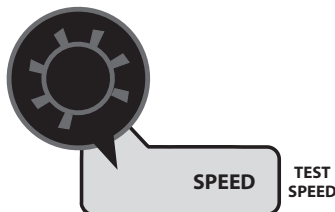

**TEST SPEED:** *Not used for anhydrous ammonia application.*

**EXITING CALIBRATION:** To save the changes you made, you MUST exit calibration by pressing and holding the CAL button until the CAL icon disappears and the warning light turns off.

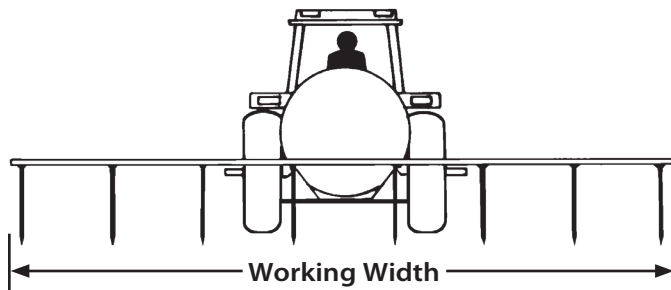

## Appendix F (cont)

### Fine Tuning Speed/Distance Calibration Value - NH3 Systems

This procedure is used to verify the speed/distance calibration. In order to achieve accurate measurements, each step in this fine tuning procedure should be performed as precisely as possible.

**CAUTION: Do not perform this procedure with the nurse tank connected to the system.**

#### PREPARATION

- Once the system is fully installed and calibrated, select a straight tract of ground that is similar to your actual field conditions and as level as possible.

**NOTE: Using a course with a different ground surface, such as a hard-surface road, will result in different readings than exact field conditions.**

- Measure a distance of 1000 feet (500 meters). Clearly mark the beginning and end points with flags or something highly visible to the operator.

#### PROCEDURE

- With the console turned ON, place the Run/Hold switch in the HOLD position. The HOLD icon will be displayed. Turn the rotary dial to the "DISTANCE" position. Be sure the display shows 0. If not, reset the distance counter by pressing and holding "RESET" until the display returns to 0 (approximately one second). The word CLEAR will be displayed when reset is pressed.
- You are now ready to drive the measured course. Pick a location on the vehicle to use as a marker for starting and stopping the distance counting function (door handle, mirror, step, etc.). You should begin driving the course well ahead of the starting flag and drive past the ending flag, using the Run/Hold switch to start and stop the counting function. It is not recommended to start from a dead stop at the starting flag and stop at the ending flag.
- Place the Run/Hold switch in RUN when the marker on the vehicle passes the starting flag to activate the distance counting function. The console display numbers will increase, adding to the distance total as you drive. Drive the pre-measured course and place the Run/Hold switch in HOLD, when the marker on the vehicle passes the ending flag, to stop the distance counting function. The console display should read "HOLD". **See Illustration.** Stop the vehicle in a level and safe area and continue with this procedure.

- With the rotary dial still at DISTANCE (SPEED CAL), press and hold the "CAL" key for one second. Once the console is in "CAL," CAL and the speed calibration value will be displayed. Momentarily press CAL and the word CAL will begin to flash and the distance travelled will be displayed.
- When the display shows distance ("CAL" is flashing), verify whether the number displayed is the exact distance you drove (within +/- 1 - 2 %). If not, press the "+" or "-" key to adjust the figure to match the distance you actually drove. If the display reads too high, use the "-" key to lower the displayed value. If the display reads too low, use the "+" key to raise the displayed value.
- When the number shown on the display matches (as closely as possible) the actual distance driven, you have arrived at the correct calibration value. If you cannot adjust the displayed distance to exactly match the actual distance driven, adjust the figure as close as possible to the actual distance. You may check the calibration number by momentarily pressing CAL. The word CAL and the SPEED CAL number will appear. Exit "CAL" by pressing "CAL" for one second.

The speed sensor is now calibrated. To verify proper calibration, repeat the procedure a second time. Write down the new speed calibration number and keep it in a safe place. If the calibration values are ever accidentally changed, you can simply re-enter this number.

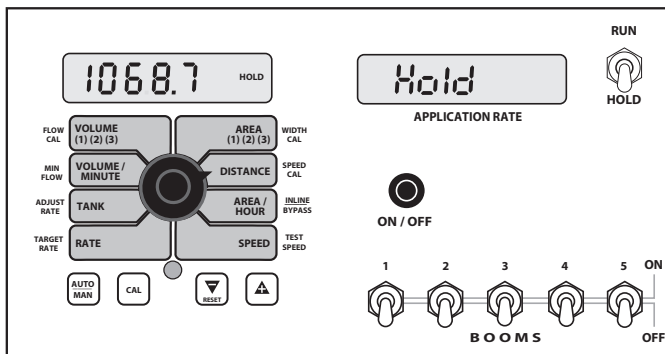

## Appendix F (cont)

### Fine Tuning Flow Calibration Value - NH<sub>3</sub> Systems

This procedure is used to verify and fine-tune the flowmeter calibration. Every flowmeter is calibrated with water at the factory and stamped with a calibration value. Enter that value as a starting point and use this procedure to fine-tune that value for your specific installation and NH<sub>3</sub> application (**please refer to Entering Flowmeter Calibration Value, page 25**).

#### PROCEDURE

1. Start with a full nurse tank. Make certain that you have an accurate scaled weight of the full tank. You will want to apply a minimum of 1,000 pounds of NH<sub>3</sub> for this procedure. The larger the volume of NH<sub>3</sub> used, the more accurate the calibration will be.
2. With the Run/Hold switch in HOLD, turn the rotary selector to the VOLUME (1) (2) (3) position. Select which pair of VOLUME/AREA counters (1, 2, or 3) that you want to use by using the "+" button ONLY to select the pair of counters as identified by the small number in the lower right area of the left-hand display. If you attempt to use the "-" button, it will clear the selected counter pair (CLEAR will be displayed before the counters are cleared). After you have selected the counter pair number, press and hold the RESET button until the display reads 0.0.
3. Proceed to the field and perform actual application (turn Boom 1 on, RUN/HOLD switch to RUN) until at least 1,000 pounds of NH<sub>3</sub> has been applied. (One nurse tank is preferred). The larger the volume of NH<sub>3</sub> applied, the more accurate the calibration will be. Obtain an accurate scaled weight of the partially used nurse tank. The difference between the starting and ending weight is your calibration weight.
4. Put Run/Hold switch in HOLD position. Compare the console's VOLUME reading with the known amount of NH<sub>3</sub> run. If the two amounts are within one or two percent, no fine tuning is required. If the two amounts are more than two or three percent different, continue with the next step.
5. With the console still in the VOLUME position, enter calibration, hold the CAL button until red warning light comes on; about one second. The display will show the flowmeter calibration value and the CAL icon.
6. Momentarily press the CAL button. The CAL icon will begin to flash and the total volume will be displayed. *See Illustration.*

7. When the TOTAL FLOW value is displayed, use the "+" or "-" button to adjust the value to match the amount of NH<sub>3</sub> run.
8. Momentarily press the CAL button. The CAL icon and the flowmeter calibration number will be displayed. You will notice that the flowmeter calibration value has changed. Write down the new flowmeter calibration value. This is your "fine tuned" calibration value, keep it for future reference.
9. Exit calibration by holding the "CAL" button until the red warning light goes out (about one second).

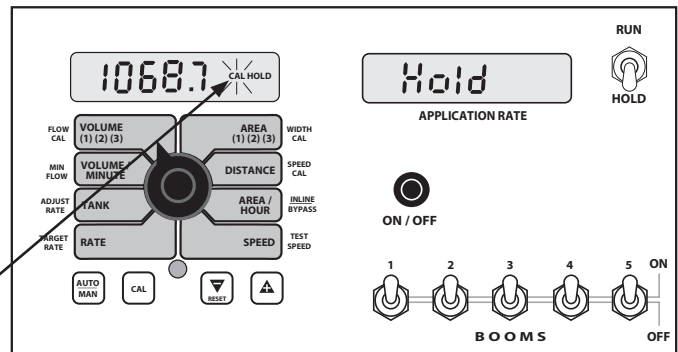
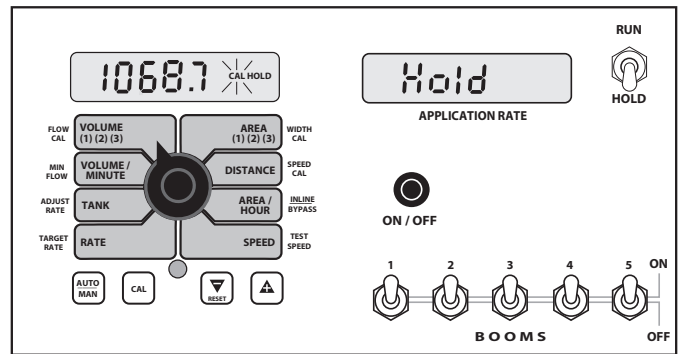

## Appendix F (cont)

### **Field Operation - Troubleshooting for NH3**

Always follow accepted safety precautions. Make sure that equipment is in good operating order. Before connecting the nurse tank to the applicator, check the electric shut-off valve of the MT-3405F™ II system for proper operation.

After changing nurse tanks or after other periods of long shut-down, operate the system in MAN until the application rate stabilizes. This allows the heat exchanger to reach operating temperature before selecting AUTO. Erratic operation may be experienced if AUTO is selected before operating temperature is reached.

Manifold pressure is very important for good distribution of NH3. Use barbed fittings with properly sized orifices or an adjustable manifold to maintain adequate pressure. If manifold back pressure is too low, proper cooling will not be achieved, vapor bubbles will be allowed to enter the flowmeter, and readings will be inaccurate. Typical manifold pressure ranges from 15 to 60 PSI (1 to 4 bar) depending on application rates and ambient temperature. If manifold pressure stops climbing but FLOW RATE continues to climb, vapor bubbles are present.

In hilly or rough conditions the nurse tank dip tube will not remain submerged, allowing extra vapor in the system. This vapor is too much for the heat exchanger to condense and the system will exhibit erratic operation. If the dip tube remains out of liquid, operation may appear to be normal, but the system is simply metering vapor. If this occurs, you will notice extremely low manifold pressure. Change tanks before the NH3 level is low enough to cause these problems.

In NH3 control systems, location of the frost build-up is an indication of system performance. The NH3 kit will normally have frost on the output side of the servo valve and in some cases, a small amount on the bottom portion of the heat exchanger. Frost before the servo valve indicates excessive pressure drop in the delivery system or restricted vapor lines.

The strainer is a common source of excessive pressure drop and should be cleaned regularly. **AFTER COMPLETELY DRAINING THE SYSTEM**, remove the large plug and carefully clean the strainer's screen. Also, periodically check the vapor tubes for obstructions.

#### **Additional Troubleshooting Tips for NH3**

See Troubleshooting section, starting on page 33.

# Appendix F (cont)

## MT-3405F™ II NH3 Specific Wiring Diagram

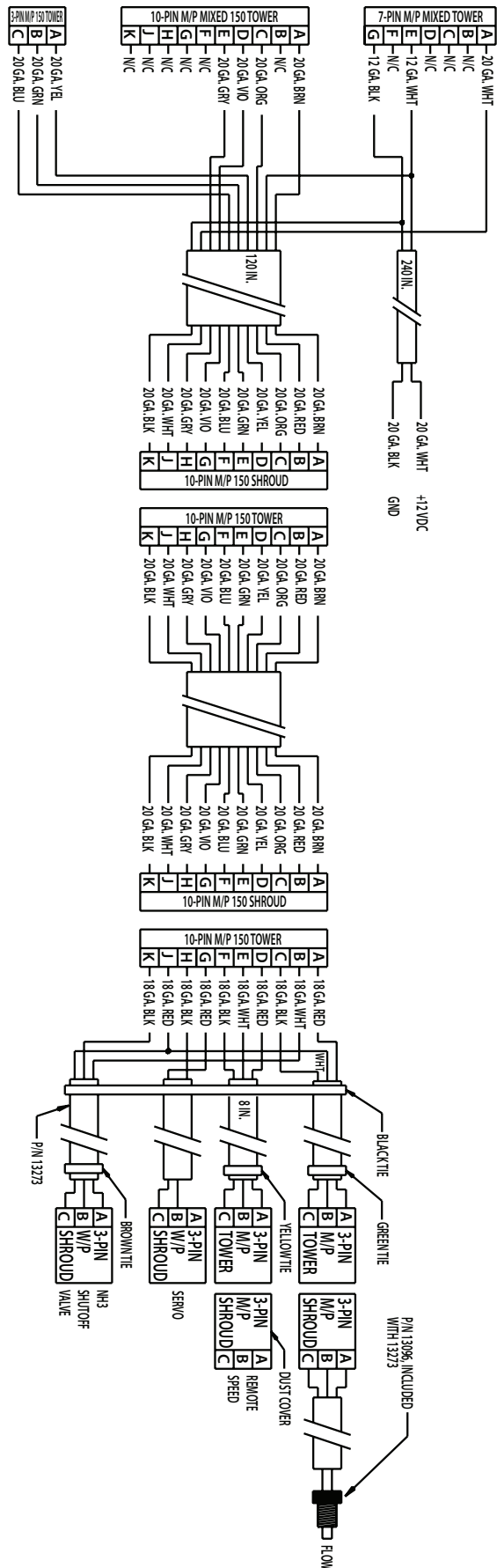

## Appendix F (cont)

### MT-3405F™ II NH3 Specific Flowmeter Assembly (FM-750 N)

**IMPORTANT:** Opening the flowmeter will void the Flow Calibration value assigned to your unit. However, you may need to take the flowmeter apart for periodic cleaning or to remove an obstruction. *See illustration below for flowmeter reassembly instructions.*

#### TO OPEN THE FLOWMETER

Disconnect the hose from servo valve to manifold. Loosen the union hex closest to the heat exchanger. Remove the two "U" bolts that hold the servo/flowmeter assembly to the brackets. Unscrew the union from the heat exchanger and remove the servo/flowmeter assembly.

Use running water to rinse the assembly of any accumulated dirt. Remove the three flowmeter bolts, carefully open the flowmeter and remove the turbine. Thoroughly clean turbine and housings of any foreign material (dirt, pieces of teflon tape, rust on magnets, etc.).

Set and spin the turbine in each flowmeter housing half. It should spin freely. If not, remove the turbine, wipe the shaft and try again.

#### TO ASSEMBLE THE FLOWMETER

Place the servo, flowmeter end up, in a vice or other suitable fixture. Set turbine in non-sensor housing. Properly position gasket on housing. (Gasket may be reused a few times but will eventually need to be replaced.) Pipe thread compound is not absolutely necessary but will insure a good seal. Be careful not to get compound inside flowmeter or turbine will stall. Carefully put other flowmeter housing (sensor half) in place. (Position the housing so that the two square lugs are lined up with each other.) Drop all three bolts into holes. Hold lock washers in place and finger tighten all three nuts. Nuts should be torqued to 120 in./lb. (13.56 nw/m). Attach tag by running wire between a bolt and the housings, and twisting.

After assembly, shaking flowmeter end-to-end should produce a "rattling" sound (shaft end play). Blowing into the meter from either end should cause the turbine to spin freely. If the turbine only spins from one direction, install the flowmeter so that the liquid flows in that direction.

Start with original calibration number and follow procedure in manual for verifying flowmeter accuracy.

#### WARNING

TO PREVENT SERIOUS INJURY, DO THE FOLLOWING:

1. **ALWAYS WEAR** gloves, goggles, and other necessary equipment when handling NH3 apparatus.
2. **DO NOT** cross thread. Use anti-seize lead base thread compound.
3. **THOROUGHLY BLEED** hoses before disconnecting NH3 apparatus.
4. **COMPLETELY EVACUATE** NH3 apparatus before servicing.

Complete assembly  
FM750 N Flowmeter  
P/N 10899

Housing FM 750 N with Sensor  
Receptacle, Including Bearing  
P/N 10145

Gasket Pin  
P/N 10137

Housing, Includes Bearing  
P/N 10116

Turbine  
P/N 14836

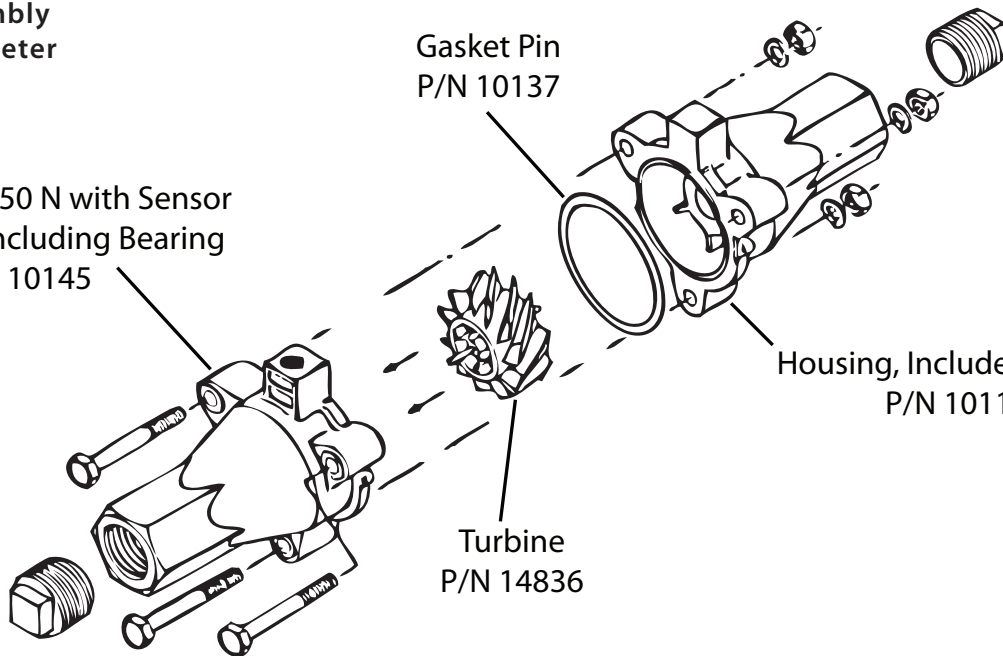

## Appendix F (cont)

### MT-3405F™ II NH3 Specific Flowmeter Assembly (FM-1500 N)

**IMPORTANT:** Opening the flowmeter will void the Flow Calibration value assigned to your unit. However, you may need to take the flowmeter apart for periodic cleaning or to remove an obstruction. See Illustration below for flowmeter reassembly instructions.

#### TO REMOVE THE FLOWMETER

Loosen two 1/2" bolts securing unit (shutoff valve end) to tool bar. Loosen union between flowmeter and shutoff valve. Slide shutoff valve away from flowmeter and unscrew flowmeter from heat exchanger.

#### TO DISASSEMBLE THE FLOWMETER

Remove retainer clip from one end and slide out internals. See Illustration below. Be careful not to bend turbine shaft.

Clean and inspect parts.

Assemble in reverse order.

After assembly, shaking flowmeter end-to-end should produce a "rattling" sound (shaft end play). Blowing into the meter from either end should cause the turbine to spin freely. If the turbine only spins from one direction, install the flowmeter so that liquid flows that direction.

If turbine does not spin freely, flowmeter may require repair. Turbines and bearing replacement kits are available.

Before reconnecting the union, loosen all six 3/8" carriage bolts at bottom of mounting bracket uprights. Tighten union then re-tighten 3/8" carriage bolts. This ensures that unit sits flat on tool bar and does not "teeter" on center bracket.

**NOTE:** Start with original calibration number and follow procedure in manual for verifying flowmeter accuracy.

#### WARNING

TO PREVENT SERIOUS INJURY, DO THE FOLLOWING:

1. **ALWAYS WEAR** gloves, goggles, and other necessary equipment when handling NH3 apparatus.
2. **DO NOT** cross thread. Use anti-seize lead base thread compound.
3. **THOROUGHLY BLEED** hoses before disconnecting NH3 apparatus.
4. **COMPLETELY EVACUATE** NH3 apparatus before servicing.

Complete assembly  
FM1500 N Flowmeter  
P/N 14348

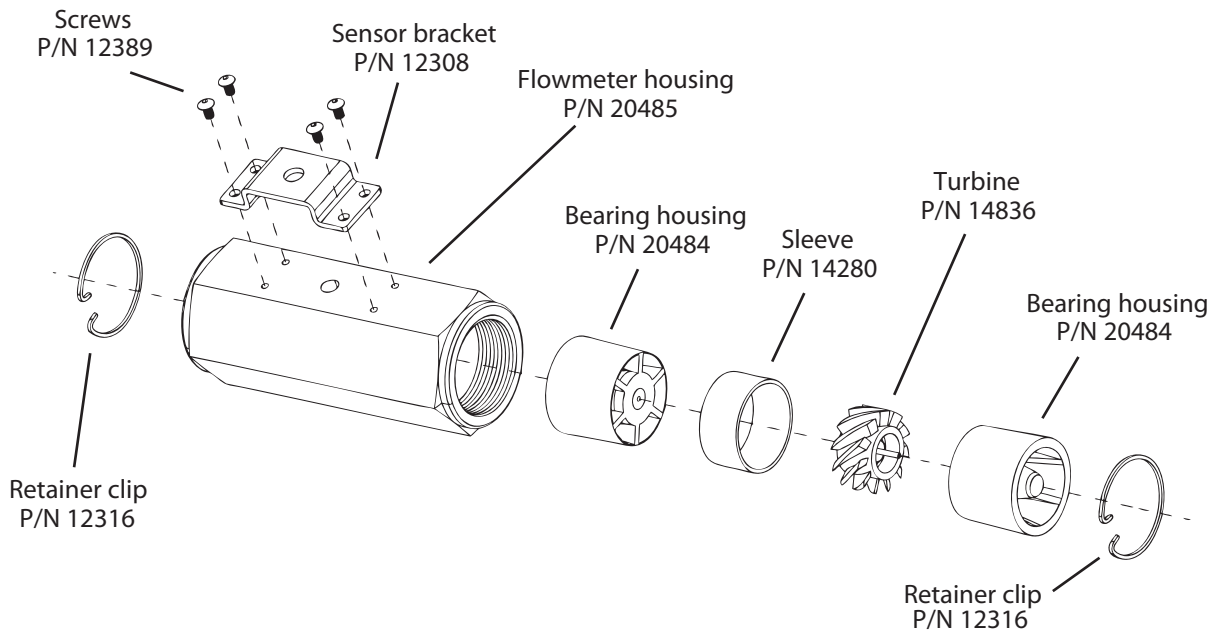

# Appendix G

## Various Ball Valve Configurations

Some basic 2, 3 & 4-wire configurations are shown below. If you need assistance for wiring other than shown, contact Micro-Trak for wiring instructions.

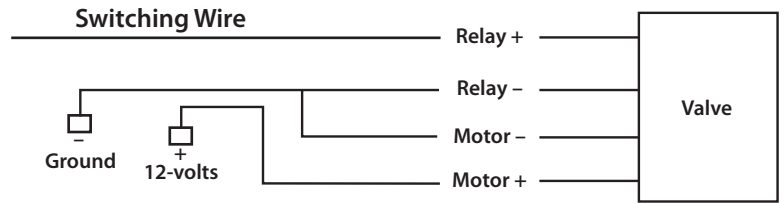
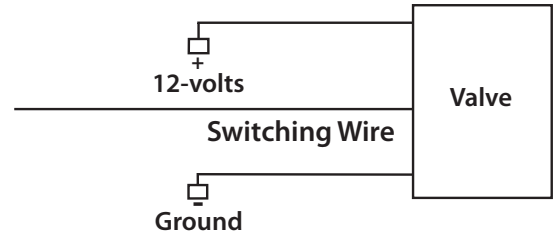

For 2-wire (voltage reversing) valves, use P/N 17159 )2-wire ball valve adapter cable, 5 Boom). This cable would be used in place of the standard boom harness P/N 14319.

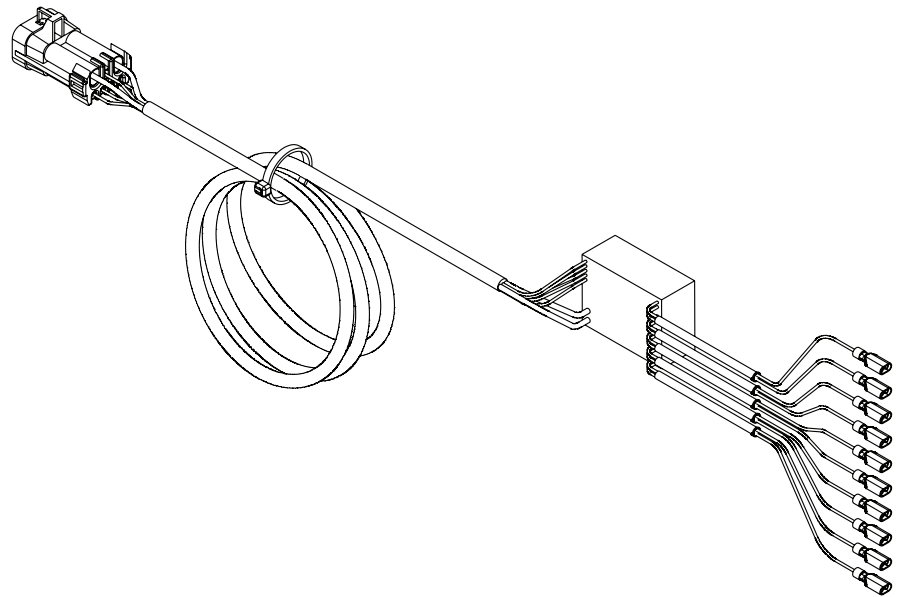



# Appendix H

## Using the MT-3405F™ II with VRA

The MT-3405F™ II has a 9-pin serial connector on the back panel which allows it to be connected to any “GPS / Mapping Controller”.

A GPS/Mapping system typically consists of special hardware that runs on a laptop/PDA, or dedicated mapping controller. The MT-3405F™ II may be connected to any such device that supports Micro-Trak products.

This allows for the following mapping activities:

### “AS APPLIED” MAPPING

In this case the GPS/Mapping Controller just collects data. In either MAN or AUTO operating modes, the console simply reports its current application rate.

### VARIABLE RATE APPLICATION

In order to accept VRA commands, the console must be operating in ‘AUTO’.

While in ‘AUTO’, the GPS/Mapping computer is in control of the application rate, and consequently the console’s adjust rate buttons (+ and -) are disabled.

When outside of the prescribed mapping area, the GPS/MAPPING computer puts the MT-3405F™ II in “Hold” (stops spraying) by simply sending a target rate of zero.

### MANUAL OVERRIDE OF VRA

There may be times when the operator needs to apply more or less than the prescribed rate. In such a case, pressing ‘MAN’ allows the operator to make adjustments using the + and - buttons. To resume the prescribed rate, simply exit the manual override by pressing the AUTO button.

**NOTE: While in MAN override, the console will not miss any new rate commands sent by the GPS/Mapping Controller. They are simply ignored until the user toggles back to AUTO, at which point the most recent prescribed rate is resumed.**

## VRA Testing Procedures:

### CABLE CONNECTION

Use a standard pin-for-pin (not “null-modem”) serial communications cable to connect the Micro-Trak console to the GPS/Mapping controller. One end of the cable should be a DB9 male and the other end a DB9 female.

**NOTE: Only 3 wires are used (Tx, Rx and Gnd: Pins 2, 3 & 5).**

### COMMUNICATIONS SETTINGS

The Micro-Trak console uses the following serial settings:  
**9600 baud, 8,N,1** (8 data bits, no parity, 1 stop bit).

**NOTE: These numbers are in the software NOT the Micro-Trak Console.**

### FUNCTIONALITY TEST

You can verify the connection and functionality by using the standard “HyperTerminal” communications program, which can be found on any computer running MS-Windows.

Connect a computer (PC, laptop) to the Micro-Trak console, and configure HyperTerminal (‘Port Settings’ tab) as follows:

- Select a known working COM port on your computer
- Select the communication settings as listed above:

**IMPORTANT: ‘Flow Control’ must be set to none.**

The following tests assume the Micro-Trak console is power up, and ‘AUTO’ is selected (**DOES NOT** require speed or flow signal).

1. **Put console into HOLD, by sending a target rate of zero.**  
Type the following, a signal character at a time: **S,0**, (capital S; comma; then ZERO and a trailing comma).

The console goes into HOLD immediately after the last comma.

2. **Send a new target rate.**  
Send a target rate of 12.3 by typing: **S,123**,  
Once the trailing comma is sent, the console immediately changes to the new target rate of 12.3.

3. **Verify the new rate**  
Retrieve current rate status by typing one character: **R**  
The console immediately responds with a ‘D’ followed by a number of comma-separated fields (datalist):
  - The 1st data field (D,123,) is the current **target** rate [12.3].
  - The 2nd data field (D,123,###, is the **actual** rate.

# Appendix I

## Radar Adapter Cables

In-Cab John Deere Metri-Pack Connector  
8000/9000 Series

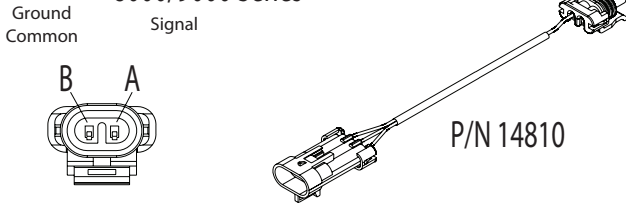

RADAR	CONNECTOR	SIGNAL PIN
DICKEY-john	Amp	2
DICKEY-john	Cannon	3
DICKEY-john	Deutsch	3
DICKEY-john	Ford	2
DICKEY-john	Packard	B
In-Cab JD (8000 & 9000's)	Metri-Pack	A
Magnavox & Phillips	Packard	C
Raven	Conxall	3
Vansco	Amp	2

DICKEY-john Radar Amp Connector

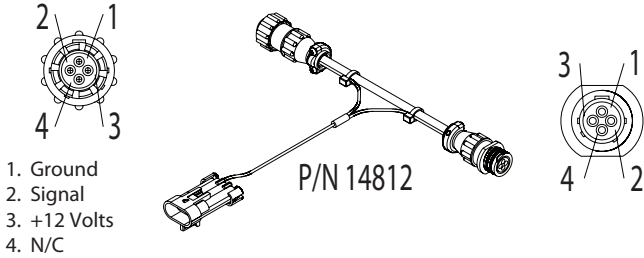

DICKEY-john Radar Cannon Connector

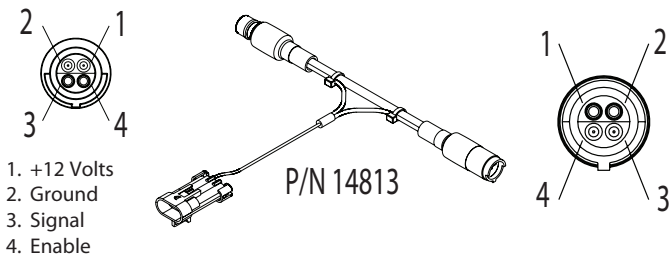

DICKEY-john Radar Deutsch Connector

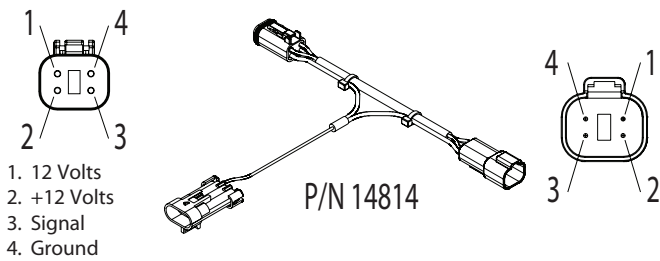

DICKEY-john Radar Ford Connector

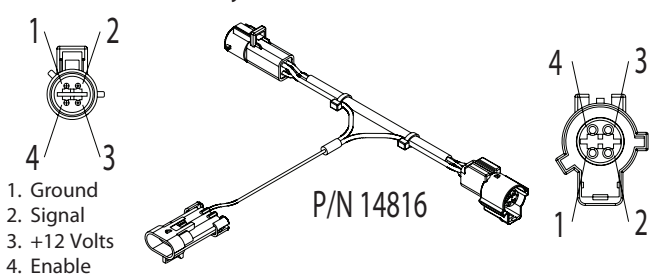

Vansco Radar Amp Connector

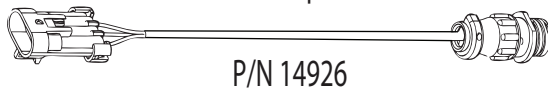

In-Cab John Deere "Y" Connector

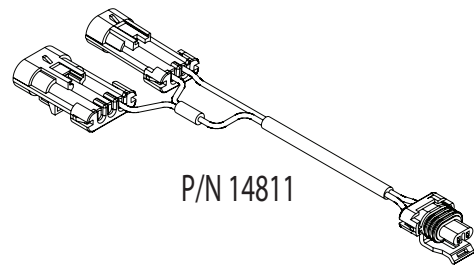

DICKEY-john Radar Packard Connector

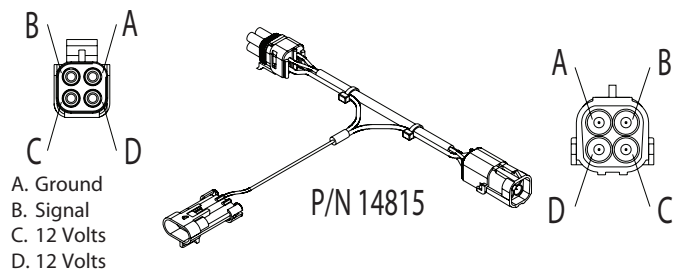

Magnavox & Phillips Radar Packard Connector

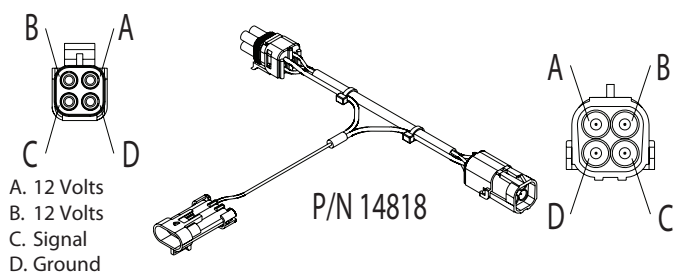

Raven Radar Conxall Connector

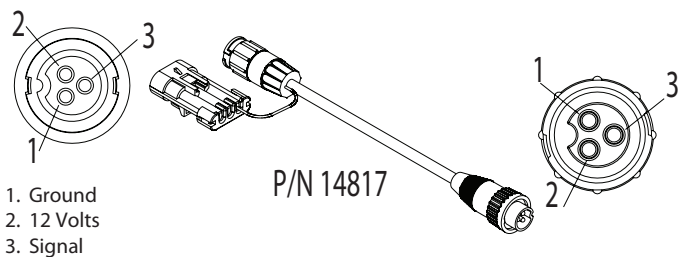

# Appendix J

## Calculating Planter Drive Ratio

The value for Driven or Drive Sprocket refers to the number of teeth on the sprocket.

To calculate Ratio for a single stage chain drive, use the following equation:

(Driven Sprocket ÷ Drive Sprocket)

**EXAMPLE:  $32 \div 16 = 2.000$**

This means the Drive Sprocket will need to make 2 complete revolutions in order for the Driven Sprocket to make 1 revolution.

To calculate Ratio for a two stage chain drive, use the following equation:

(First Stage Driven Sprocket ÷ First Stage Drive Sprocket) x (Second Stage Driven Sprocket ÷ Second Stage Drive Sprocket)

**EXAMPLE:  $(32 \div 16) \times (28 \div 16) = 3.500$**

In the above example, the First Stage Drive Sprocket will need to make 3.5 complete revolutions in order for the Second Stage Driven Sprocket to make 1 revolution.

To calculate Ratio for a three stage chain drive; use the following equation:

(First Stage Driven Sprocket ÷ First Stage Drive Sprocket) x (Second Stage Driven Sprocket ÷ Second Stage Drive Sprocket) x (Third Stage Driven Sprocket ÷ Third Stage Drive Sprocket)

**EXAMPLE:  $(32 \div 16) \times (28 \div 16) \times (24 \div 18) = 4.666$**

In the above example, the First Stage Drive Sprocket will need to make 4.666 complete revolutions in order for the Third Stage Driven Sprocket to make 1 revolution.

## Calculating your Flow Cal for a Planter Drive

1. Rows equals the number of rows the drive is running.  
**ROWS = \_\_\_\_\_**
2. How many seeds are dispensed per revolution of your Seed Meter Disc?  
**SMD = \_\_\_\_\_**
3. What is the Ratio of hydraulic motor revolutions to seed meter revolutions?  
**RATIO = \_\_\_\_\_ to 1**
4. How many teeth are there on your Motor Sensor Sprocket?  
**MSS = \_\_\_\_\_**

1000 Seeds ÷ **ROWS** = Seeds per Row  
 Seeds per Row ÷ **SMD** = Seed Meter Revolutions  
 Seed Meter Revolutions x **RATIO** = Motor Revolution  
 Motor Revolution x **MSS** = Pulses per 1000 Seeds (Flow Cal)

**EXAMPLE:**

**ROWS = 12**

**SMD = 30**

**RATIO = 4.0**

**MSS = 16**

1000 Seeds ÷ 12 = **83.333**

83.333 ÷ 30 = **2.777**

2.777 x Ratio = **11.111**

11.111 x 16 = **177.8**

**177.8 = Flow Cal or Pulses per 1000 seeds.**

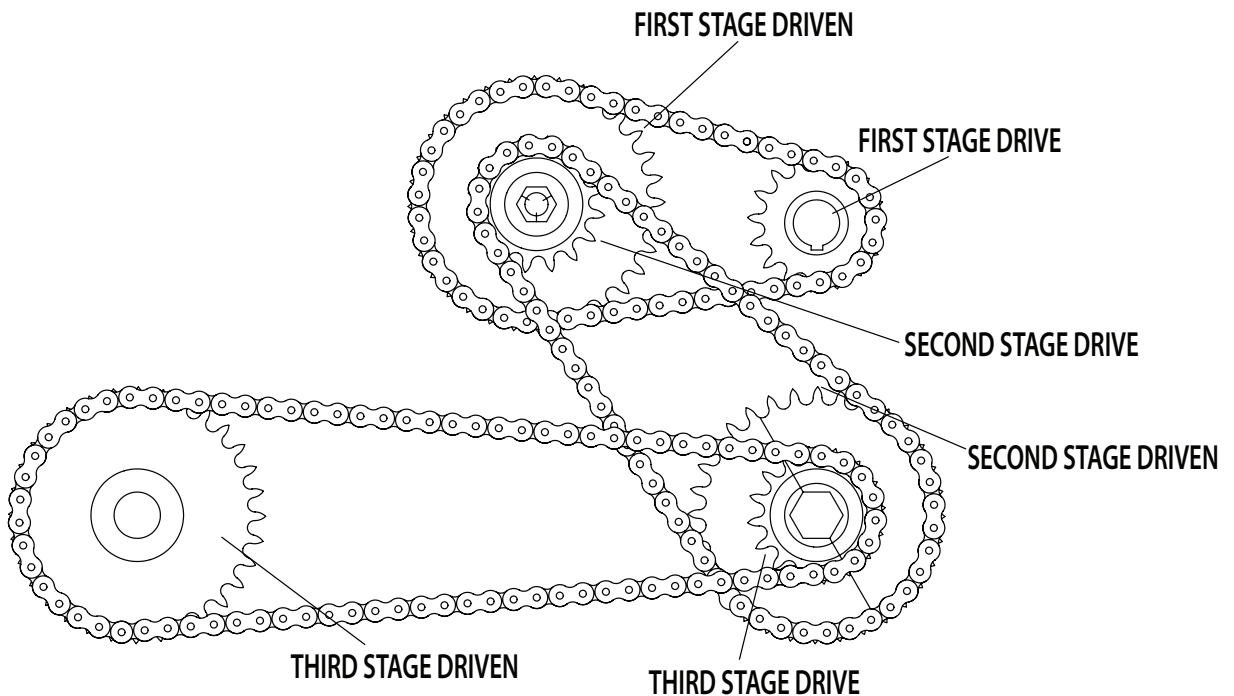

## Appendix J (cont)

### Calculating your Hydraulic Oil Needs

1. What is your Maximum Planting Speed in miles per hour?

**MPS** = \_\_\_\_\_

2. What is the closest Desired Seed Spacing in inches?

**DSS** = \_\_\_\_\_

3. How many seeds are dispensed per revolution of your Seed Meter Disc?

**SMD** = \_\_\_\_\_

4. What is the Ratio of hydraulic motor revolutions to seed meter revolutions?

**RATIO** = \_\_\_\_\_ to 1

5. What is the Displacement in Cubic Inches of the hydraulic motor on your planter drive assembly?

**CID** = \_\_\_\_\_

#### EXAMPLE:

**MPS** = 5

**DSS** = 6.5

**SMD** = 30

**RATIO** = 5.333

**CID** = 4.9

$(\text{MPS} \times 5280) \times 12 = \text{Inches traveled per hour}$

$\text{Inches traveled per hour} \div \text{DSS} = \text{Seeds per hour}$

$\text{Seeds per hour} \div \text{SMD} = \text{Seed meter revolutions per hour}$

$\text{Seed meter revolutions per minute} \times \text{Ratio} =$

**Hydraulic motor revolutions per minute**

$\text{Hydraulic motor revolutions per minute} \times \text{CID} =$

**Cubic inches of hydraulic oil per minute**

$\text{Cubic inches of hydraulic oil per minute} \div 231 =$

**Gallons of hydraulic oil per minute**

$(5 \times 5280) \times 12 = 316500 \text{ inches traveled per hour}$

$316800 \div 6.5 = 48738.46 \text{ seeds per hour}$

$48738.46 \div 30 = 1624.6 \text{ seed meter revolutions per hour}$

$1624.6 \div 60 = 27 \text{ seed meter revolutions per minute}$

$27 \times 5.333 = 144.4 \text{ hydraulic motor revolutions per minute}$

$144.4 \times 4.9 = 707.6 \text{ cubic inches of hydraulic oil per minute}$

$707.6 \div 231 = 3 \text{ gallons of hydraulic oil per minute}$

# Appendix K - Motorized Hydraulic Flow Control Valve

## How do I select the correct control valve?

To select the valve best suited for your application, you need to know the maximum hydraulic oil flow rate; the following information may be helpful:

### 1. Hydraulic Motor Displacement

Determine the motor displacement required for your application. Motor displacement is the amount of oil moved per revolution of the motor (typically rated in cubic inches). This specification will be determined by the torque and rpm requirements of the delivery system. Your motor supplier will be the best resource for matching a suitable motor with your application needs. (If the motor rating is given in cubic centimeters simply multiply cubic centimeters by .061 to convert it to cubic inches.)

### 2. Maximum Hydraulic Oil Flow

Calculate the maximum oil requirements for your application. Simply multiply the maximum motor rpm by the motor displacement. For example, the maximum oil flow for a 300 rpm motor with a displacement of 4.8 is 1440 (300 x 4.8 = 1440).

### 3. Maximum Gallons per Minute of Oil Flow

Calculate the maximum gallons per minute (GPM) of oil flow required for your application. There are 231 cubic inches of hydraulic oil per gallon so simply divide the maximum oil flow by 231 and multiply by .8 (control valve rating factor). For this example, the maximum GPM of oil flow is 4.99 (1440 ÷ 231 x .8 = 4.99). The control valve best suited for this example is the 5 GPM valve (rated just higher than maximum GPM requirement of 4.99).

**Bigger isn't always better. Selecting the 10 GPM valve (or larger) would result in roughly half of the control range of the valve being unused. For optimum system performance, select the control valve with the rating closest to the maximum GPM requirements of your application. Continue reading for valve options and specifications.**

## Typical Applications

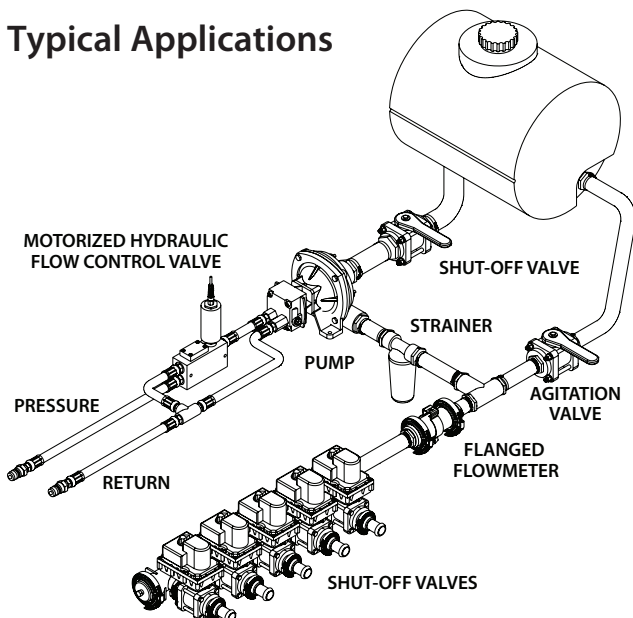

## Specifications

### DESCRIPTION

The Motorized Hydraulic Flow Control Valve is a two wire polarity reversing valve. Change polarity to open or close the valve, cut 12VDC power to hold valve at desired setting. All that is required for basic control is a double-pole double-throw switch. It also works great with Micro-Trak's full line of automatic rate controllers.

### PUMP COMPATIBILITY

- Open (Recommended)
- Closed
- Load Sense

### OPERATING PRESSURE

- 3000 PSI Maximum

### FLOW RANGES

- Part # 13859 0-5 GPM
- Part # 14885 0-10 GPM
- Part # 13857 0-15 GPM
- Part # 13860 0-20 GPM
- Part # 13858 0-35 GPM

### PORT SIZES

- #8
- #8
- #8
- #8
- SAE #12

### OPERATING SPEED (Fully closed to fully open @ 12V DC)

- 3.5 sec.

### AVAILABLE OPTIONS

- Bypass Dump Valve
- Adjustable Pressure Relief

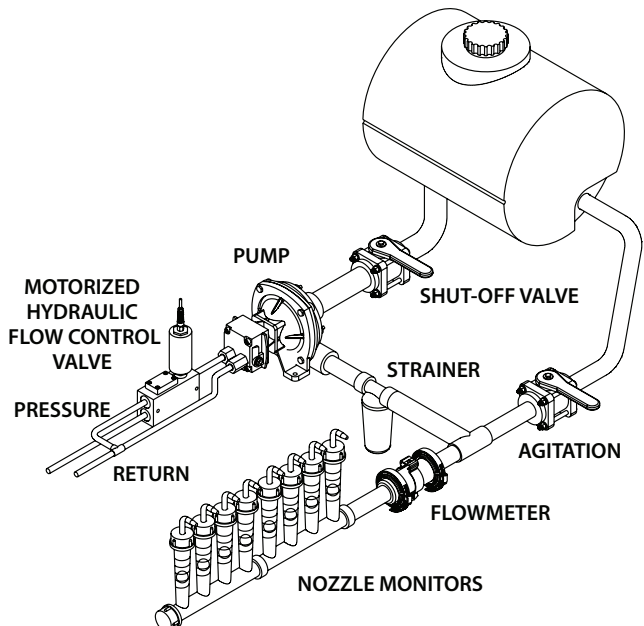

# Appendix L

## Secondary Boom Control

For liquid material there is an optional “Dual Boom” feature that allows a secondary boom line (SBE) to be turned On/Off by using either the Flow or Speed as a trip point.

Please note that this feature uses the “Relief Output” (see page 22). In other words you must choose between either a Relief or SBE output - but NOT both at the same time.

As an example, the MT-3405 front panel switches control the sections on the primary boom, which works for the normal operating range of the nozzles. However, there may be instances where extra flow is needed (greater than the output capacity of the nozzles on the primary boom) - in which case a secondary boom line can be turned on to meet the extended target application rate.

### ENABLING THE ‘DUAL BOOM’ FEATURE

In order to enable this feature and set up the trip points, turn the rotary knob to the ‘WIDTH’ position, enter Calibration mode, and make sure the console switch is set to HOLD.

The currently selected control units, Speed or Flow, will be displayed

Select either FLOW or SPEED control of the secondary boom by pressing the CAL key to toggle the right-hand display between ‘FLD’ (flow-based control) and ‘SPEED’ (speed-based control).

### SETTING THE ‘TRIP’ POINTS

When the desired control mode is displayed, use the + and - (RESET) keys to adjust the value. Entering a value will automatically clear the value for the alternate control setting. For example if Flow was selected with trip-point value of 7.2 GPM, entering a value of 10.0MPH for Speed will enable Speed control and disable Flow control (‘OFF’).



### FLOW

If in Flow control, *FLD* will display in the Application Rate (right) display and the trip-point value will be displayed in Gallons per Minute, (or Liters per Minute) in the Data (left) display. If the flow (VOLUME/MINUTE) ever exceeds this trip point setting, then the Secondary Boom Enable output goes high, turning on the Secondary boom. When the flow drops below the trip point the Secondary boom will turn off.

**NOTE:** Typically you want the secondary boom to turn on when the primary boom reaches a certain pressure. To determine the trip point value, consult the manufacturers nozzle charts and do the following calculation, if the chart indicates that your nozzle output is 0.2 gpm at 40 psi, then take the total number of nozzles on your system and multiply that by the specified gpm value. In our example, the system has 36 nozzles, so we enter a value of 7.2 (36 \* 0.2 gpm = 7.2 gpm) for the FLOW trip point. Assuming all nozzles are in good working condition (no clogs, worn, etc.), the secondary boom will automatically turn on when the total pressure reaches 40 psi.



### SPEED

If in Speed control, *SPEED* will display in the Rate display and miles per hour (or kilometers per hour) will be displayed in the Data display. If the Speed ever exceeds this trip point setting, then the Secondary Boom Enable output goes high. When the speed drops below the trip point, the Secondary boom will turn off.

\* **NOTE:** The SBE (Secondary Boom Enable) output always turns off when in HOLD.

### DISABLING THE ‘DUAL BOOM’ FEATURE

To disable Dual Boom control, you must enter ‘.00’ for both trip points (default setting from the factory). Be sure to press the CAL button a few times (right display toggles between ‘FLD’ or ‘SPEED’) to verify that each is set to zero (left display shows “OFF”).

# Appendix L (cont)

## Secondary Boom Control

The following shows a sample illustration of a wiring configuration.

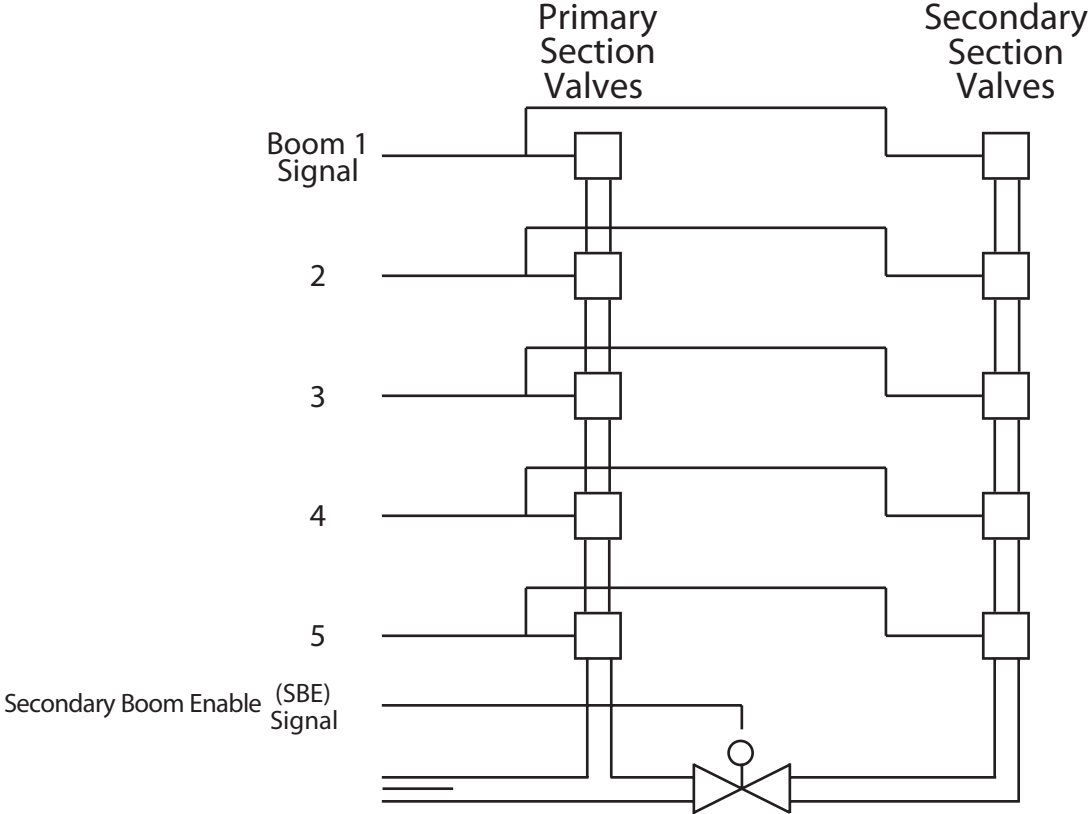

NOTE: Relief Wire is the VIOLET wire.

# Appendix M

## Conversion Chart

English to Metric		
When You Know	Multiple By	To Find
<b>LINEAR MEASUREMENT</b>		
inches	25.4	millimeters
feet	0.305	meters
yards	0.914	meters
miles	1.61	kilometers
<b>LAND MEASUREMENT</b>		
square inches	645.16	square millimeters
square feet	0.093	square meters
square yards	0.836	square meters
acres	.405	hectares
square miles	2.59	square kilometers
<b>LIQUID MEASUREMENT</b>		
fluid ounces	29.57	milliliters
pint	0.473	liters
quart	0.946	liters
gallons	3.785	liters
<b>VOLUME</b>		
cubic feet	0.028	cubic meters
cubic yards	0.765	cubic meters
<b>DRY MEASUREMENT</b>		
quart	1.101	liters
peck	8.810	liters
bushel	35.239	liters
<b>FUEL CONSUMPTION</b>		
10 miles per gallon = 4.25 kilometers per liter		

Metric to English		
When You Know	Multiple By	To Find
<b>LINEAR MEASUREMENT</b>		
millimeters	.039	inches
meters	3.28	feet
meters	1.09	yards
kilometers	.62	miles
<b>LAND MEASUREMENT</b>		
square millimeters	0.00155	square inches
square meters	10.764	square feet
square meters	1.195	square yards
hectares	2.47	acres
square kilometers	0.386	square miles
<b>LIQUID MEASUREMENT</b>		
milliliters	0.034	fluid ounces
liters	0.529	pint
liters	0.264	quart
liters	2.64	gallons
<b>VOLUME</b>		
cubic meters	35.314	cubic feet
cubic meters	1.307	cubic yards
<b>DRY MEASUREMENT</b>		
liters	1.101	quart
liters	8.810	peck
liters	35.239	bushels
<b>FUEL CONSUMPTION</b>		
10 kilometers per liter = 23.5 miles per gallon		

### Conversion Abbreviations

Symbols	Symbols	Symbols
in. = inches	pt. = pint	km = kilometers
ft. = feet	qt. = quart	mm <sup>2</sup> = square millimeters
yd. = yards	gal. = gallon	m <sup>2</sup> = square meters
mi. = miles	ft <sup>3</sup> = cubic feet	ha = hectares
in <sup>2</sup> = square inches	yd <sup>3</sup> = cubic yards	km <sup>2</sup> square kilometers
ft <sup>2</sup> = square feet	pk. = peck	ml = milliliters
yd <sup>2</sup> = square yards	bu. = bushel	l = liters
mi <sup>2</sup> = square miles	mm = milliliters	dal = dekaliters (10 liters)
fl oz. = fluid ounces	m = meters	m <sup>3</sup> = cubic meters



# Appendix N

## Replacement Parts List

The following replacement parts are available from your dealer or distributor. To find your nearest dealer or distributor, visit [www.micro-trak.com](http://www.micro-trak.com) or call Micro-Trak at 1-800-328-9613.

Micro-Trak Systems, Inc.  
 P .O. Box 99 • 111 East LeRay Avenue  
 Eagle Lake, MN 56024-0099

*When ordering parts, please list the model number of your console, and the description and part number of each part that you want to order.*

Part Number	Description
01189	Wireless Remote Kit
12069	Magnet kit (6 magnets per kit)
10013	Speed sensor mount bracket
12910	14" Black plastic cable ties (bag of 10)
13774	Console Mount Kit*
10423	Console Mount Knob
10470	Console Mount Washer
13096	5-foot Hall-effect Speed/Flow Sensor Cable with threaded sensor, nut and female connector
13226	5-foot Remote Run/Hold Sensor Cable
01531	Speed Sensor kit
14928	1" M-T Electric Servo Valve
11501	FM750 GFN Flowmeter
10131	FM750 SS Flowmeter
12274	FM1500 SS Flowmeter
14946	Reference Manual
13187	FM1000 SS Flowmeter
13269	FM500 Flowmeter
14286	FM270 Flowmeter
14829	FM10-100 Flowmeter
14366	NH3 System Adapter Cable
14318	Power and Boom Console Harness (Boom 120", Power Harness 240")
14320	Flow, Servo, Run/Hold and Relief Harness (120")
14403	Power Connection to EPD
14324	Bulkhead Speed Cable (36")
10899	FM750N Flowmeter, NH3 Only
14348	FM1500N Flowmeter, NH3 Only/Liquifier
14958	NH3500 Servo
14959	Liquifier Servo
17136	1" Flanged Servo
17140	1-1/2" Flanged Servo
21353	NH3 Servo Gearhead Assembly

Optional 2-Pin, 3-Pin and 10-Pin Metri-Pack 150 extension cables:

Part No.	M/P 2-Pin	Part No.	M/P 3-Pin	Part No.	M/P 7-Pin	Part No.	M/P 10-Pin	Part No.	W/P 3-Pin
13200	5-foot	13205	5-foot	14146	5-foot	13220	5-foot	10450	5-foot
13201	10-foot	13206	10-foot	14147	10-foot	13221	10-foot	10449	10-foot
13202	15-foot	13207	15-foot	14103	15-foot	13222	15-foot	10876	15-foot
13203	20-foot	13208	20-foot	14236	20-foot	13223	20-foot	10829	20-foot
13204	25-foot	13209	25-foot	14237	25-foot	13224	25-foot	11462	25-foot

**\*The Console Mount Kit is available only as a kit, some parts are not available in individual components.  
 Parts and design specifications subject to change without notice.**





MANUFACTURED IN U.S.A. BY:



111 E. LeRay Avenue • P.O. Box 99 • Eagle Lake, MN 56024-0099

Toll Free: (800) 328-9613  
(507) 257-3600 • Fax: (507) 257-3001

[www.micro-trak.com](http://www.micro-trak.com) • [trakmail@micro-trak.com](mailto:trakmail@micro-trak.com)  
© 2007 Micro-Trak Systems, Inc. • Printed in U.S.A.