

CROPLANDS PART NUMBERS: QJ17560A-20-NYB – TEEJET 20mm SPLIT EYELET NOZZLE BODY C/W NON-DRIP CHECK VALVE

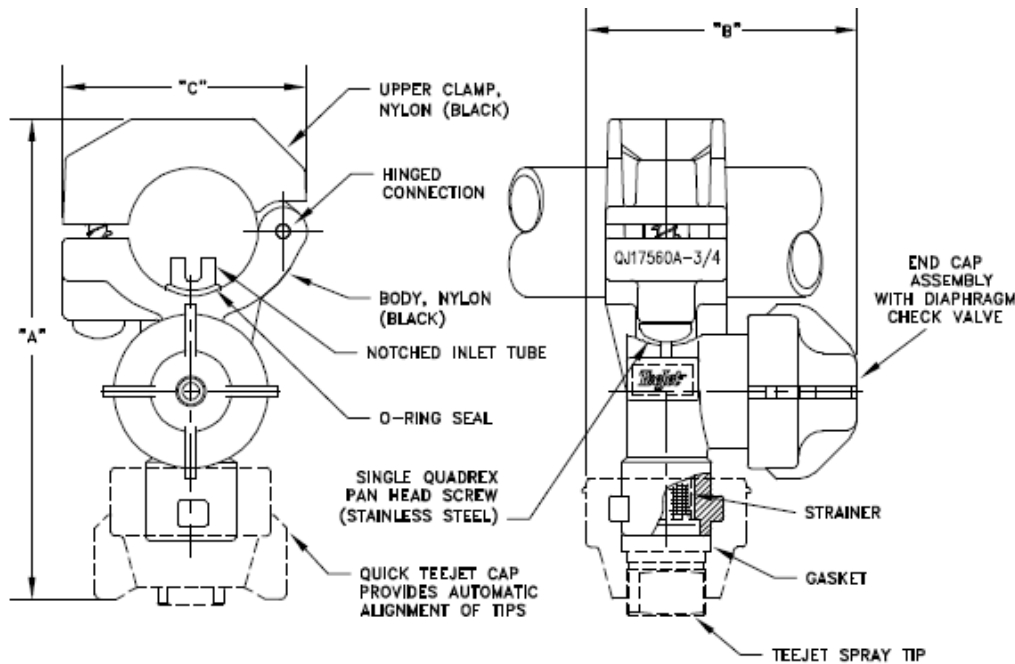

TO INSTALL ASSEMBLY DRILL 3/8" (9.5 mm) DIAMETER HOLE IN PIPE, DEBURR, THEN INSERT NOZZLE BODY INLET AND CLAMP ASSEMBLY IN PLACE.

BODY ASSEMBLY No.	"A"	"B"	"C"	TO CLAMP ON
QJ17560A-1/2-NYB	4" (102 mm)	2 3/16" (56 mm)	1 15/16" (49 mm)	1/2" Pipe
QJ17560A-3/4-NYB	4 1/16" (103 mm)	2 3/16" (56 mm)	2" (51 mm)	3/4" Pipe
QJ17560A-1-NYB	4 3/16" (106 mm)	2 3/16" (56 mm)	2 5/16" (59 mm)	1" Pipe
QJ17560A-20mm-NYB	3 15/16" (100 mm)	2 3/16" (56 mm)	1 7/8" (48 mm)	20mm O.D. Tubing
QJ17560A-25mm-NYB	4 1/16" (103 mm)	2 3/16" (56 mm)	1 15/16" (49 mm)	25 mm O.D. Tubing

Note: "A", "B", & "C" dimensions are approximate.

FEATURES:

- FAST AND EASY WAY TO MOUNT SPRAY NOZZLES TO BOOMS AND HEADERS.
- HINGED UPPER CLAMP REDUCES ASSEMBLY TIME.
- ALLOWS FOR QUICK CHANGE OF SPRAY TIPS.
- DRIP-FREE POSITIVE SHUT-OFF.
- NOTCHED INLET TUBE PREVENTS SEDIMENT BUILDUP IN BOOM.
- MADE OF CORROSION RESISTANT MATERIALS.
- STANDARD O-RING MADE OF BUNA-N. VITON O-RING OPTIONAL.
- STANDARD DIAPHRAGM MADE OF EPDM. VITON DIAPHRAGM OPTIONAL.
- STANDARD OPENING PRESSURE – 10 PSI (0.7 bar).
- MAXIMUM OPERATING PRESSURE – 300 PSI (20 bar).
- LOW PRESSURE DROP: 5 PSI AT 2.24 GPM (0.35 bar AT 8.5 l/mIn).
- HEX SOCKET IN CENTER OF UPPER CLAMP PERMITS ATTACHMENT TO FLAT SURFACE USING CUSTOMER SUPPLIED FASTENER.
- CLAMP ASSEMBLY WILL FIT INSIDE COMMON CHANNELS USED FOR SPRAY BOOMS.

HOW TO ORDER:

FOR DIAPHRAGM QUICK TEEJET BODY ASSEMBLY (DOES NOT INCLUDE CAP, GASKET, TIP OR STRAINER)

EXAMPLE: QJ17560A-1/2-NYB QUICK TEEJET NOZZLE BODY ASSEMBLY
 QJ17560A-1/2-NYB-VI QUICK TEEJET NOZZLE BODY ASSEMBLY
 (VITON DIAPHRAGM AND O-RING)

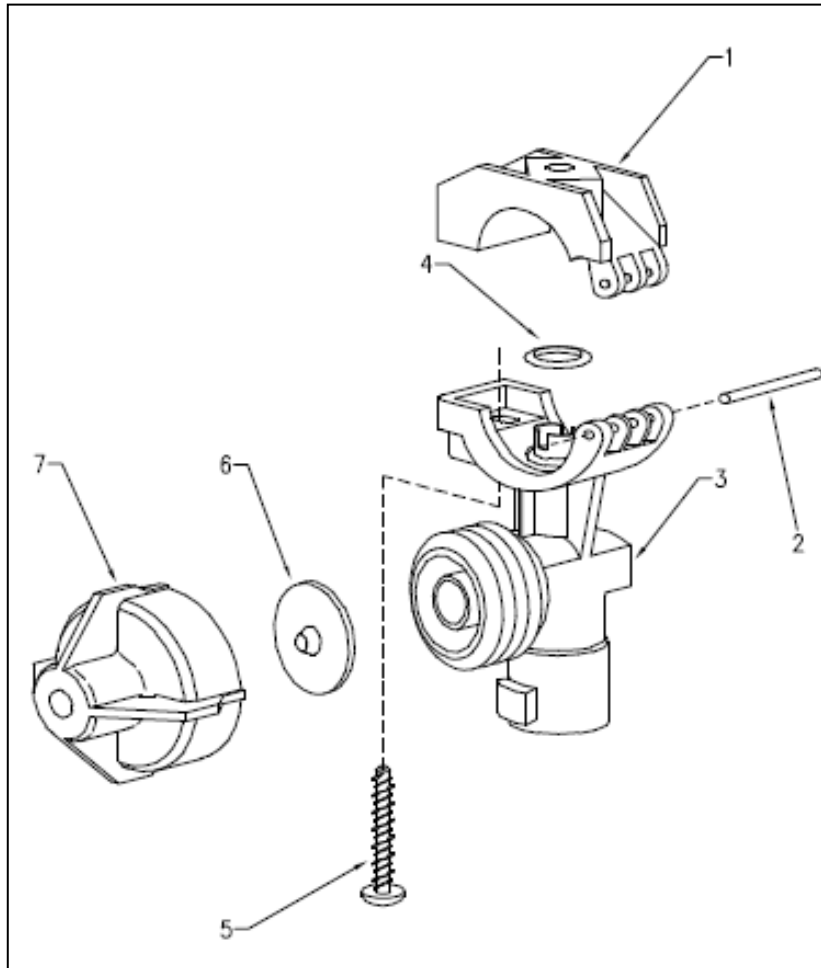

ITEM	PART NO.	DESCRIPTION
1	CP48223-NYB	Upper Clamp, 1/2", Nylon (Black)
	CP48221-NYB	Upper Clamp, 3/4", Nylon (Black)
	CP48222-NYB	Upper Clamp, 1", Nylon (Black)
	CP48220-NYB	Upper Clamp, 20mm, Nylon (Black)
	CP48224-NYB	Upper Clamp, 25mm, Nylon (Black)
2	CP48256-SS	Pivot Pin, Stainless Steel
3	CP48496-NYB	Body, 1/2", Nylon (Black)
	CP48498-NYB	Body, 3/4", Nylon (Black) (for 3/4" and 25mm versions)
	CP48499-NYB	Body, 1", Nylon (Black)
	CP48497-NYB	Body, 20mm, Nylon (Black)
4	CP7717-2/110-BU	O-Ring, Buna-N
	CP7717-2/110-VI	O-Ring, Viton (Optional)
5	CP48255-1 1/4-302SS	Screw, Stainless Steel
6	CP21953-EPR	Diaphragm, EPDM
	CP21953-VI	Diaphragm, Viton (Optional)
7	21950-10-NYB	End Cap Sub-Ass'y, Nylon (Black)
		No. QJ17560A-1/2-NYB(-VI) - Hinged Nozzle Body Assembly
		No. QJ17560A-3/4-NYB(-VI) - Hinged Nozzle Body Assembly
		No. QJ17560A-1-NYB(-VI) - Hinged Nozzle Body Assembly
		No. QJ17560A-20mm-NYB(-VI) - Hinged Nozzle Body Assembly
		No. QJ17560A-25mm-NYB(-VI) - Hinged Nozzle Body Assembly
		Note: -VI in part number specifies Viton material for parts #4 and 6