

## WEEDit **Wide swing arm** retrofit kits

**SPEC-5459S** (for a Steer wheel assembly). This kits comprise of,

- 1 @ AB243901-110B, **Swing Arm, Steering, Version 3.**
- 1 @ MP-394, **Retrofit shock mount pair L/R**
- 4 @ MP-393, **Retrofit bearing spacers**
- 1 @ RP-010, **Paint, flame red touch up**
- 2 @ M14 x 120 bolts
- 6 @ M14 x 65 bolts

**SPEC-5459C** (for a Castor wheel assembly). This kits comprise of,

- 1 @ AB243901-100B, **Swing Arm, Castor, Version 3.**
- 1 @ MP-394, **Retrofit shock mount pair L/R**
- 4 @ MP-393, **Retrofit bearing spacers**
- 1 @ RP-010, **Paint, flame red touch up**
- 2 @ M14 x 120 bolts
- 6 @ M14 x 65 bolts

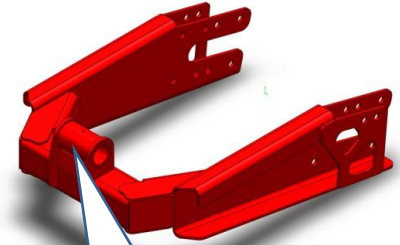

Castor version is wider here

**Retrofitting new v3 swing arm to original pivot / body.** The extra width of the v3 swing arm means that the shock absorber mounts are 60mm wider than the original pivot/body shock absorbers mounting position. Rework the shock absorber mounts by using the “retrofit shock mount”, MP-394 (supplied as a pair, LH & RH).

The original mounts need to be cut off and the new welded in place, as shown (fitted to Steer pivot/body) - note the offset.

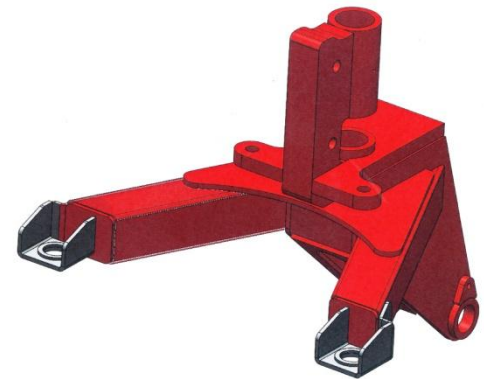

### Retrofitting old shaft into new v3 swing arm.

This can be done by using double (total of 4 required) MP-393 “Retrofit bearing spacers” installed between the swing arm and existing bearing block. Requires 1 @ M14 x 120 and 3 @ M14 x 65 bolts each side.

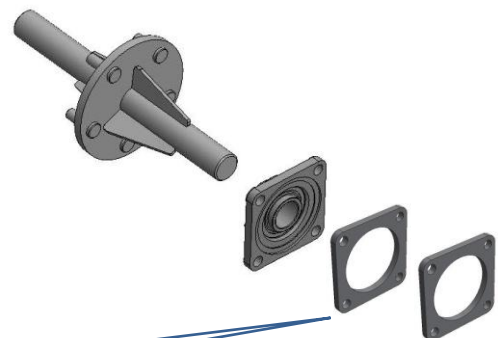

MP-393 (2 each side)