

ITEM NO.	PART NUMBER	DESCRIPTION	QTY.
1	2016 02 17 STEERING WHEEL PIVOT RETROFIT	TOP MOUNT	1
2	AB243901-110AS	UNIVERSAL SWING ARM	1
3	AB243903-100	AXLE CASTOR WHEEL	1
4	AB243906-100	BEARING AND HOUSING KIT 40X102	2
5	HP-202R	WHEEL 12Lx15 MULTI RIB 5/140	1
6	MP-391A	SHOCK ABSORBER W/ COIL HEAVY	2
7	MP-392	WHEEL NUT M16 X 1.5	5
8	MP-393	SPACER AXLE CASTOR WHEEL	4
9	AB243204-110	50MM PIN	1
10	AB243904-110	STEERING WHEEL SWING ARM PIN	1
11	AB243000-110A-8	PERMAGLIDE BUSH 50 X 40	2
12	AB243000-110A-9	PERMAGLIDE BUSH 50 X 60	2
13	AB243000-110A-7	PERMAGLIDE BUSH 40 X 40	2
14		M6 GREASE NIPPLE	3
15		M10 X 20 SET SCREW HT ZP	1
16		M10 SPRING WASHER ZP	1
17		M10 FLAT WASHER ZP	1
18		M14 FLAT WASHER ZP	16
19		M14 NYLOC NUT HT ZP	8
20		M14 X 120 BOLT HT ZP	2
21		M14 X 65 BOLT HT ZP	6

SUPPLY 2 PER BOOM

UNLESS OTHERWISE SPECIFIED: DIMENSIONS ARE IN MILLIMETERS SURFACE FINISH: ± 0.2 TOLERANCES: LINEAR: ± 0.5 ANGULAR: ± 0.5		FINISH: N/A	DEBUR AND BREAK SHARP EDGES	DO NOT SCALE DRAWING	ISSUE	A
DRAWN: LJSMITH CHKD: APPVD: MFG: Q.A:			SIGNATURE: DATE: 260215	REVISION:	<b>CROPLANDS</b> A NUFARM LIMITED COMPANY TITLE: <b>WEEDIT</b> RETROFIT STEERING WHEEL WITH INTERIM SWING ARM	
MATERIAL: N/A			DWG NO.:		<b>STEERING WHEEL</b> <b>FEBUARY 2016</b> A2	
WEIGHT:			SCALE: 1:10		SHEET 1 OF 3	

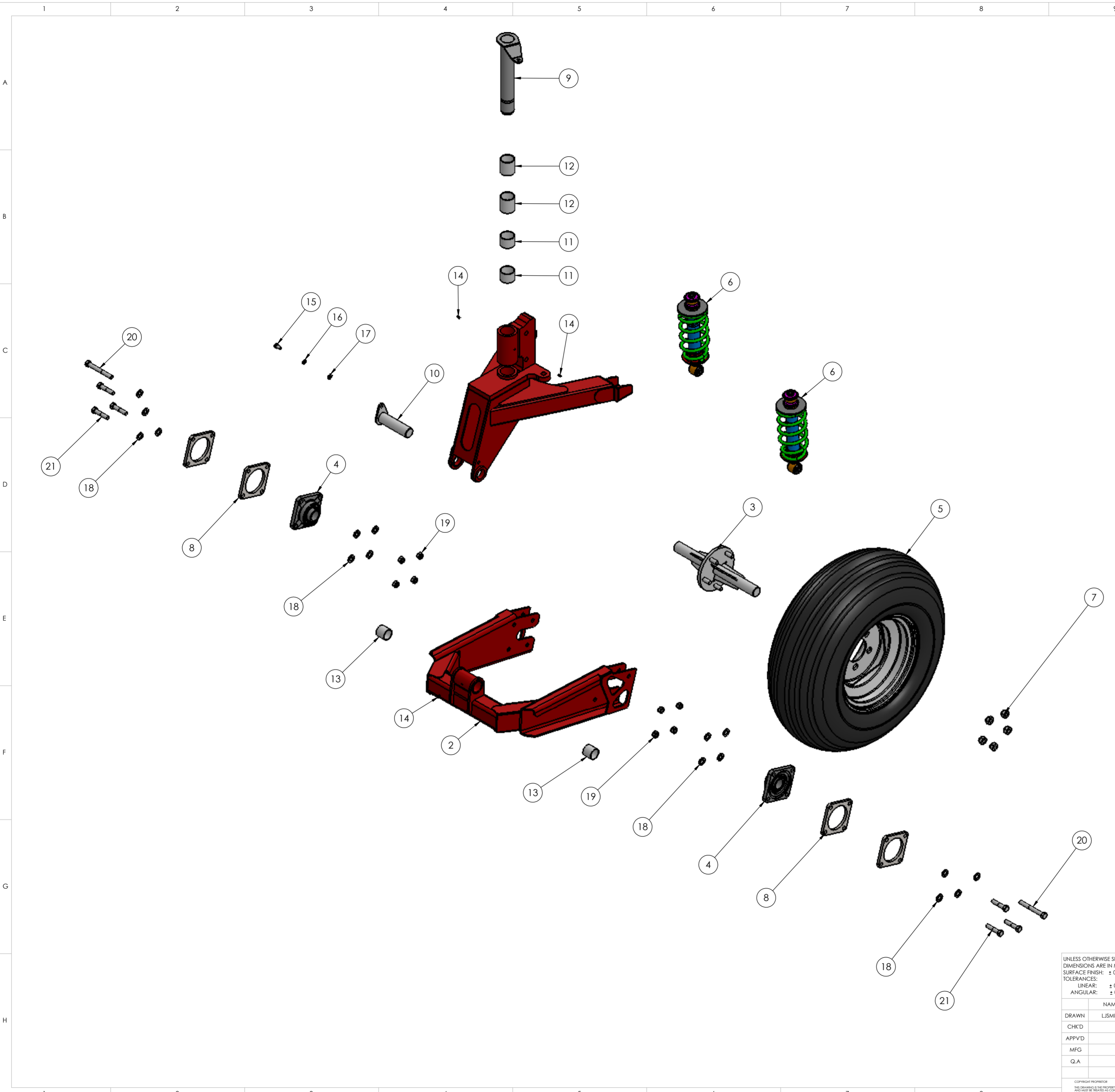

ITEM NO.	PART NUMBER	DESCRIPTION	QTY.
1	2016 02 17 STEERING WHEEL PIVOT RETROFIT	TOP MOUNT	1
2	AB243901-110B	UNIVERSAL SWING ARM	1
3	AB243903-100	WEEDIT BOOM SUSPENSION AXLE	1
4	AB243906-100	40MM BEARING 102MM MOUNTING HOLES	2
5	HP-202R	WHEEL 12Lx15 MULTI RIB 5/140	1
6	MP-391A	SHOCK ABSORBER HI RISE W/COIL	2
7	MP-392	WHEEL NUT M16 X 1.5	5
8	MP-393	RETROFIT BEARING SPACER	4
9		50MM PIN	1
10		STEERING WHEEL SWING ARM PIN	1
11		PERMAGLIDE BUSH 50 X 40	2
12		PERMSGlide BUSH 50 X 60	2
13		PERMAGLIDE BUSH 40 X 40	2
14		M6 GREASE NIPPLE	3
15		M10 X 20 SET SCREW HT ZP	1
16		M10 SPRING WASHER ZP	1
17		M10 FLAT WASHER ZP	1
18		M14 FLAT WASHER ZP	16
19		M14 NYLOC NUT HT ZP	8
20		M14 X 120 BOLT HT ZP	2
21		M14 X 65 BOLT HT ZP	6

SUPPLY 2 PER BOOM

UNLESS OTHERWISE SPECIFIED: DIMENSIONS ARE IN MILLIMETERS SURFACE FINISH: ± 0.2 TOLERANCES: LINEAR: ± 0.5 ANGULAR: ± 0.5		FINISH: N/A	DEBUR AND BREAK SHARP EDGES	DO NOT SCALE DRAWING	ISSUE	A
DRAWN: LJSMITH DATE: 260215			SIGNATURE	REVISION	TITLE: <b>WEEDIT</b> RETROFIT STEERING WHEEL WITH NEW SWING ARM	
MFG			MATERIAL: N/A		DWG NO.	STEERING WHEEL FEBRUARY 2016
Q.A			WEIGHT:		SCALE: 1:10	SHEET 2 OF 3

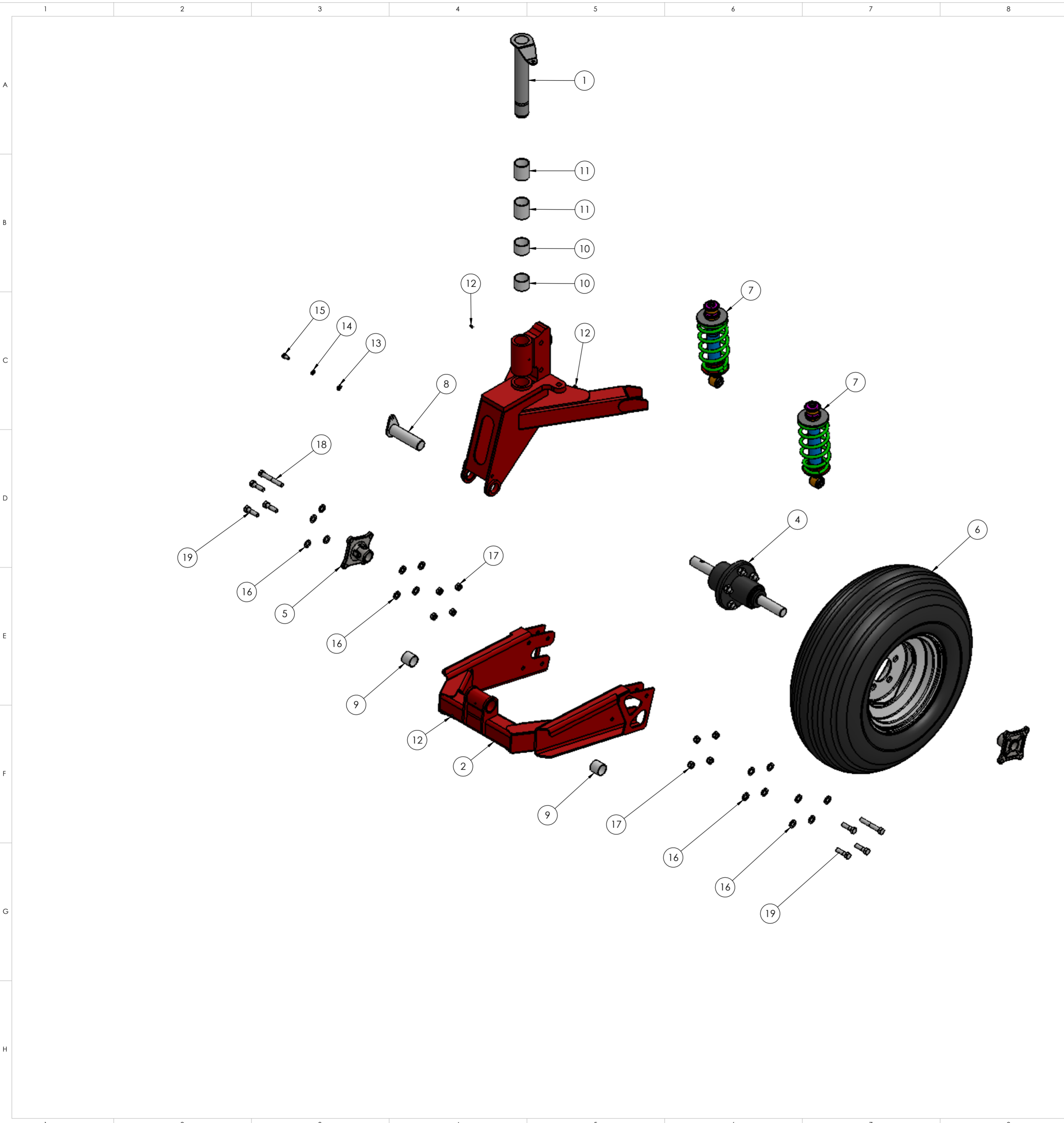

ITEM NO.	PART NUMBER	DESCRIPTION	NEW ASSEMBLY/ QTY.
1	AB243204-110	50MM PIN	1
2	AB243901-110B	UNIVERSAL SWING ARM	1
3	AB243902-110B	TOP MOUNT	1
4	BP-700C-16	TITAN AXLE WITH HUB	1
5	CAST AXLE MOUNT		2
6	HP-202R	WHEEL 12Lx15 MULTI RIB 5/140	1
7	MP-391A	SHOCK ABSORBER HI RISE W/COIL	2
8		STEERING WHEEL SWING ARM PIN	1
9		PERMAGLIDE BUSH 40 X 40	2
10		PERMAGLIDE BUSH 50 X 40	2
11		PERMAGLIDE BUSH 50 X 60	2
12		M6 GREASE NIPPLE	3
13		M10 FLAT WASHER ZP	1
14		M10 SPRING WASHER ZP	1
15		M10 X 20 SET SCREW HT ZP	1
16		M14 FLAT WASHER ZP	16
17		M14 NYLOC NUT HT ZP	8
18		M14 X 100 BOLT HT ZP	2
19		M14 X 50 BOLT HT ZP	6

SUPPLY 2 PER BOOM

UNLESS OTHERWISE SPECIFIED: DIMENSIONS ARE IN MILLIMETERS SURFACE FINISH: ± 0.2 TOLERANCES: LINEAR: ± 0.5 ANGULAR: ± 0.5		FINISH: N/A	DEBUR AND BREAK SHARP EDGES	DO NOT SCALE DRAWING	ISSUE	A
DRAWN LJSMITH			SIGNATURE	DATE 260215	REVISION	
CHKD						
APPVD						
MFG						
Q.A						
MATERIAL: N/A			DWG NO. STEERING WHEEL FEBUARY 2016		A2	
WEIGHT:			SCALE: 1:10		SHEET 3 OF 3	

COPYRIGHT PROPRIETOR  
ALL RIGHTS RESERVED. THIS DRAWING IS THE PROPERTY OF CROPLANDS PTY. LTD.  
REPRODUCTION OF THIS DRAWING FOR PARTS PURPOSES OR COMMUNICATION OF ITS  
CONTENTS IS PROHIBITED WITHOUT THE CONSENT OF CROPLANDS PTY. LTD.