

Croplands Operators Manual – Fire-fighter

Models:

400 litre – US400/FF

800 litre – US800/FF

1100 litre – US1100/FF



Introduction

Croplands Equipment is a subsidiary of Nufarm Australia Ltd and operates as Croplands Equipment Pty Ltd in Australia and Croplands Equipment Ltd in New Zealand. Croplands are a leading importer, manufacturer and supplier of spraying equipment primarily to the New Zealand and Australian markets, with expanding sales into the USA and Europe. Established in 1972, Croplands is one of the four largest suppliers, with the largest range, of spraying equipment to the Australasian market.

This manual covers the Croplands' range of firefighter units with a tank capacity of 400, 800 & 1100 litres.

Manufactured to a high standard, every effort has been made to ensure the unit can be used correctly and with customer satisfaction. As the owner of a Croplands unit, please read this manual thoroughly to fully familiarise yourself with all aspects of the safe and correct operation of your firefighter. Maintenance information and useful tips have been noted so please use these to get the best from your unit.

Should you need any support or advice on the set up and use of your firefighter, contact your local Croplands dealer or contact Croplands Customer Support.

Croplands Dealers are listed on www.croplands.com.au under "dealers" in the menu

Croplands can be contacted in Australia on 1800 999 162, and in New Zealand on 0800 106 898.

No liability can be accepted for any inaccuracies or omissions in this publication, although due care has been taken to make it as complete and accurate as possible.

The information, illustrations and technical data were considered to be correct at the time of preparation.

In accordance with our policy of continuous development, Croplands Equipment Pty Ltd reserves the right to make changes at any time without notice.

Contents

1. Warranty Policy	4
2. Warranty Registration & Pre Delivery Check List	5
3. Rules for Safe Operation	6
4. Specifications	6
5. Operation	6
6. Lubrication and Maintenance	8
7. Parts List	9

About Your Warranty

Croplands Equipment Pty Ltd will honour any warranty repair in line with the policy outlined on the following page. The following information will assist you in understanding our warranty procedures.

Any authorised Croplands Dealer or service outlet can perform warranty repairs, however we recommend that the Dealer or Reseller from whom you bought the machine carry out any such repairs.

Most warranty repairs are handled routinely, but sometimes requests for repairs cannot be accepted under warranty. Normal wear and tear is not covered by warranty nor does warranty apply if a machine fails prematurely and that failure can be attributed to abuse or neglect.

Whilst Croplands will abide by its warranty policy under all genuine circumstances, we must emphasise that such can only apply when our equipment has been used in applications for which it was designed and manufactured and that a reasonable degree of care and common sense has been exercised by the operator.

Warranty Repair Site

The warranty provides for repairs to be carried out at the servicing dealer's normal place of business. An owner may elect to have repairs carried out at his own residence, but whilst Croplands will accept the actual repair cost of the failed component(s), the travelling costs will not be covered under warranty.

Items Not Covered By Warranty

The warranty does not allow for the cost of the following items. ***These are the responsibility of the owner.***

1. Labour to travel to and from a breakdown or for any distance charges
2. Labour premiums that might apply for any repairs that are made outside the dealer's normal business hours
3. Transportation costs of the machine to and from the service outlet
4. Freight costs of the machine to and from the service outlet
5. Telephone or fax calls made by the owner in connection with the repairs

1. Warranty Policy

Croplands Equipment Pty Ltd (trading as Croplands) warrants to its authorised Dealer, who in turn, warrants to the original purchaser (Owner) that each new Croplands' firefighter, part or accessory will be free from proven defects in material and workmanship for twelve (12) months after delivery to the first Owner according to the conditions outlined.

This warranty does not cover damages resulting from abuse, accidents, alterations, normal wear or failure to maintain or use the Croplands product with due care.

During the warranty period, the authorised Croplands Dealer shall repair or replace, at Croplands option, without charge for parts and labour any part of the Croplands product, which fails because of defects in material or workmanship. The Owner must provide the authorised Dealer with prompt written notice of the defect (within 14 days of its occurrence), and allow reasonable time for replacement or repair.

Croplands (at its option) may request failed parts to be returned to the factory. Any travel time of a service technician and/or transportation of the Croplands product to the authorised servicing Dealer for warranty work are the responsibility of the Owner.

This warranty is in lieu of all other warranties (except those of title), expressed or implied, and there are no warranties of merchantability or fitness for a particular purpose. In no event shall the authorised selling Dealer or Croplands be liable for down time expenses, loss of machine use or other incidental, consequential or special damages.

Conditions of Warranty

1. The warranty is not transferable.

2. The Warranty Registration Form must be returned to Croplands by the Owner Operator within 14 days of taking delivery of the unit. Only when warranty registration is completed and returned, can Croplands fulfill all warranty obligations.

3. Components and conditions not covered by warranty are:

Abuse	Failure resulting from neglect, such as improper operation, lack of required maintenance or continued use of a unit after the discovery of a defect which results in greater damage to the unit.
Environmental Conditions and Application	Deteriorated or failed components such as: diaphragms, O-rings, hoses, seals, electrical wiring and connections damaged by corrosive chemicals, dirt and sand, excessive heat or moisture. Owners should ensure the water quality is compatible with the design of the unit. Warranty determination for these types of failures will be made by Croplands only after inspection of failed components. In most instances these will incur inspection charges and cost of replacement parts.
Normal Wear	Normal wear and consumable items such as: oils and lubricants, diaphragms, filter elements, pivot pins, paint, light bulbs etc are considered to be normal wear items and are not warranted.
Maintenance	Component failure caused by not performing scheduled maintenance service such as: oils, grease, failure to clean tanks, pumps, any filters, hoses, nozzles or any other blocked components. Not tightening or replacing loose or missing bolts, nuts, fittings, shields and covers.
Damage	Damages or machine failure caused by carelessness or accidental damage, improper operation, inappropriate transportation or storage of the fire fighter or attachment.
Alterations	Any unauthorised alteration, modification, attachments or unauthorised repairs to the Croplands fire fighter or attachments. Written approval must be obtained from Croplands for any such items to maintain warranty.
Removal & Installation	The time taken to remove and re-install a warranted part or component into other brands of firefighters will not be covered by Croplands warranty. Only parts and labour directly attributable to the repair of the Croplands unit is covered.
Clean-up Time	Croplands do not pay for cleaning the unit, parts, accessories or work area before or after the warranty repair. Clean-up time is affected primarily by the application or conditions in which the unit is operated and maintained. Since clean-up time can be so variable, cleaning time should be considered a customer expense.
Transportation	Warranty does not cover transportation or insurance costs for firefighters or other equipment needing repair or replacement of warranted components. Nor does it cover any freight or insurance costs in obtaining new parts or returning old parts to Croplands for inspection purposes.
Costs	Warranty does not cover time required to diagnose a warranty problem. Diagnostic time is affected greatly by the training and expertise of the technician employed to do the job. With proper training of service personnel, diagnostic time should be at a minimum.
Diagnostic Time	Croplands expect that Dealers will assign a well-trained and proficient technician to handle any warranty repairs. Since Croplands is not in control of either of these responsibilities, we elect not to cover diagnostic time.
Non-Genuine Parts	Use of parts other than Croplands parts for repair of warranted parts will automatically negate any warranty. Warranted components must be replaced with genuine Croplands, Davey or Honda repair parts.
Unauthorised Repairs	Repairs by an unauthorised agent will automatically forfeit any warranty. An authorised Croplands, Davey or Honda Dealer must carry out warranty repairs.

2. Warranty Registration & Pre Delivery Check List

Warranty Policy:

The Warranty Registration Form must be returned to Croplands by the Owner Operator within 14 days of taking delivery of the unit. Only when warranty registration is completed and returned, can Croplands fulfil all warranty obligations.

The warranty policy commences with installation. The warranty period is 12 months under normal conditions (6 months for contractors).

This **form must be completed by both Owner and Dealer**, and the original returned by the Dealer to Croplands. (Dealer and customer should keep a copy).

Date Purchased: Serial Number:.....

Tick Each box to affirm completion	✓	Tick Each box to affirm completion	✓
Operators manual supplied		Suction lines	
Firefighter pump (Davey)	<input type="checkbox"/>	- Undamaged	<input type="checkbox"/>
Firefighter unit (Croplands)	<input checked="" type="checkbox"/>	- Hoses not rubbed or kinked	<input type="checkbox"/>
Honda Motor (Honda)	<input type="checkbox"/>	- All joins sealed	<input type="checkbox"/>
Tank		Pressure lines	
- Inserts secure	<input type="checkbox"/>	- Undamaged	<input type="checkbox"/>
- Drain plug inserted	<input type="checkbox"/>	- Hoses not rubbed or kinked	<input type="checkbox"/>
- Undamaged	<input type="checkbox"/>		
- Check lid seals correctly	<input type="checkbox"/>		
Hose Reel		Pump	
Undamaged	<input type="checkbox"/>	- Check mounts	<input type="checkbox"/>
Check operation	<input type="checkbox"/>	- Check operation	<input type="checkbox"/>

Important:

By executing this Installation & Warranty Certificate:

1. The Owner:

- 1.1 Agrees that all Sprayer operators must read the Operator's Manual before using the Sprayer and follow all the procedures in the manual for the use of the Sprayer, and will exercise due care in the use of the Sprayer;
- 1.2 Agrees that Croplands' liability for any loss or damage suffered by the owner in connection with the owner's use of the Sprayer is limited to the cost of repair or replacement of the Sprayer;
- 1.3 Agrees that the owner will bear any loss the owner suffers as a consequence of any failure by the owner to comply with 1.1 above;
- 1.4 Acknowledges that the owner is trained and is fully responsible for the safe and correct operation of the Sprayer;
- 1.5 Agrees that the owner will fully train any person who is required to operate the Sprayer, as to how to operate the Sprayer in a safe and correct manner.

2. The Dealer: undertakes that it has met the obligations of installation, service and warranty start up.

<p>Owner: Farmer <input type="checkbox"/> Contractor <input type="checkbox"/> Name (Print): Address: Postcode:..... Phone: Fax: Email: Owner's Signature: Installation Date:</p>	<p>Dealer: Dealership Name (Print): Address: Postcode:..... Phone: Fax: Email: Dealer representative's Name: Dealer representative's Signature: Date:</p>
---	--

3. Rules for Safe Operation

- Always read your operator's manual thoroughly before operating. Accidents occur every year because of careless use of farm machinery. You can avoid these hazards by observing these safety instructions.
- Inspect hose and hose connections daily.
- When working on your unit, always stay out from under it unless it is resting on the ground or supported on solid blocks. Hydraulics or jacks could fail letting the unit fall. This could result in pinning or crushing of personnel.
- Check the entire fire fighter, prior to each use, for any loose bolts or mechanical connections. These precautions can prevent injury to personnel and damage to equipment.
- Use only genuine Croplands, Honda or Davey parts for any necessary replacement. All parts are important to the equipment design. Homemade parts may look the same but might be dangerous in operation.
- Always be sure all guards are properly installed on machine before operating. Failure to do so could result in entanglement in moving parts resulting in serious injury to operator.
- Do not disconnect any hoses while unit is operating.
- Should any welding be required on the steel parts of the fire fighter, always clean the unit and disconnect the power before doing any repairs. Cover rubber hoses, and all other flammable parts. Keep a fire extinguisher near the unit when welding. Have good ventilation when grinding or welding painted or galvanised parts. Wear dust mask when grinding. Toxic dust or gas can be produced.



4. Specifications

<p>Tank Constructed from UV-stabilised medium density polyethylene for low distortion qualities & impact resistance. 10mm threaded Brass inserts for mounting pump and hose reel. Capacity of 400 or 800 litres with calibrated level indicator. Screw down lid</p> <p>Pump Davey single impellor "firefighter" model 5155H pump. For specs see pages 10 & 11.</p>	<p>Hose reel Steel construction, fitted with 36 metres of 20mm diameter hose and an adjustable firefighter nozzle.</p> <p>Drive Honda GX160 pull-start engine direct coupled to the Davey Pump For more detail see Honda Manual.</p>
--	--

5. Operation

<p>Operation:</p> <p>Fill unit with clean water from a suitable source. If filling the tank through the lid, ensure that the basket strainer is in place and is clean. Close the lid securely after filling.</p> <p>Before operation, check the oil in the engine, and from time to time check the air-filter to avoid problems with the unit in times of emergency. READ THE HONDA MANUAL THOROUGHLY TO FAMILIARISE YOURSELF WITH MAINTENANCE PROCEDURES.</p>	<p>Starting the Firefighter</p> <p>When starting the unit for the first time, conduct a trial run to familiarise yourself with the operation of the components and to check that all systems are functioning correctly without any leaks.</p> <p>Ensure the main tank tap is open. Pull start the engine and set the throttle to ¾ RPM. Open the firefighter nozzle and aim the water stream at the required object or fire source.</p> <p>Use the adjustable nozzle to adjust the liquid stream as required.</p> <p>FOR MORE DETAILED INFORMATION, SEE THE PICTORIAL SEQUENCE BELOW.</p>
--	---

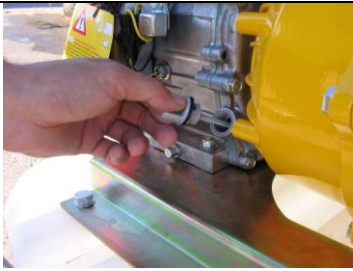
Pictorial Operation Chart

		
<p>1. If filling the firefighter through the lid, unscrew as in pictures 1 & 2.</p>	<p>2. Lid unscrewed</p>	<p>3. Check main tank tap (shown in closed position) then switch to open from tank (downwards).</p>
		
<p>4. Turn off fill tap</p>	<p>5. Check engine oil level before starting engine – Note – also check fuel. See “maintenance” for further information.</p>	<p>6. If spraying from external source turn tank tap upwards while leaving fill tap closed.</p>
		
<p>7. Start engine and adjust throttle to $\frac{3}{4}$ speed</p>	<p>8. Aim nozzle and adjust accordingly</p>	<p>9. Have your external filling line ready</p>
		
<p>10. Fit external line with Camlock.</p>	<p>11. Turn Main tank tap to external source (upwards as shown)</p>	<p>12. Turn fill tap on. Taps should now be as shown.</p>
		
<p>13. Close the firefighter nozzle prior to external filling.</p>	<p>14. Put the filling line inlet strainer fully underwater or into the water source so it cannot suck air</p>	<p>15. By turning fill tap off spray can be used directly from external source.</p>

Note:

The firefighter can be operated with the external suction line drawing water from a pond, stream, swimming pool or tank. This will mean however, that the unit is NO LONGER PORTABLE. ***This may only be an appropriate use of the firefighter if portability is not required.***

6. Lubrication and Maintenance

Each component of the Croplands firefighter has its own maintenance instructions which are supplied with the unit.

For the **Davey Pump**, please read the small booklet titled "INSTALLATION AND OPERATING INSTRUCTIONS". In this booklet you will find valuable information such as:

- Suction and delivery pipe specifications and tips
- Pump priming instructions and tips
- Operational instructions
- How to avoid pump damage
- Storage of the pump
- Davey contact information

For the **Honda Motor**, there is a comprehensive booklet covering all parts, operational instructions and safety tips. Keep this with your firefighter or in handy location for reference.

For the **Croplands** components of the firefighter, basic instructions are:

- Store the unit out of the sun to avoid tank cracking & UV damage
- Check all mounting bolts for tightness annually
- Check all hoses & seals before the fire season
- Check all taps and the nozzle regularly
- Test the unit before each season
- During the fire season, keep the unit full of water, ready to go. Ensure the motor is fully fueled at all times. At all other times, drain the unit for storage
- Replace any faulty parts immediately
- Keep instruction booklets handy to the unit

Basic maintenance:

- Run the motor and pump every month to maintain seals, and ensure it operates when required.
- Never run the pump dry for any length of time, and do not run for too long without the nozzle discharging as this will cause water in the pump to get dangerously hot and will damage the pump seal
- Check the Honda motor oil level and air-cleaner regularly
- Lubricate o-rings or seals from time to time as required
- Keep the unit clean
- Use clean water during operation – or at least as clean as possible

Repairs

In most cases, repairs are likely to be to the pump or motor. There are Honda and Davey agents all over Australia. To facilitate quick repair, it is recommended you contact your local DAVEY pump or HONDA motor agent for parts or repairs.

7. Parts List

Part Number	Description	Qty.
P400-RAW P800-RAW P1100-RAW	TANK 400L, 800L, 1100L FREE STANDING POLY RAW	1
UP-171	PUMP MOUNTING BRACKET 200/400/800	1
UP-172	HOSEREEL BRACKET 200/400/800	1
A509104	GROMMET PIPE 44X36X18	2
FF-PUMP	PUMP / MOTOR FIREFIGHTER 5HP	1
UP-410	HOSE KIT FIRE FIGHTING	1
SW502-001C	TANK LID ASSY RED	1
L-R0260BARE	H_REEL 50MTR SIDE MOUNT BARE	1
K-150-C	CAMLOCK 1½" HOSE SHANK "C" P	1
AB158	REEL SWIVEL ¾"	1
TR112HC	HOSE CLAMP 40mm 1½" WORM DRI	3
HEP40	HOSE 40mm SUCTION (BLACK)	2
K-150-CAP	CAMLOCK 1½" CAP "DC" POLY GL	1
A-A3434	HOSEBARB ¾" BSPM X ¾" BARB	1
TR34HC	HOSE CLAMP 20mm ¾" WORM DRIV	2
A454136	VALVE BALL POLY 1½" 2 WAY	1
A250060	NIPPLE 1½"	2
A116640	ELBOW 1½"	1
A106640	TAIL 1½" TO 40mm	1
A200060	FLY NUT 1½"	2
AG10061	O RING 1½"	2
A1262066	ELBOW 1½" MALE FEMALE	1
K-150-F	CAMLOCK 1½" MALE THREAD "F"	1
A454236	VALVE BALL POLY 1½" 3 WAY	1
HPW20	HOSE 20mm	2
TFEL3434MF	ELBOW ¾" BSPM X ¾" BSPF	1
A1262044	ELBOW 1" X 1" MALE/FEMALE	1
A106422	TAIL 1" TO 22mm	1
A200040	FLY NUT 1"	1
AG10041	O RING 1"	1

SINGLE IMPELLER "FIREFIGHTER"[®]
Model Numbers: 5155H, 5160B,
5165H & 5165HE

DEPEND ON
DAVEY

WATER PRODUCTS

SELF PRIMING PUMPS

PRODUCT DESCRIPTION

Rugged, economical single impeller self priming pump. These units are driven by either a 6hp Briggs & Stratton "Vanguard" engine, a 5.5hp Honda GX160 engine or a 6.5hp Honda GX200 engine. The GX200 engine is also available in electric start.

APPLICATIONS

- Firefighting
- Tanker to tanker water transfer
- High head general water transfer
- Sheep jetting
- Irrigation
- Boom spraying



FEATURES & BENEFITS

Patented clamped impeller design to enable longer impeller life, improved performance and easier disassembly in the case of blockage.

Single impeller design provides the versatility of high flow rates with strong pressure.

Thrust balanced impeller design to extend engine life.

Pump casing, diffusers and impellers manufactured from quality corrosion resistant marine grade aluminium for long life.

4 way discharge port for easy installation with a choice of plumbing sizes.

Polyester coated pump casing, exterior and interior, for added corrosion resistance.

Patented floating impeller neckrings front and back. The front neckring helps improve pumping efficiency, the back neckring helps extend seal life and dramatically reduce engine wear.

Self priming from 7m for more versatile installation options.

Large priming and drain port with bayonet fit plugs. Plugs have safety retention system, plus are available with 1/4" tapping to accept pressure gauges or drain cocks.

Low-oil protection on all models - engines won't start or run if oil level is inadequate, thus protecting your engine.

All engines feature cast iron cylinder bore for long life.

Electric start models have electric starter (battery and leads required) and recoil starter fitted, ensures a choice of starting methods, even if the battery is flat or removed.

Viton seal and oring kit available for herbicide/insecticide spraying.

All engines conform to the tough environmental requirements of the USA EPA and CARB standards, to help look after the environment.

OPERATING LIMITS

Flows to	500lpm
Maximum total head	72m
Maximum suction Lift	7m
Maximum water temperature	50°C
Minimum water temperature	1°C
Maximum casing pressure	1000kPa
Minimum suction pipe size	1 1/2"
Suction pipe strainer	Required
Inlet size	1 1/2" BSP(M)*
Outlet sizes	2 x 1 1/2" BSP(M)*

TECHNICAL SPECIFICATIONS

MATERIALS OF CONSTRUCTION

PART	MATERIAL
Suction cover	Marine grade aluminium (AS605)
Diffuser	Marine grade aluminium (AS605)
Impeller	Marine grade aluminium (AS605)
Casing / yoke	Marine grade aluminium (AS605)
Mechanical seal	Carbon / ceramic
4 way discharge	Marine grade aluminium (AS605)
Casing bolts	Zinc plated steel
Yoke bolts	Stainless steel
Flap valve / seal ring	Zinc body, Hytrel seal
Neck ring, priming & drain plug	Glass filled Nylon
Casing, priming & drain plug O-ring	Nitrile rubber
Discharge gasket	Hytrel
Paint finish	Baked polyester powder coat

ENGINE SPECIFICATIONS

Single Stage Pump Model	5155H	5165H	5165HE	5160B
Engine Brand	Honda			BB5
Engine Model	GX160	GX200	GX200E	Vanguard
Engine Type	Overhead Valve			
Max. HP @ 3600 rpm	5.5	6.5	6.5	6.0
Displacement (cc)	163	196	196	182
Fuel Tank (litres)	3.6	3.6	3.6	4
Oil Capacity (litres)	0.6	0.6	0.6	0.7
Compression Ratio	8.5:1			
Air Filter Type	Dual stage - foam prefilter with paper element final filter			
Spark Arrestor	NO	NO	NO	YES
Approx. fuel consumption @ full load @ 3600 rpm	1.73l/hr	2.05 l/hr	2.05 l/hr	1.93 l/hr
dBa @ 4m @ 3600 rpm @ full load	85	86	86	75

INSTALLATION & PRIMING

- Fit strainer to bottom of suction pipe; a foot valve is not required
- To prime, fill pump body with water then allow pump to run until drawing water

This literature is not a complete guide to product usage. Further information is available from your Davy dealer, Davy Customer Service Centre and from the relevant product installation and operating instructions. This data sheet must be read in conjunction with the relevant product installation and operating instructions and all applicable statutory requirements. Product specifications may change without notice. © Davy and Firefighter are registered trademarks of Davy Products Pty Ltd. © Davy Products Pty Ltd 2004.

HYDRAULIC PERFORMANCE

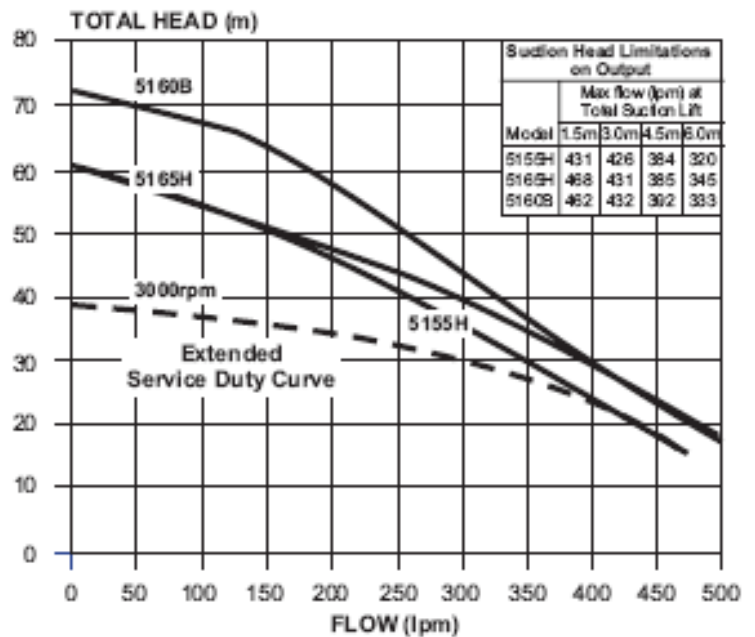

DIMENSIONS

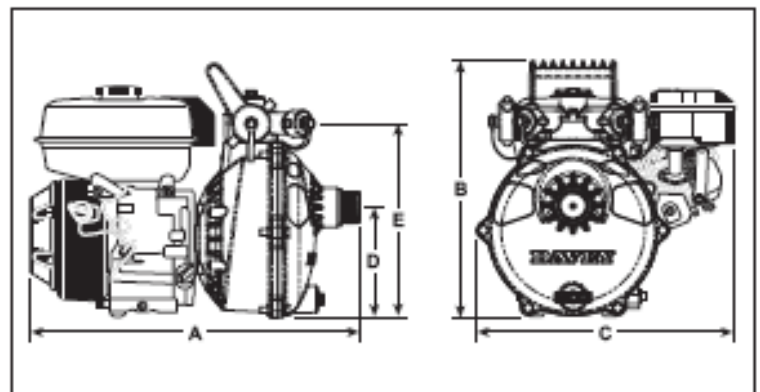

Model	A	B	C	D	E	Inlet BSP	Outlet BSP	Net Weight kg.
5165H 5165HE	510	388	402	169	296	1 1/2" M	2x1" M 2x1 1/2" M	22 22.5
5155H	445	388	388	169	296	1 1/2" M	2x1" M 2x1 1/2" M	21
5160B	535	388	395	169	296	1 1/2" M	2x1" M 2x1 1/2" M	25.5

All dimensions in mm unless otherwise stated.

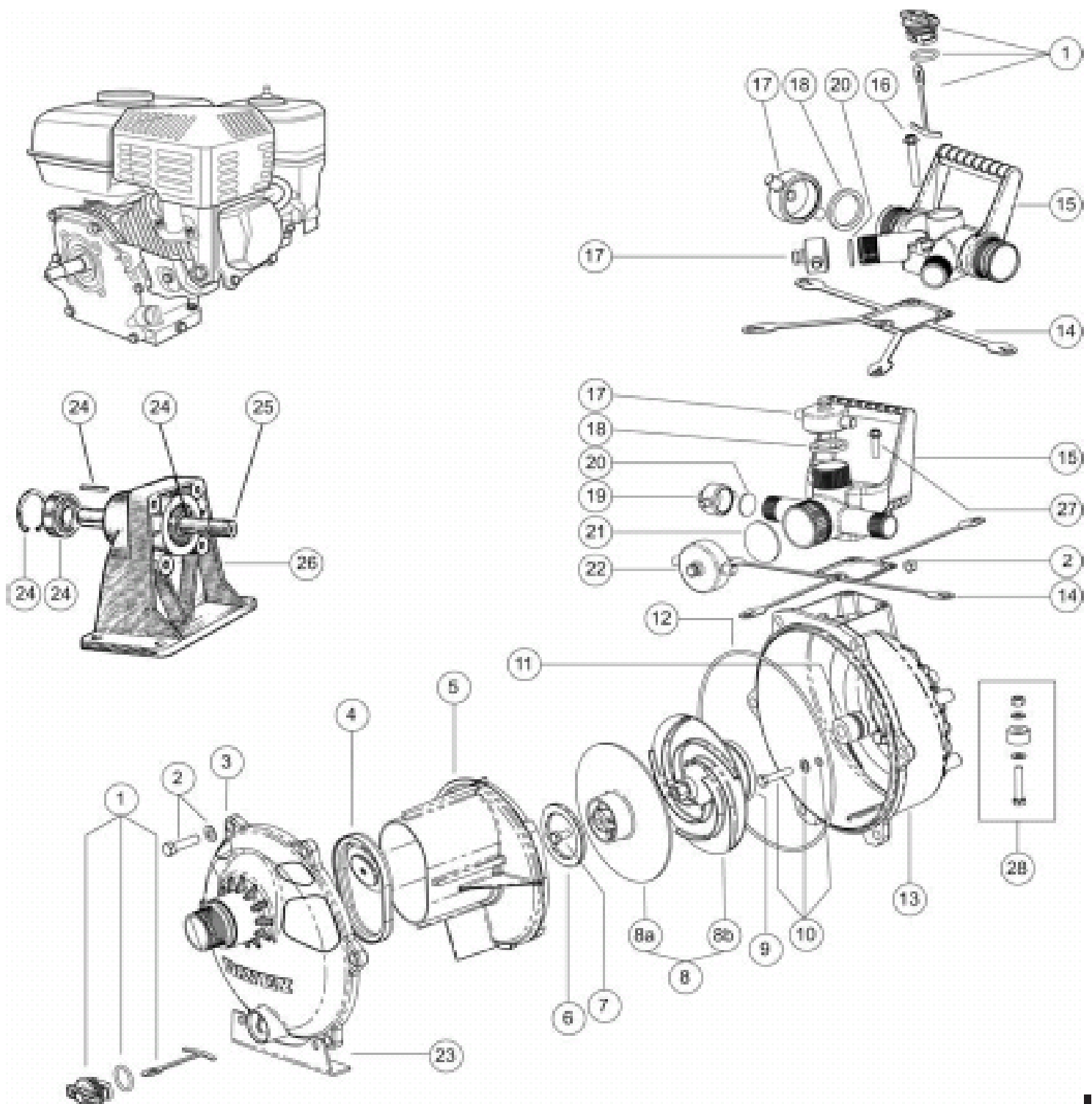

ENGINE POWERED SELF PRIMING PUMPS (CONTINUED)

ITEM	NOTES	DESCRIPTION	QTY
1		Priming / drain plug assy	2
2		Kit - bolt & nut	1
3		Casing assy - yellow 2" BSPT 9, 10 & 13 hp & HQ models	1
3		Casing - yellow 1.5" BSPT All other models not specified	1
4		Flap valve assembly	1
4		Flap valve assy - viton	1
5		Diffuser coverplate 9, 10 & 13 hp models	1
5		Diffuser coverplate All other models not specified	1
6		Neckring 9, 10 & 13 hp models	1
6		Neckring All other models not specified	1
7		Screw - Impeller (pk 4)	1
8		Impeller assy 1 stage 35mm 10hp model only	1
8		Impeller assy 1 stage 3/4" 7hp model only	1
8		Impeller assy 1 stage 1" 9 & 13hp models only	1
8		Impeller assy 1 stage 5/8" All other models not specified	1
8a		Impeller front 1 stage Not applicable to 10 or 13hp models	1
8b		Impeller back 1 stage 3/4" 7hp models only	1
8b		Impeller back 1 stage 5/8" Up to 7hp including B/Shaft	1
9		Neckring balance	1
10		Kit - bolt washer oring (pk4)	1
11		Seal Mechanical 35mm Type 2100 10hp model only	1
11		Seal - mechanical 3/4" 7hp model only	1
11		Seal mechanical 33mm Type 2100 9 & 13hp models only	1
11		Seal - mechanical 5/8" type 6 All other models not specified	1
12		Oring - casing	1
13		Casing - rear 35mm 10hp model only	1
13		Casing - rear yellow 3/4" 7hp models only	1
13		Casing - rear yellow 9 & 13hp models only	1
13		Casing - rear yellow 5/8" All other models not specified	1
14		Gasket - discharge 3 way	1
14		Gasket - discharge 4 way	1
15		4 way discharge - yellow BSPT	1
15		4 way discharge (no handle) - yellow BSPT	1
15		Outlet 3 way 1.5" BSPT 9hp & above	1
15		Outlet 3 way 2" BSPT 9hp & above	1
16		Screw outlet (pk 3) 3 way discharge	1
17	A	Cap assy blank 1.5" BSP	2
18	A	Gasket 1 1/2" cap	2
19		Cap assy blank 1" BSP	2
20		Gasket - 1" cap	2
21		Gasket - 2" cap	1
22		Cap - 2" BSP	1
23		Bracket - front case yellow 9 & 13hp models only	1
24		Kit - bearing bareshaft Bareshaft only	1
25		Shaft - m/c b/shaft sp Bareshaft only	1
26		Housing - bearing Bareshaft only	1
27		Screw handle (3 pack) 4 way discharge	1
28		Mounting foot assy 9 & 13hp models only	2
		Viton seal kit 5 series All other models - not illust.	1
		Viton seal kit 5/8" 1 stage 3 way H3 & HQ only - not illust.	1
		Viton seal kit 3/4" 1 st 4 way outlet 5170Y/YE only - not illust.	1
		Viton seal kit 35mm 1 st 3 way 10hp model only - not illust.	1
		Viton seal kit 33mm 1st 3 way 9 & 13hp models only - not illust.	1
		Seal kit - 5.5 / 6.5hp 1 stage	1
		Seal kit - 9/13hp 5 series 1 st	1
		Seal kit 10hp 1 stage	1
		Seal kit 7hp 1 stage	1
		Disc - location 9 & 13hp models only - not illust.	1

DAVEY WATER PRODUCTS GUARANTEE FOR AUSTRALIA & NEW ZEALAND
 This Davey product is guaranteed to be free of material or manufacturing defects at the time of original purchase. Should any part fail as a result of such defects within one year of original purchase, the product will be repaired free of charge.
 Guarantee on engines fitted to Davey pumps is the responsibility of the engine manufacturer or his representative and is subject to the particular manufacturer's stated guarantee terms and conditions as per the operating instructions included with the pump.

TERMS AND CONDITIONS

1. This guarantee applies to all states and territories of Australia and New Zealand only and is subject to the provisions of the Trade Practices Act (Aust.), the Goods and Consumer Protection Legislation of the various Australian states and the Consumers Guarantee Act 1993 (NZ) as applicable.
2. The guarantee period commences on the date of original purchase of the equipment. Evidence of this date of original purchase must be provided when claiming repairs under guarantee. It is recommended you retain all receipts in a safe place.
3. This guarantee covers parts and workshop labour only. Goods should be forwarded, with proof of date of original purchase, to an Authorised Davey Service Centre freight paid.
4. This guarantee is subject to due compliance by the original purchaser with all directions and conditions set out in the Installation and Operating Instructions. Failure to comply with these instructions, damage or breakdown caused by fair wear and tear, negligence, misuse, incorrect installation, chemical or additives in the water, inadequate protection against freezing, rain or other adverse weather conditions, corrosive or abrasive water, lightning or high voltage spikes or through unauthorised persons attempting repairs are not covered under guarantee. The product must only be connected to the voltage shown on the nameplate.
5. Without limiting the original purchaser's entitlements under the Trade Practices Act (Aust.), the Goods & Consumer Protection Legislation of the various Australian states, or the Consumers Guarantee Act 1993 (NZ), Davey shall not be liable for any loss of profits or any consequential, indirect or special loss, damage or injury of any kind whatsoever arising directly or indirectly from the product or any defect.
6. Where the Trade Practices Act (Aust.), the Goods and Consumer Protection Legislation of the various Australian states and the Consumers Guarantee Act 1993 (NZ) does not apply, Davey shall not be liable for any loss of profits or any consequential, indirect or special loss, damage or injury of any kind whatsoever suffered by the purchaser arising directly or indirectly from the product or any defect and the purchaser shall indemnify Davey against any claim by any other person whatsoever in respect of any such loss, damage or injury.
7. Nothing in this guarantee is intended to have the effect of contracting out of the provisions of the Trade Practices Act (Aust.), the Goods and Consumer Protection Legislation of the various Australian states and Consumers Guarantee Act 1993 (NZ) except to the extent permitted by the various Acts and this guarantee is to be modified to the extent necessary to give effect to that intention.
8. Davey may be collecting personal information from you in order to provide you with a service. Davey Water Products Pty Ltd promises only to use this information in accordance with the Provisions of the Privacy Act 1988 (Cth) and the Privacy Policy of Davey Water Products Pty Ltd which is available at davey.com.au.

© Davey and Firefighter are registered trademarks of Davey Water Products Pty Ltd.

© Davey Water Products Pty Ltd 2004

Davey Water Products Pty Ltd

Member of the GUD Group

ABN 18 066 327 517

Head Office and Manufacturing

6 Lakeview Drive,
 Scoresby, Australia 3179

Ph: +61 3 9730 9222

Fax: +61 3 9753 4100

Webiste: davey.com.au

Customer Service Centre

Ph: 1300 367 866

Fax: 1300 369 119

E-mail: sales@davey.com.au

Interstate Offices

Sydney • Brisbane • Adelaide
 Perth • Townsville

International

6 Lakeview Drive,
 Scoresby, Australia 3179

Ph: +61 3 9730 9222

Fax: +61 3 9753 4248

AH: +61 3 9730 9121

E-mail: export@davey.com.au

Germany

Kantstrasse 53,
 04275 Leipzig

Ph: +49 341 301 0412

Fax: +49 341 301 0413

E-mail: akrenz@daveyurope.com

New Zealand

7 Rockridge Avenue,
 Penrose, Auckland 1330

Ph: +64 9 570 9135

Fax: +64 9 527 7654

Webiste: daveynz.co.nz

E-mail: sales@daveynz.co.nz

U.S.A. - Davey Pumps Inc.

1005 N. Commons Drive
 Aurora, Illinois 60504

Ph: +1 630 898 6976

Fax: +1 630 851 7744

Webiste: daveyusa.com

E-mail: sales@daveyusa.com

P/N 49367-3 supersedes P/N 49367-2

PORTABLE SELF PRIMING PUMPS

INSTALLATION AND OPERATING INSTRUCTIONS

DEPEND ON
DAVEY
 WATER PRODUCTS



These Instructions and the accompanying engine manufacturer's instructions must be delivered with the pump to the operator.



NOTE:

- Your Davey pump is fitted with a four stroke engine WHICH REQUIRES OIL IN THE SUMP.
- Petrol engines require UNLEADED petrol in the fuel tank.
- Read ALL instructions to avoid equipment failure which may not be covered by guarantee.
- Fill sump with oil and pump with water before starting. YANMAR diesel engines do not have low oil protection. Check oil levels and maintain oil quality regularly.

Engine: Fill sump with oil to correct level before starting the four stroke engine.
 Operation at high altitudes, high temperatures and/or humidity will reduce engine performance.



IMPORTANT NOTICE:

The Honda and Briggs & Stratton engines fitted to Davey Firefighters® have an automatic oil level cut-out which will stop the engine and/or prevent starting when oil level is low and/or when engine is tilted.

IN EMERGENCY CIRCUMSTANCES ONLY, OIL LEVEL CUT-OUT MAY BE DISABLED AS FOLLOWS:

FOR HONDA: Disconnect yellow lead to starting switch at 'bullet' junction.
FOR BRIGGS & STRATTON: Remove lead from 'oil guard' sensor. In Vanguard models this should be done at the sensor light. In INTEK models this should be done at the sensor plug, which is located in the crankcase cover.

NOTE: WARRANTY FROM THE ENGINE MANUFACTURERS MAY BE JEOPARDISED BY SUCH ACTIONS.

READ ALL INSTRUCTIONS BEFORE OPERATING PUMP

WARNING: Engine manufacturer's instructions must be followed to ensure safe operation of this product and to avoid possible engine damage or reduced engine life.

! In accordance with AS 3350.2.41 we are obliged to inform you that this pump is not to be used by children or infirm persons and must not be used as a toy by children.

PUMP LOCATION:

For most efficient operation, site the pump as close to the water as practical. It is essential for the correct function of the engine that it be located on a horizontal surface. If allowed to run at an inclination, the oil lubrication system of the engine may not operate correctly. Subsequent engine failure would not be covered by the manufacturer's guarantee. The pump should be positioned in a well drained location to avoid possible property damage by leaking hose fittings or pump seals, spilled engine fuel etc. If you intend to operate your pump on a hard surface, Davey suggest a suitable resilient mounting to be fitted to your pump and engine.

SUCTION PIPE:

A reinforced or non-collapsible hose should be used for the pump suction. The minimum suction pipe size should be 38mm (1 1/2") I.D. for up to 6.5hp Firefighter® models, 50mm (2") I.D. for G5006 and 9hp & 13hp Firefighter® models and 80mm (3") I.D. for G8016 Firefighter® models. A strainer should always be fitted to the bottom of the suction pipe. The strainer should be kept out of sand, mud etc., to avoid particles being drawn into the pump and causing damage by abrasion. Always locate the pump so that the rise of suction pipe from water to pump is even with no humps or hollows where air may be trapped. All pipe connections must be air tight for best priming and operation - check that washers in nuts and tails are in good order.

DELIVERY PIPE:

Care should be taken on correct selection of pipe pressure rating as single stage Firefighter® units are capable of delivering pressures up to 650kPa (93psi). Two stage Firefighter® Plus units are capable of pressures up to 1135kPa (165psi).

PUMP PRIMING:

To prime the pump initially, it is necessary to fill the pump body with water before starting the engine. The priming plug and drain plug both have "bayonet" style fitting, with a safety release mechanism. When correctly installed the plug handles will be as shown in illustration one below. To remove the plug, first twist it counter-clockwise approximately 60 degrees till any pressure is released (see illustration two). At this point the plug will partly disengage. Once any residual pressure has been released the plug can be fully removed by continuing to turn it to the 90 degree position (see illustration three).

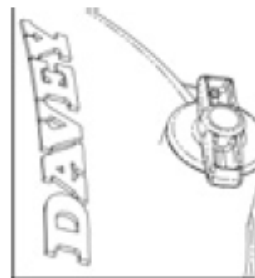

Illustration 1



Illustration 2



Illustration 3

Keep the plug and it's surround free from sand and grit. Occasionally apply a suitable silicon based rubber grease (petroleum based greases are not acceptable) to the oring. The pump drain plug is identical in operation. Both plugs are available with a 1/4" BSP tapping to facilitate the fitting of pressure gauges or automatic drain valves etc.

PUMP PRIMING continued...

Choke and start engine, open discharge then allow the pump to run until it is drawing water. The pump will establish prime better at higher engine speeds. Allow up to 3 minutes for long or deep suction.

If the pump fails to prime, then it may be due to the pump flap valve not seating properly, an air leak in the suction pipe or fittings, a blocked suction pipe, or the bottom end of the pipe embedded in mud.



NOTE: When transporting your Davey Portable Self Priming Pump, water from the casing may leak back past the priming flap. Before attempting to self prime the pump you may need to check that the pump casing is full of water.

PUMP OPERATION:

High performance can be obtained from these pumps if the engine speed is increased, however, we do not recommend the pumps be operated over 3600rpm for extended periods, as this may overload the engine and reduce its working life. Operating the engine at full throttle for extended periods will shorten engine life and may result in premature failure. For operations such as irrigation or dam and tank filling, the throttle should be closed to around 3/4 maximum. This should correspond to around 3000rpm maximum.

AVOIDING PUMP DAMAGE:

Pumping water containing sand, dirt or other abrasive materials will result in accelerated pump wear and seal failure. Damage of this kind is not covered by guarantee.

Pumping water containing chemicals or high concentrations of salt may damage pump components. If the pump is used for this kind of service, life will be extended by always washing thoroughly with clean water after use. However, Davey cannot accept responsibility for damage caused by chemicals, salt or corrosive fluids.

Pumping hydrocarbon based liquids, even in diluted form, is likely to cause damage to internal pump components and such failure is not covered by guarantee.

SPECIAL MODELS - Viton Seal Equipped

These special models, identified by a black handle (when factory fitted) or a sticker (when fitted in the field), have been supplied with Viton® seals and elastomers. This is to provide the pump with superior resistance to common agricultural chemicals. These pumps should still be flushed out with clean water after use.

STORAGE OF UNIT:

The pump unit should be drained of water and normal engine storage procedure should be followed. (Run unit until fuel is exhausted, drain and fill sump with fresh oil.) The unit should be stored in a dry place. Before starting pump after storage it should be checked to make sure that it is free to rotate by pulling Engine Starter with ignition off.

REMOVAL OF IMPELLER:

Pump impeller is screwed clockwise onto the engine shaft. The impeller assembly is fixed together by a setscrew and can be disassembled in two halves by removing the setscrew or the entire impeller assembly can be removed.

To remove the entire impeller assembly, unscrew locking setscrew or impeller/s anti-clockwise using a socket in eye of impeller. If difficult to remove, lock engine crankshaft at recoil starter end.



WARNING: In the event of fire damage to the Viton® elastomers ("rubber"), consult your Davey dealer regarding safe handling of burnt Viton® components. Burnt Viton® emits a dangerous acid, which can cause serious health effects.



NOTE: The pump body should always be full of water when operating, and must not be allowed to run dry for extended periods. Check that there is flow through pump at all times when running as insufficient flow can cause damage not covered by guarantee.



WARNING: Pump may contain hot liquid under pressure.

Croplands Technical Service
1300 650 724

Croplands Australia:
Freecall 1800 999 162
Freefax 1800 623 778
sales@croplands.com.au
www.croplands.com.au