

**CROPLANDS**

# OPERATORS MANUAL **RETRASPRAY**

**ELECTRIC REEL MODELS:**

**RSRL3-100RC REEL**

**US20F/25/100R3, US30F/30/100R3, US500/30/100R3, US500/40/100RT3, US60F/40/100RT3**

**[WWW.CROPLANDS.COM.AU](http://WWW.CROPLANDS.COM.AU)**

**STOP**

**BEFORE COMMENCING**  
operation, **ENSURE** you read  
& understand this manual, its  
contents, and any additional  
information supplied.



**GP-OMRET-B FSC**



**CROPLANDS IS CONTRIBUTING TO A SUSTAINABLE FUTURE**

# INTRODUCTION

## GENERAL MANAGER'S WELCOME



**Sean Mulvaney**  
**General Manager**

Dear Customer

Congratulations on the purchase of your new sprayer and thank you for supporting another true blue Australasian manufacturer. For over 50 years Croplands have been delivering spraying solutions and ongoing support for a variety of applications whilst investing in long term partnerships with our suppliers, distributors, end users and local communities. These partnerships are absolutely key in our commitment to support our products into the future.

At Croplands, we are committed to sourcing the very best technology from around the globe and adapting these products to our specific requirements. When these products don't yet exist, we innovate through continuous investment in our own research and development.

Croplands is a wholly owned subsidiary of Nufarm Ltd, the largest supplier of crop protection products in Australasia. This brings a unique understanding and collaborative approach to new market developments, challenges and opportunities.

Please take the time to thoroughly read this manual before you operate your sprayer. This will provide direction to ensure safe usage and help optimise the performance of your investment. Your feedback is welcome and valued.

We trust you will be happy with your sprayer and the level of support - our goal is to be your preferred spraying solutions partner from this point onwards.

Yours Sincerely

**Sean Mulvaney**  
**General Manager**

Croplands has taken steps to ensure this operator's manual is as current and as accurate as possible. Due to the ever-changing markets of cropping and farming, Croplands is constantly striving to be at the forefront of innovation and technology. While the information in this manual is considered accurate at the time of writing, Croplands reserves the right to change this information without notice. Croplands will not accept liability for any inaccuracy in this publication, or changes forthwith.



# CONTENTS

## SECTION 1 IMPORTANT INFORMATION

Foreword	4
About this manual	4
Terminology	4
Warranty Policy	5

## SECTION 2 SAFETY

Safety signs and decals	6
-------------------------	---

## SECTION 3 PRODUCT IDENTIFICATION, & SPECIFICATION

Retraspray Electric Reels	7
Key features	7
Croplands Retraspray Unit	8
Specifications	8
US20F, 30F & 60F models	12
US500 models	14

## SECTION 4A SET-UP & OPERATION OF RETRASPRAY REEL

Retraspray Reel	16
Unpacking your unit	16
Hard wiring to vehicle battery	16
Retraspray key components	17
Tuning transmitter to receiver	18
Using the transmitter to retract the hose	19
Using the manual button to retract the hose	19
Tips & hints	19
Caution - radio interference	20
Maintenance	20
Troubleshooting	20

## SECTION 4B PRE-OPERATION - TRAYMOUNT SPRAYER

Electric reels - Retraspray	21
Unloading	21
Fitment	21
Hook-up	21
Description of the plumbing	21
Spray gun	23
Spray guns & accessories	24
Filling, filters & draining	24
Pre-operation check-list	25
Initial start-up procedure, motorised sprayer	25
Shut down	26

## SECTION 5 OPERATION

Safety first	29
Daily start-up procedure	29
Adding chemical to the spray tank	29
Operating the spray gun	30
Hand gun spraying method	31
Operating pointers	31
Emergency Action Plan	31
Clean & flush the sprayer	32
Using tank & equipment cleaners	32

## SECTION 6 SPRAYING INFORMATION & CALIBRATION

When to spray	33
Useful formula	33
Calibration - general	33
Spot sprayer calibration	33
Spray quality	34

## SECTION 7 MAINTENANCE & TROUBLESHOOTING

Daily maintenance	35
20 hours maintenance	35
Annual maintenance	35
Troubleshooting pump problems	36

## SECTION 8 ASSEMBLY DRAWINGS **37**

200F / 300F BASE ASSEMBLY	38
US20F/25/100R3	39
US30F/30/100R3	40
600F BASE ASSEMBLY	41
US60F/40/100RT3	42
US500/40/100RT3	43
WIRING SCHEMATIC	44

## SECTION 9 INDEX **45**

# SECTION 1

## IMPORTANT INFORMATION

### FOREWORD

Croplands Equipment is a subsidiary of Nufarm Australia Ltd and operates as Croplands Equipment Pty Ltd in Australia and Croplands Equipment Ltd in New Zealand. Croplands are a leading manufacturer and supplier of spraying equipment.

This operator's manual covers the Croplands' range of Retraspray Units.

Manufactured to a high standard for use in Agriculture and Horticulture, every effort has been made to include all information needed for the correct use of your Retraspray Unit.

### ABOUT THIS MANUAL

This manual provides assembly, setting up, operating and maintenance instructions for the Retraspray reel or Retraspray Unit. All models of the Retraspray units are listed in Section 3, Product Identification and Specification.

Some model types also have different options available. Some features explained in this manual may not be applicable to your model.

Please pass on this manual with the sprayer or boom at the time of resale for use by the new owner.

This Retraspray manual (issue B), was published in September 2022 and completely replaces issue A.

November 2023 = FSC Update.

Check online as there may be more recent revisions of this manual.



As the owner of a Croplands product, please read this manual thoroughly to fully familiarise yourself with all aspects of the safe and correct operation of your Retraspray units. Maintenance information and useful tips have been included. We trust you will use these tips to get the best from your Retraspray Unit.

### TERMINOLOGY

These terms/symbols used throughout this manual:

<b>NOTE</b>	This Note sign is in place to convey useful information and will help you to identify the best possible way to operate the machine.
<b>CAUTION</b>	This Caution sign shows the potential for incident. An incident may include damage to the machine itself, or possible injury to the operator.
<b>WARNING</b>	This Warning sign shows the potential for risk or injury and highlights the need for steps to be taken to protect ones safety.
<b>DANGER</b>	This Danger sign will be used in areas where the highest risk is present. Always read the information on these signs and ensure you are taking steps to prevent risk or injury.

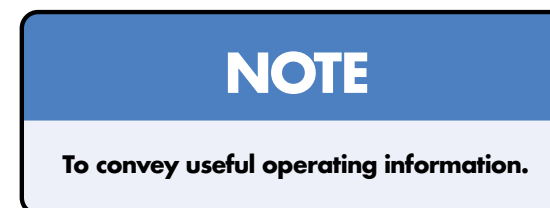

### INTENDED USE

Croplands sprayers are designed to be used for multipurpose spraying of herbicides, pesticides and fertilisers. The sprayer must not be used for any other purpose.

# SECTION 1

## IMPORTANT INFORMATION

### WARRANTY POLICY

Each sprayer module will be delivered with a Specifications, Safety, Warranty & Delivery Booklet which includes:

- the sprayer's specification sheet including the sprayer's unique serial number,
- a safety induction checklist,
- a delivery checklist and customer induction,
- the Croplands Warranty policy and warranty registration form.

**We ask that our customers complete these forms in the presence of a Dealer and/or Croplands representative as a part of the sprayer's delivery process.**

Always contact your Croplands Dealer first and foremost for warranty matters.

### NOTE

For full conditions of warranty and warranty policy, please see the Specification, Safety, Warranty & Delivery booklet provided with this sprayer.

# CROPLANDS

## WARRANTY & PRE-DELIVERY UTILITY SPRAYERS

[WWW.CROPLANDS.COM.AU](http://WWW.CROPLANDS.COM.AU)



**STOP**  
BEFORE COMMENCING operation, **ENSURE** you read & understand this manual, its contents, and any additional information supplied.

GP-WARO-A

 CROPLANDS IS CONTRIBUTING TO A SUSTAINABLE FUTURE

# SECTION 2

## SAFETY

The supplied (as a separate document along with this sprayer) Croplands SAFETY manual must be read and understood before operating your Retraspray units.



### SAFETY SIGNS AND DECALS

All signs and decals for sprayer safety and operation must be maintained in good order and replaced if damaged or missing. Most Croplands labels have a part number printed on the decal to aid identification and replacement.

Some examples are shown below.

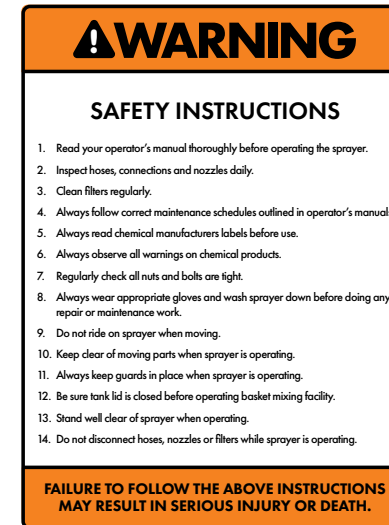

Part No: XD -123



Part No: XD -125V



Part No: XD -126V



Part No: XD -116V



Part No: XD -127V



# SECTION 3

## PRODUCT IDENTIFICATION & SPECIFICATION

### RETRASPRAY ELECTRIC REELS

The Retraspray, electric retractable reels are manufactured for Croplands by Quik Corp. They are available as stand alone units or as a part of the Croplands electric reel traymount units.

The standard (right hand) unit is Croplands part number RSRL3-100RC.

Twin electric reel TrayPak units also use a "left hand" unit, part code RSRL3L-100RC.



All reel units are fitted with a serial number / identification plate. Whenever possible, use the serial number of the reel when requesting service or parts information (for a stand alone reel). Refer next page for Traymount serial numbers.

### KEY FEATURES



1. 12V 1/5HP low-rev motor directly coupled to the reel. Connect to 12V DC power source using heavy-duty power cable supplied.
2. Push-button hose retraction and remote-control rewind standard. The high power remote control transmitter operates over a range of up to 300 metres. Frequency = 915 Mhz.

3. 100m of Quik Spray's own Supa-Slip® high grade nylon hose .... which is a polyamide bio plastic derived from vegetable oil which offers advanced performance and strength.

Compared to lower grades of Nylon commonly used, the Supa-Slip® hose has higher operating pressures and tensile strength. It is also more resistant to cold and hot extremes. The additives in the hose mean it is less likely to kink or stretch giving it a longer life cycle

Includes low friction roller guides for hose run-out & retraction.



# SECTION 3

## PRODUCT IDENTIFICATION & SPECIFICATION

### CROPLANDS RETRASPRAY UNIT

Whenever possible, use the serial number of the Retraspray Unit when requesting service or parts information.

Where a serial plate is not provided or is no longer on the unit, use the part number from the bar code affixed to this manual or the Warranty & Pre-delivery booklet.



### SPECIFICATIONS

#### Tanks

The Croplands Traymount range of tanks are constructed from UV stabilised, medium density polythene for low distortion qualities and impact resistance. A screw down main lid is installed on all models and comes standard with a basket strainer. A deep sump provides excellent suction and allows the tank to completely drain.

Each main tank has volume level markings at the main lid end of the tank. Note the accuracy is dependent on ground level.

The 200, 300 & 600 Lt models incorporate a (red) 6 litre fresh water tank for operator safety, hand washing, filter cleaning etc.





# SECTION 3

## PRODUCT IDENTIFICATION & SPECIFICATION



### Honda Power

Croplands motorised Retraspray models use genuine Honda petrol powered motors - famous for delivering reliable, easy starting, fuel efficient performance, day in and day out.

Each motor is affixed with an identification label showing the manufacturer, model, serial number and manufacturing codes. For further information on parts etc, refer to the parts section on the Croplands website.

### Pumps

Coupled to each Honda motor is an industry leading AR brand, diaphragm pump of a capacity to suit each



AR252-CRGI

# SECTION 3

## PRODUCT IDENTIFICATION & SPECIFICATION



AR30-CRGI

Retraspray model.

Each pump is fitted with a suitable AR manual control valve and regulator.

The pump identification label shows the name of the manufacturer, model of the pump, serial number, maximum working pressure and other requirements.

For further information on parts for your pump, refer to the parts section on the Croplands website. Use the pump model as the reference.



AR Gi40



AR40-CRGI

# SECTION 3

## PRODUCT IDENTIFICATION & SPECIFICATION

### Spray Guns

Croplands Retraspray Unit range is available with either single or twin 30 meter hose reel and Turbo Gun 400.



### Manuals

Separate manuals for the motor/pumps are supplied along with the unit.



# SECTION 3

## PRODUCT IDENTIFICATION & SPECIFICATION



US30F/30/100R3



US60F/40/100RT3



# SECTION 3

## PRODUCT IDENTIFICATION & SPECIFICATION

### ELECTRIC REELS

# TrayPak

Croplands motorised sprayers are powered by genuine Honda motors with larger diaphragm pumps to give better spray pressure for those larger jobs.

POWERED by  
**HONDA**™

#### KEY FEATURES

1. Heavy-duty hot-dip galvanised frame
2. UV-stabilised main tank with level markings
3. Large filling lid with basket strainer
4. Separate 6 Litre hand wash tank & tap
5. Large sump for total emptying and easy draining and clean out
6. Genuine Honda motor to power the reliable AR diaphragm pump
7. Retraspray electric reel with 100m high quality hose and Turbo400 gun

UNIT	WIDTH	LENGTH	HEIGHT	WEIGHT
<b>US20F/25/100R3</b>	1360mm	990mm	805mm	132kg
<b>US30F/30/100R3</b>	1360mm	990mm	805mm	146kg
<b>US60F/30/100R3</b>	1255mm	1575mm	990mm	197kg
<b>US60F/40/100RT3</b>	1300mm	1575mm	990mm	237kg

Disclaimer: dimensional and weight information supplied is for base model only with no options. This information is subject to change without notice.

<b>US20F/25/100R3</b>	200L traymount sprayer with galvanised frame, Honda-powered 25 L/min pump, 12V auto-retractable. RetraSpray reel with 100m of non-kink spray hose and Turbo400 gun. 6L handwash tank
<b>US30F/30/100R3</b>	300L traymount sprayer with galvanised frame, Honda-powered 35 L/min pump, 12V auto-retractable. RetraSpray reel with 100m of non-kink spray hose and Turbo400 gun. 6L handwash tank
<b>US60F/30/100R3</b>	600L traymount sprayer with galvanised frame, Honda-powered 35 L/min pump, 12V auto-retractable. RetraSpray reel with 100m of non-kink spray hose and Turbo400 gun. 6L handwash tank
<b>US60F/40/100RT3</b>	600L traymount sprayer with galvanised frame, Honda-powered 46.3 L/min pump, twin 12V auto-retractable. RetraSpray reels with 100m of non-kink spray hose and Turbo400 guns. 6L handwash tank

# SECTION 3

## PRODUCT IDENTIFICATION & SPECIFICATION

**POWERED by**  
**HONDA™**



US500/30/100R3

UNIT	WIDTH	LENGTH	HEIGHT	WEIGHT
<b>US500/30/100R3</b>	1200mm	1700mm	1200mm	218kg
<b>US500/40/100RT3</b>	1200mm	1700mm	1200mm	248kg

Disclaimer: dimensional and weight information supplied is for base model only with no options. This information is subject to change without notice.

<b>US500/30/100R3</b>	500L traymount sprayer with galvanised frame, Honda-powered 35 L/min pump, 12V auto-retractable. RetraSpray reel with 100m of non-kink spray hose and Turbo400 gun
<b>US500/40/100RT3</b>	500L traymount sprayer with galvanised frame, Honda-powered 46.3 L/min pump, twin 12V auto-retractable. RetraSpray reels with 100m of non-kink spray hose and Turbo400 guns
<b>US500/40/TWIN</b>	TrayPak 500L, AR40 pump, twin reel both with 30m hose and Turbo400 gun, galvanised skid frame



# **SECTION 4A & 4B**

## **SET-UP & PRE-OPERATION**

### **4A - RETRASPRAY REEL**

<b>UNPACKING YOUR UNIT</b>	<b>16</b>
<b>HARD WIRING TO VEHICLE BATTERY</b>	<b>16</b>
<b>RETRASPRAY KEY COMPONENTS</b>	<b>17</b>
<b>TUNING TRANSMITTER TO RECEIVER</b>	<b>18</b>
<b>USING THE TRANSMITTER TO RETRACT HOSE</b>	<b>19</b>
<b>USING THE MANUAL BUTTON TO RETRACT HOSE</b>	<b>19</b>
<b>TIPS &amp; HINTS</b>	<b>19</b>
<b>CAUTION - RADIO INTERFERENCE</b>	<b>20</b>
<b>MAINTENANCE</b>	<b>20</b>
<b>TROUBLESHOOTING</b>	<b>20</b>

### **4B - TRAYMOUNT SPRAYER**

<b>ELECTRIC REELS - RETRASPRAY</b>	<b>21</b>
<b>UNLOADING</b>	<b>21</b>
<b>FITMENT</b>	<b>21</b>
<b>HOOK-UP</b>	<b>21</b>
<b>DESCRIPTION OF THE PLUMBING</b>	<b>21</b>
<b>SPRAY GUN</b>	<b>23</b>
<b>SPRAY GUNS AND ACCESSORIES</b>	<b>24</b>
<b>FILLING, FILTERS &amp; DRAINING</b>	<b>24</b>
<b>PRE-OPERATION CHECK-LIST</b>	<b>25</b>
<b>INITIAL START-UP PROCEDURE, MOTORISED SPRAYER</b>	<b>25</b>
<b>SHUT DOWN</b>	<b>27</b>

# SECTION 4A

## SET-UP & OPERATION OF RETRASPRAY REEL

### RETRASPRAY REEL

#### UNPACKING YOUR UNIT

When unpacking your new Quik Spray unit, please check it thoroughly for any transport damage that may have occurred during transit. Check that all parts and accessories that were ordered, have been included.

Mount the machine securely by bolting through all mounting lugs located at the on the base of the frame. Ensure a minimum of 50mm clearance from all sides to prevent damage.

Connect the spray hand piece of your choice to the hose and adjust the nylon hose stopper approximately 1 meter from the end of the hand piece.

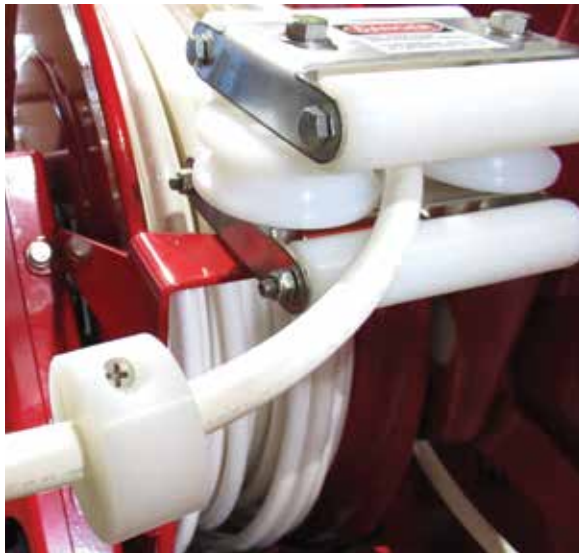

#### HARD WIRING TO VEHICLE BATTERY

Leads must be at least 3/8" starter cable or larger and a "fusible link" (80 amp) must be connected in the main power lead at the battery end, to prevent fire in the case of an accidental short circuit.

2 x Anderson plugs have been fitted to the unit for ease of connection. For best results use a fully charged heavy duty battery, 70AH or larger.



Finger tighten and a tiny bit more, is all that the aerials require to be attached properly.

Over-tightening the aerials can cause the coax cable to break in the solder cap of the aerial base severing the connection to the aerial. This can result in a radio range of only 20-40 meters rendering the aerial/s incapable of receiving a signal.



# SECTION 4A

## SET-UP & OPERATION OF RETRASPRAY REEL

### RETRASPRAY KEY COMPONENTS

- A. Main switch.
  - Off is the default central position
  - Push and hold up (spring loaded) for manual rewind. Make sure fingers etc are clear of the reel.
  - Push down to activate the remote control function (refer next page).
- B. 2 x Anderson plug 50 amp power in/out. Power can plug to either side.
- C. Resettable circuit breaker 30amp
- D. 12V motor & drive
- E. Aerial
- F. 915MHz radio receiver ... refer next page for internal details including dip switches.



# SECTION 4A

## SET-UP & OPERATION OF RETRASPRAY REEL

### TUNING TRANSMITTER TO RECEIVER

Radio receiver dip-switch code must match the radio transmitter dip-switch code.

Each unit is delivered pre-tuned from the factory. If at some point a new radio transmitter or receiver board is required, the dip-switch codes will need to be realigned.

Note; if two or more 915 MHz systems are in use in the near vicinity make sure that the dip-switch codes from one system to the other are different. If they are too close in dip-switch combination radio interference or cancellation can occur from one unit to another.

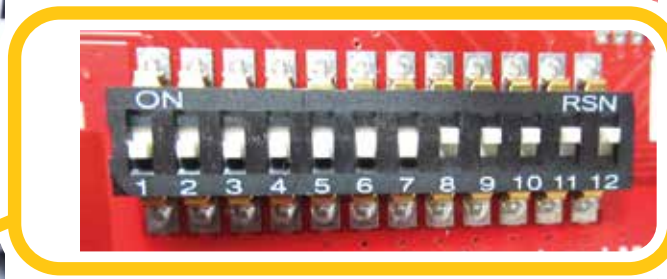

Note the dip-switch positions are identical for both transmitter and receiver are the same. The transmitter switches are accessed via the battery compartment.



# SECTION 4A

## SET-UP & OPERATION OF RETRASPRAY REEL

### USING THE TRANSMITTER TO RETRACT HOSE

Ensure all set-up instructions are complete.

When you are ready to operate the reel, turn the radio switch ON and carry the transmitter with the operator. The reel will free-wheel out to the desired distance.



### CAUTION

**Do not pull hose out too fast, as the reel may "run on", causing the hose to become entangled. When you are ready to retract the hose, press and hold the transmitter button to retract the hose back to the unit.**



### CAUTION

**Always ensure the hose is in front of the operator. To operate the transmitter for retraction, the operator must be at least 2-3 metres away from the unit.**



### USING THE MANUAL BUTTON TO RETRACT HOSE

For manual retraction of the reel, use the manual switch.

This unit has been designed to operate in a continuous start/stop mode without damage to the unit. Keep tension on the hose when rewinding to enable the hose to slip into the low spot on the reel drum.



### CAUTION

**Be ready to release the radio transmitter button when approaching the reel, as injury may result.**



### CAUTION

**Use the manual button on the radio receiver box to retract any slack hose within 2 metres of the unit.**



### TIPS & HINTS

Turn the radio switch off and disconnect from the battery when not in use.

- If the hose becomes entangled or caught, release the retraction button immediately or damage to the motor could result.
- Keep the unit under cover when not in use.
- A low power or voltage battery will cause weak or intermittent operation of the units motor. This can cause damage to the radio relay.
- Always insure that the 9 Volt battery in the transmitter is replaced every 3 months and that the 12 Volt power supply is charged on a regular basis and putting out optimal Voltage.



# SECTION 4A

## SET-UP & OPERATION OF RETRASPRAY REEL

### CAUTION - RADIO INTERFERENCE

The radio transmitters working range can be affected by the many factors that typically affect all 915 MHz and 433 MHz radio Transmissions. These include operating in the vicinity of high tension power lines, buildings and other obstructions. Interference can also come from other radio transmitters, and certain atmospheric conditions.

A range of 100 meters or more can be achieved under ideal conditions.

### MAINTENANCE

#### Daily

- Check the battery condition.
- Make sure all safety guards and decals are in place.
- Inspect all nuts and bolts for missing or loose items.
- Check all hoses and hose fittings for damage or leaks.
- Ensure the aerial is a little more than finger tight to the aerial base **DO NOT OVER TIGHTEN.**

#### 20 hours

Grease the reel swivel if needed. Do not over grease as damage will occur to the swivel.

#### Yearly

Replace the 9 volt transmitter battery.

Grease all bearings if needed and do not over grease. The motor brushes must be checked by an auto electrician.

### TROUBLESHOOTING

PROBLEM	PROBABLE CAUSE	REMEDY
<b>Reel does not retract and manual button does not work</b>	ON\OFF switch not ON or faulty	Switch ON or replace switch
	Discharged 12 volt battery	Recharge battery
	Loose connection on 12 volt battery	Fix loose connection
	Circuit breaker tripped	Reset circuit breaker
<b>Reel does not retract and manual button works</b>	Discharged 9 volt transmitter battery	Replace 9 volt battery
	Faulty radio receiver board, pre-regulator board or transmitter	Return radio receiver to Quik Spray with transmitter for testing and repair
	Dip-switch (915 MHz) or digital code (433 MHz) not synchronised	Rematch dip-switch codes (915 MHz) or re-tune (433 MHz)
<b>Reel does not retract and manual button does not work</b>	Discharged 9 volt battery transmitter battery	Replace 9 volt battery
	Aerial broken or loose on base	Tighten or replace
	Coax cable broken inside the aerial base	Repair or replace coax cable and aerial base
	Discharged 12 volt battery	Recharge or replace
	Faulty receiver board or transmitter	Return radio receiver to factory with transmitter for testing and repair. (CALL FIRST FOR PROCEDURE)
	Aerial braid not connected to negative supply	Reconnect



# SECTION 4B

## PRE-OPERATION - TRAYMOUNT SPRAYER

### ELECTRIC REELS - RETRASPRAY

See Section 4A re set-up and operation of the Retraspray electric hose reel.

### UNLOADING

Take care when loading / unloading these sprayers. These sprayers are well past the capacity for one or two people to manually handle. Most models have either forklift or sling pickup points. Be careful of the balance.

All loading / unloading should be done with tanks empty. See Section 5 of the Safety manual.

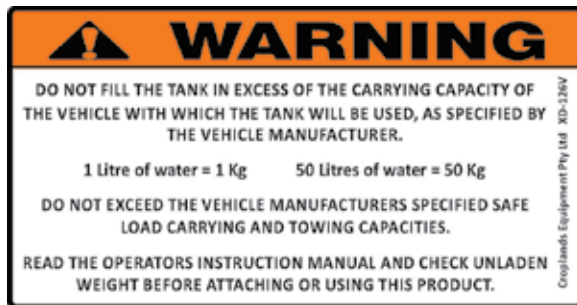

### FITMENT

Make sure the unit is securely fastened. In many cases this will involve bolting the unit to a vehicle. Remember to factor in the weight of a full tank when determining the mounting, and always consult the vehicles manual for load ratings and suitable mounting points.

### HOOK-UP

Connect & route a drain hose to a convenient and safe place for draining the tank.

### DESCRIPTION OF THE PLUMBING

There are 3 configurations of the plumbing for the motorised pump sprayers – dependent on the choice of pump.

- The AR252 pump models are identified by the large red plastic pressure regulator.
- The AR30 & AR40 pump models are identified by the all metal pressure regulator.

The operating principles for both are very similar. See below example using AR252 pump.

- A. The suction line from the tank, to the ball valve.
- B. Ball valve. To the left (as shown) is drain, to the right is to the pump. Vertically up is OFF.
- C. Suction Filter. Check and clean frequently, and especially at the commencement of any spray program (best checked before chemical is added).
- D. Pressure Regulator – and surplus flow goes back to tank via (E) to aid agitation. The regulator also includes the pressure gauge.
- E. Return to tank. This line is also used for agitation.
- F. Spray line to the hose reel (s). Includes an on / off tap.

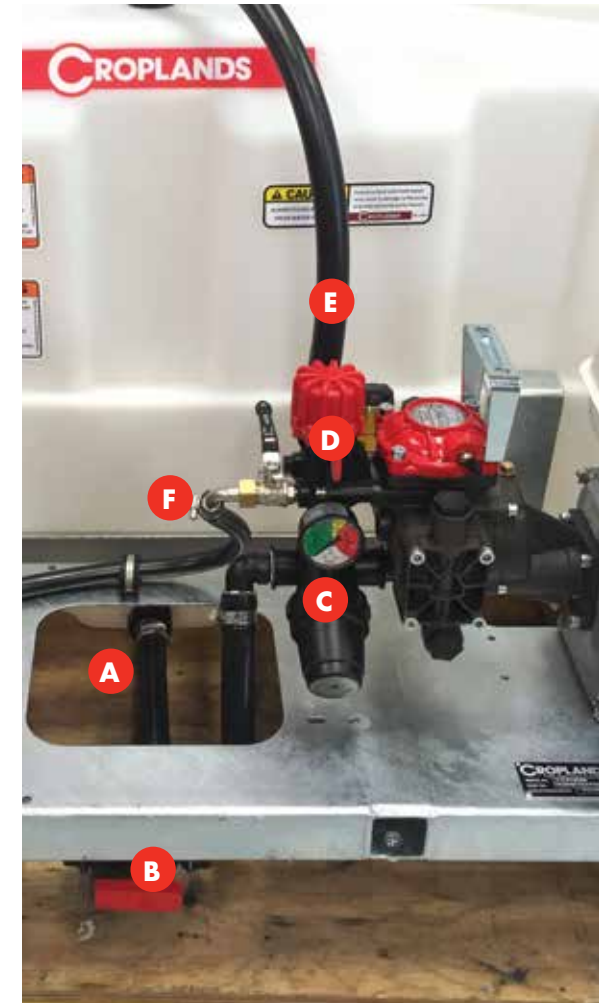

# SECTION 4B

## PRE-OPERATION - TRAYMOUNT SPRAYER

Note the ball valve has 3 positions, with vertical up as OFF. It's suggested the user connect a hose to the drain side of the valve and route the hose to a convenient place for safe draining of the tank.

- Be careful to dispose of any chemical in an environmentally responsible manner.



### AR252 Pressure Regulator (ARGR30)

The top portion of the Pressure regulator (**red arrow**) is used to set the pressure required. Turn clockwise to increase the pressure and anti-clockwise to decrease the spray pressure. Note the AR252 pump is rated to a maximum of 25 Bar pressure.

In the example shown the non-spraying pressure has been set to 12 Bar (**green arrow**). Take note of where the maximum of 25 Bar is located on the pressure gauge (in the green sector).

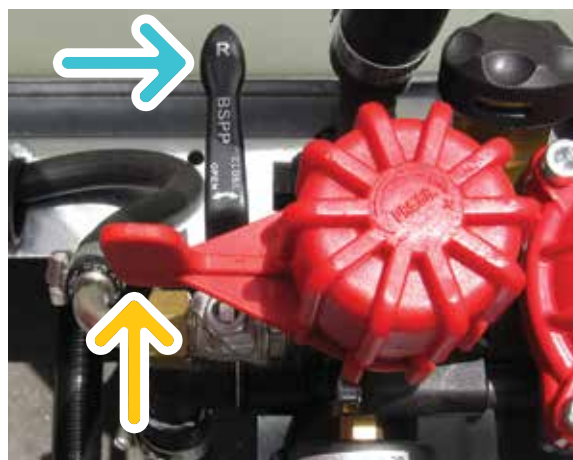
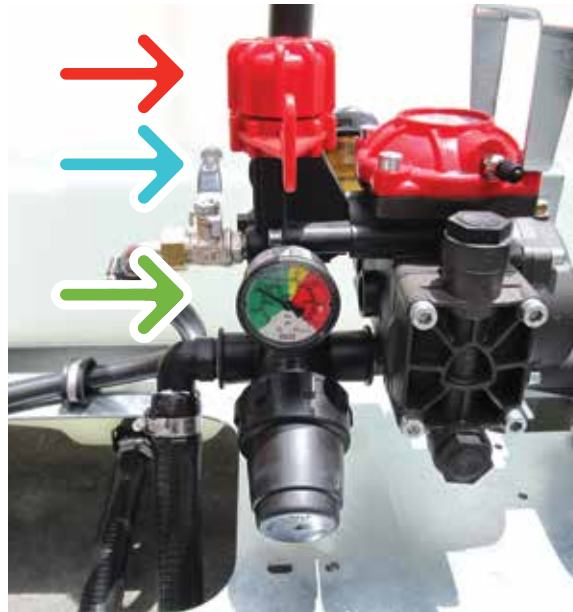

To bypass the pressure line & /or send spray / agitation back to tank, rotate the lower level of the pressure regulator to the position shown (**yellow arrow**).

Note in these 2 photo's the spray line tap is in the off position (**blue arrow**).

### AR30 / 40 Pressure Regulator (ARGI40)

In the example shown the regulator has been set ready to spray (level arm is down) and the pressure has been set to 18 Bar.

The regulator has 2 places for pressure adjustment.

Course adjustment is via the wire / notches – see the (**purple arrow**).

Use positions ....

- 1 for up to 10 Bar,
- 2 for up to 20 Bar,
- 3 for up to 30 Bar,
- 4 for up to 40 Bar.



# SECTION 4B

## PRE-OPERATION - TRAYMOUNT SPRAYER

Fine adjustment is via the brass knob. Disengage the PRV lever (see green outline) before adjusting the brass knob as pointed, Up (increase pressure) or Down (decrease pressure).



Disengaging the lever also activates the bypass / "dump" to tank / agitation.

Note the AR30 & 40 are rated to a maximum of 40 Bar pressure which correlates to the top of the green sector of the gauge. Never operate in the yellow or red sectors.



### Agitation

Note the volume of agitation from liquid bypassing the regulator (whilst spraying) is determined by the difference between pump performance (pressure) and the selected spray pressure.

### SPRAY GUN

Motorised Traymount sprayers are supplied with the Turbo 400 Spray Gun, with 1.5mm nozzle.

Practice the operation of the gun with fresh water before undertaking any chemical spraying.

Controls are a hand-held trigger, side lever for spray pattern (red arrow) and sliding / adjustable cone.

The side lever is used to adjust for cone or straight stream spray. Slide the orange cone forwards for a "fogging" type spray.





# SECTION 4B

## PRE-OPERATION - TRAYMOUNT SPRAYER

### SPRAY GUNS AND ACCESSORIES

For more information on accessories etc consult the Croplands Compact sprayers & components guide.



### FILLING, FILTERS & DRAINING

It's important to keep all filters clean. A careful, common sense approach to water quality, mixing of chemicals and care of filters, hoses and tank will ensure trouble free spraying.

Filling is via the lid, filtered via the basket – be very careful to not splash chemical when filling.



Draining is via the ball valve, with the tap pointing to the left (as shown). It's suggested the user connect a hose to the drain side of the valve and route the hose to a convenient safe place for draining the tank.

# SECTION 4B

## PRE-OPERATION - TRAYMOUNT SPRAYER

- Take care to dispose of chemical in an environmentally responsible manner.

Suction lines are fitted with a filter. The type, size and mesh vary from model to model. All meshes are colour coded and, in most cases, alternative mesh sizes are available via spray shops.

Red = 32 mesh (course) - not used from the factory.

Blue = 50 mesh

Yellow = 80 mesh

Green = 100 mesh (fine)



### PRE-OPERATION CHECK-LIST

Before operating the sprayer:

- Familiarise yourself with all supplied manuals.
- Check the sprayer is securely mounted.
- Check that the spray tank is clean, and drain tap is not open.
- Check that the suction line filter is clean.
- Check the hose reel / spray gun are correctly fitted, and in good condition.
- Fill the hand wash tank (if fitted) with clean fresh water.
- Check all plumbing and fittings are tight and not damaged. Fill the sprayer tank with clean water - making sure the basket filter is in place when filling. Check for leaks.
- **Safety Manual** ... has been read, understood and appropriate preparations have been implemented.

### INITIAL START-UP PROCEDURE, MOTORISED SPRAYER

Always use fresh water for familiarisation, maintenance, testing or training. If the unit has seen chemical, always wear safety gloves (as a minimum precaution).

Engine & pump check:

The Honda GX200 engine will have been pre-checked for operation at the factory. However, it is recommended you check the oil level as per the Honda manual.



# SECTION 4B

## PRE-OPERATION - TRAYMOUNT SPRAYER

Check the oil level in the pump. Pumps, oil requirements and fill positions vary from model to model – check the manual supplied for each unit.



Familiarize yourself with the engine controls – choke, on/off, engine speed control and starter pull-chord.



### First Time Start-up

This example is with AR252 pump model. The routine steps are the same – controls will vary from pump to pump and PRV.

- Oil checks done, correct & adequate fuel.
- Fill the sprayer with some clean water (50 litres would be sufficient for initial familiarisation).
- Set the PRV to “Bypass” lever as shown (**yellow arrow**), and ball valve to the reel in the off position, as shown (**blue arrow**).

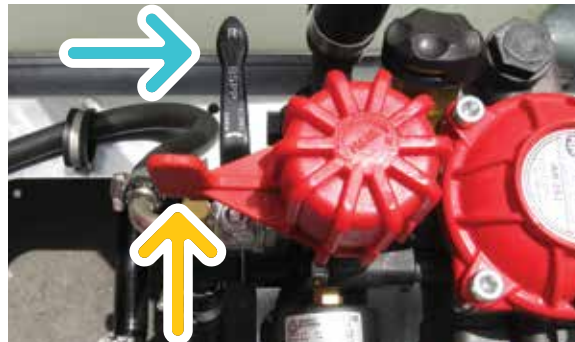

As a starting point set the PRV pressure adjustment knob to approximately 4 turns UP (low pressure). All units are tested and adjusted at the factory before delivery, so take note of the original setting. On AR30 / 40 pumps, set PRV to the first wire – lever up / bypass mode)

- Turn on the Honda’s ignition.
- Set choke to ON. Note hot starts don’t need the choke.
- Set run speed to Minimum (see image)
- Pull Start, usually 2 times is sufficient.
  - If not starting after 4 or 5 pulls, turn off the choke and set the throttle to full power. Will usually start first time. If all else fails, consult the Honda manual.



- Once the engine is running reliably at approximately ¼ power ....
  - Confirm that the pump has primed and is working (flow will be bypassing back to tank).
  - Turn on the pressure valve, **as circled**. For the AR30 it’s lever down.



# SECTION 4B

## PRE-OPERATION - TRAYMOUNT SPRAYER

- o Adjust the pressure until you have the required pressure, say 12 Bar **as circled**.
- o Turn on the ball valve to the hose reel / spray gun / boom, **as circled**.



### To Spray

Hold down the hand grip lever of the spray gun. Once the unit is spraying clean water, adjust the engine power until the operating pressure (whilst spraying) is at the required level. While the hand gun is spraying, check that the:

- o Nozzle spray pattern is even, adjusting the spray pattern to suit the application you are planning to carry out.
- o Pump pressure is constant and within the limit of the maximum pressure rating.
- o Release the hand grip lever to stop spraying.



- For spot spraying applications, the required pressure will vary significantly depending on the application and equipment used (boom, lance, gun). Whilst checking the sprayer with fresh water, also check for the maximum pressure likely to be used / checking for leaks etc.



### SHUT DOWN

Note see section 5 for more information on **cleaning & flushing**.

### Spray to empty

- Always easier to shut down after spraying until the tank and hose lines are empty.
- Reduce engine power to idle.
- Turn off the engine by using the ignition kill switch.
- Turn off the fuel if leaving for some time.



# SECTION 4B

## PRE-OPERATION - TRAYMOUNT SPRAYER

### Shut down with tank partially full

- Reduce engine power to idle.
- Turn off the engine by using the ignition kill switch.
- Use the spray gun to relieve any residual pressure / liquid in the spray line. Do not leave hoses full of water in the heat of summer or the cold of winter.
- If the unit is not going to be used for spraying on the same day, drain the tank and drain the hose.



**When the tank becomes empty, the pump will continue to run. Running the pump dry temporarily will not cause damage. However, avoid letting the pump run dry for long periods.**

With the initial start-up procedure is successfully completed, the sprayer is ready for operation.

Go to section 5, Operation



# SECTION 5

## OPERATION

The pre-operation tasks must be completed before commencing spray-operations.

### SAFETY FIRST

Before progressing further,

- Read and understand the Safety Manual (part no. GP-SAFE-A) supplied with this sprayer.
- Read and understand this manual to better familiarise yourself with the sprayer.

### DAILY START UP PROCEDURE

To ensure trouble free operation, follow the procedure below at the start of each new spray session:

- Check that suction line filter is clean and not damaged. It should be checked & cleaned regularly. Be careful not to damage or deform the mesh or O-Ring while cleaning and refitting the suction line filter. If a filter screen is damaged, replace with a new screen.
- Put enough clean water into the spray tank to operate the pump and hand gun.
- Activate the pump and ensure it primes correctly - hold the spray gun / lance trigger down, until the hand gun sprays steadily.
- Adjust the pressure relief valve to obtain the required pressure. Excess liquid will bypass back to the tank. Once the pressure is set, it is normal for minor fluctuations to show on the pressure gauge when switching the hand gun on & off.
- Check that all hoses, hose clamps and connections do not leak. Repair or replace damaged components.

**CAUTION**

**Do not add chemicals to the spray tank until the initial start-up or daily start-up procedure has been carried out. This avoids having a tank full of toxic chemical and the finding a sprayer problem.**

- Read and follow the instructions on the chemical manufacturers label before mixing and adding chemicals to the spray tank.
- Add chemical to the tank, as per below and proceed with your spray application.

### ADDING CHEMICAL TO THE SPRAY TANK

The steps for adding chemical to the tank are:

1. Calculate the amount of chemical required.
2. Part fill the spray tank with water.
3. Measure and pre-mix the chemical.
4. Add the pre-mixed chemical to the tank.

#### Step 1: Calculate the Amount of Chemical Required (Also refer Section 6)

To add the correct amount of chemical to a tank, it is necessary to calculate the amount of chemical required.

The method of calculating the amount of chemical required for the sprayer tank is dependent on the chemical rate recommendations. Use the information supplied on the chemical label to determine the tank mix concentration.

If you are unsure of the mix required, ALWAYS check with a qualified advisor or the supplier of the chemical you intend to use.

**CAUTION**

**Always follow chemical label instructions. When handling chemicals always wear protective clothing, ie. gloves, face mask, spray suit.**

#### Step 2: Part Fill the Spray Tank with Water

Part fill the sprayer tank with clean water.

Use fresh water (preferably rainwater), free of suspended organic matter or clay. Some chemicals are deactivated when they contact these materials. Ensure water quantity is sufficient to allow correct product blending.

**NOTE**

**Be sure to mix only enough spray mixture to cover the area required. Mixing too much chemical creates unnecessary waste and costs.**

**WARNING**

**Should chemical come in contact with skin immediately rinse off with water. Always follow chemical label safety instructions.**



# SECTION 5

## OPERATION

### Step 3: Measure & Pre-Mix the Chemical

Read and follow the instructions on the chemical manufacturers label before mixing & adding chemicals to the spray tank.

Chemicals should be accurately measured and thoroughly premixed in a separate container before adding to the spray tank:

- Measure out the required liquid chemical in a graduated measuring cylinder or bucket.
- Add chemical to a small volume of water in a container and thoroughly mix the chemical

### Tank Agitation

It's important to use chemicals that remain in solution whilst in a Traymount spray tank. The tank can only be agitated by the bypass side of the Pressure Regulator unit. For this reason, it's important to make sure the pump is generating (slightly) more pressure than required for spraying ... if the pump is not generating enough pressure there will be no bypass/agitation.

### Step 4: Add the Chemical to the Tank

Always make sure the filling basket is in place when adding water or chemical to the tank.

To add the premixed chemical to the tank:

- Add the pre-mixed chemical to the tank, thoroughly rinsing the chemical pre-mix container and adding the rinse to the tank.
- Top up the tank with water to the required volume.
- Close the tank lid securely.

### OPERATING THE SPRAY GUN

With the pump operating, and pressure regulator set, to operate the spray gun / spray lance:

- Aim the nozzle at the target area and hold down the hand grip lever to spray the target. Hold down the hand grip lever to spray and check that the:
  - Spray pattern is even.
  - Pump pressure is sufficient.

- If using a variable cone nozzle, adjust the cone to make the spray pattern required.

- Adjust the nozzle as required to completely spray the target.
- Use the hand gun trigger to turn the spray on & off as required.

When finished, switch off the pump. Relieve any residual pressure in the hose with a final use of the spray gun.

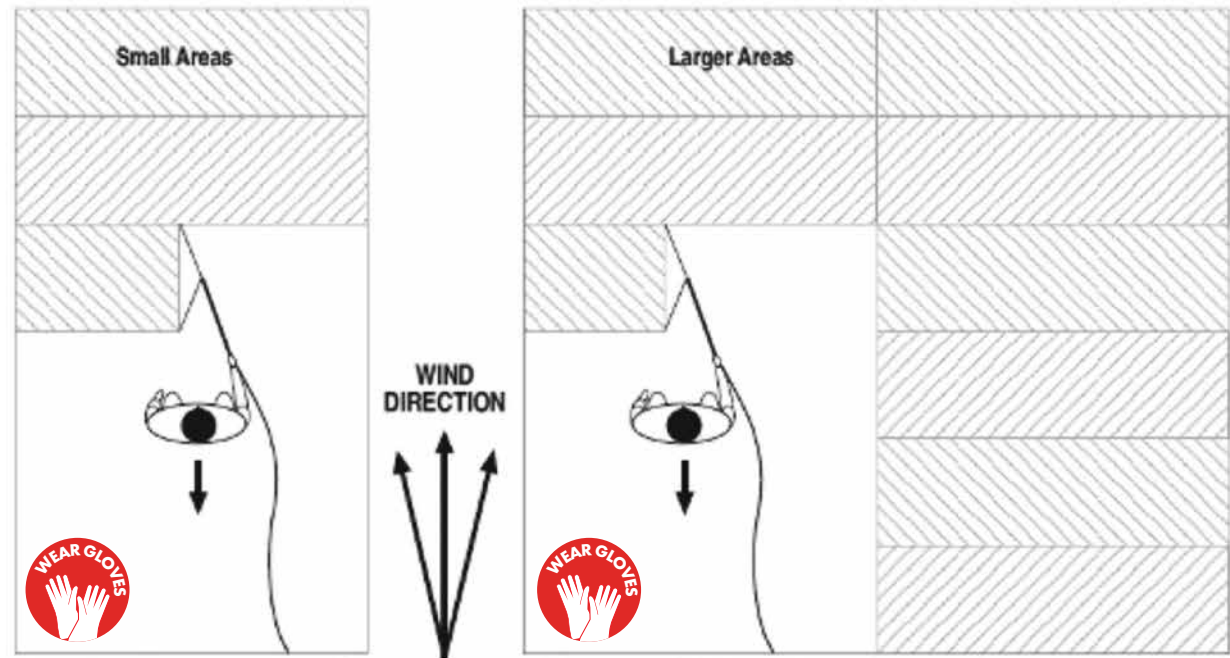

*In small areas, spray across the area & move back toward the wind.*

*In large areas, divide the area into smaller segments & move back toward the wind keeping track of the area sprayed to avoid under or overspraying.*

# SECTION 5

## OPERATION

### HAND GUN SPRAYING METHOD

It is always preferable to spray with your back toward the wind direction so that the wind carries spray away from the operator.

The operator should where possible, avoid walking on previously sprayed areas to avoid unnecessary fumes and contamination.

Operate with the sprayer situated behind the operator so that the hose from the sprayer can be kept on unsprayed areas.

This is important because the operator usually must handle, extend and rewind the hose many times, as he shifts from area to area. If the hose is kept relatively free from spray contamination, there is less exposure to chemical contamination.

### OPERATING POINTERS

Before spraying, make sure that it is safe to do so.

- The weather conditions must be suitable for hand spraying - always consider the spray drift.
- Be sure that bystanders and children are well away from the spray area and drift zones.
- Consider sign posting the chemical application area.

While spraying continually observe that:

- Adequate operating pressure is being maintained.
- Your hand gun coverage is correct and constant for effective cover.
- The nozzle is operating correctly.
- Periodically check and clean filters.
- Avoid going too slow because over application will occur. Conversely, avoid going to fast because under application will occur.

WARNING

**It is recommended to keep the hose from the sprayer on unsprayed ground and uncontaminated from the spray. This minimises contaminants on the hose and minimises exposure to chemicals when handling and rewinding the hose.**

## EMERGENCY ACTION PLAN

Never operate the sprayer without an action plan in place for when things go wrong ...

**“Take 5”** to evaluate the risks

Actions for most foreseeable machine issues such as breakages start with ...

**“Drop the speed”**

**“Dump the pressure”**

then evaluate further.

# SECTION 5

## OPERATION

### CLEAN & FLUSH THE SPRAYER

The Traymount sprayer should be thoroughly cleaned and flushed:

- Between chemical changes, and
- At the end of each day's spraying.

#### To completely flush and clean the sprayer:

- Remove the tank drain plug to drain spray mixture from the tank.
- Ensure drained mixture is disposed of as required by law. Read the chemical instructions.
- After chemicals have drained from the main tank, thoroughly rinse out the tank. Thoroughly clean the suction line filter & reassemble.
- Close the tank drain valve and add clean water to the tank to thoroughly flush the lines, pump and spray gun (and /or boom if fitted). Switch On the pump.
- Hold down the hand grip lever until all mixture is flushed out of the hose and hand gun / lance.
- On completion of flushing, release the trigger of the hand gun and turn the power switch off.
- Repeat steps 1 to 7 to more completely remove chemical residue from the tank and sprayer system.
- Wash/hose down the outside of the sprayer.



## CAUTION

**Always ensure the site for flushing and cleaning the sprayer meets with environmental and statutory regulations.**

### USING TANK & EQUIPMENT CLEANERS

If a cleaning agent is required (refer to chemical label), first completely flush the Sprayer with water as outlined previously.

#### To use the tank & equipment cleaner:

- Fill the spray tank approximately half full of freshwater.
- Add cleaning agent (use according to the manufacturer's instructions).
- Switch on the pump.
- Place the lance into the tank and hold down the hand grip lever to circulate cleaning fluid through the suction line, pressure line, hand gun and back to the tank.
- If you require the cleaning agent to soak or stand for a period, shut off the hand gun by releasing the hand grip lever and switch the power off.
- When soaking is completed, start the sprayer following steps 3 & 4 to flush the suction lines, pressure lines and hand gun.
- Stop flushing by releasing the hand grip lever and then switch the power off.
- Remove the spray tank drain plug and allow cleaning mixture to drain from the tank.
- Again, completely flush the sprayer with fresh water as outlined previously.
- Check the filter to ensure scale deposits are removed from the filter if they are present. Often the cleaning agent will dislodge chemical build-up from spray lines and fittings.



## CAUTION

**If you experience heavy frosts in your area, run the pump until the spray lines are dry after use. This will prevent damage from water freezing in the spray lines and pump.**



**ALWAYS FLUSH PUMP WITH FRESH WATER AFTER USE**

Failure to flush with fresh water may result in damage to the pump and reduced pump performance.

**CROPLANDS**





# SECTION 6

## SPRAYING INFORMATION & CALIBRATION

### WHEN TO SPRAY

Spraying results are best when the wind speed and the temperature are low, but the relative humidity is reasonably high. An ideal time is at sun up or nearing the end of the day when these conditions are more likely to occur.

For more information, contact Croplands about our SprayWise® program, or purchase a copy of the Nufarm SprayWise Application Guide from Croplands.

Also, the use of the WINDMATE™ Wind meter would be of excellent value to anyone doing regular spraying.

### USEFUL FORMULA

#### Calculating the Tank Spray Area

Use this formula to calculate the area each tank full of spray will cover.

$$\text{Area Covered (ha)} = \frac{\text{Tank Volume (litres)}}{\text{Spray Application Rate (l/ha)}}$$

e.g.  $\frac{250}{100} = 2.5 \text{ hectares}$

#### Calculating the Total Liquid Volume Required

Use this formula to calculate the amount of spray liquid required to spray a given area.

$$\text{Total Liquid Volume Required (litres)} = \text{Area (ha)} \times \text{Spray Application Rate (l/ha)}$$

e.g.  $2 \times 100 = 200 \text{ litres}$

### CALIBRATION - GENERAL

We should strive for the most efficient use of spray chemicals for effective pest and disease control. Consumer and public pressures to minimise residues, requires us to achieve the target application rate (uniform spray coverage without over or under spraying).

Applying the correct amount of chemical to a crop is only possible if the:

- Sprayer is calibrated correctly.
- Sprayer is maintained / operated correctly.

Correct chemical application rate can only be achieved if the variables of spray application are measured and controlled:

- Distance, time & working width are measured.
- Liquid & chemical volume applied.

This is done through sprayer calibration. Sprayer calibration is one of the single most important factors in establishing the correct application rate of the sprayer. Without calibration it is not possible to know the actual rate of spray application.

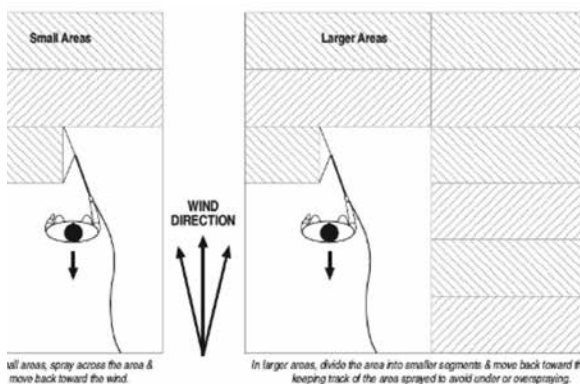

### SPOT SPRAYER CALIBRATION

See section 5 for hand gun / lance spraying method.

Traymount sprayers are most commonly used for spot spraying using a hand gun with a single variable cone or flat fan nozzle.

Precise application rates are not usually achieved with hand guns because the application rate is entirely dependent on the operator.

Two steps are recommended for calibrating a spot sprayer:

1. Choose the appropriate nozzle.
2. Check the nozzle operates correctly.

#### Choose the Appropriate Nozzle.

The nozzles used should be appropriate for the chemical being used. The standard adjustable ConeJet should suffice for general Glyphosate-based formulations & applications. Follow the chemical manufacturer's recommendation for any specific nozzle requirements as per the manufacturers label.

The standard lance has a removable cap, the adjustable ConeJet can be removed and most 80 and 110degree flat fan nozzles can then be used with the cap & seal.

The nozzle chosen must be within the flow capability of the pump fitted to the sprayer.



The Honda powered pumps have ample performance for most spray gun applications. The Turbo 400 gun comes standard with a 1.5mm nozzle. See chart overleaf for performance.

# SECTION 6

## SPRAYING INFORMATION & CALIBRATION

Pressure	15 Bar (200 psi)		25 Bar (350 psi)		35 Bar (500 psi)		40 Bar (600 psi)	
Spray pattern	Cone	Straight	Cone	Straight	Cone	Straight	Cone	Straight
Flow (L/Min)	4.6	5.1	5.7	6.5	6.6	7.4	6.9	7.8
Spray Angle (Degree)	25	x	28	x	28	x	28	x
Max Throw (Metre)	3	7	3.2	7.8	3.4	8.5	3.5	9.2

### SPRAY QUALITY

Spray quality is becoming extremely important for the correct application of chemicals. Refer to your advisor, local DPI or check the Croplands Buyers Guide for more information.

Many chemical labels now specify the spray quality required for the product being used. Loosely, spray quality falls into a droplet range of:

- » Ultra Coarse
- » Very Coarse
- » Medium
- » Very fine
- » Extremely Coarse
- » Coarse
- » Fine

### NOTE

**Most spray applications will fall into the Medium to Very Coarse range, depending on the application. Talk to a qualified Agronomist or advisor if uncertain.**

# SECTION 7

## MAINTENANCE & TROUBLESHOOTING

### DAILY MAINTENANCE

In the first few days of sprayer usage, thoroughly check the machine before starting each day of spraying.

- Check all nuts, bolts and tank tie downs.
- Check plumbing for leaks.
- Check all safety guards and decals are in place.

#### Pump - Honda-powered AR models

- Check the oil level on the pump sight gauge and top up with SAE 20/40 multi grade engine oil if needed.

#### Filters

- It is important to clean filters daily as they can have a major impact on your sprayer's performance. Wash them out with a soft brush and constantly check for holes or tears. Clean the suction filter every time the tank is filled and at the end of the days spraying. Make sure O rings are in good condition and grease them with O ring grease in necessary. Clean out nozzle filters if installed.

#### Spray lines

- Never leave chemicals in the tank or the pump. Rinse the tank out completely with fresh water and operate machine to clear all spray lines. Remove boom tube caps if you have a boom fitted and flush the boom lines.

### 20 HOURS MAINTENANCE

- Grease the reel swivel if fitted / needed.

### NOTE

**Also refer to your Honda Manual supplied with your sprayer for engine maintenance.**

### ANNUAL MAINTENANCE

In addition to daily maintenance.

#### General sprayer care

When spraying season has finished, clean the machine completely.

- For winter storage, if freezing conditions are expected, empty pump completely and flush with a mixture of water and antifreeze to prevent unrepairable damage to your unit.

#### Pump - Honda-powered AR models

- Flush and drain the pump completely before storage.
- Check the valves and diaphragms for wear and damage before the start of the new season. Set the air pressure in the chamber to around 10 – 20% of the usual operating pressure.



**Do not leave water in the machine, particularly in cooler climes as this can freeze and ruin the pump.**

- Drain the oil before the commencement of the next season and replace completely with new oil (SAE 20/40 multi grade engine oil).

# SECTION 7

## MAINTENANCE & TROUBLESHOOTING

### Troubleshooting Pump Problems

PROBLEM	PROBABLE CAUSE	REMEDY
<b>A. Failure to Prime</b> - motor operates, but no pump discharge.	1. Restriction in intake or discharge line.	1. Open all line valves, check for “jammed” check valve poppets & clean clogged lines.
	2. Air leak in intake line.	2. Fix air leak in intake line.
	3. Punctured pump diaphragm.	3. Replace pump diaphragm.
	4. Defective pump check valve.	4. Repair or replace pump check valve.
	5. Crack in pump housing.	5. Replace pump housing.
	6. Debris in filter or check valve.	6. Clean filter or check valve.
<b>B. Motor Fails to Start</b>	1. Consult the Honda owners manual	
<b>C. Low Flow and Pressure</b>	1. Blocked suction filter.	1. Clean the suction filter.
	2. Air leak at pump intake.	2. Repair air leak on the pump intake.
	3. Accumulation of debris inside pump & plumbing.	3. Clean the inside of the pump and plumbing.
	4. Worn pump bearing (excessive noise).	4. Replace pump bearing.
	5. Punctured pump diaphragm.	5. Replace pump diaphragm.
	6. Defective rectifier or motor.	6. Replace rectifier or motor.
<b>D. Pulsating Flow</b> - Pump Cycling On and Off.	1. Restricted pump delivery.	1. Check discharge lines, fittings, valves & spray nozzles for clogging or undersizing.
	2. Nozzle too small.	2. Ensure nozzle is correct size.
<b>E. Motor stops unexpectedly</b>	1. Run out of fuel	1. Allow motor to cool down before topping up with fuel & restarting.

# SECTION 8

## ASSEMBLY DRAWINGS

**ALL PARTS INFORMATION is now listed on the Croplands website:**

- Go to [croplands.com.au](http://croplands.com.au)
- Search in the Parts Information section linked to the home page.

### NOTE

Drawings are for illustration purpose only - refer to sprayer for actual plumbing. Parts listed are indicative of the sprayer type.  
Items in italics or without a part number are non stocked items and may need to be specially ordered.  
For further parts information refer to: [www.croplands.com.au](http://www.croplands.com.au)

### NOTE

Contact Croplands Technical Support for further information:  
**1300 650 724**

<b>200F/300F BASE ASSEMBLY</b>	<b>37</b>
<b>US20F/25/100R3</b>	<b>38</b>
<b>US30F/30/100R3</b>	<b>39</b>
<b>600F BASE ASSEMBLY</b>	<b>40</b>
<b>US60F/40/100RT3</b>	<b>41</b>
<b>US500/40/100RT3</b>	<b>42</b>
<b>WIRING SCHEMATIC</b>	<b>43</b>



# SECTION 8

## ASSEMBLY DRAWINGS

### 200F / 300F BASE ASSEMBLY

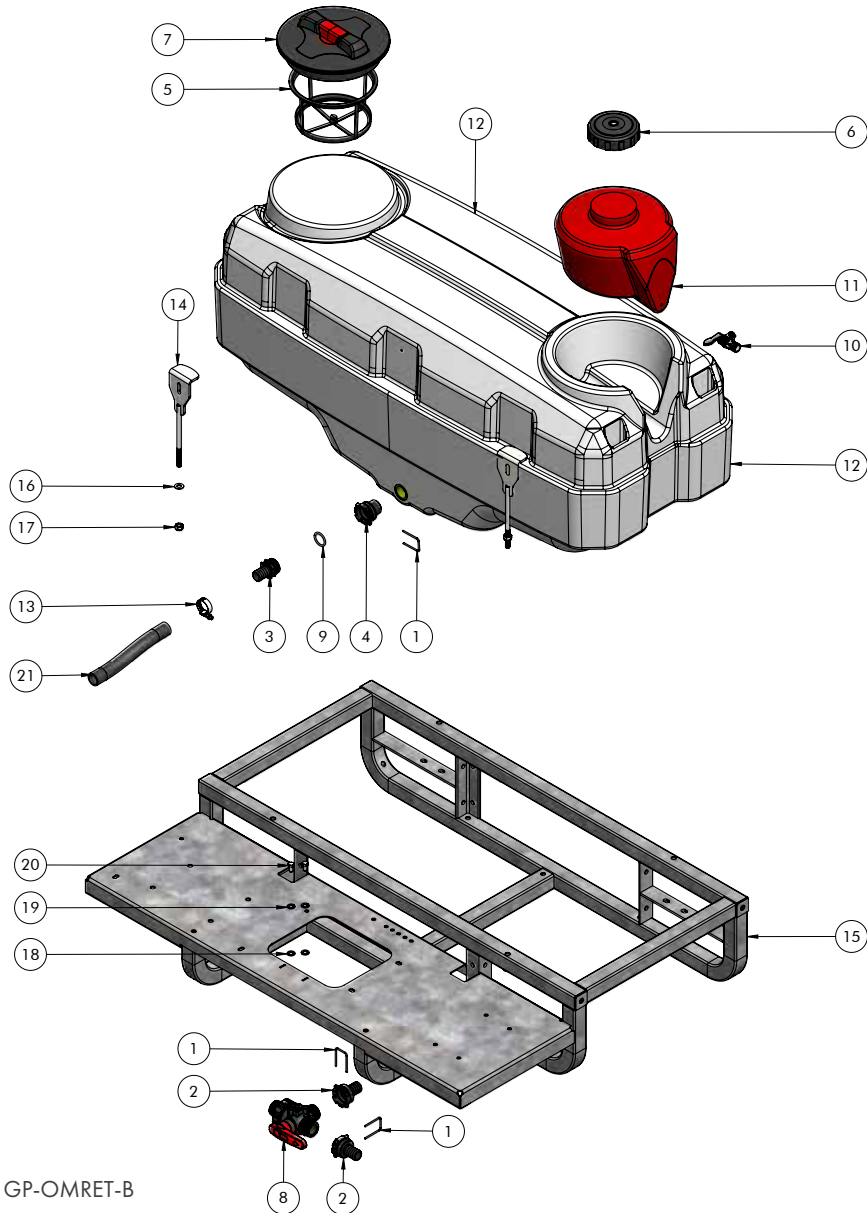

ITEM NO.	PART NUMBER	DESCRIPTION	QTY.
1	A010004	MANIFOLD FORK T4	3
2	A1090425	HOSETAIL 25MM	2
3	A1091425	HOSETAIL T4M D.25	1
4	A249044	HOSETAIL T4F 1"MALE	1
5	A300110	FILTER BASKET SMALL 115MM DEEP	1
6	A354030	LID 4" C/W BREATHER & SEAL	1
7	A3510221	LID/RING KIT 250MM	1
8	A45524444	BALL VALVE 3 WAY T4M	1
9	AG11054	O RING 25MM	1
10	B165.1501.5	BALL VALVE 1/2" X 1/2" RH	1
11	P200C-6L-RAW	TANK 6LT RTV HANDWASH	1
12	P200C-RAW	TANK 200LT RTV	1
	P300C-RAW	TANK 300LT RTV	option
13	TR1HC	HOSE CLAMP 25MM 1" WORM DRIVE	2
14	UP-306-2	TIE DOWN CLAMP 200/300	4
15	UP-307-1	FRAME TRAYMOUNT 200/300	1
16	M10FWASHER	M10 FLAT WASHER ZP	4
17	M10NNUT	M10 NYLOC NUT HT ZP	4
18	M8FWASHER	M8 FLAT WASHER ZP	2
19	M8SWASHER	M8 SPRING WASHER ZP	2
20	M8X16	M8 X 16 SET SCREW HT ZP	2
21	Tube_1-US200-FM1A	HEP25 SUCTION HOSE	235MM

## NOTE

Drawings are for illustration purpose only - refer to sprayer for actual plumbing. Parts listed are indicative of the sprayer type.

Items in *italics* or without a part number are non stocked items and may need to be specially ordered.

For further parts information refer to: [www.croplands.com.au](http://www.croplands.com.au)

Please contact Technical support for further details

# SECTION 8

## ASSEMBLY DRAWINGS

US20F/25/100R3

### NOTE

Drawings are for illustration purpose only - refer to sprayer for actual plumbing. Parts listed are indicative of the sprayer type. Items in *italics* or without a part number are non stocked items and may need to be specially ordered. For further parts information refer to: [www.croplands.com.au](http://www.croplands.com.au)

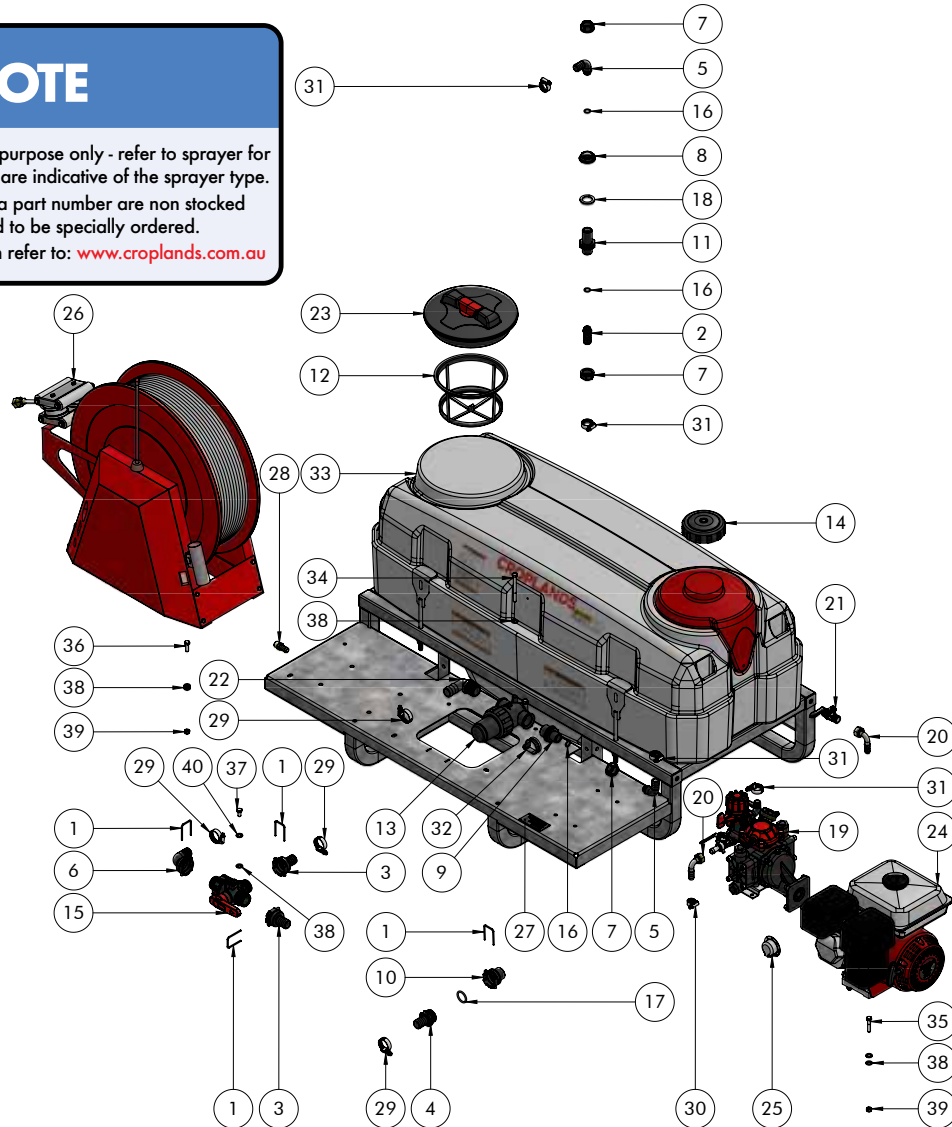

ITEM NO.	PART NUMBER	DESCRIPTION	QTY.
1	A010004	MANIFOLD FORK T4	4
2	A106320	TAIL 3/4" TO 20MM	1
3	A1090425	HOSETAIL 25MM	2
4	A1091425	HOSETAIL T4M D.25	1
5	A116320	ELBOW 3/4"	2
6	A1190425	ELBOW T4F D.25	1
7	A200030	FLY NUT 3/4"	3
8	A205030	BACK NUT 3/4"	1
9	A240034	NIPPLE 1" - 3/4" REDUCING	1
10	A249044	HOSETAIL T4F 1"MALE	1
11	A2502031	LONG THREAD NIPPLE 3/4"	1
12	A300110	FILTER BASKET SMALL 115MM DEEP	1
13	A3244043	FILTER 1" 50 MESH FEMALE THREAD	1
14	A354030	LID 4" C/W BREATHER & SEAL	1
15	A45524444	BALL VALVE 3 WAY T4M	1
16	AG10031	O RING 3/4"	3
17	AG11054	O RING 25MM	1
18	AG40003	FLAT SEAL 3/4" EPDM	1
19	AR252-CRGI	PUMP W/ GEARBOX & CONT 30826	1
20	B163.604.13	ELBOW 1/2" C/W HEX NUT 1/2"	2
21	B165.1501.5	BALL VALVE 1/2" X 1/2" RH	1
22	BJHB100-90	ELBOW 1 NPT X 1 BARB	1
23	G8149000	LID/RING KIT 255MM	1
24	GX200QX	MOTOR 6.5 HP HONDA	1
25	GX270-DEF	EXHAUST DEFLECTOR GX270	1
26	RSRL3-100RC	HOSEREEL 100M RH WITH REMOTE	1
27	S/NO	SERIAL NUMBER PLATE	1
28	TFA3812	TAIL BRASS 3/8" BSPM X 1/2 TAIL	1
29	TR1HC	HOSE CLAMP 25MM 1" WORM DRIVE	4
30	TR12HC	HOSE CLAMP 20MM 1/2" WORM DRIVE	1
31	TR34HC	HOSE CLAMP 20MM 3/4" WORM DRIVE	5
32	TRSGU138W5	P CLAMP 38MM RUBBER SLEEVE S/S	1
33	US200-FM1A	TANK AND FRAME 200LT RTV V2	1
34	M8X85BOLT	M8 X 85 HEX HEAD BOLT HT	2
35	M8X40BOLT	M8 X 40 HEX HEAD BOLT HT ZP	4
36	M8X25	M8 X 25 SET SCREW HT ZP	4
37	M8X16	M8 X 16 SET SCREW HT ZP	2
38	M8FWASHER	M8 FLAT WASHER ZP	22
39	M8NNUIT	M8 NYLOC NUT HT ZP	10
40	M8SWASHER	M8 SPRING WASHER ZP	2

Please contact Technical support for further details

# SECTION 8

## ASSEMBLY DRAWINGS

US30F/30/100R3

### NOTE

Drawings are for illustration purpose only - refer to sprayer for actual plumbing. Parts listed are indicative of the sprayer type.

Items in *italics* or without a part number are non stocked items and may need to be specially ordered.

For further parts information refer to: [www.croplands.com.au](http://www.croplands.com.au)

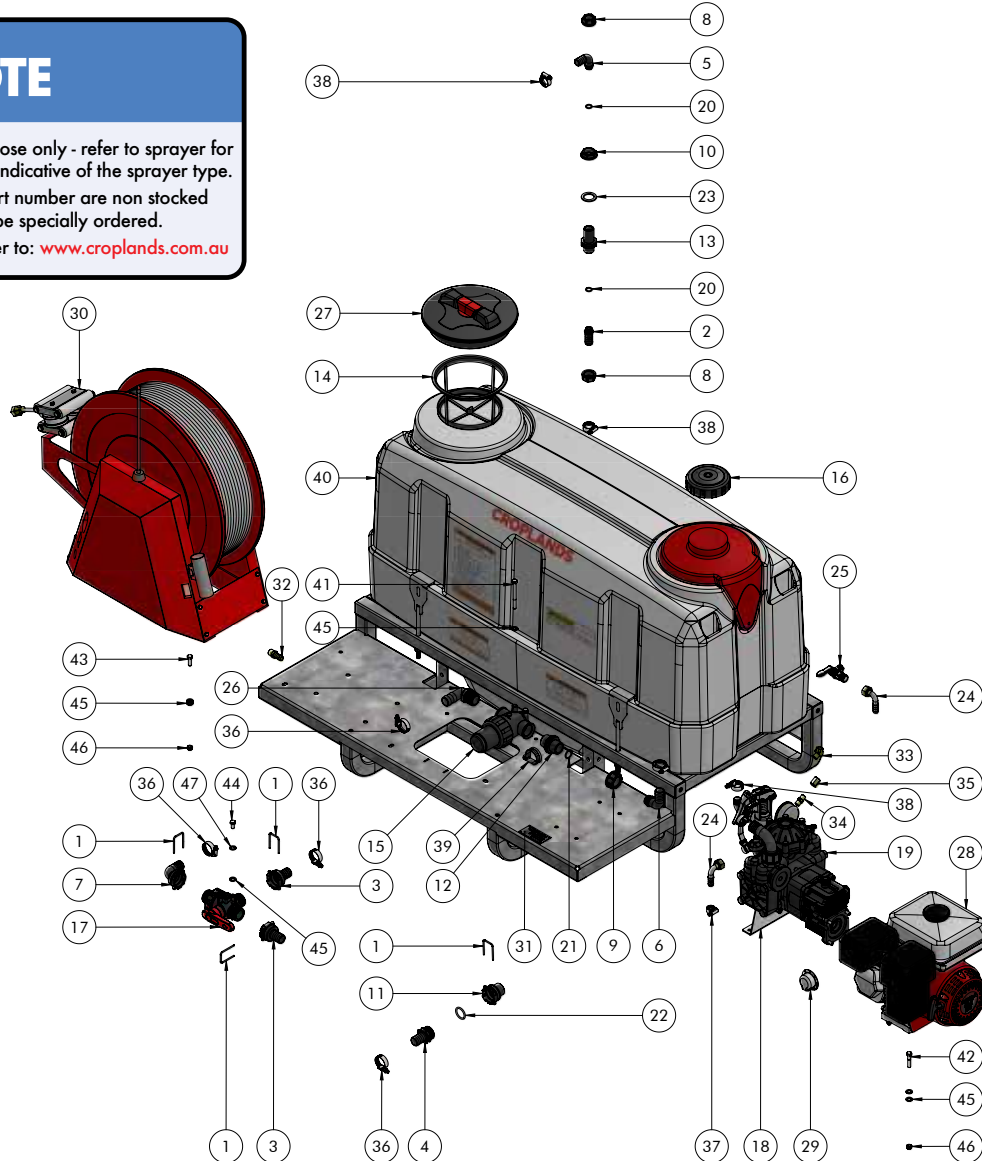

ITEM NO.	PART NUMBER	DESCRIPTION	QTY.
1	A010004	MANIFOLD FORK T4	4
2	A106320	TAIL 3/4" TO 20MM	1
3	A1090425	HOSETAIL 25MM	2
4	A1091425	HOSETAIL T4M D.25	1
5	A116320	ELBOW 3/4"	1
6	A116425	ELBOW 0.25 FOR FLY	1
7	A1190425	ELBOW T4F D.25	1
8	A200030	FLY NUT 3/4"	2
9	A200040	FLY NUT 1"	1
10	A205030	BACK NUT 3/4"	1
11	A249044	HOSETAIL T4F 1"MALE	1
12	A250040	NIPPLE 1"	1
13	A2502031	LONG THREAD NIPPLE 3/4"	1
14	A300110	FILTER BASKET SMALL 115MM DEEP	1
15	A3244043	FILTER 1" 50 MESH FEMALE THREAD	1
16	A354030	LID 4" C/W BREATHER & SEAL	1
17	A45524444	BALL VALVE 3 WAY T4M	1
18	AR30BRKT	AR30 MOTORIZED PUMP STAND	1
19	AR30-CRGI	PUMP AR30 GEARBOX & CONT	1
20	AG10031	O RING 3/4"	2
21	AG10041	O RING 1"	1
22	AG11054	O RING 25MM	1
23	AG40003	FLAT SEAL 3/4" EPDM	1
24	B163.604.13	ELBOW 1/2" C/W HEX NUT 1/2"	2
25	B165.1501.5	BALL VALVE 1/2" X 1/2" RH	1
26	BJHB100-90	ELBOW 1 NPT X 1 BARB	1
27	G8149000	LID/RING KIT 255MM	1
28	GX200QX	MOTOR 6.5 HP HONDA	1
29	GX270-DEF	EXHAUST DEFLECTOR GX270	1
30	RSRL3-100RC	HOSEREEL 100M RH WITH REMOTE	1
31	S/NO	SERIAL NUMBER PLATE	1
32	TFA3812	TAIL BRASS 3/8"BSPM X 1/2 TAIL	1
33	TFEL14MF45DEG	ELBOW 1/4" M/F 45DEGREE	1
34	TFM1414	NIPPLE 1/4" BRASS	1
35	TFS1414	SOCKET 1/4" BSPF	1
36	TR1HC	HOSE CLAMP 25MM 1" WORM DRIVE	5
37	TR12HC	HOSE CLAMP 20MM 1/2" WORM DRIVE	1
38	TR34HC	HOSE CLAMP 20MM 3/4" WORM DRIVE	4
39	TRSGU138W5	P CLAMP 38MM RUBBER SLEEVE S/S	1
40	US300-FM1A	TANK AND FRAME 300LT RTV V2	1
41	M8X85BOLT	M8 X 85 HEX HEAD BOLT HT	2
42	M8X40BOLT	M8 X 40 HEX HEAD BOLT HT ZP	4
43	M8X25	M8 X 25 SET SCREW HT ZP	4
44	M8X16	M8 X 16 SET SCREW HT ZP	2
45	M8FWASHER	M8 FLAT WASHER ZP	22
46	M8NNUT	M8 NYLOC NUT HT ZP	10
47	M8SWASHER	M8 SPRING WASHER ZP	2

Please contact Technical support for further details

# SECTION 8

## ASSEMBLY DRAWINGS

### 600F BASE ASSEMBLY

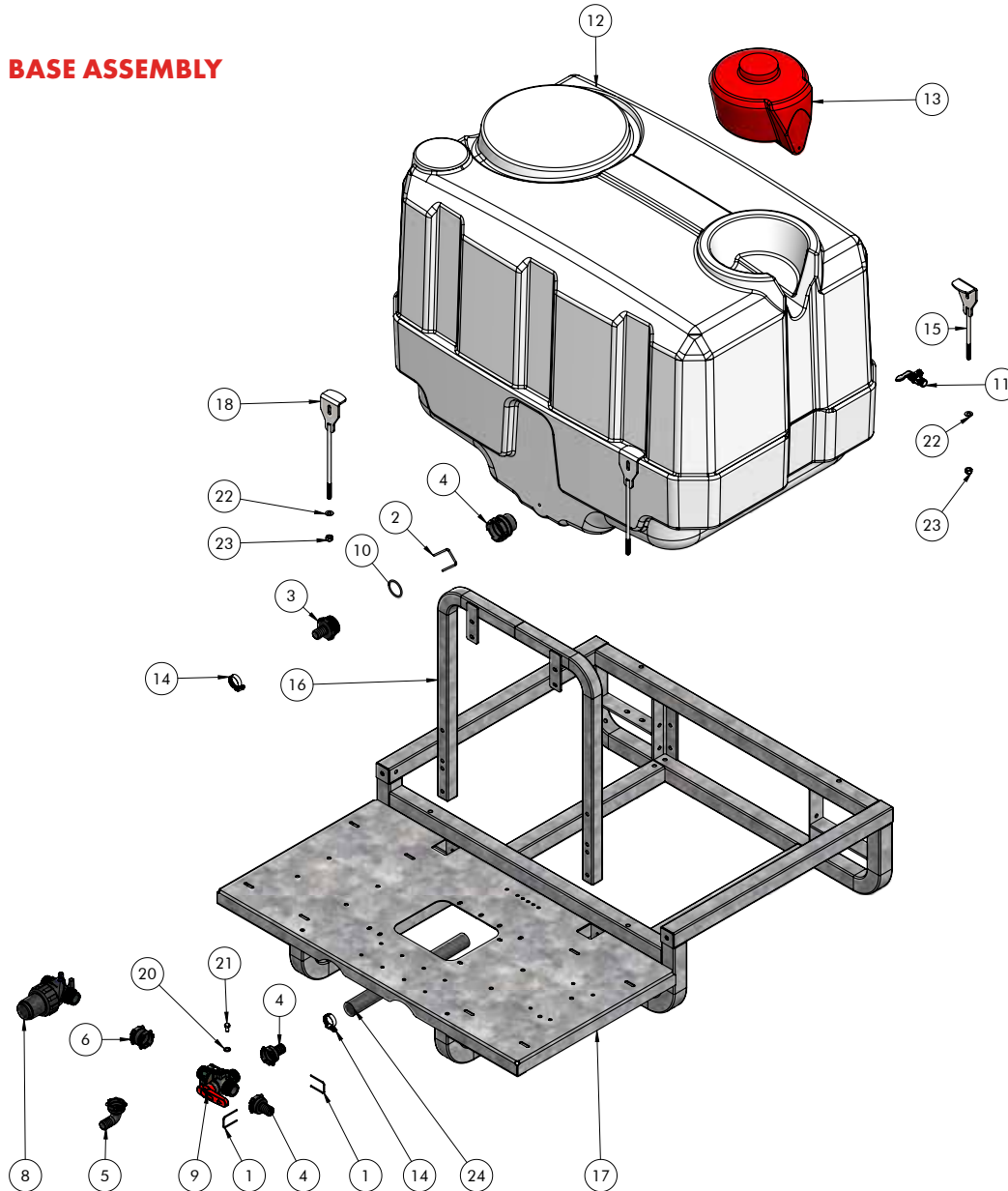

ITEM NO.	PART NUMBER	DESCRIPTION	QTY.
1	A010004	MANIFOLD FORK T4	2
2	A010006	FORK 453 SERIES T6	1
3	A 1091625	HOSE BARB T6M TO 1" BARB STRAIGHT	1
4	A 1090425	HOSETAIL 25MM	2
5	A 1190425	ELBOW T4F D.25	1
6	A259044	SOCKET T4F	1
4	A249066	OUTLET 1 1/2" MALE 453 SERIES	1
8	A32240C3	LINE FILTER	1
9	A45524444	BALL VALVE 3 WAY T4M	1
10	AG11023	O RING	1
11	B165.1501.5	BALL VALVE 1/2" X 1/2" RH	1
12	P600B-RAW	TANK 600LT RTV	1
13	P200C-6L-RAW	TANK 6LT RTV HANDWASH	1
14	TR1HC	HOSE CLAMP 25MM 1" WORM DRIVE	2
15	UP-306-2	TIE DOWN CLAMP 200/300	2
16	UP-306-5	HOSE REEL BRACKET	1
17	UP-308-1	RTV FRAME 600LT V2	1
18	UP-308-2	TIE DOWN CLAMP 600	2
19	M8FWASHER	M8 FLAT WASHER ZP	2
20	M8SWASHER	M8 SPRING WASHER ZP	2
21	M8X16	M8 X 16 SET SCREW HT ZP	2
22	M10FWASHER	M10 FLAT WASHER ZP	4
23	M10NNUT	M10 NYLOC NUT HT ZP	4
24	Tube	HEP25 SUCTION HOSE	450

## NOTE

Drawings are for illustration purpose only - refer to sprayer for actual plumbing. Parts listed are indicative of the sprayer type.

Items in *italics* or without a part number are non stocked items and may need to be specially ordered.

For further parts information refer to: [www.croplands.com.au](http://www.croplands.com.au)

Please contact Technical support for further details



# SECTION 8

## ASSEMBLY DRAWINGS

US60F/40/100RT3

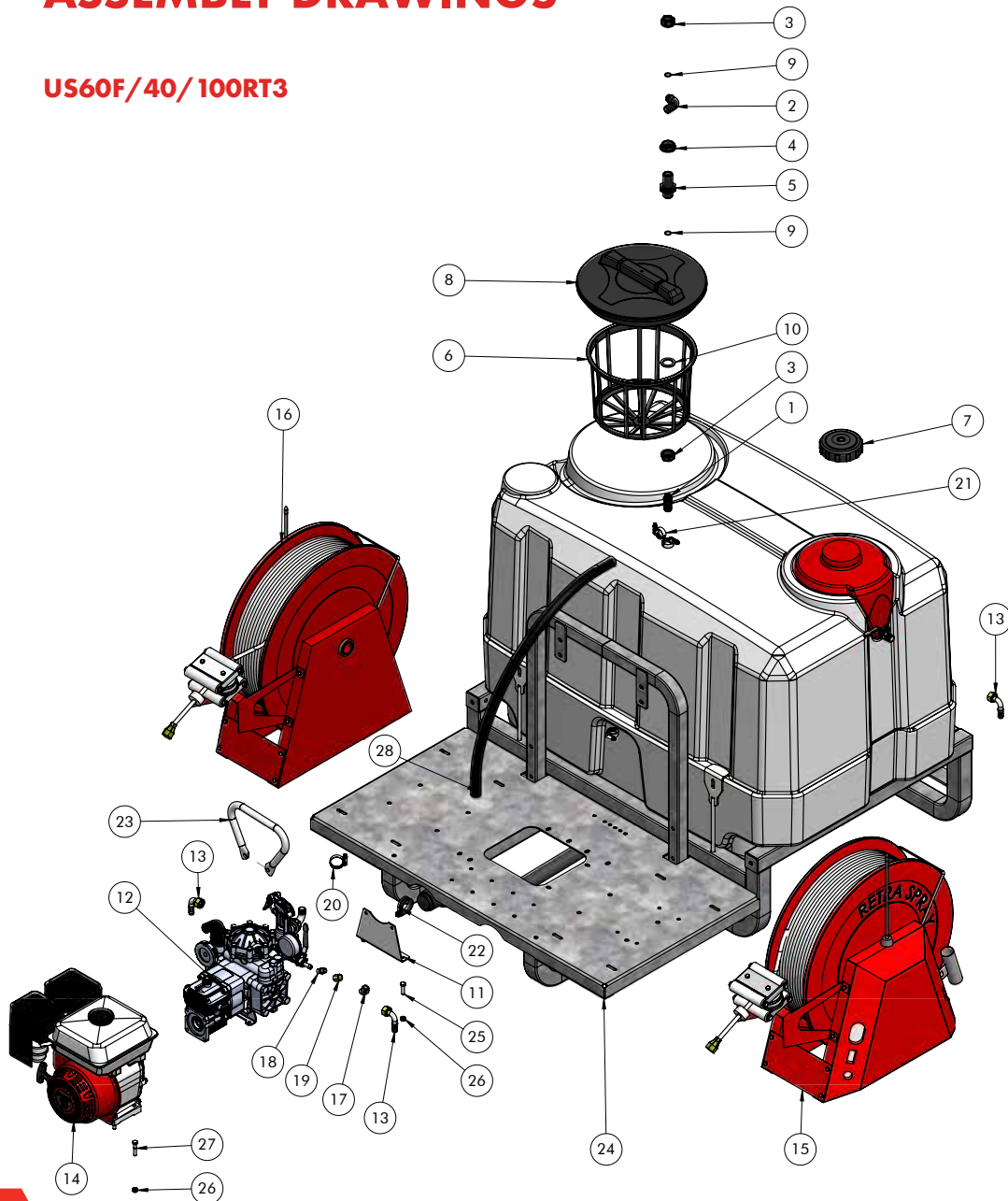

ITEM NO.	PART NUMBER	DESCRIPTION	QTY.
1	A106320	TAIL 3/4" TO 20MM	1
2	A116320	ELBOW 3/4"	1
3	A200030	FLY NUT 3/4"	2
4	A205030	BACK NUT 3/4"	1
5	A2502031	LONG THREAD NIPPLE 3/4"	1
6	A300120	FILTER BASKET MEDIUM 254MM DEEP	2
7	A354030	LID 4" C/W BREATHER & SEAL	1
8	A3510040	LID/RING KIT 355MM	1
9	AG10031	O RING 3/4"	2
10	AG40003	FLAT SEAL 3/4" EPDM	1
11	AR30BRKT	AR30 MOTORISED PUMP STAND	1
12	AR40_CRG1	PUMP AR40 GEARBOX & CONT	1
13	B163.604.13	ELBOW 1/2" C/W HEX NUT 1/2"	3
14	GX200QX	MOTOR 6.5HP HONDA	1
15	RSRL3-100RC	HOSEREEL 100M RH WITH REMOTE	1
16	RSRL3L-100RC	HOSEREEL 100M LH WITH REMOTE	1
17	TFEL14MF45DEG	ELBOW 1/4" M/F 45DEGREE	1
18	TFM1414	NIPPLE 1/4" BRASS	1
19	TFS1414	SOCKET 1/4" BSPF	1
20	TR1HC	HOSE CLAMP 25MM 1" WORM DRIVE	1
21	TR34HC	HOSE CLAMP 20MM 3/4" WORM DRIVE	3
22	TRSGU138W5	P CLAMP 38MM RUBBER SLEEVE S/S	1
23	UPHANDLE	HANDLE FOR MOTORISED AR19/30	1
24	US600-FM1A	TANK AND FRAME 600RTV V2	1
25	M8X30	M8 X 30 SET SCREW HT ZP	2
26	M8NNUT	M8 NYLOC NUT HT ZP	6
27	M8X40BOLT	M8 X 40 HEX HEAD BOLT HT ZP	4
28	Tube_4-US600_30_HR30TG	HEP25 SUCTION HOSE	700MM

### NOTE

Drawings are for illustration purpose only - refer to sprayer for actual plumbing. Parts listed are indicative of the sprayer type.

Items in *italics* or without a part number are non stocked items and may need to be specially ordered.

For further parts information refer to: [www.croplands.com.au](http://www.croplands.com.au)

Please contact Technical support for further details

# SECTION 8

## ASSEMBLY DRAWINGS

US500/40/100RT3

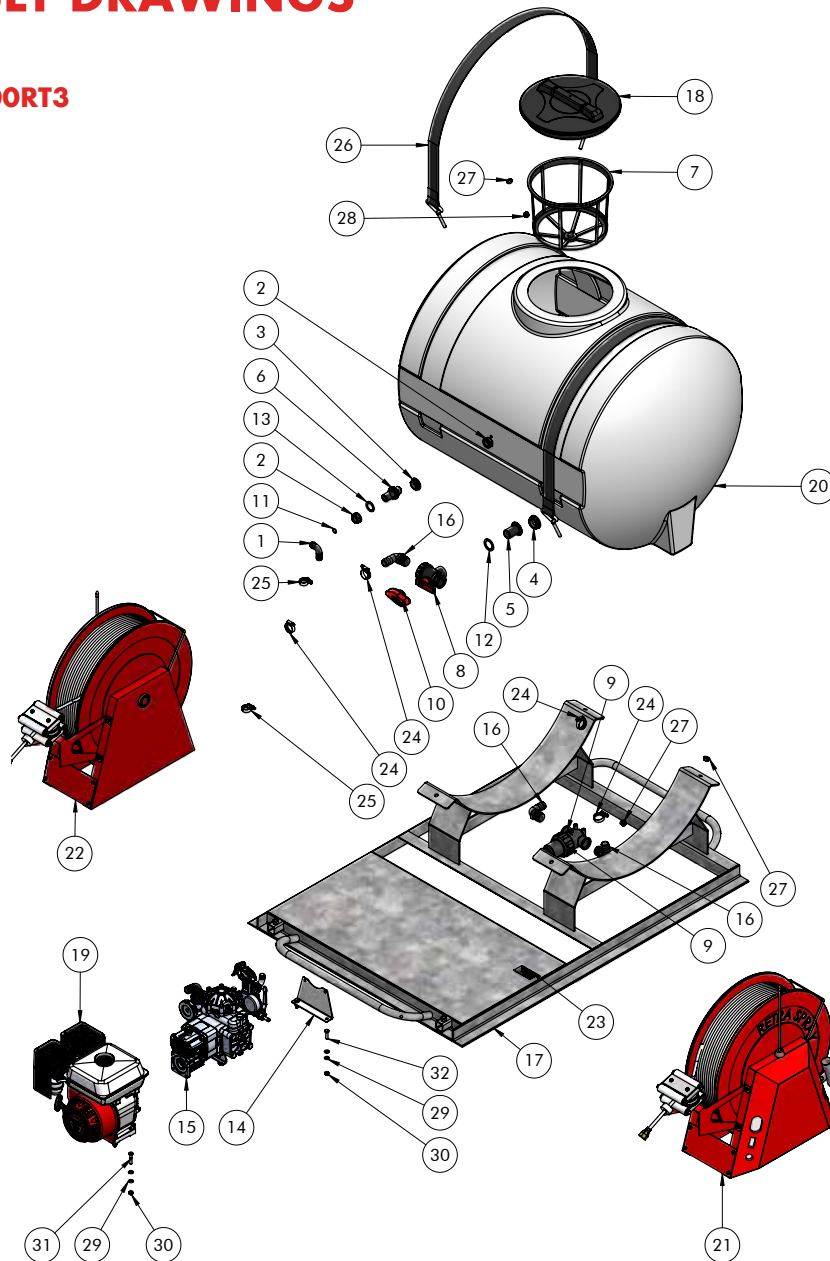

ITEM NO.	PART NUMBER	DESCRIPTION	QTY.
1	A116320	ELBOW 3/4"	2
2	A200030	FLY NUT 3/4"	2
3	A205030	BACK NUT 3/4"	1
4	A205040	BACK NUT 1"	1
5	A220040	TANK OUTLET 1"	1
6	A2502031	LONG THREAD NIPPLE 3/4"	1
7	A300120	FILTER BASKET MEDIUM 254MM DEEP	1
8	A454234	BALL VALVE POLY 1" 3 WAY	1
9	A3244043	FILTER 1" 50MESH FEMALE THREAD	1
10	A45300400T.050	T HANDLE VALVE RED DN25	1
11	AG10031	O RING 3/4"	2
12	AG40004	FLAT SEAL 1" EPDM	1
13	AG40015	FLAT GASKET 27.5X39.5X5 EPDM	1
14	AR30BRKT	AR30 MOTORISED PUMP STAND	1
15	AR40_CRGI	PUMP AR40 GEARBOX & CONT	1
16	BJHB100-90	ELBOW 1" - 1" BARB	3
17	BP-221BA	SKID CHASSIS 550LT	1
18	G8155000	LID/RING KIT 355MM	1
19	GX200QX	MOTOR 6.5HP HONDA	1
20	P600-RAW	TANK 550LT POLY RAW W/O FITTING	1
21	RSRL3-100RC	HOSEREEL 100M RH WITH REMOTE	1
22	RSRL3L-100RC	HOSEREEL 100M LH WITH REMOTE	1
23	S/NO	SERIAL NUMBER PLATE	1
24	TR1HC	HOSE CLAMP 25MM 1" WORM DRIVE	4
25	TR34HC	HOSE CLAMP 20MM 3/4" WORM DRIVE	3
26	XTRAP1800	TANK STRAP 1800MM	2
27	M10FWASHER	M10 FLAT WASHER ZP	4
28	M10NNUT	M10 NYLOC NUT HT ZP	4
29	M8FWASHER	M8 FLAT WASHER ZP	12
30	M8NNUT	M8 NYLOC NUT HT ZP	6
31	M8X40BOLT	M8 X 40 HEX HEAD BOLT HT ZP	4
32	M8X30	M8 X 30 SET SCREW HT ZP	2

### NOTE

Drawings are for illustration purpose only - refer to sprayer for actual plumbing. Parts listed are indicative of the sprayer type.

Items in *italics* or without a part number are non stocked items and may need to be specially ordered.

For further parts information refer to: [www.croplands.com.au](http://www.croplands.com.au)

Please contact Technical support for further details

# SECTION 8

## ASSEMBLY DRAWINGS

### WIRING SCHEMATIC

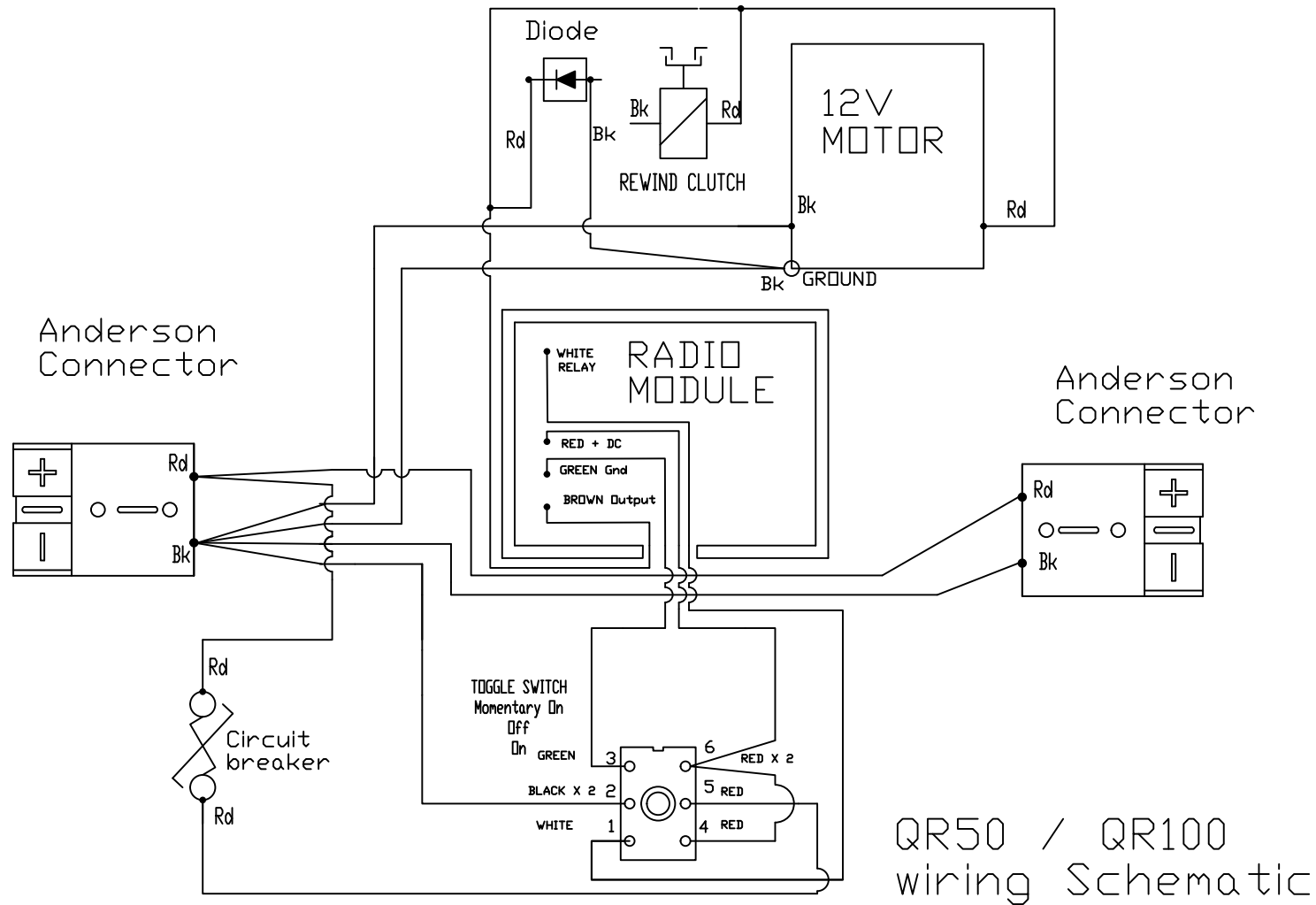

QR50 / QR100  
wiring Schematic

# SECTION 9

## INDEX

- Aerial** 16, 17, 20
- Agitation** 21, 23, 30
- Assembly drawings & parts** 37 ~ 43
- Ball valve** 21, 22, 24
- Bystanders and children** Safety Manual, 6, 31
- Calculate chemical quantities** 29, 30, 33
- Calibration** 33
- Cautions** 4, 6, 8, 16, 17, 19, 28, 29, 32, 35
- Checklist (pre operating)** 25 ~ 29
- Chemical disposal** SM, 22, 25
- Chemicals – working with** Safety Manual, 24, 29 ~ 31
- Circuit breaker** 17, 20
- Cleaning the sprayer** 32, 35
- Contents** 3, 15, 37
- Croplands customer support** back cover, 37
- Daily start-up procedure** 29
- Dimensions** 13, 14
- Dip switches** 17 ~ 19
- Disclaimer** 2
- Drain** 8, 13, 21, 22, 24, 25, 28
- Electric reel** 7, 16 ~ 20
- Emergency action plan** 31
- Fill main tank** 24, 25, 29, 38 ~ 43
- Filters** 21, 24, 25, 29, 32, 35
- First time start-up** 25 ~ 27
- Flushing after spraying** 32
- Gloves & PPE** Safety Manual, 29
- Hand Gun** 11, 23, 24, 27, 30, 31, 33
- Hand wash tank & tap** 8, 38 ~ 42
- Hook-up** 16, 21
- Honda motor** 9, 11, 25 ~ 27, 35, 36
- Important information** 4, 5
- Left-Hand reel** 7
- Lids & Lid basket** 8, 24
- Load & unloading** 6, 16, 21
- Maintenance** 20, 35, 36
- Manuals** 4, 6, 11, 36
- Notes** 4, 5, 29, 34, 35, 37 ~ 43
- Nozzle selection** 33, 34
- Nufarm** 2, 33
- Operational pointers** 19, 31
- Operator training & responsibilities** Safety Manual, 6, 25, 29, 31, 33
- Parts lists** Section 8, p.37 ~ 43 or Croplands.com.au
- Plumbing system description** 21 ~ 23
- Pressure gauge** 21 ~ 23
- Pressure regulator** 10, 21 ~ 23, 26, 27
- Prestart checks** 25, 26, 29
- Product identification & specification** - Section 3
- Pump information** 9, 10, 21 ~ 23, 26, 27
- Pump running dry** 28
- Quik Corp** 7
- Radio range & interference** 7, 16 ~ 20
- Receiver unit** 7, 17 ~ 20
- Remote control** 7, 18 ~ 20
- Roller guides** 7, 16, 19
- Safety instructions** 6, 29, 31
- Safety manual** 6
- Safety decals** 4, 6, 8, 21, 32
- Serial number** 8, 9, 10
- Spray Gun adjustment** 23
- Spray pressure** 21 ~ 23, 26, 27, 34
- Spray Lance** see hand gun
- Spray method** 23, 30, 31, 33
- Sprayer operation** 29 ~ 33
- Spraying on sloping or uneven ground** Safety Manual
- Spraywise** 33
- Storage of sprayer** 28, 32, 35
- Suction from tank** 21, 25
- Supa-Slip hose** 7, 16, 19
- Switch (main)** 17, 19, 20
- Table of contents** 3
- Tank & equipment cleaners** 32
- Tank level** 8, 13
- Transmitter tuning** 18
- Troubleshooting pumps** 11, 36
- 12-volt motor & connection** 7, 16
- Vehicle requirements** Safety Manual, 6, 21
- Warnings** 4, 6, 21, 29, 31
- Warranty** 5
- Weather conditions** 29, 31
- Working environment** Safety Manual



## **CROPLANDS**

### **AUSTRALIA**

Croplands Equipment Pty Ltd  
ACN 006 450 184

PO Box 2441  
Dry Creek  
50 Cavan Road  
Dry Creek SA 5094  
Australia

Freecall: 1800 999 162  
Freefax: 1800 623 778  
Email: [sales@croplands.com.au](mailto:sales@croplands.com.au)  
Website: [www.croplands.com.au](http://www.croplands.com.au)

### **NEW ZEALAND**

Croplands Equipment Ltd  
PO Box 2004,  
Stortford Bridge, Hastings 4120

Location:  
1422 Omaha Road,  
Hastings 4120  
New Zealand

Freecall: 0800 106 898  
Freefax: 0800 117 711  
Email: [sales@croplands.co.nz](mailto:sales@croplands.co.nz)  
Website: [www.croplands.co.nz](http://www.croplands.co.nz)

Your nearest Croplands Dealer  
can be found in the dealer section  
on the Croplands website