

CROPLANDS

OPERATORS MANUAL
**QUANTUM MIST
SMART SPRAYER**

INCORPORATING QM-420 SPRAY FANS

WWW.CROPLANDS.COM.AU

STOP

BEFORE COMMENCING
operation, **ENSURE** you read
& understand this manual, its
contents, and any additional
information supplied.



INTRODUCTION

GENERAL MANAGER'S WELCOME



A handwritten signature in black ink, appearing to read 'Sean Mulvaney'.

Sean Mulvaney
General Manager

Dear Customer

Congratulations on the purchase of your new Croplands Sprayer. Croplands have been in the business of building sprayer equipment since 1972. For 50 years we have been supplying sprayers to farmers, contractors, growers and all our customers involved in growing crops and in the control of pests and diseases.

Croplands is a wholly owned subsidiary of Nufarm Ltd, the largest supplier of crop protection chemicals for Australasia, and one of the fastest growing global suppliers world-wide.

At Croplands, we pride ourselves on our commitment to supplying machinery that is at the forefront of the industry's needs. We believe we can back up our products and through

constant research and development, bring to you the best equipment you can find.

We welcome any feedback from you about our equipment.

On the back cover you will find our contact details, and locations where our staff can be reached during business hours. After hours, you can email us and expect a reply the following morning.

Please read this manual in its entirety before you operate your sprayer. This will ensure you have a trouble free start up.

We trust you will get years of good use from your Croplands Sprayer.

Yours Sincerely

Sean Mulvaney
General Manager

Croplands has taken steps to ensure this operator's manual is as current and as accurate as possible. Due to the ever-changing markets of cropping and farming, Croplands is constantly striving to be at the forefront of innovation and technology. While the information in this manual is considered accurate at the time of writing, Croplands reserves the right to change this information without notice. Croplands will not accept liability for any inaccuracy in this publication, or changes forthwith.

CONTENTS

SECTION 1 **IMPORTANT INFORMATION**

About this manual	4
Terminology	4
Before Operating Your Sprayer	4
Warranty Policy	5

SECTION 2 **SAFETY**

Safety first	6
Safety signs and decals	7

SECTION 3 **PRODUCT IDENTIFICATION, SHIPPING & SPECIFICATION**

Product identification	8
Shipping information	8
General specification	9

SECTION 4 **PRODUCT FEATURES / FAMILIARISATION**

Quantum Mist QM-420 Spray fan	12
Fan frames, boom arms & tie rods	13
Hydraulic system	15
Spray pump	16
Fusion controller & connection	17
Windcomp hydraulics	19
Liquid system overview	20
Tanks & suction plumbing	20
Pump & pressure plumbing	22
Tiered spraying	24

SECTION 5 **PRE-OPERATION**

Safety first	28
Hook up	28
Fit & setup fusion controller to the tractor	31
Setup spray pressure	36
Set-up the booms	38
Set-up the Spray fans	41
Confirming fan functionality	42
Pre Operation Checklist	43

SECTION 6 **SPRAY OPERATIONS**

Safety first	45
Filters	45
Filling the sprayer	46
Setting sprayer pressure	46
Agitation	47
Mixing basket	47
Chemical suction probe	48
Calculate water & chemical quantities	49
Proceed to spray	50
Flushing	51
Tank and equipment cleaning	52

SECTION 7 **SPRAYING INFORMATION**

Spraywise	55
Calibration	55
Flowmeter calibration	56

Step 1 - ensure equipment is in good working order	56
Step 2 - determining the actual speed of travel	58
Step 3 - determine spraying volume required	58
Step 4 - determine sprayer configuration	58
Step 5 - determine the ideal spray pressure	59
Step 6 - determine & select correct nozzles	59
Step 7 - fit & test selected nozzles	60
Step 8 - calculate the actual application rate	60
Step 9 - if the tested rate is unsatisfactory	61
Step 10 - coverage assessment	62
Step 11 - add the correct amount of chemical to the tank	62
Step 12 - record all data for future reference	63
Calibration work sheet	64

SECTION 8 **SMART SPRAY RECAPTURE SYSTEM V2 68**

SECTION 9 **LUBRICATION & MAINTENANCE 69**

SECTION 10 **TROUBLESHOOTING 75**

SECTION 11 **ASSEMBLY DRAWINGS, PARTS & SCHEMATICS 79**

SECTION 1

IMPORTANT INFORMATION

ABOUT THIS MANUAL

This manual provides assembly, setting up, operating and maintenance instructions for the Croplands (Quantum Mist) SMART SPRAYER.

In addition to this manual, the sprayer will be delivered with the General Safety Manual (GP-SAFE-A), Fusion Controller Manual (HT-FUSION-A), Recapture system (if installed) HT-OMRECAP2-A and Micro Power Pack Manual (HT-OMMICRO-B). For details not covered by this Manual, please contact Technical Support.

Some features explained in this manual may not be installed on your sprayer.

Please pass on this manual with the sprayer at the time of resale for usage by the new owner.

This manual, HT-OMSMART-B, was first published in October 2022.

Check online as there may be more recent revisions of this manual.

TERMINOLOGY

These terms/symbols used throughout this manual:

NOTE	This Note sign is in place to convey useful information and will help you to identify the best possible way to operate the machine.
CAUTION	This Caution sign shows the potential for an incident. An incident may include damage to the machine itself, or possible injury to the operator.
WARNING	This warning sign shows the potential for risk or injury and highlights the need for steps to be taken to protect one's safety.
DANGER	This Danger sign will be used in areas where the highest risk is present. Always read the information on these signs and ensure you are taking steps to prevent risk or injury.

BEFORE OPERATING YOUR SPRAYER

Before attempting to use your sprayer, make sure you read all Operator Manuals for this sprayer including but not limited to:

This Operator's Manual, **and all other supplied manuals** for items such as Micro Power Pack, Pumps, PTO etc.

And properly understand:

- All Safety Issues.
- Assembly & Installation instructions.
- Calibration of the sprayer.
- Sprayer Operation.
- Sprayer Maintenance.

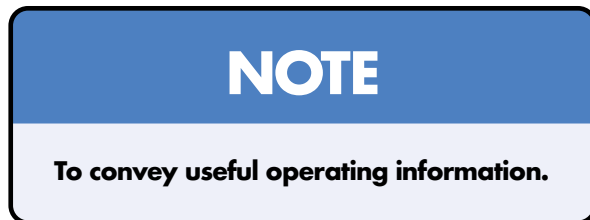

SECTION 1

IMPORTANT INFORMATION

WARRANTY POLICY

Each sprayer will be delivered with a Warranty & Pre-Delivery Booklet which includes:

- the Sprayer's unique serial number,
- the Sprayer's specification sheet,
- a pre-delivery checklist and
- outlines the Croplands Warranty policy.

Always contact your Croplands Dealer first and foremost for warranty matters.

NOTE

For full conditions of warranty and warranty policy, please see the Specification, Safety, Warranty & Delivery booklet provided with this sprayer.

SPRAYER SPECIFICATIONS SAFETY, WARRANTY & DELIVERY HORTICULTURE

WWW.CROPLANDS.COM.AU

CROPLANDS

STOP
BEFORE COMMENCING
operation, **ENSURE** you read
& understand this manual, its
contents, and any additional
information supplied.



GP-WARH-B

INCLUDES SAFETY INDUCTION

SECTION 2

SAFETY

SAFETY FIRST

Please read and understand all supplied manuals, guides and safety decals before operating this sprayer. This includes the **Croplands Operators Safety Manual** – as pictured here.

This manual is available on the Croplands Web site, or for printed versions contact Croplands customer support and ask for part number GP-SAFE-A (or later version if available).



SECTION 2

SAFETY

SAFETY SIGNS AND DECALS

All signs and decals for sprayer safety and operation must be maintained in good order and replaced if damaged or missing. Most Croplands labels have a part number printed on the decal to aid identification and replacement.

Some examples are shown below.

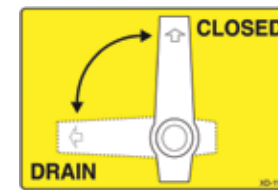

SECTION 3

PRODUCT IDENTIFICATION, SHIPPING & SPECIFICATION

PRODUCT IDENTIFICATION

Always use the serial number of the Sprayer when requesting service information or when ordering parts.

Early or later models (identification made by serial number) may use different parts, or it may be necessary to use a different procedure for specific service operations.

The serial numbers of all controllers, pumps etc should also be recorded for future reference.



SHIPPING INFORMATION

All provided tie down points (and more) should be used to help secure the sprayer for transporting.

Note serial number plate in the attached image.

Weights & Dimensions

The Croplands Smart Sprayer is available in 2000, 3000 and 4000 litre versions, all feature the QM-420 Spray



fans mounted in fan frames. Recapture screens and Micro Power Packs are optional.



Maximum **heights** can vary depending on tyres used, and ranges from 3.1m to 3.2m with 3.17m being the most common (top of inner arm). Terracing versions are 3.80m high.

Maximum lengths from rear of the fan frames to the ball joint of the Micro Power Pack (much the same position as a normal towbar) are:

- 2000 Lt = 4450mm (5150mm with Micro Power Pack)
- 3000 Lt = 4700mm (5400mm with Micro Power Pack)
- 4000 Lt = 5200mm (5900mm with Micro Power Pack)

Micro Power Pack (from centre of sprayer connection ball joint to linkage pickup points) is 700mm long.

Maximum widths, parked, from outside edge of the leaf guards will vary depending on the boom width being used – set at 2.5m row width the narrowest parked width is 2200mm, and with the boom extended to the maximum row width, the narrowest parked width is 2600mm.

Wide tower versions (depending on boom width and position of the parking bracket), the maximum width is 2990mm wide.

Weights (not including recapture)

- 4000 Lt with Micro Power Pack = tba
- 3000 Lt with Micro Power Pack = 2583 kg empty
- 2000 Lt with Micro Power Pack = tba

Weight of Micro Power Pack	= 190 kg
	+/- 10 kg

Weight of Inner Recapture	= 108 kg (pair)
Screens including Awning + external hardware & hoses	

Weight of Boom Recapture	= 124 kg (pair)
Screens including Awning + external hardware & hoses	

SECTION 3

PRODUCT IDENTIFICATION, SHIPPING & SPECIFICATION

GENERAL SPECIFICATION

The SMART Sprayer is Croplands premium vineyard sprayer that comes in double row and triple row configurations with optional Recapture / Drift Reduction System.

The Quantum Mist™ system uses a combination of individual hydraulically driven Spray fans with 5-blade fans to give the maximum possible spray coverage in grapes and dwarf tree crops.

All Smart Sprayers feature the Fusion Control system which allows for full electric over hydraulic control for many of the Smart Sprayer features.

For more detailed specification, see Section 4, Product Features / Familiarisation

Controls

The Fusion controller with integrated joystick is used to control all hydraulic (fan and boom) and spray functions.

Tank Sizes

2000, 3000 and 4000 litre tank options are available and are constructed of impact resistant polyethylene and UV stabilized. Each tank has an incorporated flushing tank and a calibrated sight tube for filling level indication.

All main tanks drain completely via a large drain valve and sump.

Chemical Handling

Quick fill (camlock) system and chemical suction probe standard on all models.

Filtration

Lid-strainers & chemical mixing baskets are standard on all

models. Large suction filter, self-cleaning pressure filter fitted.

Recapture system (when fitted) also incorporates inline filters.

Pumps

All Smart Sprayers are fitted with an Annovi Reverberi positive displacement diaphragm pumps with a capacity of 165 to 250 L/min - depending on the sprayer model.

A heavy duty PTO shaft is supplied to drive the pump. This will be supplied to suit the drawbar fitted.

Hydraulic driven pumps (in lieu of PTO) are also an option when a Micro Power Pack is fitted to the sprayer.

Agitation

The agitation system is driven by the pump via twin supra-flow venturi tank agitators & bypass agitation.

Hydraulic System

Hydraulic oil supply is from the tractor or Micro Power Pack.

The oil supply feeds to the main hydraulic control block from which the oil is distributed to the hydraulically driven fans and boom functions. The block also includes the main pressure relief valve, anti-cavitation valve, soft-start and test ports (pressure and return).

All models are fitted with a hydraulic oil radiator with thermostat switching of an electric fan cooler.

Micro Power Pack

Supplied as standard on all 18 x fan models,, optional for 12 and 8 fan models, the Micro Power Pack is a compact, independent oil supply system incorporated into a 3 point linkage, self-steering drawbar. Driven by the tractor

PTO shaft, the Micro Power Pack is available in single or dual pump configuration depending on Sprayer model specifications.

See separate manual for this option.



QM-420 Spray fans

The new QM-420 Spray fans "Fans", comprised of a Polyethylene Rotomoulded cowling which includes mounting points on either side, into which there are installed dual spray rings, front and rear safety guards and drive body & fan.

The 5-blade 420mm diameter fan has been designed for maximum air efficiency in the agricultural environment with excellent characteristics for canopy spraying.

The fans are hydraulically driven by a case drained 6.5cc or 9.8cc motor, driving via a double bearing "drive body" and shaft with well proven rubber coupling to smoothly drive the fan.

Nozzles

Each Spray fan comes with 2 spray rings with 5 nozzles per ring, for a total of 10 nozzles per fan. The nozzles are used in a 3 tier system, with low, medium and high volumes available.

SECTION 3

PRODUCT IDENTIFICATION, SHIPPING & SPECIFICATION

Standard nozzles are ALBUZ 80 degree ceramic hollow cone nozzles (brown and yellow).

The feed to all spray rings is fitted with a "non-drip" diaphragm check valve with integral stop cock.

Spray rate capability for the Quantum Mist™ Smart Sprayer ranges from 150 to 2000+ L/ha depending on nozzle options.

Boom & Fan Frame

Robust powder-coated, heavy duty steel booms support the galvanized "fan frames". Booms are position sensing and can be hydraulically folded to most conventional row widths required via the Fusion controller.

Spray fan orientation is controlled via a pull rod / parallelogram unit so that the fans remain square to the target and park flat against the sprayer for transport.

Rear/inner booms are manually adjusted.

All fan frames feature a breakaway system.

2-Row and 3-Row

Boom configuration for a two row sprayer is "normal", however the 2-Row, 2-Row with Recapture or 3-Row systems uses the unique "Hanger" style mounting (as shown) at the end of the boom arm.



Chassis

Hot-dipped galvanised full-length heavy-duty chassis with self-tracking drawbar, slide-out step & jockey stand.

Suspension

Walking beam tandem axle is fitted on all models.

Wheels & Tyres

11.5/80 x15.3 wheels with tubeless tyres are fitted as standard. Flotation tyres available as options.

Recapture System v2

An optional 2-row drift reduction & recapture system can be fitted to a 2-row QM Smart Spray. This is ideally suited to cooler climate vineyards.

The system is modular and can be removed if the benefit of drift control or recovery is not required.

Captured "over-spray" is returned to the sprayer tank via a second generation venturi suction system.

Refer section 8 for more details

Speed Sensors

Proximity sensors are used for Fan speed, Pump speed and wheel (travel) speed.

Tractor required

Power required at the PTO on flat terrain:

- 2-row - 40 HP
- 3-row - 65 HP
- 3-row / 18 fan / 4000 Lt - 90 ~ 100 hp

If not using a Micro Power Pack, hydraulic oil required will be dependent on sprayer model & configuration, ranging from 36 to 108 litres per minute at pressures up to a maximum of 2,750 psi.

Category 2 or 3 linkage connections required.

Factory Fitted Options

- Wide Tower – will be supplied for use in row widths greater than 3.0 metres (3.3 - 3.75)
- Recapture System (2-row only)
- Nozzles- AlbuZ 60-degree nozzles can be used in lieu of 80-degree.
ARAG 40-degree (ceramic hollow cone) nozzles are recommended with Optional Recapture system.
- Micro Power Pack (standard on all 18 fan models)
- Flotation tyres (31 x 13.5 – 15") – not compatible with the 2,000 Lt model
- Electric brakes
- Light kit
- Terracing tower
- Bio oil (for Micro Power Pack)
- Atlas 100 GPS speed sensor
- NuPoint GPS tracking, mapping and data reporting system

Machine specifications are subject to change without prior notification.

SECTION 4

PRODUCT FEATURES / FAMILIARISATION

QUANTUM MIST QM-420 SPRAY FAN “FAN”	12
FAN FRAMES, BOOM ARMS & TIE RODS	14
HYDRAULIC SYSTEM	15
SPRAY PUMP	17
FUSION CONTROLLER SYSTEM & CONNECTION	17
WINDCOMP HYDRAULICS	19
LIQUID SYSTEM OVERVIEW	20
TANKS & SUCTION PLUMBING	20
PUMP & PRESSURE PLUMBING	22
TIERED SPRAYING	24
REFER SECTION 8 FOR RECAPTURE SYSTEM	68

SECTION 4

PRODUCT FEATURES / FAMILIARISATION

QUANTUM MIST QM-420 SPRAY "FAN"

Standard on all QM Smart Spray models is the new extremely efficient 420 mm diameter "QM-420" fan.



Fan / Cap / Cover

The robust 5 bladed fan also features a separate moulded front cap designed to prevent the build-up of detritus so common in other fans, and the same cap, with the "knockout" removed, is used at the rear to further streamline the airflow.

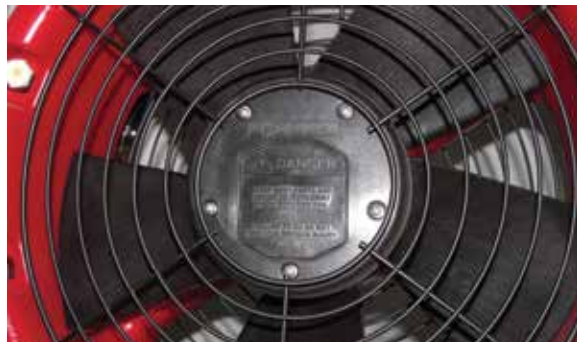

Drive Body

The drive body differs from the "original" and very reliable QM-380 drive body in that it has a further 4 tapped holes to accept the rear cover. Note the rear cover (which is the same moulding as the front cap, with a knock out for the hydraulic motor) has positions for 5 screws, but only 4 screws are used. The "5th screw" position aligns with a casting cutaway for either a speed sensor or case drain connection (see photo above and below).

Cowl Orientation / Speed Sensor / Case drain

The cowling should always be mounted with the cutaway for speed sensor or case drain facing downwards (to enable drainage). The case drain is there for the unlikely event of blowing oil seals in the hydraulic motor.

Sprayers fitted with the WindComp feature will use 2 speed sensors (left and right).

Note the rear guard needs to be removed to fit or access the speed sensor. Replace the guard once done.



Dual Spray Rings

The fan also features dual spray rings, with 5 nozzles per ring. This allows unprecedented control over spray coverage rates and droplet spectrums.

As supplied, it's set up as a 3-tier system. The inner / smaller diameter spray ring is fitted with a smaller (eg. brown) nozzle, and the outer / larger diameter spray ring is fitted with a larger (eg. yellow) nozzles.

- Inner spray ring only is **Tier 1** / lowest volume rate.
- Outer spray ring only is **Tier 2** / medium volume rate.
- Both spray rings together are **Tier 3** / for high volume rate.

There are many other ways to use the dual ring system such as using one of the rings for special purpose nozzles.

Hydraulic Drive

All QM-420 fans are driven by hydraulic motors built to a special heavy-duty specification and with case drain port. Most QM Smart Spray models are fitted with 6.5 cc motors. In some instances (if required) 9.8 cc motors can be used as an alternative.

SECTION 4

PRODUCT FEATURES / FAMILIARISATION

Fan Guards

The QM-420 must never be used without the front and rear guards installed.



Operational limits

The nominated maximum operating speed of the fan is 3,000 rpm. Normal delivered maximum operating speed of 2,500 rpm. Exceptions apply.



DANGER, Stay well away from rotating fans.

Whilst the front (downwind) side may appear to be the more dangerous side, it's the back side that holds greater danger as it can suddenly suck body parts or objects in.

Fan Frame Mounting

Each Spray fan is mounted via dual M12 brass inserts moulded into each side of the cowling.

The normal Spray fan mounting method is via special stainless-steel clamps into the "Fan Frame".

The bracket is reversible and can be used to adjust head positioning (see more page 41).

Check Valve / stop cock / drain

The feed to each spray ring is fitted with a "non-drip" diaphragm check valve with integral stop cock which allows individual spray rings to be manually shut off as required.

Screw the red cap **in for stop**, out for normal diaphragm "non-drip". Each spray ring has a draining / flush tap on the exit.

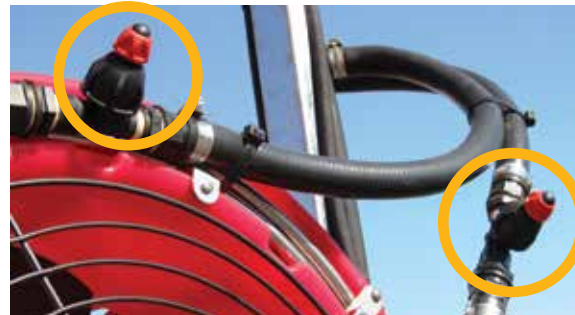

FAN FRAMES, BOOM ARMS & TIE RODS

Fan Frames

Mounting the fans into the fan frames has many advantages, including the ability to specify exact positioning of fan heights and angles. The fans remain well protected and fixed until a change is required.

Up to 3 fans can be installed in each fan frame – with the lower fan also using a leaf guard (not shown here)...

More about setting up and operating the fans (and booms) in Section 5.

Boom Configurations

All QM Smart Spray models use the same rear (inner row), width adjustable boom arms at the rear of the sprayer (Photo 1), with individual fan frames, connected via a breakaway swivel head.

2-Row Sprayers also use individual fan frames, connected via a breakaway swivel head at the end of the main boom arms (Photo 2).

3-Row sprayers use the same main boom arms, but instead of an individual fan frame at the end of the boom, a "Twin Hanger" is used to support a pair of fan frames at the end of the main boom arms. (Photo 3). One set of fans pointing

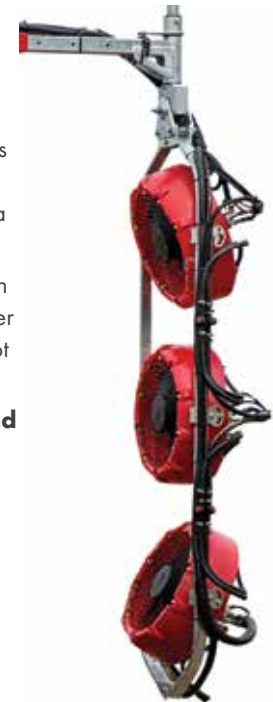

SECTION 4

PRODUCT FEATURES / FAMILIARISATION

inwards, the other set pointing outwards). A different "Hanger" is used for 2-Row + Recapture.



Photo 1



Photo 2



Photo 3

A parallelogram system via an adjustable push – pull rod keeps the fans pointing towards the canopy regardless of the boom arm position from parked through to fully open. In this way it's possible to adjust boom (row) width by rotating the boom.



Photo 4

Controlling the boom position and hence row width is via the Fusion control system.

The main boom arm is also adjustable for length (Photo 4), nominally suiting row widths from 2.5 to 3.4 metres via a series of adjustment holes in both the inner slide of the main boom and also the pull rod. **More details in Section 5.**



Photo 5

Each fan frame is connected to the boom arm or "Hanger" via a Swivel Head which incorporates the ability to breakaway by about 45 degrees.

All swivel heads and connections use bushes which are best used dry as grease will attract dust and dirt.

Whenever the Hanger system is used, the individual frames are connected at the bottom, via a tie rod to ensure both frames breakaway together (Photo 5).

Main Tower options

The standard Tower is supplied for use in vineyards with row widths from 2.5 to 3.0 metres. Whilst it's possible to spray wider row widths, turning with the fans in the parked position can become an issue (especially the 3 row versions).

SECTION 4

PRODUCT FEATURES / FAMILIARISATION

The (350mm each side) Wide Tower option (Photo 6) is the supplied option for rows of 3.3m and above.

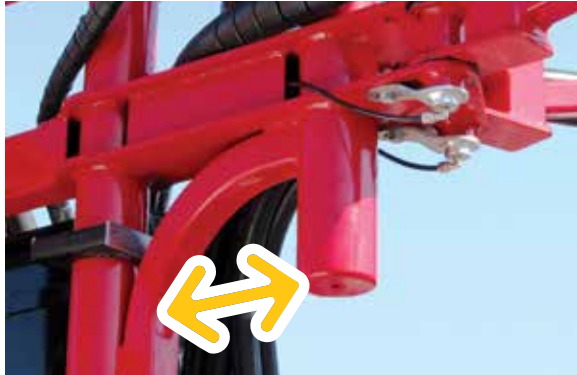

Photo 6

Boom Position Sensor

Each of the 2 main booms uses a boom position sensor, shown here (Photo 7). These boom position sensors have been factory calibrated to measure the booms working width. This allows varying row widths to be set from the cab via the Fusion controller.



Photo 7



HYDRAULIC SYSTEM

The Smart Sprayer using Fusion control employs quite different hydraulics from the Croplands "Classic" Quantum Mist Sprayer. The key difference is that each fan frame, be it 2 or 3 fans per frame, is its own separate hydraulic circuit **.

Assuming sufficient oil supply, this enables all fans to be run at (or near) maximum speed whilst keeping (relatively) low pressures and temperatures. Troubleshooting is also easier.

** Note in some markets (smaller tractors / not requiring a Micro Power Pack), the plumbing is more "traditional" using circuits of 4 or 6 fans.

For more details refer to the oil flow schematic.



Each circuit connects to a specially developed "Fusion" hydraulic block. All hydraulic boom functions, such as boom fold cylinders are also connected to the same block. Therefore, the operation of all functions connected to the main block are controlled by the Fusion controller (and joystick).

Note, to open and close boom arms require the Fusion controller and hydraulics to be activated.

Micro Power Pack

Most of the larger Quantum Mist Smart Sprayers will be equipped with the Micro Power Pack in one of 2 configurations, sized as is appropriate for your sprayer.

- Single pump or
- Dual pump.

There is a separate manual for the Micro Power Pack, **HT-OMMICRO-B**, first published in September 2021.

Safety; Always be aware of the PTO shaft.

SECTION 4

PRODUCT FEATURES / FAMILIARISATION

Oil Supply



There are two main options to supply hydraulic oil.

1. The preferred option is for oil supply via the PTO driven, **single pump, Micro Power Pack** (see separate manual), with the AR product (spray) pump driven via a separate tractor remote. This is the simplest most reliable and maximum performance setup. The most common Micro Power Pack single pumps are 48, 56 or 74cc.
2. Oil supply from **Tractor hydraulics** only. This is the most economical option and is satisfactory for smaller sprayers (2 row 8 fans or 12 fans). Note: very few tractors will have sufficient oil flow (and pressure) for the larger sprayers.



Oil Cooler

All Smart sprayers are fitted with a fan forced oil cooler. The fan is thermostat controlled, switching in at around 50 degrees C.

The Fusion system requires a separate wiring loom, direct from power source (tractor battery) to power the fan, part CHLOOM/AC.

WindComp

Wind Comp (wind compensation via independent Left/ Right fan speed control) is a feature made possible by the new "Fusion" hydraulic system. The fans facing left or right sides can be run independent of each other, at different speeds. This is ideal for combating cross winds or spraying in exposed / challenging conditions.

Refer "Fusion Controller Manual" for more details on Wind Compensation.

SPRAY PUMP

AR Pump

Smart Sprayers are fitted with an Anнови Reverberi positive displacement diaphragm pumps with a capacity of 165 or 250 L/min - depending on the sprayer model.

When a Micro Power Pack is fitted to the sprayer, the AR pump is driven by a hydraulic motor which is (preferably) connected to the tractor remotes (**yellow arrow below**) or via a secondary (dual) pump as a part of the Micro Power Pack (**blue arrow right**) – note the use of a separate manifold used to set and control the pump speed.

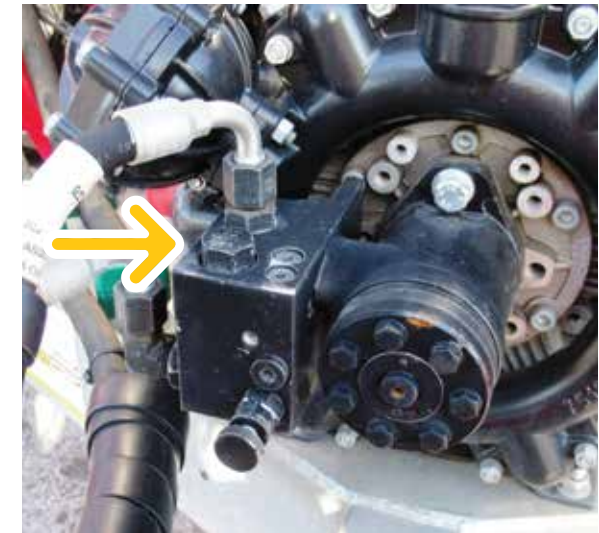

SECTION 4

PRODUCT FEATURES / FAMILIARISATION

For 18 x fan sprayer models the AR pump must be connected to tractor hydraulics.

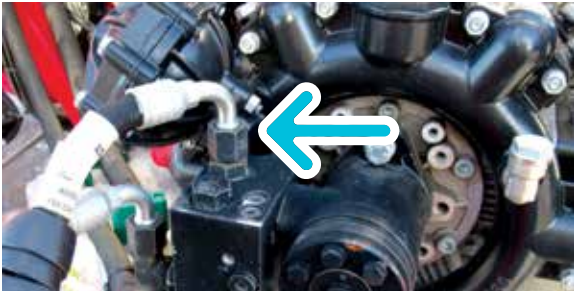

In sprayer models without a Micro Power Pack the pump is mounted to a 2 point or 3 point linkage self-steer drawbar and driven by a heavy duty PTO shaft. 3 point linkage pictured below.



FUSION CONTROLLER & CONNECTION

Quantum Mist Smart Sprayers come equipped with the Fusion Controller. The first truly intuitive controller designed for viticulture.

An Integrated joystick is used to control all sprayer and hydraulic functions.



CANBUS technology.

It allows for full electric over hydraulic control which allows for many of the new Smart Sprayer features.

From battery to cab is a power loom (MT90LOOM/PWR), and thereafter is the Fusion loom (CHLOOM-FUSION) which connects to the ECU module (mounted at the front of the sprayer).

The front end of the loom has 3 connections for:

- Console (12 pin)
- Joystick (6 pin)
- Updating port (4 pin) or optional Nupoint

Followed by a power lead which picks up the MT90LOOM/PWR.

Behind the cab is a connection to break tractor from sprayer – a handy way to make sure everything is off.

Note the section valves can draw a small current even with the controller turned off.



At the sprayer the loom connects to the ECU Module with 2 large pins.

From here are connections for:

- Micro Power Pack (level switch)
- Pump speed (pump is powered by tractor remotes)
- Flow meter
- Proximity or GPS Speed Sensor
- Spray "dump" / by-pass valve
- Flow Meter
- Pressure Transducer
- Tank level (optional)

SECTION 4

PRODUCT FEATURES / FAMILIARISATION



At the rear of the sprayers there are connections for ...

- Section valves (8 Neg switching)
- Boom position sensors and boom fold control.

And

- Main hydraulic function block which has ..
 - Fan speed sensors (2)
 - Fan speed control (2)
 - Hydraulic pressure (2)
 - Dump

See schematics diagram for more detail.

Note the photo shows the main Fusion hydraulic block (top), boom control manifold (middle) and 8 spray section control valves (below) all installed in an (optional) control box (with the lid removed). Note the orientation of blocks will be different on sprayers without this box.



Photo below is 4 section valves / 2 row sprayer.



Note, in the photo's above and left, the labels (as shown below) have not yet been applied.

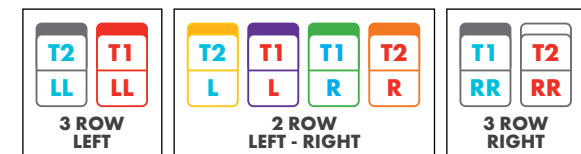

Refer to the separate Fusion Manual for more information on operating the controller & system.

SECTION 4

PRODUCT FEATURES / FAMILIARISATION

WINDCOMP HYDRAULICS

Wind Comp (wind compensation via independent Left/ Right fan speed control) is a new feature made possible by the new Fusion hydraulic system. The fans facing left or right sides can be run independent of each other. This is ideal for combating cross winds or spraying in exposed / challenging conditions. For example, instead of running both sides of the sprayer at 2,200 rpm, with Wind Comp it's possible to increase fan speed against the wind to say 2,500 rpm, and on the downwind side the rpm will drop to around 1,900 rpm.

For more detailed information refer to page 34 and in the Fusion Manual HT-OMFUSION-A.

Note the **laws of physics still apply**, if the maximum speed is 2,500 rpm on all fans, it's not possible to increase one side to 2,800 and leave the other at 2,500.

Note in the photo, the coil **circled** (closest to the main inlet / outlet at position (K), controls the fans that spray to the right side, and the coil below controls the left facing fans. Note in some applications the block is mounted with position (K) to the bottom.

PTO Speed / Hydraulic Requirements

Due to the configuration of the hydraulic control block, the PTO / Pump / Tractor (depending on how oil is being supplied) needs to maintain a minimum output in order to supply both sides of the fan circuits with the same operating rpm. For example, if at PTO = 420 rpm and both LH & RH fans are running at 2,400 rpm, as the PTO speed reduces below the minimum, one side will maintain priority and continue to run at 2,400 rpm and the other side will

drop away and run slower. This feature can be used to determine best PTO speed to economically run the sprayer.

Recommended minimum PTO speed = 420 rpm

Note the actual minimum (at which point the LH and RH fans differ) will change from sprayer to sprayer and is more likely to be lower than 400 rpm.



SECTION 4

PRODUCT FEATURES / FAMILIARISATION

LIQUID SYSTEM OVERVIEW

“Front End” Spray Controls

- A. Pump (AR185 shown)
- B. Hydraulic pump drive, including control manifold
- C. Pressure manifold. This includes the manual master pressure adjustment (knob) and red, manual flick taps to control the suction probe, front & rear agitators and the basket / powder mix

- D. Pressure filter, includes pressure sensor
- E. Pressure Regulator (Servo) & Dump valves.
- F. Flow meter
- G. Suction filter (from tank and into suction manifold of the pump).
- H. Chemical suction probe fitting
- I. Quick fill connection
- J. To Recapture system venturi.

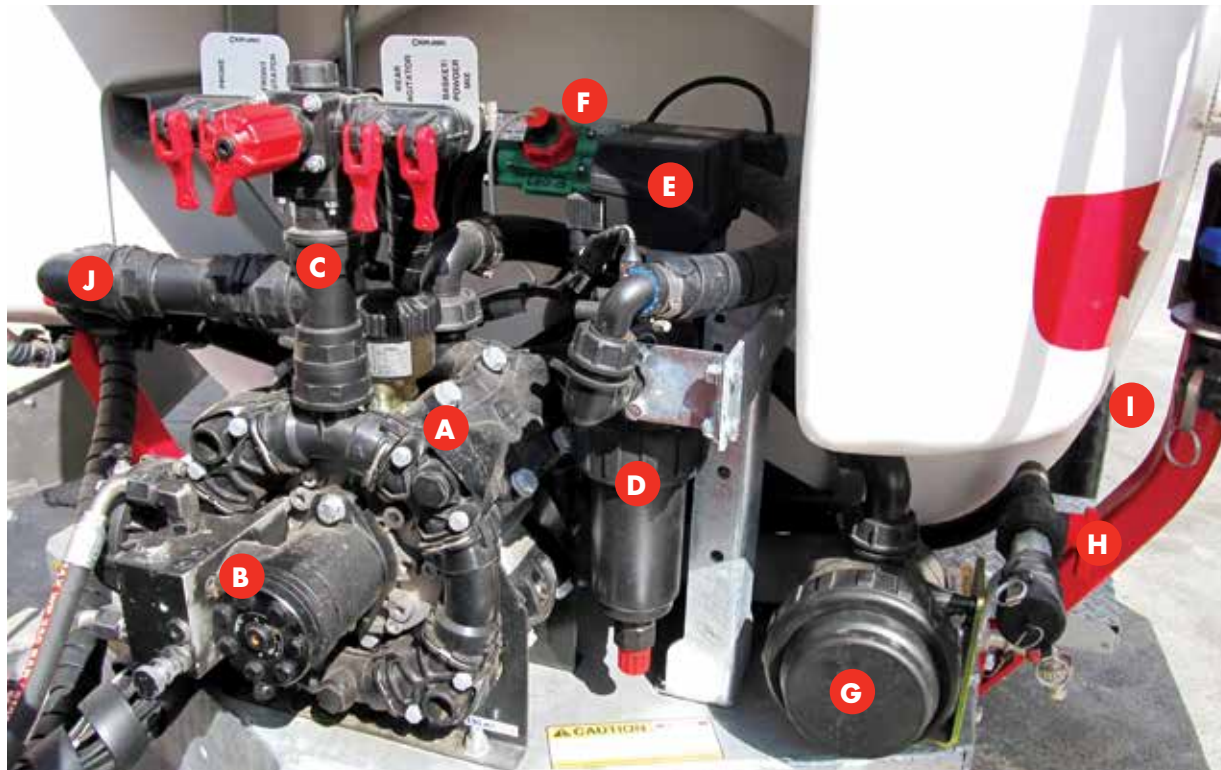

TANKS & SUCTION PLUMBING

Smart Sprayer models feature three tanks, Main (chemical), (fresh) Flushing and (fresh) Handwash for easy operation, cleaning and safety.

All Main tanks are equipped with large lid and basket filter. Plumbed to the filter basket is a Basket / Powder Mix function activated via a tap from the pressure manifold.

All Flushing and Handwash tank lids should be clearly labelled as WATER ONLY. Replacement labels are available under the code XD-127V.



SECTION 4

PRODUCT FEATURES / FAMILIARISATION



All sprayers have a Handwash tap positioned near the main filter (see orange arrow).



Filling the Main tank can be via the basket or separate / remote fill tap and camlock (see blue arrow). On the 2000 model the camlock is on top of the tank. The freshwater Flushing tank on the 4000 model is

incorporated into the main tank and has a separate lid (see green arrow). The handwash tank is at the rear of the tank (green circle). The 4000 Flushing tank can also be remote filled via camlock coupling mounted near the main filter.

The freshwater flushing tank on the 3000 model is separate tank that fits below the main tank, and is filled via a fill tube accessed from inside the handwash tank at the rear of the sprayer (see red arrow).



4000 Flush camlock fill



The 2000 model features separate flushing and handwash tanks integrated into the design of the main tank (circled).



SECTION 4

PRODUCT FEATURES / FAMILIARISATION

Main Tank Drain

All models have a main tank drain positioned near the step on the left hand side (**blue circle**).

Please dispose of any chemical in a safe and environmentally responsible manner.



Tank Selection Valve

The tank selection valve has 3 x positions.

1. **SPRAY** - In this position the pump will draw liquid from the main chemical / product tank.
2. **FLUSH** - In this position the pump will draw freshwater from the auxiliary flush tank.
3. **OFF** - In this position ALL liquid is isolated from the pump. It is only recommended to use this position when pump is not operating i.e. Cleaning out suction filter.



If changing from SPRAY to FLUSH always turn off the pump before making the change.



Main Suction Filter

The main suction filter should be checked and cleaned on a regular basis.

Before opening the filter body, ensure the pump is not running & the Tank Selection Valve is in the OFF position.

To be safe, always assume there is chemical present and take the appropriate safety measures.

Always wear gloves.



Sight Gauges

All main tanks are fitted with both a front (RH side) and side (LH Side) sight gauges. Inside of each clear sight hose is a white float which can be read against the tank markings to display the approximate volume remaining in the tank.

PUMP & PRESSURE PLUMBING

On the pressure output side of the AR pump flow goes to

1. Pressure Manifold where the maximum required pressure is set (central red knob), and 4 flick taps for ...
 - Suction Probe
 - Front Agitator
 - Rear Agitator
 - Basket / Powder Mix
2. If fitted with Mk.1 Recapture system. Refer to p.68 / HT-OMRECAP2-A manual.
3. Servo Dump & Filter manifold which includes
 - a. Dump valve (fast acting – identified by blue band)
 - b. Pressure regulating valve (slow acting (15 seconds) – identified by grey band (visible below 3b))
 - c. Pressure filter (and includes a pressure sensor that couples into the fusion loom)
 - d. To the flow meter (mounted behind the pump) and then to the spray sections valves at the rear of the sprayer.

Refer to Section 5 for more information on how to operate these functions.

SECTION 4

PRODUCT FEATURES / FAMILIARISATION



Photo 1

- 4. Mounted at the rear of the sprayer is a bank of 4 x red tap valves. These activate the venturi suction circuit for the Recapture system (if fitted). Only applicable to Mk. 1 Recapture system.
- 5. Filters for the recapture system (if fitted). Photo 2 shows 2 x suction filters for left inner & left outer Recapture screens. Only applicable to Mk. 1 Recapture system.

- 6. Not fully shown in this photo are the motorised section valves.
- 7. The pressure gauge is mounted either at the front of the Micro Power Pack (photo 4), or on the RH side of the sprayer (photo 3).



Photo 2



Photo 3



Photo 4

TIERED SPRAYING

SECTION 4

PRODUCT FEATURES / FAMILIARISATION

Dual spray rings make it possible to achieve a greater application rate spectrum, more consistent spray pressures, reduces nozzle changes & helps eliminate off target spray drift via 3 Tier spraying.

- Tier 1 / Low rates = Inner rings ON / Outer rings OFF.
- Tier 2 / Medium rates = Inner rings OFF / Outer rings ON.
- Tier 3 / High rates = Inner & Outer rings ON.

All sections are activated via in cab Fusion screen & Joystick control.

Note; Smart Sprayers are using the convention of:



Photo 1

- The smaller / inside spray ring uses the smaller nozzles.
- The larger / outer spray ring uses the bigger nozzles.

Note both rings use the same diameter stainless steel tube, it's the circumference of the ring that's smaller or larger.

Operators can change nozzles to suits their specific requirements – it might be the same nozzle on every spray ring, or it might be a specialist nozzle on either of the spray rings. The choices are never-ending.

Photo 1 shows inlet (top) and outlet (tap at the bottom) of the outer / larger diameter spray ring. To the inside shows the inner spray ring which has similar connections on the opposite side.

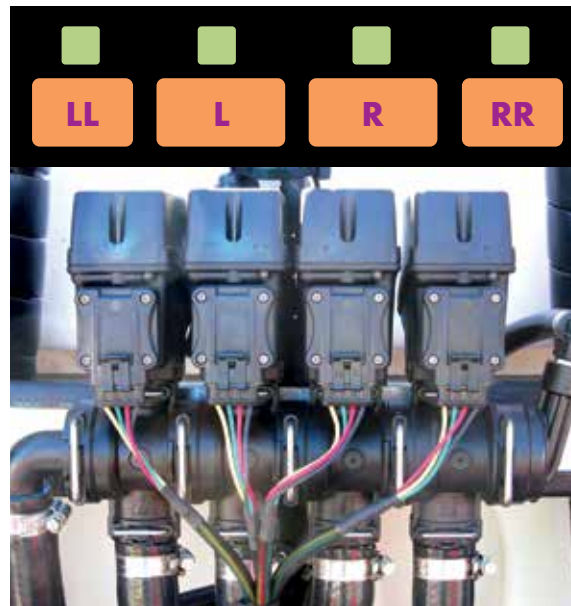

Photo 2

4 Section control (Photo 2)

For a 2 row sprayer:

- LL** Left outer rings
- L** Left inner rings
- R** Right inner rings
- RR** Right outer rings

Using L and R together is Tier 1, all fans are spraying with the inner spray ring.

Using LL and RR together is Tier 2, all fans are spraying with the outer spray ring.

Using LL, L, R & RR together is Tier 3, all fans and all sprayer rings are in operation.

8 Section control (Photo 3)

For a 3-row sprayer.

LL is the left 3rd row fan, and can be operated as Tier 1 only, Tier 2 only or Tier 3 with both T1 & T2 together.

L are the left 1st & 2nd row fans and have the same T1, T2 and T3 options.

R are the right 1st & 2nd row fans and have the same T1, T2 and T3 options.

RR is the right 3rd row fan, and can be operated as T1 only, T2 only or T3 with both T1 & T2 together.

Refer Section 6 and the separate Fusion Manual for more information on operating the controller & spray system.

SECTION 4

PRODUCT FEATURES / FAMILIARISATION



Photo 3



Photo 4

Step

The step, as pictured is in the stored position. For access to the tank lids / quick fill camlock (2000 model) etc, the step must be moved and secured into the extended position.

For the 4000 model, the lids are in a very difficult position to access via the step. For this model, and for access to any other parts of the sprayer not readily accessed from the ground, the operator should use platform steps.



Photo 5

Jockey stand

All QM Smart Sprayers come fitted with 3 x extendable jockey stands. 1 x for the main sprayer chassis & 2 x for the 3 point linkage frame. This ensures safe & stable storage when not connected to the tractor.

Always park the sprayer in a horizontal position and on firm, level ground.

Once the sprayer is connected to the tractor always ensure the stands are removed or folded to the horizontal before moving.



Photo 6



Unhitching the Sprayer from the Tractor

Locate sprayer on level ground and block the wheels so that sprayer does not roll when the sprayer (linkage arms) are disconnected.

Disconnect PTO shaft, hydraulic hoses (if applicable) and Fusion controller loom from the tractor.

SECTION 4

PRODUCT FEATURES / FAMILIARISATION

Attach and adjust all Jockey stands before detaching linkage arms.

Ensure all caps for the electrical (looms) and hydraulic fittings are utilised to help prevent water, dust & dirt ingress.

Photo is for a conventional sprayer without linkage arm connections.

Wheel Speed Sensor

All sprayers are fitted with a Speed Sensor – normally via a proximity sensor installed on the right hand side, rear wheel. The sensor needs to be 5mm from the target, which in this case is the head of the wheel studs on the back of the axle. The sensor is reading cm per pulse.

A GPS speed sensor (Atlas 100) is available as an option.



Photo 2

Pump Speed sensor (photo 2)

The same sensor is used for the spray pump speed. The reading is 1 pulse per revolution.

Flow Meter (photo 3)

All Smart Sprayers are fitted with a flow meter. As a part of the initial factory testing / calibration, a value (pulses per litre) will have been recorded and written on the body of the meter (shown here in blue) or the back of the serial number tag.



Photo 3

SECTION 5

PRE-OPERATION

SAFETY FIRST	28
HOOK UP	28
FIT & SETUP FUSION CONTROLLER TO THE TRACTOR	31
SETUP SPRAY PRESSURE	36
SET-UP THE BOOMS	37
CONFIRMING FAN FUNCTIONALITY	42
PRE-OPERATION CHECKLIST	43

SECTION 5

PRE-OPERATION

After taking delivery, hook up and prepare the sprayer for operation.

SAFETY FIRST

Before progressing further,

- Read and understand the Safety Manual (part no. GP-SAFE-A) supplied with this sprayer.
- Read and understand all manuals to better understand the sprayer.
- Ensure fit for purpose (size, HP, hydraulic capacity, PTO specs.) If in doubt consult the tractor dealer / manual.



HOOK UP

If not using a Micro Power Pack, ensure the tractor to be used has sufficient hydraulic oil flow at the required pressures (max 2,750 psi) to handle the tasks required. If in doubt consult the tractor dealer / manual.

The QM Smart Sprayer has been fully tested before leaving the factory. Some components will require further assembly after shipping from the factory / dealer;

1. Adjust and fit the 2 or 3 point linkage, self-steer drawbar to the tractor
2. Connect the PTO shaft to the tractor and sprayer
3. Fit the hydraulic hoses to the tractor (if applicable)
4. Fit the Fusion controller, joystick and all other relevant connections to the tractor
5. Fit Nupoint (if applicable). See Nupoint instructions.

The QM Smart Sprayer must be connected to a suitable tractor, making sure the drawbar and PTO shaft are fitted according to the supplied instructions.



(1) Drawbar

The drawbar is supplied at it's longest length. If required it can be shortened by 1 hole / 110mm spacing.

(2) Self-Steering Linkage Drawbars

All QM Smart Sprayers are fitted standard with a self-tracking drawbar, either as a part of the Micro Power Pack, or if the Micro Power Pack is not fitted, with the product pump as a part of the drawbar (2 versions). In this way the PTO shaft is maintained in an optimum position for tight turning.



SECTION 5

PRE-OPERATION

Follow the instructions below to connect the linkage self-tracking drawbar to the tractor:

- Ensure the sprayer chassis is horizontal (it may be up to approximately 3 degrees lower at the front).
- Connect the tractor linkage arms to the self-tracking drawbar linkage pins & fit the locking clips.
- (Micro Power Pack) Adjust the top / 3rd link arm to ensure the Micro Power Pack's oil tank is sitting vertically in normal operating height.
- Ensure tractor sway bars are adjusted & locking pins fitted to ensure lateral stability of the tractor linkage arms.



(3) Fit the PTO Shaft



Due to the wide variation in tractors, the sprayer is factory tested with a PTO shaft cut to a length that suits the factory tractors and a new / uncut PTO is supplied with the sprayer. Follow the instructions below to fit the PTO shaft onto the Quantum Mist™ after transit. Note for new installations, the dealer will oversee the fitting of the new shaft. Also refer to the PTO user manual that is supplied with every new PTO shaft.

- Remove the PTO shaft which is usually strapped to the Quantum Mist™ frame.
- Check the PTO shaft has not been damaged in transit.
- Grease the universal joints, telescoping shafts & safety cover bushes.
- Measure and fit the PTO to the Quantum Mist ensuring the locking pin is correctly located.

Cutting the PTO shaft to length requires knowledge of this procedure. If you have not carried out this procedure before, ensure your dealer carries out this important step.

- Before operating the drive shaft, be sure that all safety guards are in place & safety chains are securely fitted (refer to PTO Manual).
- Do not exceed maximum RPM of the pump or gearbox (540 RPM).

SECTION 5

PRE-OPERATION

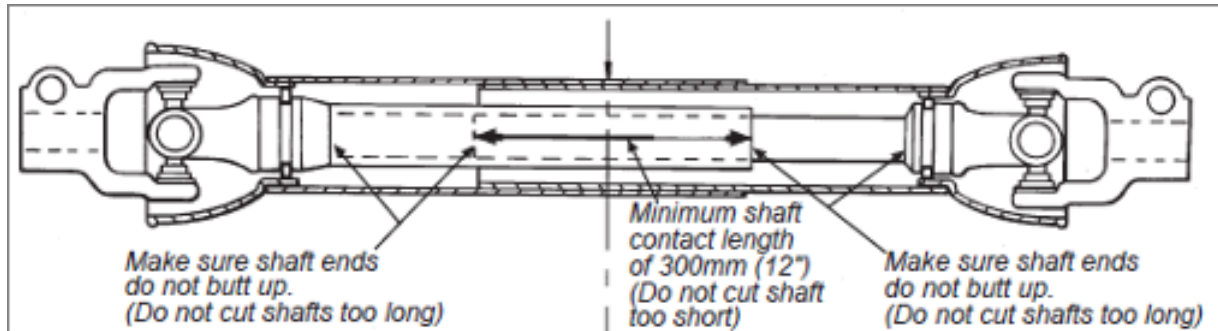

(4) Connect the Hydraulic Hoses to the Tractor

Its important to correctly set up the hydraulic supply from the tractor. Your dealer can carry out this step to ensure no damage or warranty issues will result from incorrect setup. A small charge may be incurred for this procedure.

- For models featuring the Micro Power Pack using twin pumps, there are no hydraulic hoses to connect to the tractor.
- For models with a single pump, Micro Power Pack there is one set of hydraulic hoses (from the spray pump) for connection to the tractor remotes.
- For models without Micro Power Pack, there is one set of hydraulic hoses to connect to the tractor.
 - A set of hydraulic hoses to the main Fusion block, and return to tractor pressure free return port via the oil cooler.
- There are no boom arm connections as these are an integral part of the Fusion control system.

Note all Croplands sprayers use banded, colour coded hydraulic hoses. The pressure line is always 2 bands and the return line is always a single band.

Oil supply (and return) to fans is always **YELLOW**.

Oil supply to the product pump is always **WHITE** (not red as per photo top right).

For models without a Micro Power Pack, oil supply to the fans (via the Fusion control block) requires a 1/2" pressure line connection to tractor remote, and a 3/4" return, DIRECT BACK-TO-TANK.

- Decide on the best supply remote on your tractor to use for oil supply for the fan system.
- Plug the 1/2" oil supply line coupling to your selected remote and ensure the hydraulic line does not foul your PTO or any working parts at the rear of the tractor. Allow sufficient slack in the hydraulic line for turning.
- Hook up the 3/4" return line to the tractor (direct back to tank). As with the pressure line, ensure there is sufficient



slack & no interference with tractor working parts. NEVER connect the return line to the conventional return port.

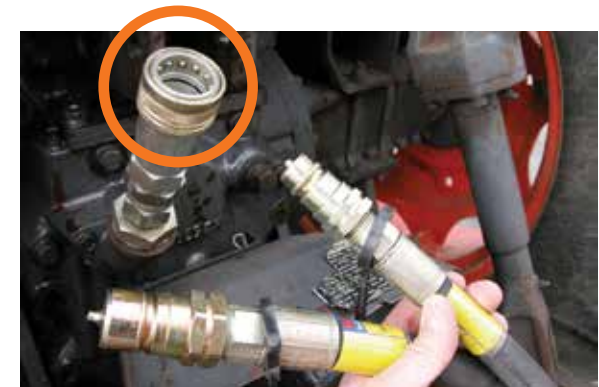

NOTE; Supplied with each non Micro Power Pack unit is a 3/4" fitting for the tractor's return to tank port, as shown and circled in **orange** (above). This is to ensure there is

SECTION 5

PRE-OPERATION

no back-pressure on the oil return from the Quantum Mist sprayer. Ask your dealer to fit the 3/4" female return coupler direct back-to-tank.

NEVER connect the (fan) return line to the conventional return port, **MUST** always be connected to the "direct back to tank" port. **ALWAYS** double check that the return line is properly connected before engaging hydraulics. Failure to comply with this instruction can lead to catastrophic hydraulic failure.



For models using a hydraulically driven spray pump, connect the 1/2" pressure and return line hoses to the same set of tractor remote couplings. Best practice is to adjust the tractor oil flow to give the pump speed required (450-540 rpm) is recommended.

Pump speed is displayed on the Fusion Controller. DO NOT exceed 540 rpm.

NOTE

The hydraulic system cannot be operated until the Fusion Controller is operational

FIT & SETUP FUSION CONTROLLER TO THE TRACTOR

The Fusion electric controller has been fitted and adjusted at the factory but has been disconnected and packed for transit.

Also supplied are the Fusion operators manual, joystick,



power / controller looms and mounting hardware.

Also refer to Section 3, page 4 of this manual for an overview of the Fusion control system.

Fit the controller / display console into the tractor cab in a convenient & safe location for the operator.

Repeat the same for the joystick.

Connect the controller couplings to the supplied loom. The loom goes from battery – joystick – display screen – break at back of tractor where it connects to the loom already installed on the sprayer.

As the section valves can draw a small current even with the controller turned off, **disconnecting at the back of the tractor is a good way to make sure everything is off.**

For most operators the controller will be wired to be "live" with the tractor ignition.

Confirming Fusion Functions

The Fusion control system is very intuitive, and most primary systems can be controlled via the Joystick. Now is a good time to add some freshwater to the main tank, power up the tractor (at low rpm) and confirm the hook up is correct / learn the control functions. Also note the checklist at the end of this chapter on page 43.

Power up the tractor and engage the hydraulic system (via remotes or PTO driven Micro Power Pack) - no need for full power at this stage – if using the PTO, set to 300rpm.

SECTION 5

PRE-OPERATION

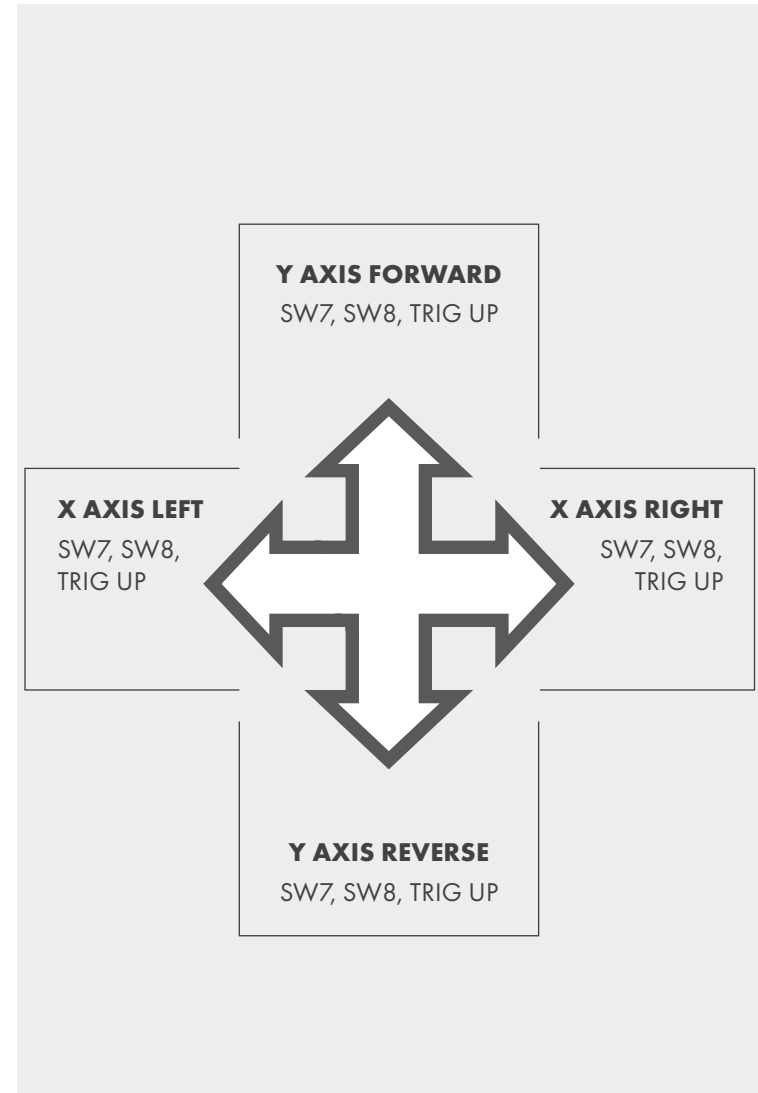
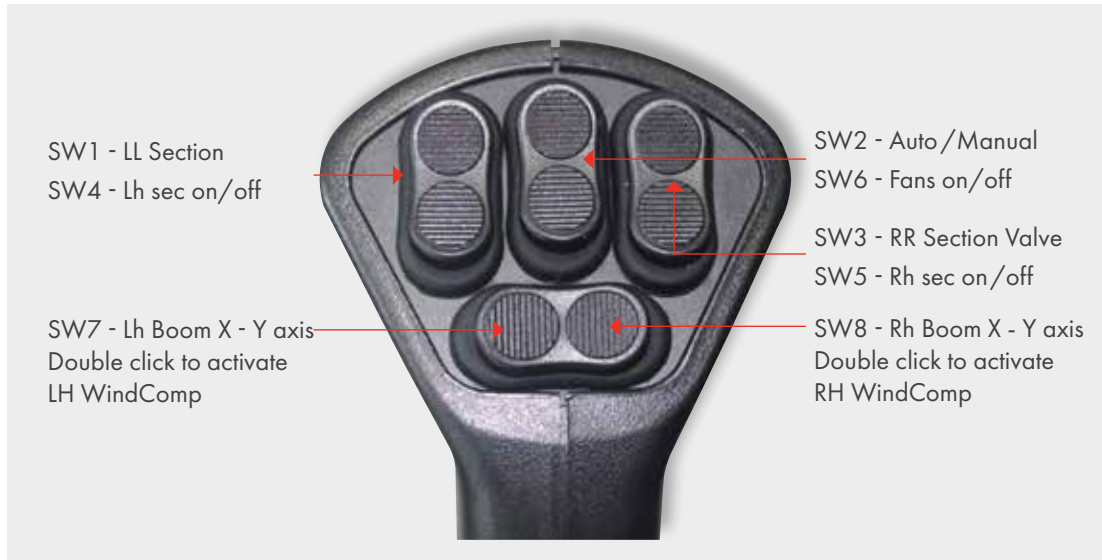

SECTION 5

PRE-OPERATION



Left Boom Arm

Press and hold SW7 on the joy stick.
By moving the joystick to the X Axis Left position, the left boom arm will fold in.
By moving the joystick to the X Axis Right position the left boom arm will fold out.



Right Boom Arm

Press and hold SW8 on the joy stick.
By moving the joystick to the X Axis Left position the right boom arm will fold in.
By moving the joystick to the X Axis Right position the right boom arm will fold out.



Left Terracing

Press and hold SW7 on the joy stick. By moving the joystick to the Y Axis Forward position the left boom arm will lift. By moving the joystick to the Y Axis Reverse position, the left boom arm will go down.



Right Terracing

Press and hold SW8 on the joy stick. By moving the joystick to the Y Axis Forward position the right boom arm will lift. By moving the joystick to the Y Axis Reverse position, the right boom arm will go down.

SECTION 5

PRE-OPERATION

Fusion Fan Operation



Activating Fans

Enter the "Hydraulic" tab on the right side of the main screen. Set "Master" to 100 and "Wind Comp" to 0. Activate the fans by pressing SW6 on the joystick. The left and right fan rpms will appear under the Master and Wind Comp sliders. While the PTO speed is low one of the fan rpms will read around 2500 and the other will be lower. Gradually increase the PTO speed and the lower rpm reading will even up, at this point you now know the lowest PTO rpm you can run this system at to achieve 2500 fan rpm. It is recommended though that you run at least 500 PTO rpm to ensure sufficient hydraulic flow. See page 42 re confirming fan functionality.

Changing Fan Speeds

By moving the "Master" slider up or down both fan rpms will increase or decrease and will stay even when the wind comp is set to 0.



WindComp (see more re WindComp on page 19)

On the home spray screen you will notice there is an arrow pointing left or right. This arrow indicates which facing fans are blowing into the wind and will have a higher fan rpm if wind comp is activated. This arrow is changed by double tapping SW7 or SW8. For example, if the arrow is pointing left you will double tap SW8 to change to the right and then double tap SW7 to change back to the left.

Enter the "Hydraulic" tab on the home screen. With the Master slider set to 100, increase the Wind Comp slider. As you increase the Wind Comp slider you will notice the fan rpm going with the wind starts to drop off. You can then double tap the appropriate SW7 or SW8 and these fan rpms will flip.



If the Master is set to anything below 100 when the Wind Comp slider is increased the

sprayer fans blowing into the wind will increase and the sprayer fans blowing with the wind will decrease.

To deactivate Wind Comp set the slider to 0. The arrow indicating which fans are going into the wind will still be present on the home screen but no change in fan speed will occur if SW7 or SW8 are double tapped.

To turn off the fans press SW6



Spraying

Selecting Tiers – From the "Spray" screen press on "Calibration". The bottom right section of the screen will have a box displaying which tier is currently selected. This can be pressed to select Tier 1, Tier 2 or Tier 3. On the spray screen there will be T1, T2 or T3 shown above the tank to indicate which tier is selected.

SECTION 5

PRE-OPERATION

- Tier 1 / Low rates = Inner rings ON / Outer rings OFF.
- Tier 2 / Medium rates = Inner rings OFF / Outer rings ON.
- Tier 3 / High rates = Inner & Outer rings ON.

Setting target rate

From the "Spray" screen press on "Calibration". Press the up/down arrows until the desired rate is shown.

Setting row width

From the "Spray" screen press on "Calibration". Press the increase/decrease buttons either side of the row width to adjust.

Master/Dump Valve Operation

On the "Spray" screen there is a tap labelled "Master Valve". When this button has a Yellow border and writing the dump valve is activated and will operate via the joystick. When the button is Yellow with White writing the dump valve is locked in the spray position and will not change via the joystick.

Activating Sections

On the "Spray" screen there will be a picture of either a single row, 2-row or 3-row sprayer unit depending on your sprayer model. Each of these rows will have an oval shape next to them indicating the sections. If the oval is Grey then this section cannot be activated to spray via the joystick. To activate the sections press on the Grey ovals and they will turn Blue, these sections can now be activated to spray via the joystick. There is a bar below each section that is Grey when the sections are turned off and goes Green when the sections have been turned on via the joystick.

Joystick



Section LL is turned on/off with SW 1



Section RR is turned on/off with SW3



Section L is turned on/off with SW4



Section R is turned on/off with SW5

All activated sections can be turned on/off at once with the "TRIG DOWN" switch and this will also work the dump valve if activated.

Manual/Auto mode

On the "Spray" screen there is a tab to select manual or automatic rate control modes. To change between the modes you press this button and the word in Red is what mode is selected.

When manual mode is selected an up and down button will appear on the spray screen. These can be used to adjust the spray pressure manually.

When auto mode is selected the controller will lock onto the target rate shown on the screen. The target rate can be changed in the "Calibration" screen.

SECTION 5

PRE-OPERATION

SET-UP SPRAY PRESSURE

Croplands recommends setting the maximum system pressure to be 10% above the chosen spray pressure which is normally an extra 0.5 - 0.8 bar.

With the maximum pressure set, the finer adjustments are controlled by the Fusion (auto rate) controller.

The system pressure is set via the **central red knob** of the manual Pressure Regulator Valve (see photo 1).



Photo 1

The regulator will need to be adjusted from time to time – as rates between Tier 1, Tier 2 and Tier 3 can require a Manual Pressure adjustment.

WARNING; To set and forget at high pressure will put undue stress / wear and tear on the system. Maximum recommended pressure is 12 bar but 5 to 8 bar is recommended.



Photo 2

To set for the first time:

- Ensure that the nozzles fitted on the sprayer are applicable to your desired rate & recommended operating pressure.
- Wind the pressure control knob anticlockwise to ensure the sprayer starts up with limited pressure
- Ensure the tank selection valve is in the "SPRAY" position

- Start the tractor (assuming the Fusion controller is fitted and engaged, ready to spray)
- Start the pump by engaging the Tractor remote (Micro Power Pack version) or PTO. Set to operate at your required rpm, usually between 450 and 540 rpm
- Engage both Front and rear Agitators
- Note: The fans do not have to be engaged during this process
- With the Fusion controller in manual mode, select the appropriate Tier for the application rate and turn on all the sections. Once the unit is spraying press and hold the "UP" arrow on the screen for 10 seconds to ensure the servo valve is in the closed / pressurised position.
- Slowly wind the pressure control knob clockwise (if needing to increase pressure) until your required operating pressure is reached, and add a further 10% surplus pressure.
- Example - If the application rate is 500 L/ha and with your row width/nozzles & spraying speed the rate is achieved at 7 bar, you would set the maximum system pressure to 7.7 bar

Once done, leave the manifold setting (red knob) "as is" until a change of operating pressure is required.

SECTION 5

PRE-OPERATION



Main Boom Arm Components

- A. Main boom arm slide. In this example 3 holes are exposed, hence 2.95 (nominal 3.0m) row spacing.
- B. Push - Pull rod, connecting at each end via tie rod ends. Minor length adjustment via the rod ends. See note below re the alignment of the bend in the rod.
- C. The push-pull rod main length adjustment is via a series of holes that match the main boom arm.
- D. The push-pull rod is connected to the sprayer via a tie rod end.
- E. The push-pull rod is connected to the fan frame / swivelling head via a tie rod end.
- F. The breakaway / swivel head which connects boom to the fan frame.

SECTION 5

PRE-OPERATION

SET-UP THE BOOMS

It is recommended that the setting up of the Quantum Mist Smart Sprayer boom and fan positions should be done in conjunction with a qualified specialist. (Croplands dealer, Croplands Representative, Agronomist or Spray manager). The optimum set-up will vary significantly from vineyard to vineyard & stage of canopy growth.

- Where possible run the over row fan frames down the middle of the row – this makes for foolproof setup / width decisions. For ease of use, take all measurements from the centre of the fan frame.
- A parallelogram system via a push-pull rod ensures the fans are positioned parallel to the canopy regardless of the boom arm position from fully open through to neatly parked, see example in Fig 2.

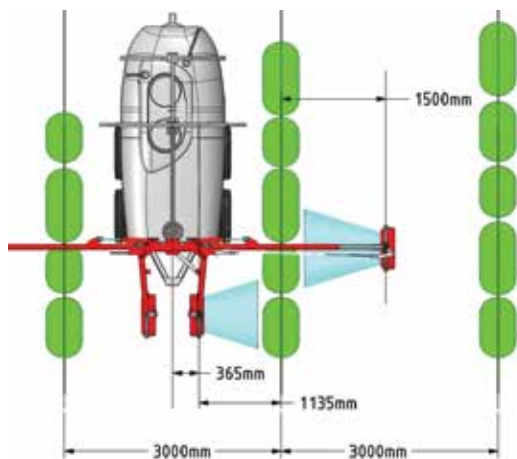

Figure 2.

Main Boom Arm Row Width Method

There are 2 ways of adjusting the main boom arm for row width.

1. The main boom arms can be physically adjustable for length (see next page), via a series of adjustment holes as is the corresponding push-pull rod. Refer example in Fig. 2 showing a 2-row sprayer with the over-row boom set in the middle of a 3 metre row. Where possible set the boom arms to the maximum width rows likely to be sprayed, for example if the block is a mix of 2.7 and 3.0m rows, set the booms to suit 3.0m.
2. Using the Fusion control system, the boom arms can be moved to a partially closed position, hence changing the operating width of the sprayer. Due to the pull-push rod system, the fans maintain a parallel position to the target.

Fig. 1 is an example of the same sprayer in Fig 2 (with a boom set to 3.0) operating in a 2.7m row.

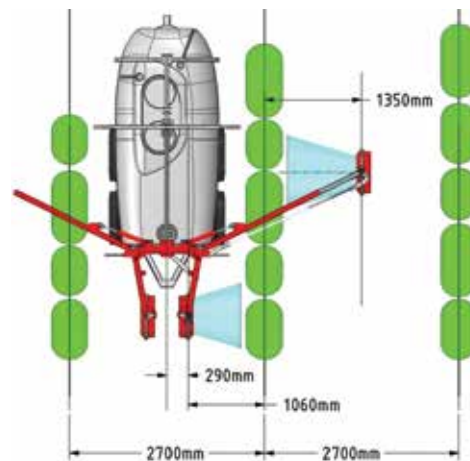

Figure 1.

Refer page 43 for more detail on adjusting the fans behind the sprayer.

Main Boom Arm Adjustment

The main boom arms have an outer slide section to enable adjustment for different row widths.

Nominally the standard boom can accommodate row widths from 2.5 to 3.4 metres, visible via 0 to 6 holes exposed on the slide – see image (next page), **yellow circle**. The Wide Tower option (see page 16), adds an extra 350mm each side.

6 holes exposed	= 3.4m row width (3.75m with wide tower)
5 holes exposed	= 3.25 row width (3.6m with wide tower)
4 holes exposed	= 3.1 m row width (3.45m with wide tower)
3 holes exposed	= 2.95m row width (3.3m with wide tower)
2 holes exposed	= 2.8m row width (3.15m with wide tower)
1 hole exposed	= 2.65m row width (3.0m with wide tower)
0 holes exposed =	= 2.5m row width (2.85m with wide tower)

SECTION 5

PRE-OPERATION

Push - Pull Rod Adjustment

The push – pull rod has 3 points of length adjustment.

- At position (C) is an adjustment to match the boom arm's length. If the adjustable boom arm has 3 holes visible (**large yellow circle**), then the tie rod needs 3 holes visible (**smaller orange circle**). At maximum length, 6 holes are exposed.

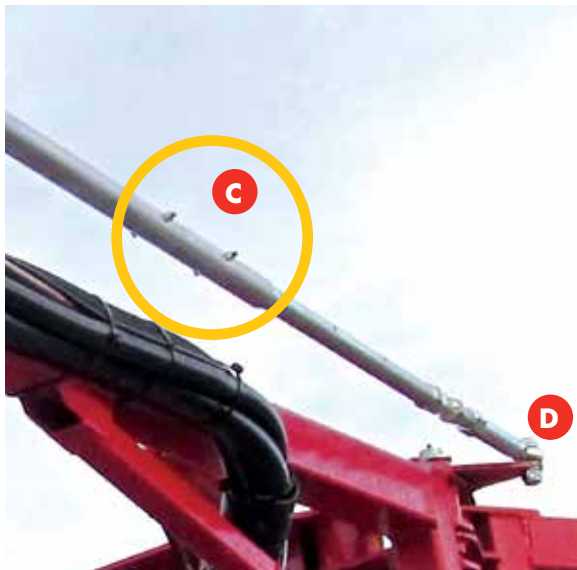

Photo 1

- Fine adjustment, primarily to adjust the alignment of the fans, is via the tie rod ends at each end (D) and (E). ALWAYS check that the tie rod ends are free to rotate;

The push - pull rod has a bend in order to clear the fan frame hanger in the parked position - see photo 2 (open) and photo 3 (parked).

The alignment of the bend is not critical on a 2-row sprayer (as can be seen in the photo on page 37, position B). The preferred option is with the bend pointing towards the direction of travel, as in photo 2.

After making adjustments, **ALWAYS double check** for free movement of the Push-pull rod and connections throughout the full travel range. Check that the tie rod ends have free movement.

3-Row Boom

3-row sprayers use the "Twin Hanger" system (see G below) which allows 2 sets of fans to be "hung" onto each main boom arm. One set of fans face towards the tank (2nd row), and the other set of fans face towards the "3rd" row.

Each set of fan frames is individually adjustable for spray direction – normally square to the target (see H & G below).

Photo 2 shows the Hanger system with boom open and Photo 3, boom closed.

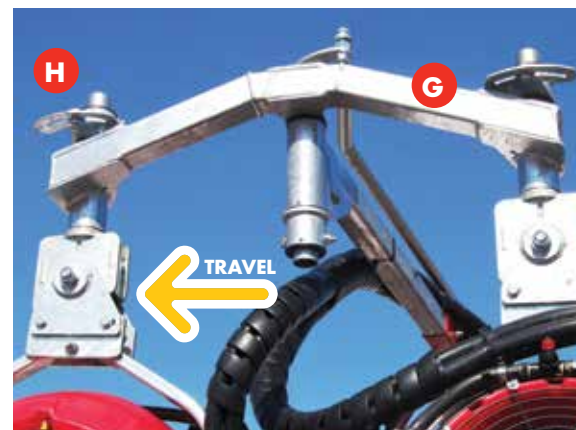

Photo 2



Photo 3

The Hanger system is also used for Recapture screens, as shown (see J above).

Fig 3 shows the preferred configuration of a 3-row sprayer for spraying in 3.0 m rows.

This is the "Standard" build for a 3-row sprayer.

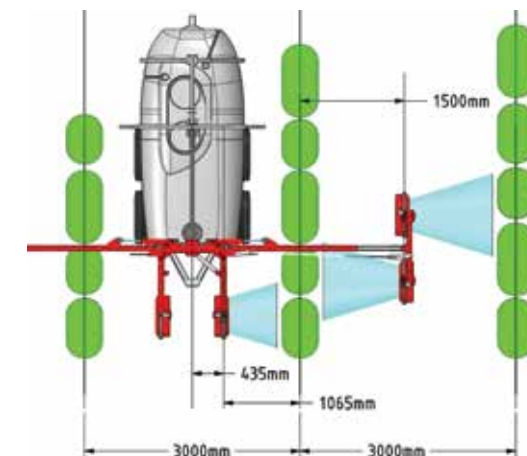

Figure 3.

SECTION 5

PRE-OPERATION

Fig 4 shows an optional configuration required for the 2 & 3-row fans to be spraying closer to the crop (offset Spray fans). Note the spray configuration of the fans is different to that show in Fig 3.

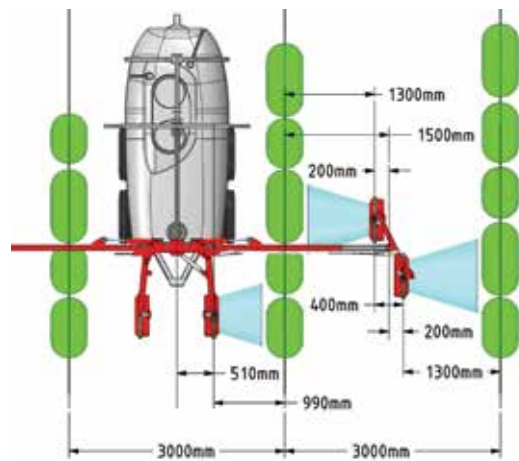

Figure 4.

3-Row tie rod

At the bottom of each set of 3-row fan frames is an adjustable tie rod (see photo 1). The purpose of this rod is to keep the 2 fan frames apart when the breakaway is active.

In some cases, where the hanger is heavily angled to offset the fans closer to the canopy, it might be necessary to swap one of the tie rod ends to the opposite side of the trailing frame.



1st Row / Rear Booms

The rear / inner boom arms are manually adjusted for row width. There are 2 adjustment points - the first at position (L) is a series of notches – or for half notches the opposite end (M) has 2 holes to choose from.

After setting the inner row width adjustment at (L) & (M) the fan frame spray angle may need to be re-adjusted at (K) for optimum fan orientation to the canopy.

See Fig 1 to Fig 4 (pages 38, 39 & 40) to understand the variations created by selecting different notches in the boom positioning bar, on a standard boom and tower.



Photo 1

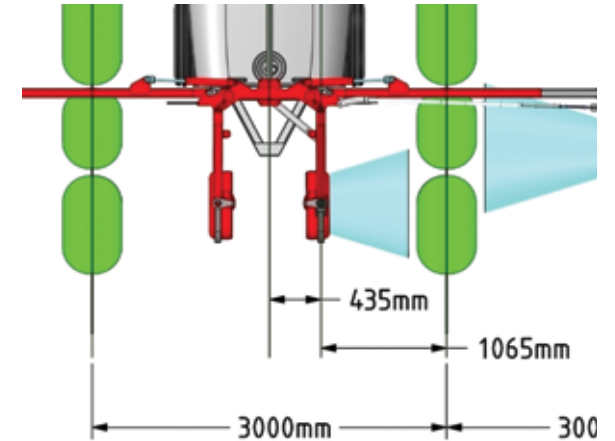

Figure 1	= Notch 1 580mm between fan frames
Figure 2	= Notch 2 730mm between fan frames
Figure 3	= Notch 3 870mm between fan frames
Figure 4	= Notch 4 1020mm between fan frames
	= Notch 5 1160mm between fan frames
	= Notch 6 1330mm between fan frames

Note these numbers are rounded. Even more options exist by using the alternative hole at the tower mounting position (M).

SECTION 5

PRE-OPERATION

Positioning of the rear boom positions can impact fan performance ...

- Less than 800mm between fan frames may see some slight loss of overall effectiveness.
- Fans too close to the canopy may leave gaps in the coverage (unlikely with 3 fans per frame).
- Notch 3 is considered the ideal starting point as it's well protected behind the sprayer and generally an ideal distance to the canopy.

SET-UP THE SPRAY FANS

For those setting up 3 fans per frame sprayer – congratulations, it's hard to miss the target, and far less critical on setup than 2 fans per frame.

The following fan positioning adjustments are available in order to maximise spray efficacy.



Fan Clamp - Reversed

Moving fans up and down within the frame to best position spray in relation to the canopy. Adjustment via loosening the fan clamps at position A.

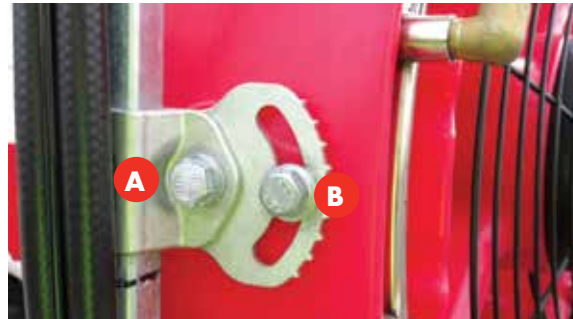

Angling fans up (common with bottom fans) straight ahead or down (common with top fans). Adjustment via loosening the fan clamps at position B.

Rotating the fan frame to point the fans forwards (direction of travel) or to point backwards. This adjustment is made at position K on page 40.

The fan (fan frame) distance from the canopy is adjustable via boom positioning.

A repeatable recipe for spraying can be built by combining the boom and fan position settings with the spray data.

Fan Clamp

Note the stainless steel fan mounting clamps have “teeth” set at every 10 degrees, and the gap between is 5 degrees. Total movement of 45 degrees up and down, either side of centre (larger “tooth”).

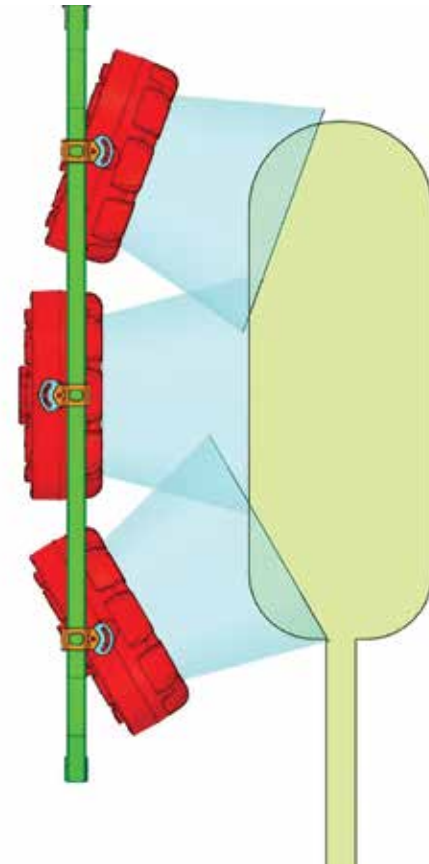

Both M12 bolts on both sides need to be loosened to enable adjustment of the fan position or angle. The cowling inserts are brass.

The “normal” fan position is with a minor portion of the fan sitting forward of the frame (hence better protected), as shown in the middle fan.

SECTION 5

PRE-OPERATION

However, the fan frame clamps can be installed “backwards” which will offset the fan 130mm closer to the canopy. This is an option for top and / or bottom fans (as shown here) which are usually angled downwards or upwards.

If this change is made – double check the clearances with the boom in the parked position.

Examples of Fan Configurations

Fan set up is unique to each vineyard, canopy and spray task at hand. The following is for EXAMPLE ONLY.

Setting up the Quantum Mist Smart Sprayer boom and fan positions should be done in conjunction with an agronomist / spray manager / someone skilled in the art of spraying.

Much of the QM Smart Sprayer prototype development was done in the Barossa Valley in sprawl canopy Shiraz and similar. Water sensitive papers are a great way to check and are available from Croplands.

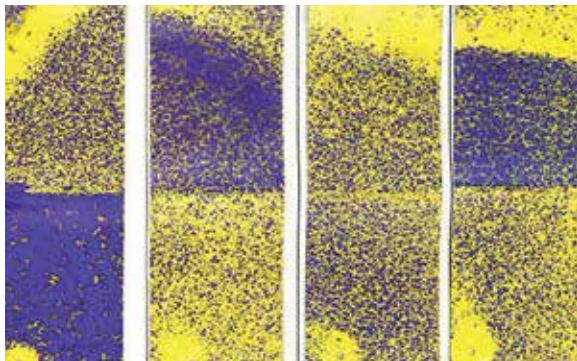

The best 3 fan (per frame) setup was

- Fan frame square to the target
- Bottom fan angled upwards by 25 degrees
- Middle fan angled upwards by 10 degrees
- Top fan angled downwards by 20 degrees
- Fan speeds between 2100 and 2300 rpm were more than enough to get the job done.

The best 2 fan (per frame) setup was

- Fan Frame square to the target
- Fans approx. 1100mm apart (measured at the clamp centrelines)
- Both fans set to 20 degrees (bottom up 20, top down 20)
- Fan speeds were around 2500 ~ 2600 rpm

Back to back testing against QM-500 sprayers has been more than favourable.

The 3-fan frames x QM-420 being the most outstanding performer in all conditions tested.

NOTE: the above examples are for information / training purposes only – and will vary depending upon local conditions and spray requirements.

CONFIRMING FAN FUNCTIONALITY

The Fusion system features an electronic 4 ~ 6 second “soft start/soft stop” function to protect the fans against excessive loads on start-up and shut down.

From the factory, the fan system will have been tested to at least 2,500 rpm. Some models will be capable of operating closer to 2,800 rpm.

When confirming fan functionality / rpm performance, be aware that oil temperature (especially cold oil) will have an impact on peak performance.

For an initial start-up, use low tractor rpm (for tractor supplied hydraulics) or low PTO speed (for Micro Power Pack) and gradually increase speed as required - see pages 31 ~ 34.

Full operating rpm will not be available until the hydraulic oil is at operating temperature / until the thermostat controlled oil cooler fan has switched in (at around 50 degrees C). This is normally around 5 minutes but can be 30 minutes or more on cold mornings.

SECTION 5

PRE-OPERATION

PRE-OPERATION CHECKLIST

Before operating the sprayer, please check the following items.

All chemical & safety guides have been read, understood and acted upon.
The operator is familiar with all control functions.
Secure sprayer connected to the tractor – jockey wheels stowed away.
Wheel nuts (M18) checked for correct torque.
<div data-bbox="266 775 736 938" data-label="Image"> </div> <div data-bbox="266 946 736 1257" data-label="Image"> </div>
Check tyre pressures and even from side to side. All tyres will have maximum rating listed on the tyre sidewall. From the factory sprayers are delivered with 40 ~ 50 psi in each tyre (will vary from model to model).

PTO connected, and safety guards correctly installed.
Fusion controller correctly connected to power, joystick, screen and sprayer.
Confirm correct oil level in the Micro Power Pack (or tractor if no MPP).
<div data-bbox="904 750 1382 1038" data-label="Image"> </div>
Check pump(s) oil levels.
Confirm the spray pump operation.
Manual pressure regulator is set.
Check for wear and tear on all chemical and hydraulic hoses and wiring looms.

Ensure that suction, pressure and recapture filters are clean. Be safety aware as some spillage is likely.
<div data-bbox="1545 549 2056 900" data-label="Image"> </div>
Check that nothing is loose or damaged.
Check the alignment of all booms, fans and (if fitted) Recapture screens.
Check that all tanks and spray lines are clean and empty, and the drain tap is closed.
<div data-bbox="1545 1169 1939 1425" data-label="Image"> </div>

SECTION 6

SPRAY OPERATIONS

EMERGENCY ACTION PLAN

Never operate the sprayer without an action plan in place for when things go wrong ...

“Take 5” to evaluate the risks

Actions for most foreseeable machine issues such as breakages start with ...

“Drop the speed”

“Dump the pressure”

then evaluate further.

SAFETY FIRST	45
FILTERS	45
FILTERS	45
FILLING THE SPRAYER	46
SETTING SPRAYER PRESSURE	46
AGITATION	47
MIXING BASKET	47
CHEMICAL PROBE	48
CALCULATE WATER & CHEMICAL QUANTITIES	49
PROCEED TO SPRAY	50
FLUSHING	51
TANK AND EQUIPMENT CLEANING	52

SECTION 6

SPRAY OPERATIONS

The pre-operation and familiarisation tasks must be completed before commencing spray-operations.

Also refer to the familiarisation section, pages 11 - 26.

SAFETY FIRST

Before progressing further,

- Read and understand the Safety Manual (part no. GP-SAFE-A) supplied with this sprayer.
- Read and understand this manual to better understand the sprayer.

FILTERS

Filters will ensure that no solids enter the system to block or damage pump or spray nozzles.

- Always ensure the basket filter is in place if filling via the main tank lid.
- All filters should be cleaned regularly, after each spraying period and for any period where the sprayer will remain idle. Wear protective clothing.
- If the filter screen is damaged, replace with a new screen.

Cleaning the suction filter

The suction filter should be cleaned regularly or after each spray tank has been emptied.

To clean the filter:

- **Always wear gloves**
- Completely stop all sprayer functions.



- Place the Tank Selection valve in the closed position to shut OFF liquid from the main tank.
- Some spillage is likely, therefore perform this operation in an appropriate place, and with safety clothing.

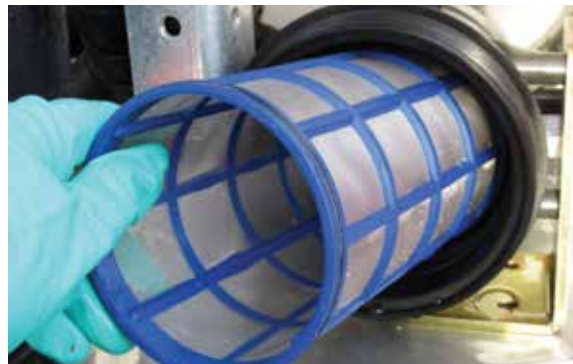

- Remove the outer filter screw and bowl, and then remove the filter and thoroughly clean it.
- Check the condition of O-Ring before reassembling the filter.
- Remember to turn the ball valve back to SPRAY or FLUSH when finished.

Cleaning the Pressure Filter

The pressure line filter should be cleaned regularly or after each spray tank has been emptied.

To clean the pressure line filter:

- **Always wear gloves**
- Completely stop all sprayer functions.
- Some spillage is possible, therefore perform this operation in an appropriate place, and with safety clothing.
- Open the valve at the bottom of the filter to ensure all pressure is removed from the filter.



SECTION 6

SPRAY OPERATIONS

- Remove the outer filter bowl, and then remove the filter and thoroughly clean it before re-assembly.



- Make sure the valve, at the bottom of the filter, is closed before operation.

FILLING THE SPRAYER

Use clean freshwater, free of suspended organic matter or clay as some chemicals are de-activated when they contact these materials. Ensure sufficient water quantity to allow correct product blending.

Main Tank

When filling the main tank (freshwater only), open the spray tank lid and fill the tank with the basket filter in place. Clean the basket and replace the lid after filling.

Or ...

Fill via the separate camlock quick fill (freshwater or chemical premix). Connect to the water source before opening the ball valve. Shown here in the off position.



Flushing Tank



Use FRESHWATER ONLY (preferably rainwater) in the flushing tank. Unscrew the lid and fill before spraying. Replace the lid after filling. 2000L model shown (next page).

Hand-wash Tank

Fill the hand-wash tank with FRESHWATER ONLY from a source remote to any chemical source. Replace the lid after filling.

Always maintain the correct caution label at the fill point.

For more information on the tank positions across the range see Section 4, pages 21-22

SETTING SPRAYER PRESSURE

The regulator will need to be adjusted from time to time – early season with low spray application rates versus peak season with higher spray rates will require this regulator to be adjusted (see Set-up on page 41).

WARNING; To set and forget at a high pressure will put undue stress / wear and tear on the system. Maximum pressure is 12 bar but 5-8 bar is recommended.

SECTION 6

SPRAY OPERATIONS



AGITATION

When chemical is added to the tank, the pump and agitator(s) must be operating at all times to ensure chemical does not settle in the tank.

- Start the tractor.
- Start the pump by engaging the Tractor remote (Micro Power Pack version) or PTO. Set to operate at your required rpm, usually between 450 and 540 rpm
- Red flick taps need to be in the UP position. Shown here are both are in the off position.



MIXING BASKET

A separate chemical mixing basket is provided in the main tank to allow the operator to add and mix chemicals to the main tank while it is filling.



- Check to see that tank agitators are working via the tank lid To do this use the step provided (2000L model) or use a suitable platform to access the lid. Refer to page 25.
- If agitation causes too much foaming in the tank, turn off one or both agitators.
- If chemical settles, through pump break down or other reasons, start up the sprayer after the fault has been rectified, then let the mixture in the tank agitate for a length of time to ensure thorough mixing of the chemical.

SECTION 6

SPRAY OPERATIONS

To operate the mixing basket:

- Fill the main tank with the appropriate amount of water
- **Always wear gloves**
- Measure the chemical required for the tank mix and place the chemical (liquid, powder or granules) into the mixing basket & close the mixer lid. This process is best done in several smaller batches of chemical.



- Check the Tank Selection valve (located at the front of the sprayer) is open to SPRAY.



- Start the Tractor
- Make sure the Fusion controller is NOT in Spray mode (MASTER is yellow, no green section lights)



- Start the pump by engaging the Tractor remote (Micro Power Pack version) or PTO. Set to operate at your required rpm, usually between 450 and 540 rpm

- Open (flick UP) both AGITATOR valves.
- Open (flick up) the mixing basket valve (**make sure the lid is closed**)
- Allow sufficient time for the chemical to mix into the tank. The actual time will vary depending upon the product used
- **Close the mixing basket valve** before next opening the lid.



CAUTION

Always follow chemical label safety instructions. When handling chemicals always wear protective clothing ie. gloves, face mask, spray suit. Should chemical come in contact with skin immediately rinse off with water.

CHEMICAL SUCTION PROBE

An alternative to the mixing basket (which is best used for powders and granules) is the chemical probe. Designed to suck liquid chemical, via a venturi system, straight from containers and into the main tank.

- **Always wear gloves**
- Connect the probe to the sprayer as pictured making sure the ball valve (as circled) is in the off position
- Prepare the chemical source. **Be especially vigilant of chemical safety.**

SECTION 6

SPRAY OPERATIONS

- Start the Tractor
- Make sure the Fusion controller is NOT in Spray mode (MASTER is yellow, no green section lights)
- Start the pump by engaging the Tractor remote (Micro Power Pack version) or PTO. Set to operate at your required rpm, usually between 450 and 540 rpm. Higher rpm will give better suction.
- Open (flick UP) the PROBE valve
- Place / hold the probe's tube into the chemical source (usually a drum of chemical).
- To suck chemical from the drum to tank, turn on the probe connection ball valve (circled in **yellow**, shown in the off position). Use the ball valve to control the suction. Turn to off when finished.



- Flush with / suck from a clean water source when finished.



CALCULATE WATER & CHEMICAL QUANTITIES

Before spraying it is necessary to calculate the exact quantities of water and chemical needed to spray the required area of orchard or vines.

For **CHEMICAL required** expressed in litres or kg per hectare (land area), use the following formula:

$$\text{Chemicals required (Litres)} = \frac{\text{Tank Volume (L)} \times \text{Recommended Chemical Rate (L/ha)}}{\text{Spray Application Rate (L/ha)}}$$

eg. $\frac{1500 \times 5}{400} = 18.75 \text{ litres}$

For **tank VOLUME OF MIXTURE required** to spray the selected area, use the following formula:

$$\text{Tank Volume Required (Litres)} = \text{Area (ha)} \times \text{Spray Application Rate (L/ha)}$$

eg. $3.75 \times 400 = 1500 \text{ litres}$



SECTION 6

SPRAY OPERATIONS

For **AREA COVERED** (ha),

$$= \frac{\text{Tank Volume (litres)} + \text{Spray Application Rate (l/ha)}}{100}$$

eg. $\frac{1500 \div 400}{100} = 3.75 \text{ Ha}$

For **CHEMICAL RATES** expressed in Litres or kg per 100 litres of water (water volume), use the following formula:

$$\text{Chemicals Required (Litres)} = \frac{\text{Tank Volume (Litres)} \times \text{Recommended Chemical Rate (L/100 litres)}}{100}$$

eg. $\frac{1500 \times 3 \div 100}{100} = 45 \text{ litres}$

NOTE

Important: Be sure to mix only enough spray mixture to cover the area required. Avoid wastage and problems of needless chemical disposal.

PROCEED TO SPRAY



WARNING

SAFETY INSTRUCTIONS

1. Read your operators manual thoroughly before operating the sprayer.
2. Inspect hoses, connections and nozzles daily.
3. Clean filters regularly.
4. Always follow correct maintenance schedules outlined in operator's manuals.
5. Always read chemical manufacturers labels before use.
6. Always observe all warnings on chemical products.
7. Regularly check all nuts and bolts are tight.
8. Always wear rubber gloves and wash sprayer down before doing any repair or maintenance work.
9. Do not ride on sprayer when moving.
10. Keep clear of moving parts when sprayer is operating.
11. Always keep guards in place when sprayer is operating.
12. Be sure tank lid is closed before operating basket mixing facility.
13. Stand well clear of sprayer when operating.
14. Do not disconnect hoses, nozzles or filters while sprayer is operating.

FAILURE TO FOLLOW THE ABOVE INSTRUCTIONS MAY RESULT IN SERIOUS INJURY OR DEATH.

Croplands Equipment Pty Ltd XD123MS

Once the pre-operation checklist on page 43 has been completed, and chemical mixture is in the tank, proceed to spray:

- Anyone operating this sprayer must be conversant with the Croplands Safety manual.
- Spray operations should be done in conjunction with an agronomist / spray manager / someone skilled in the art of spraying and operating machinery.

The spray manager will have predetermined the job requirements, such as

- The block to be sprayed, and hence row width and any special instruction on boom / fan setup
- Operating speed (often around 8 Kph)
- Application rate (for example 500 L / Hectare)
- The nozzles to be used / which spray rings / Tier
- Spray pressures to be used (often around 5~8 bar)
- PTO and Spray pump rpm (often between 450 & 540)

Most of these parameters should be loaded into the Fusion controller whilst back at base / filling the sprayer.

Operating Pointers

- Always drive to the conditions taking into account the load, the terrain and the weather.
- In mixed terrain, spray the flat ground before spraying the hills.
- Before engaging any hydraulics for the first time, double check that the pressure return lines are properly connected.

⚠ DANGER

THERE IS A RISK OF ROLLOVER WHEN OPERATING ON SLOPES

- Slow down for slopes exceeding 10°
- Do not operate on slopes exceeding 15°
- Slow down when operating on irregular surfaces

FAILURE TO COMPLY WITH THESE PRECAUTIONS MAY RESULT IN DEATH OR INJURY



Croplands Equipment Pty Ltd XB-194

SECTION 6

SPRAY OPERATIONS

- When preparing to spray in row for the first time, stop – open the boom and check that all row widths and alignments are correct. Check that all tank lids are closed and the Tank Selection Valve is in the SPRAY position. Double check the rate controller setting – now ready to spray.

While spraying, continually ensure that:

- Engine and PTO speed are correct
- Correct operating pressure is being maintained
- Ground speed is correct and constant
- Quantum Mist Spray fans are operating correctly and aimed toward the target foliage.

FLUSHING

Quantum Mist sprayers are equipped with a flushing tank for cleaning the sprayer when changing chemicals, and at the end of the day.

To flush the Quantum Mist:

1. Ensure the site for flushing and cleaning the sprayer meets with environmental and statutory regulations
2. Open the tank drain valve and drain the remaining spray mixture from the tank
3. Open the Tank Selection valve to the FLUSH position, as shown
 - Be aware that the flushing tanks may need to be refilled during the process
 - Note the 4000L sprayer has an additional flush system via a Camlock connection.

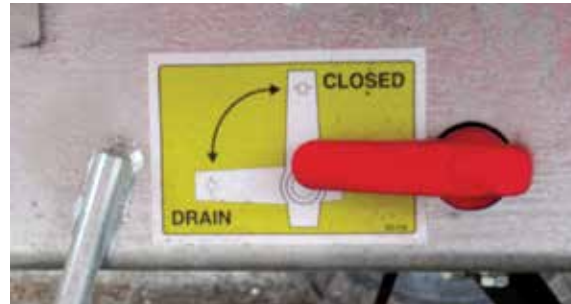

4. Open the mixing basket valve
5. Open the agitator valves
6. Start the Tractor
7. Make sure the Fusion controller is NOT in Spray mode (MASTER is dull / not yellow), NO green section lights showing and in MANUAL mode). Confirm that TIER 3 is selected to enable both spray rings to be flushed.



8. Start the pump by engaging the Tractor remote (Micro Power Pack version) or PTO. Set to operate at your required rpm, usually between 450 and 540 rpm.
9. All pumped liquid is now being passed through the dump valve back into the tank. The system is not pressurised and tank agitators are not working.
10. Activate Fusion Master switch (will turn yellow). This will pressurise the system and operate the tank agitators & basket rinse. Flick taps off once the lines are flushed.
11. Adjust to normal operating pressure via arrows on the Fusion screen.

SECTION 6

SPRAY OPERATIONS

12. Turn the spray sections ON using the Joystick, TRIGGER DOWN.
(MASTER is yellow, in MANUAL plus green section lights ON).
 - a. Make sure the area around the fans is clear of bystanders.
 - b. Make sure the fans are downwind of the operator.



13. After sufficient flushing, turn OFF the spray sections using Joystick, TRIGGER DOWN.
14. Turn on the fan Spray ring flushing taps (photo shows the closed position).
15. TRIGGER DOWN / ON and flush the remainder of the spray ring.
16. TRIGGER DOWN / OFF, turn off spray ring drain taps.
17. Some water will have flowed back to the main tank due to the flushing actions and drained out of the tank through the drain outlet.
18. On completion of flushing, shut down all controls and disengage the PTO / hydraulic drive
19. Check and clean all filter screens as required.



20. Adjust all valves back to operating (non-flushing) mode:
 - a. Close mixing basket valve
 - b. Close tank drain valve
 - c. Open Tank Selection Valve to the SPRAY position
 - d. Open the agitator valves
21. Wash / hose down the outside of the sprayer.

TANK AND EQUIPMENT CLEANING

If a cleaning agent is required (refer to chemical label), as is often recommended when changing from one chemical group to another or as an end of season clean before storage.

Nufarm's Tank and Equipment Cleaner is a suitable cleaning agent. Note this product is available from Croplands Dealers under part code L-H9704.



SECTION 6

SPRAY OPERATIONS

Below is a guide procedure, but if in doubt, follow the instructions provided with the cleaner.

1. First completely flush the sprayer with water as outlined in the previous FLUSHING section. Then ...
2. Fill the spray tank with freshwater
3. Add cleaning agent into the mixer basket (use according to instructions)
4. Open the Tank Selection Valve to the SPRAY position
5. Open mixing basket valve
6. Open the agitator valves
7. Start the Tractor
8. Make sure the Fusion controller is NOT in Spray mode (MASTER is dull / not yellow), no green section lights showing and in Manual mode). Ensure tier 3 is selected to enable both spray rings to be flushed.
9. Start the pump by engaging the Tractor remote (Micro Power Pack version) or PTO. Set to operate at your required rpm, usually between 450 and 540 rpm.

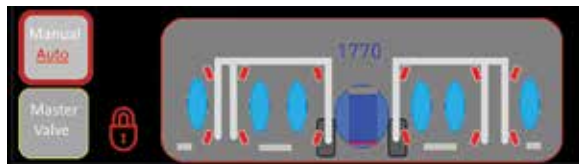

10. Activate Fusion Master switch (will turn yellow). This will pressurise the system and operate the tank agitators & basket rinse.
11. Adjust to normal operating pressure via arrows on the Fusion screen.
12. Turn the spray sections ON using the Joystick TRIGGER DOWN. (MASTER is yellow, in MANUAL plus green section lights ON).
 - a. Make sure the area around the fans is clear of bystanders.
 - b. Make sure the fans are downwind of the operator.
13. Turn OFF the spray sections using Joystick TRIGGER DOWN once sufficiently flushed.
14. If you require the cleaning agent to soak or stand for a period, turn the spray booms OFF and completely shut down the sprayer for a period
15. When soaking is completed, start the machine following steps to flush the tank and spray lines

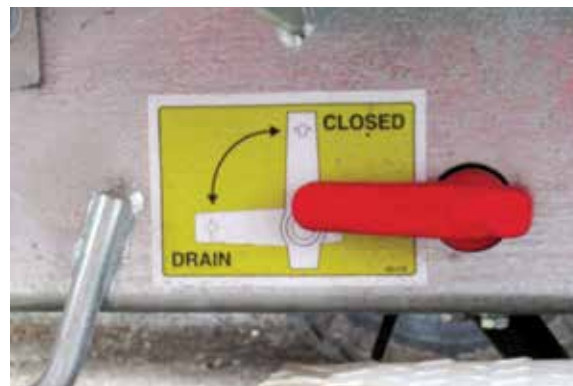

16. On completion of flushing, shut down all controls and disengage the PTO / hydraulic drive.
17. Open spray tank drain valve and allow cleaning mixture to drain from the tank
18. Delay the final flushing of the sprayer (again) with freshwater as outlined in the previous FLUSHING section, until just before the sprayer is next used – that might be in 1 hour or 6 months away if the sprayer is going into storage for the off season.



SECTION 7

SPRAYING INFORMATION

SPRAYWISE	55
CALIBRATION	55
FLOWMETER CALIBRATION	56
STEP 1 - ENSURE EQUIPMENT IS IN GOOD WORKING ORDER	56
STEP 2 - DETERMINING THE ACTUAL SPEED OF TRAVEL	58
STEP 3 - DETERMINE SPRAYING VOLUME REQUIRED	58
STEP 4 - DETERMINE SPRAYER CONFIGURATION	58
STEP 5 - DETERMINE THE IDEAL SPRAY PRESSURE	59
STEP 6 - DETERMINE & SELECT CORRECT NOZZLES	59
STEP 7 - FIT & TEST SELECTED NOZZLES	60
STEP 8 - CALCULATE THE ACTUAL APPLICATION RATE	60
STEP 9 - IF THE TESTED RATE IS UNSATISFACTORY	61
STEP 10 - COVERAGE ASSESSMENT	62
STEP 11 - ADD THE CORRECT AMOUNT OF CHEMICAL TO THE TANK	62
STEP 12 - RECORD ALL DATA FOR FUTURE REFERENCE	63
CALIBRATION WORK SHEET	64

SECTION 7

SPRAYING INFORMATION

Spraying should be done in conjunction with an agronomist / spray manager / someone skilled in the art of spraying. The best setup might vary significantly from crop to crop, season to season etc.

SPRAYWISE

It's highly recommended that all operators of this sprayer and spray program managers should be fully conversant with the information supplied in the **Nufarm SprayWise Horticultural Application Handbook** (refer photo) before undertaking spray operations.

The book includes chapters discussing re;

- Droplet Size
- Nozzle Types
- Dilute Spraying
- Concentrate Spraying
- Coverage & Assessment
- Selecting Nozzles
- Drift
- Weather
- Adjuvants
- Formulations & Mixing Order
- Cleaning
- Calibration
- Record Keeping
- And more

This book is supplied with every Smart Sprayer, and is available from Croplands dealers, under the part number: SPRAYWISEHK at a very reasonable price.

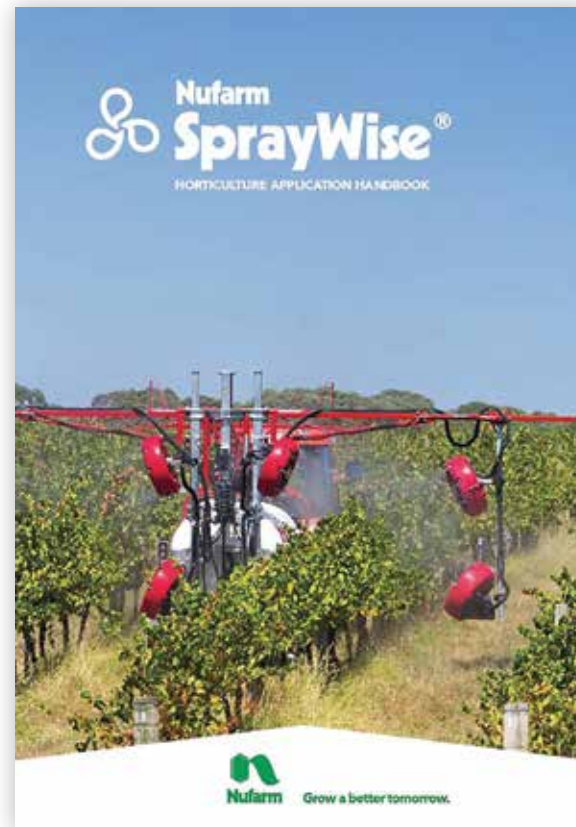

CALIBRATION

Applying the correct amount of chemical to a crop is only possible if **the sprayer is calibrated, operated and maintained correctly.**

The variables of spray application (distance, time, working width, liquid and chemical volumes) must be measured and controlled accurately to ensure chemicals are applied at the correct rate.

Proper calibration involves setting up the sprayer (nozzle selection, pressure, speed), calculating chemical and water rates and measuring the performance of the sprayer itself. Only then can you be totally confident in applying chemical correctly.

Fully Automatic Spray Controller (Fusion)

The Fusion fully automatic spray controller maintains the application rate (as set by the operator) when operated in the Auto position.

The controller monitors speed of travel (speed sensor) and flow rate (flow meter) and automatically adjusts flow rate (via a servo valve) to maintain correct application rate irrespective of speed variations within the limits of the nozzles used.

IMPORTANT:

- It should be remembered that the spray controller does not eliminate the necessity to measure and check the accuracy of nozzle spray patterns and outputs. These must be checked regularly to ensure correct and uniform application rates because nozzles wear with use.

SECTION 7

SPRAYING INFORMATION

- Flow meters used by the Quantum Mist Smart Sprayer need to be checked and calibrated on a regular basis.

The following page demonstrates how to maintain and check your Rapid-check flowmeter. It is recommended this is done regularly during the spraying season.



FLOWMETER CALIBRATION

As a part of the initial factory testing / calibration, a value (pulses per litre) will have been recorded and written on the body of the meter see example on page 32.

To check / improve the resolution of the flow meter calibration use the below method after having sprayed out a reasonable volume of liquid (the more sprayed the better the resolution);

- The current flow meter calibration number in the controller = X
- Take the total volume the controller says was sprayed and divided by the actual volume sprayed = Your new flow meter calibration.

- Then manually enter this number in the controller settings.

For example;

Current flow cal number (X) = 250. Controller says we have sprayed 4400L after having put 4000L in the tank.

$$250 \times 4400 = 1100000$$

$$1100000 / 4000 = 275 \text{ (new flow cal number)}$$

STEP 1 - ENSURE EQUIPMENT IS IN GOOD WORKING ORDER

Tank, pump, boom, filters and nozzles must be clean, free of leakages and functioning properly.

Follow the pre-operation checklist, maintenance and operating instructions in this manual.

Install, calibrate and operate the spray controller according to the spray controller operators manual.

A daily check & maintenance of flowmeter is to be performed every day after work is finished:

Daily Check & Maintenance of Flowmeter

This is to be performed every day after work is finished:

1. Unscrew the assembly that holds the Rapid Check unit in the body.
2. Remove the Rapid Check unit from the body.

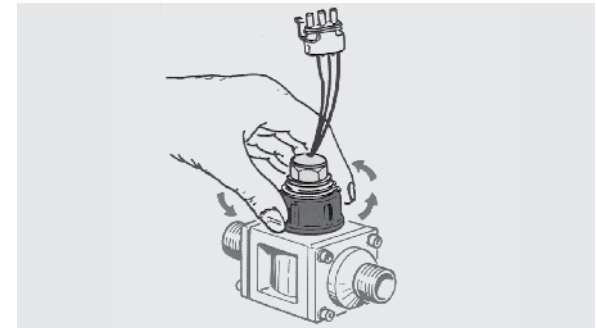

Unscrew the Rapid Check assembly

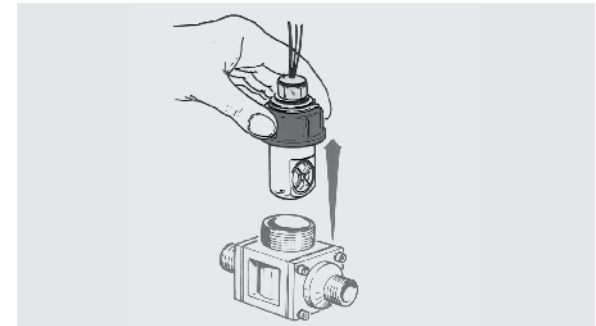

Remove the Rapid Check unit

3. Use clean water to wash any impurities out of the removable turbine unit.

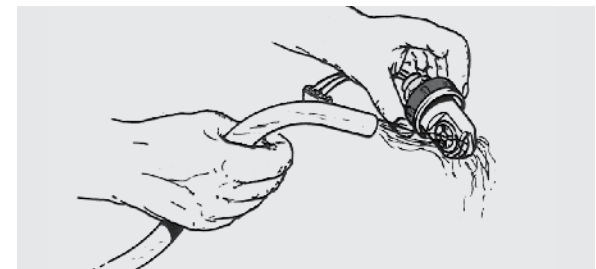

Wash any impurities out of the removable turbine unit

SECTION 7

SPRAYING INFORMATION

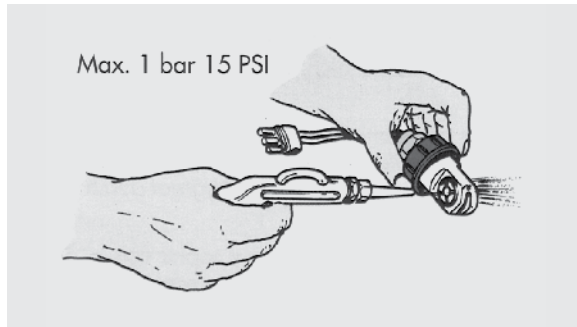

Use compressed air to check that the turbine unit rotates freely

4. Use compressed air to verify that the turbine unit rotates freely (maximum air pressure 1 BAR [15 psi]).

Every 50 Hours

Carry out the following procedure after every 50 hours of operation:

1. Unscrew the sensor.

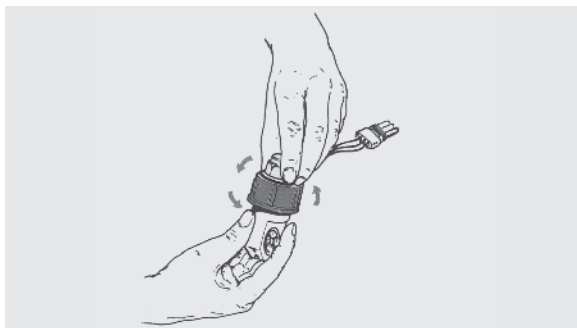

2. Separate the sensor from the Rapid Check unit.

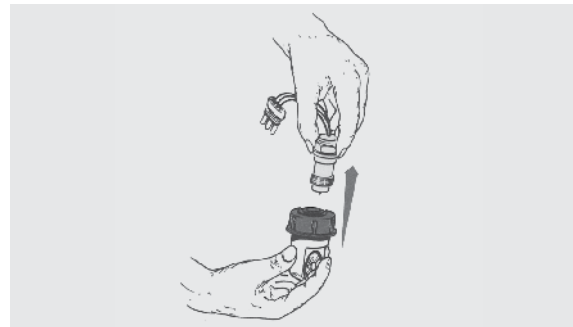

Separate the sensor from the Rapid Check unit

3. Place the Rapid Check unit in a detergent bath for a few hours.

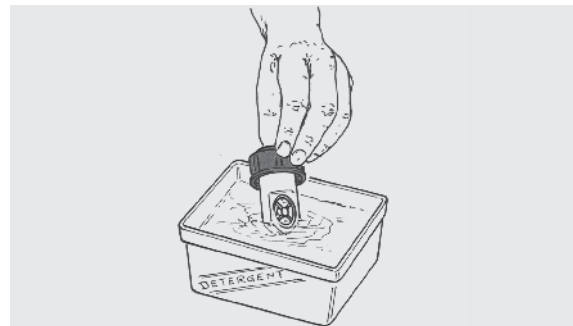

Place the Rapid Check unit in a detergent bath

4. Remove the Rapid Check unit from detergent bath.
Use compressed air to verify that the turbine unit rotates freely (maximum air pressure 1 BAR [15 psi]).
If necessary, replace the Rapid Check unit with a new one.

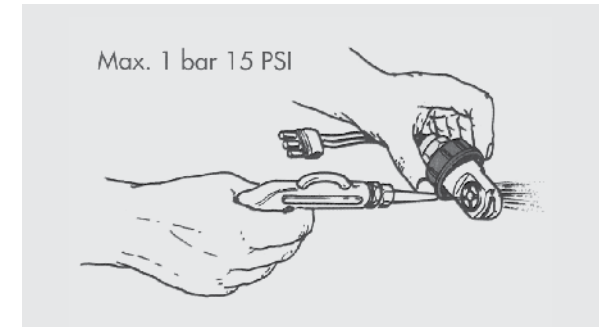

Use compressed air to check that the turbine unit rotates freely

SECTION 7

SPRAYING INFORMATION

STEP 2 - DETERMINING THE ACTUAL SPEED OF TRAVEL

Your sprayer has been factory set with a calibration number. This should be fine tuned prior to commencement of spraying and checked by your dealer. This is done by traveling a known distance (usually 100 metres) and comparing the distance measured by the Spray Controller to the known distance. If there is a discrepancy, the Spray Controller Manual explains how to easily adjust the calibration number automatically.

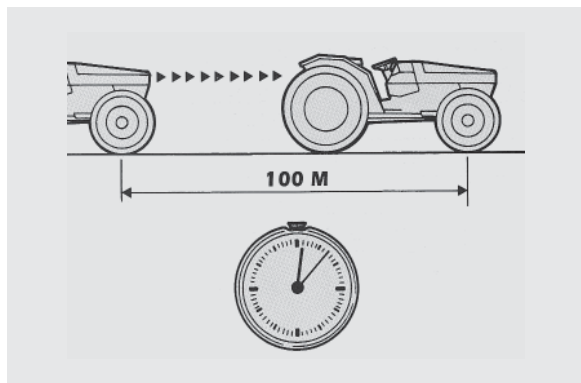

To manually check the speed...

- Half fill the sprayer tank with water and mark out a test strip of 100 metres (simulating spraying conditions).
- Set the sprayer operating and record the time taken to travel 100 metres at your required spraying speed.

c) Calculate the actual speed of travel using the formula:

For SPEED, km/hr = using the following formula:

$$\frac{\text{Distance (m)} \times 3.6}{\text{Time (sec)}}$$

eg. $100(\text{m}) \times 3.6 \div 48(\text{seconds})$
 $= 7.5\text{km/hr}$ travel speed

An alternative formula is:

$$\text{km/hr} = \text{Metres travelled in 1 minute}$$

STEP 3 - DETERMINE SPRAYING VOLUME REQUIRED

It is essential to determine the liquid volume per hectare required to effectively spray a crop without overspraying or underspraying.

The spray volume requirement should be determined by / in conjunction with an agronomist / spray manager / someone skilled in the art of spraying.

The term "litres per hectare" must be related to foliage and not just to land area. The amount of liquid needed to effectively spray any given crop will vary greatly with:

- The type of crop
- Row spacing
- Width of canopy
- Height of canopy
- Stage of growth
- Density of foliage

- Type of leaf surface
- Type of fruit (single or bunched)
- Type of sprayer used

STEP 4 - DETERMINE SPRAYER CONFIGURATION

Once the volume of required spray volume per hectare is established, the next step in setting up the sprayer is to determine:

- The **number of row(s)** to be sprayed in one pass, and
- The **total number of nozzles** to be used on the sprayer. Don't forget Tier 1, Tier 2 and Tier 3 options.

Both these factors can vary with the model of sprayer used and other factors mentioned under step 3.

Example A

A 2-row Smart Sprayer to spray vines – using 2 spray fan per Fan Frame, has a total of 8 spray fans.

Each spray fan has 2 spray rings - with 5 nozzles per ring. Hence a combined total of 40 nozzles per Tier (8 rings x 5 nozzles).

Therefore Tier 1 = 40 x nozzles, Tier 2 = 40 x nozzles & Tier 3 = 80 x nozzles.

Example B

A 3-row Smart Sprayer to spray vines – using 3 spray fan per Fan Frame, has a total of 18 spray fans.

Each spray fan has 2 spray rings - with 5 nozzles per ring. Hence a combined total of 90 nozzles per Tier (18 rings x 5 nozzles).

Therefore Tier 1 = 90 x nozzles, Tier 2 = 90 x nozzles & Tier 3 = 180 x nozzles.

SECTION 7

SPRAYING INFORMATION

The choice of nozzles (step 5 below) will influence decisions re the Sprayer's Tier configuration.

STEP 5 - DETERMINE THE IDEAL SPRAY PRESSURE

Before determining the correct nozzles, it's best to have an idea of the spray pressure required. Croplands recommends operating spray pressures between 5-10 bar. Setting up the sprayer at approximately 7 to 8 bar will allow lower pressures (say 5 or 6 bar) to be used in early season and higher pressures (say 9 or 10 bar) for later in the season without having to change nozzles mid season. It will also offer some margin around travelling slower or faster than the chosen speed.

The advice provided above is general information only and operators should seek specialised advice from their agronomist / spray manager / someone skilled in the art of spraying.

NOTE; when determining the optimum nozzles for both spray rings (Tiers 1 & 2), all calculations should be done at the same pressure.

STEP 6 - DETERMINE & SELECT CORRECT NOZZLES

Knowing actual travel speed, application rate required, number of rows to be sprayed in one pass, total number of nozzles to be used and ideal spray pressure, we can determine the nozzles required for the sprayer.

The calculation formulation is;

$$\frac{\text{Litres/Minute/Nozzle}}{\text{(Litres per minute per nozzle)}} = \frac{\text{Litres/Ha} \times \text{Km/hr} \div 600}{\text{total number of nozzles used} \times \text{row spacing (m)} \times \text{number of rows in one pass}}$$

CROPLANDS

Quantum Mist ALBUZ Nozzle Selection Worksheet

Step 1:

Enter data in grey boxes

Formula			
Target rate (L/ha)	<input type="text" value="650"/>	Speed (km/hr)	<input type="text" value="7.5"/>
Row spacing (m)	<input type="text" value="3"/>	Number of rows	<input type="text" value="1"/>
Number of nozzles	<input type="text" value="40"/>		
Total L/min =		24.375	L/min per nozzle
			0.61

Step 2:

Select nozzles from chart

ALBUZ NOZZLE	PART NUMBER	MESH	5 Bar	6 Bar	7 Bar	8 Bar	9 Bar
WHITE	AZ-ATR-WE-80C	100	0.27	0.29	0.32	0.34	0.36
LILAC	AZ-ATR-LC-80C	50	0.36	0.39	0.42	0.45	0.48
BROWN	AZ-ATR-BN-80C	50	0.48	0.52	0.56	0.60	0.64
YELLOW	AZ-ATR-YW-80C	50	0.73	0.80	0.86	0.92	0.97
ORANGE	AZ-ATR-OE-80C	50	0.99	1.08	1.17	1.24	1.32
RED	AZ-ATR-RD-80C	50	1.38	1.51	1.62	1.73	1.83
GREY	AZ-ATR-GY-80C	50	1.5	1.63	1.76	1.87	1.98
GREEN	AZ-ATR-GN-80C	50	1.78	1.94	2.09	2.22	2.35
BLACK	AZ-ATR-BK-80C	50	2	2.18	2.35	2.50	2.64
BLUE	AZ-ATR-BE-80C	50	2.45	2.67	2.87	3.06	3.24

NOTE; it's easiest to make the calculations based on each individual spray ring volume and then combine both rings. Always select nozzles using the same pressure.

For example, using Example A from the previous pages

- Row spacing = 3.0m
- Number of rows = 2
- Number of nozzles = 40
- Speed = 7.5 kph
- Ideal pressure 7 ~ 8 bar
- Tier 1 target rate = 300 L/ha
- Tier 2 target rate = 450 L/ha
- Tier 3 target rate = 750 L/ha

Using the above formula

300 (target rate) x 7.5 (speed) ÷ 600 ÷ 40 (number of nozzles) x 3.0 (row spacing) x 2 (no. of rows) = 0.56 Litres per minute per nozzle.

Once the flow rate per nozzle is known select the most appropriate nozzle from a flowrate chart for the nozzle being used. Flowrate charts are available from relevant nozzle suppliers. Croplands supplies and recommends the ALBUZ ATR Hollow Cone Nozzles for the Quantum Mist Sprayers.

Pictured left and overleaf are screenshots taken from a small spreadsheet program freely available from the Croplands Web Site or Croplands Customer Service titled "ALBUZ QM Nozzle Selection Worksheet" which makes it much quicker to calculate nozzle requirements. For more nozzles see the Croplands Optima buyers guide.

SECTION 7

SPRAYING INFORMATION

In the example on the previous page the **correct nozzle** for Tier 1 is the ALBUZ Brown operating at 7 Bar.

In the sample below, the **correct nozzle** for Tier 2 is the ALBUZ Yellow operating at 7 bar. Note the formula requires 0.84 L/min, and the nozzle flowchart shows 0.86 L/min. This nozzle with a marginal decrease in pressure will meet our requirements.

CROPLANDS

Quantum Mist ALBUZ Nozzle Selection Worksheet

Step 1:

Enter data in grey boxes

Formula			
Target rate (L/ha)	<input type="text" value="650"/>	Speed (km/hr)	<input type="text" value="7.5"/>
Row spacing (m)	<input type="text" value="3"/>	Number of rows	<input type="text" value="1"/>
Number of nozzles	<input type="text" value="40"/>		
Total L/min =	24.375	L/min per nozzle	0.61

Step 2:

Select nozzles from chart

ALBUZ NOZZLE	PART NUMBER	MESH	5 Bar	6 Bar	7 Bar	8 Bar	9 Bar
WHITE	AZ-ATR-WE-80C	100	0.27	0.29	0.32	0.34	0.36
LILAC	AZ-ATR-LC-80C	50	0.36	0.39	0.42	0.45	0.48
BROWN	AZ-ATR-BN-80C	50	0.48	0.52	0.56	0.60	0.64
YELLOW	AZ-ATR-YW-80C	50	0.73	0.80	0.86	0.92	0.97
ORANGE	AZ-ATR-OE-80C	50	0.99	1.08	1.17	1.24	1.32
RED	AZ-ATR-RD-80C	50	1.38	1.51	1.62	1.73	1.83
GREY	AZ-ATR-GY-80C	50	1.5	1.63	1.76	1.87	1.98
GREEN	AZ-ATR-GN-80C	50	1.78	1.94	2.09	2.22	2.35
BLACK	AZ-ATR-BK-80C	50	2	2.18	2.35	2.50	2.64
BLUE	AZ-ATR-BE-80C	50	2.45	2.67	2.87	3.06	3.24

Across the spraying season the variables (such as rates and speeds) may often change. With a well setup system small variations will be easily accommodated. Larger variations may require a change of nozzles.

STEP 7 - FIT & TEST SELECTED NOZZLES

The most important calibration is to test for the actual litres per hectare achieved through your sprayer.

- Use the following method to fit and test the selected nozzles:
- Fit selected nozzles to the sprayer.
- Fill your spray tank to overflowing & set the specified pump pressure and operate the sprayer for a short period to make sure all lines are full and nozzles are working properly (no blockages, leaks etc).
- Stop the sprayer and top up the tank with water to overflowing again.
- Operate the sprayer in the stationary position at the required pressure for not less than one minute.
- Measure how much water is required to refill the tank to the brim.
- Now, divide the volume measured by the time taken (minutes). The longer the test time the more accurate the figure.

The calculation formulation is;

Output (L/min) =

$$\frac{\text{Output (litres)}}{\text{Time (minutes)}}$$

Example 1, testing Tier 1, refer page 59, step 1.

$$\frac{28.5 \text{ litres}}{1.25 \text{ minutes (75 seconds)}} = 22.8 \text{ litres/min.}$$

Which is slightly more than the target of 22.4L/min (0.56 L/min per nozzle x 40 nozzles for 1.0 min)

Example 2, testing Tier 2, refer this page, step 1.

$$\frac{42.1 \text{ litres}}{1.25 \text{ minutes (75 seconds)}} = 33.7 \text{ litres/min.}$$

(note 0.86 L/min per nozzle x 40 nozzles for 1.0 min = 34.4 L/min)

- Excessive output is a sign of worn nozzles. See steps 8 & 9.
- Insufficient output is a sign of blockages. See steps 8 & 9.

STEP 8 - CALCULATE THE ACTUAL APPLICATION RATE

Actual application rate is the objective of setting up and calibrating your sprayer.

SECTION 7

SPRAYING INFORMATION

To calculate actual application rate (litres per hectare), use the following formula:

$$\text{Application Rate (L/ha)} = \frac{\text{Total sprayer output (L/min)} \times 600 \div \text{speed (Km/hr)} \div \text{row spacing (m)} \div \text{number rows in one pass}}{}$$

Example 1 (as per Tier 1 example)

$$\frac{22.8 \text{ (L/min)} \times 600 \div 7.5 \text{ km/hr} \div 3 \text{ m (row spacing)} \div 2 \text{ (rows/pass)}}{=} = 304 \text{ litres/ha}$$

Example 2 (as per Tier 2 example)

$$\frac{33.7 \text{ (L/min)} \times 600 \div 7.5 \text{ km/hr} \div 3 \text{ m (row spacing)} \div 2 \text{ (rows/pass)}}{=} = 449 \text{ litres/ha.}$$

STEP 9 - IF THE TESTED RATE IS UNSATISFACTORY

If your tested application rate does not meet your requirements, your options are:

A) In Auto mode - if application rate is not being achieved:

- Operating pressure will climb if nozzles are too small or blocked or speed is too fast.

Likewise, if your pressure filter is blocked (even partially), you may experience excessive pressure at the pump.

Make adjustments accordingly.

- Operating pressure will fall if nozzles are too large or speed is too slow. Make adjustments accordingly.

B) In Manual mode - the Controller application rate can be altered by:

- Adjusting pressure up or down to increase or decrease rate of application (use +/- keys).
- Adjusting spraying speed up or down to decrease or increase rate of application.

- Changing to a different nozzle capacity.

Repeat necessary testing procedures and calculation of application rate if adjustments or changes are made

LITRES PER 100 METRES / ROW

Many Auto Rate controllers, including the Fusion controller have an option for Litres per 100 metres and is occasionally the unit of preference in some vineyard operations. It's a simpler formula as row width is not relevant.

The calculation requires volume and distance, such as 11 litres per 100 metres (of rows). The operator only needs to follow the chemical label rate for mixing concentrate per 100 L.

Litres / Hectare conversion to Litres/ 100m																					
Table unit = L/100 m																					
Row Spacing (metres)																					
	2.0	2.1	2.2	2.3	2.4	2.5	2.6	2.7	2.8	2.9	3	3.1	3.2	3.3	3.4	3.5	3.6	3.7	3.8	3.9	4.00
250	5.0	5.3	5.5	5.8	6.0	6.3	6.5	6.8	7.0	7.3	7.5	7.8	8.0	8.3	8.5	8.8	9.0	9.3	9.5	9.8	10.0
300	6.0	6.3	6.6	6.9	7.2	7.5	7.8	8.1	8.4	8.7	9.0	9.3	9.6	9.9	10.2	10.5	10.8	11.1	11.4	11.7	12.0
350	7.0	7.4	7.7	8.1	8.4	8.8	9.1	9.5	9.8	10.2	10.5	10.9	11.2	11.6	11.9	12.3	12.6	13.0	13.3	13.7	14.0
400	8.0	8.4	8.8	9.2	9.6	10.0	10.4	10.8	11.2	11.6	12.0	12.4	12.8	13.2	13.6	14.0	14.4	14.8	15.2	15.6	16.0
450	9.0	9.5	9.9	10.4	10.8	11.3	11.7	12.2	12.6	13.1	13.5	14.0	14.4	14.9	15.3	15.8	16.2	16.7	17.1	17.6	18.0
500	10.0	10.5	11.0	11.5	12.0	12.5	13.0	13.5	14.0	14.5	15.0	15.5	16.0	16.5	17.0	17.5	18.0	18.5	19.0	19.5	20.0
550	11.0	11.6	12.1	12.7	13.2	13.8	14.3	14.9	15.4	16.0	16.5	17.1	17.6	18.2	18.7	19.3	19.8	20	21	21	22
600	12.0	12.6	13.2	13.8	14.4	15.0	15.6	16.2	16.8	17.4	18.0	18.6	19.2	19.8	20	21	22	23	23	24	24
650	13.0	13.7	14.3	15.0	15.6	16.3	16.9	17.6	18.2	18.9	19.5	20	21	21	22	23	23	24	25	25	26
700	14.0	14.7	15.4	16.1	16.8	17.5	18.2	18.9	19.6	20	21	22	22	23	24	25	25	26	27	27	28
750	15.0	15.8	16.5	17.3	18.0	18.8	19.5	20	21	22	23	23	24	25	26	26	27	28	29	29	30
800	16.0	16.8	17.6	18.4	19.2	20	21	22	22	23	24	25	26	26	27	28	29	30	30	31	32
850	17.0	17.9	18.7	19.6	20	21	22	23	24	25	26	26	27	28	29	30	31	31	32	33	34
900	18.0	18.9	19.8	21	22	23	23	24	25	26	27	28	29	30	31	32	32	33	34	35	36
950	19.0	20	21	22	23	24	25	26	27	28	29	29	30	31	32	33	34	35	36	37	38
1000	20	21	22	23	24	25	26	27	28	29	30	31	32	33	34	35	36	37	38	39	40
1100	22	23	24	25	26	28	29	30	31	32	33	34	35	36	37	39	40	41	42	43	44
1200	24	25	26	28	29	30	31	32	34	35	36	37	38	40	41	42	43	44	46	47	48
1300	26	27	29	30	31	33	34	35	36	38	39	40	42	43	44	46	47	48	49	51	52
1400	28	29	31	32	34	35	36	38	39	41	42	43	45	46	48	49	50	52	53	55	56
1500	30	32	33	35	36	38	39	41	42	44	45	47	48	50	51	53	54	56	57	59	60

SECTION 7

SPRAYING INFORMATION

Flowrate conversion charts are available in the Nufarm SprayWise Horticultural application handbook and the Croplands Optima spray range buyers guide.

Example 1 (as per Tier 1 example)

Using the chart above, 300 Lt / ha x 3m rows correlates to 9 litres per 100 metres of row.

STEP 10 - COVERAGE ASSESSMENT

Operate your sprayer in the required orchard or vineyard to check the actual spray coverage achieved on foliage.

This is important because it is the only real measure you have of actual coverage and effective penetration of your sprayer.

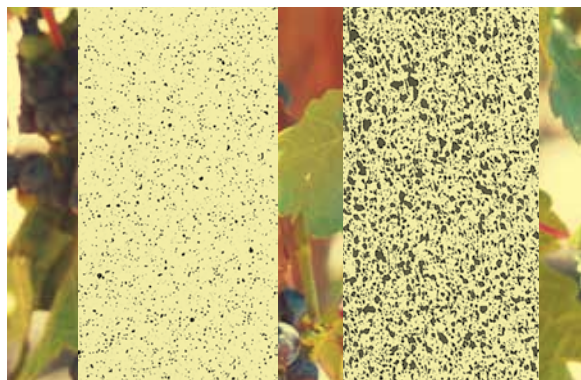

Coverage checks can be done using:

- Water Sensitive Papers (as pictured) and available through Croplands dealers – see Croplands Optima Buyers guide for further details.

- Clay Markers as available through Croplands dealers – see Croplands Optima Buyers guide for further details.
- Fluorescent Dye system as available through Croplands dealers – see Croplands Optima Buyers guide for further details.

It is recommended to test the unit using water only as a test run, and again when applying your chemical mixture.

Ensure water sensitive papers are strategically placed on both upper and lower surfaces.

Spraying testing, evaluation and adjustment to the sprayer (say fan positions) or spray settings (say nozzles, pressures and rates) should be done in conjunction with an agronomist / spray manager / someone skilled in the art of spraying. The best setup might vary significantly from crop to crop, season to season etc.

STEP 11 - ADD THE CORRECT AMOUNT OF CHEMICAL TO THE TANK

For land area rates (Litres or kg per hectare)

Use the following formula:

$$\text{Chemical required (Litres) =} \\ \frac{\text{Tank volume (Litres) x} \\ \text{recommended chemical rate (L/ha)}}{\text{spray application rate (L/ha)}}$$

For example;

$$\frac{2000 \text{ (litre tank) x } 2.0 \text{ (chemical rate L/ha)}}{50 \text{ (spray application rate L/ha)}} \\ = 80 \text{ litres of chemical}$$

If the chemical recommendation is given in water volume rates

Use the following formula:

$$\text{Chemical required (Litres) =} \\ \frac{\text{Tank volume (Litres) x} \\ \text{recommended chemical rate (L/100 litres)}}{100}$$

For example;

$$\frac{2000 \text{ (litre tank) x } 4 \text{ (chemical rate L/100 litres)}}{100} = 80 \text{ litres of chemical}$$

For tank volume required,

Use the following formula:

$$\text{Tank volume required (Litres) =} \\ \text{Area (ha) x spray application rate (L/ha)}$$

SECTION 7

SPRAYING INFORMATION

For example;

20 (hectares) x 50 (application rate, L/ha)
= 1000 litres of spray tank capacity required

STEP 12 - RECORD ALL DATA FOR FUTURE REFERENCE

Record all your calibration data on the worksheets given at the end of this section.

Photocopy the worksheets to obtain the number of work sheets required.



ALBUZ-ATR HOLLOW CANE NOZZLES

Features:

- Angle of 80° at 5 bar
- Easy dismantling for cleaning
- Hollow cone nozzle producing fine droplets
- AlbuZ durable pink ceramic allows precision high pressure spraying
- Polished ceramics ensure perfect sealing and precise flow rate.

Applications:

- For fungicides and insecticides
- Recommended for orchards and vineyards.

	ALBUZ NOZZLE	PART NUMBER	MESH	5 BAR	6 BAR	7 BAR	8 BAR	9 BAR	10 BAR	11 BAR	12 BAR
	WHITE	AZ-ATR-WE-80C	100	0.27	0.29	0.32	0.34	0.36	0.38	0.39	0.41
	LILAC	AZ-ATR-LC-80C	50	0.36	0.39	0.42	0.45	0.48	0.50	0.52	0.55
CURRENT STANDARD	BROWN	AZ-ATR-BN-80C	50	0.48	0.52	0.56	0.60	0.64	0.67	0.70	0.73
CURRENT STANDARD	YELLOW	AZ-ATR-YW-80C	50	0.73	0.80	0.86	0.92	0.97	1.03	1.07	1.12
	ORANGE	AZ-ATR-OE-80C	50	0.99	1.08	1.17	1.24	1.32	1.39	1.45	1.51
	RED	AZ-ATR-RD-80C	50	1.38	1.51	1.62	1.73	1.83	1.92	2.01	2.09
	GREY	AZ-ATR-GY-80C	50	1.50	1.63	1.76	1.87	1.98	2.08	2.17	2.26
	GREEN	AZ-ATR-GN-80C	50	1.78	1.94	2.09	2.22	2.35	2.47	2.58	2.69
	BLACK	AZ-ATR-BK-80C	50	2.00	2.18	2.35	2.50	2.64	2.78	2.90	3.03
	BLUE	AZ-ATR-BE-80C	50	2.45	2.67	2.87	3.06	3.24	3.40	3.56	3.71

SECTION 7

SPRAYING INFORMATION

CALIBRATION WORK SHEET

Step 1

Check the Sprayer is in Good Working Order

Step 2

Determine Actual Speed of Travel

Measure and mark a straight path of 100 metres (or more) of travelling conditions similar to the orchard or vine yard you are going to spray.

Half fill the spray tank & record the time (in seconds) to travel the measured distance.

Make sure that the tractor is travelling at spraying speed when you pass the start and finish marks and ensure the fan and pump are at operational speed.

If you have a hectare metre or automatic controller you need to check the speed calibration of the controller.

Tractor model	
Gear	
Range	
Dual power	
Engine RPM	
Speed in Km/h	

Kilometres per Hour = Distance traveled (m) x 3.6

Step 3

Determine Spraying Volume Required

It is essential to determine the liquid volume per hectare required to effectively spray a crop without overspraying or underspraying.

Use your own experience or a registered rate calibration consultant to determine effective volume in litres per hectare.

..... litres/ha

Step 4

Determine Sprayer Configuration

Number of row(s) to be sprayed in one pass

Total number of nozzles to be used:

Step 5

Determine & Select Nozzles

Determine nozzle flow rate required:

Litres/Minute/Nozzle

=

**Litres/Ha x Km/hr ÷ 600 ÷ Total
Number of Nozzles Used x Row
Spacing (m) x Number of Rows in
One Pass**

$$\text{[]} \times \text{[]} \div 600 \div \text{[]} \times \text{[]} \times \text{[]}$$

$$= \text{[]} \text{ litres/minute/nozzle}$$

Once the flow rate per nozzle is known, select an appropriate nozzle size from the nozzle charts.

Nozzle Selection

Step 6

Fit & Test Selected Nozzles

The most important calibration is to test for **actual litre per hectare**. Fill your spray tank to overflowing and run the sprayer for one minute, at the above operating settings, and record the total litres per minute used.

Output/min (l/min)

=

Output (litres) ÷ Time (minutes)

$$\text{[]} \div \text{[]} = \text{[]} \text{ litres/min}$$

Step 7

Calculate the Actual Application Rate

To calculate actual application rate (litres per hectare), use the following formula::

Application Rate (l/ha)

=

**Total Sprayer Output (l/min) x 600
÷ Speed (Km/hr) ÷ Row Spacing (m)
÷ Number Rows in One Pass**

$$\text{[]} \times 600 \div \text{[]} \div \text{[]} \div \text{[]}$$

$$= \text{[]} \text{ litres/ha}$$

Record your data:

Farm location	
Crop to be sprayed	
Canopy width (m)	
Canopy Height (m)	
Spray Volume litres/ha	
No. Rows in one pass	
No. of nozzles used	
Litres/minute/nozzle	
Nozzle pressure	
Nozzle type	
Nozzle size & colour	
Tested Output in l/min	
Actual Litres/Hectare	

Note: If your sprayer has a flow meter fitted, you should calibrate it regularly. The calibration setting on the tag is a factory setting only and needs to be regularly checked - taking into consideration changes in density and/or viscosity of the product to be sprayed.

SECTION 7

SPRAYING INFORMATION

CALIBRATION WORK SHEET

Step 1

Check the Sprayer is in Good Working Order

Step 2

Determine Actual Speed of Travel

Measure and mark a straight path of 100 metres (or more) of travelling conditions similar to the orchard or vine yard you are going to spray.

Half fill the spray tank & record the time (in seconds) to travel the measured distance.

Make sure that the tractor is travelling at spraying speed when you pass the start and finish marks and ensure the fan and pump are at operational speed.

If you have a hectare metre or automatic controller you need to check the speed calibration of the controller.

Tractor model	
Gear	
Range	
Dual power	
Engine RPM	
Speed in Km/h	

Kilometres per Hour = Distance traveled (m) x 3.6

Step 3

Determine Spraying Volume Required

It is essential to determine the liquid volume per hectare required to effectively spray a crop without overspraying or underspraying.

Use your own experience or a registered rate calibration consultant to determine effective volume in litres per hectare.

..... litres/ha

Step 4

Determine Sprayer Configuration

Number of row(s) to be sprayed in one pass	
Total number of nozzles to be used:	

Step 5

Determine & Select Nozzles

Determine nozzle flow rate required:

$$\frac{\text{Litres/Minute/Nozzle}}{=}$$

$$\frac{\text{Litres/Ha} \times \text{Km/hr} \div 600 \div \text{Total Number of Nozzles Used} \times \text{Row Spacing (m)} \times \text{Number of Rows in One Pass}}$$

$$\frac{\text{ } \times \text{ } \div 600 \div \text{ } \times \text{ } \times \text{ } = \text{ } \text{ litres/minute/nozzle}$$

Once the flow rate per nozzle is known, select an appropriate nozzle size from the nozzle charts.

Nozzle Selection	
------------------	--

Step 6

Fit & Test Selected Nozzles

The most important calibration is to test for **actual litre per hectare**. Fill your spray tank to overflowing and run the sprayer for one minute, at the above operating settings, and record the total litres per minute used.

$$\frac{\text{Output/min (l/min)}}{=}$$

$$\frac{\text{Output (litres)} \div \text{Time (minutes)}}{\text{ } \div \text{ } = \text{ } \text{ litres/min}}$$

Step 7

Calculate the Actual Application Rate

To calculate actual application rate (litres per hectare), use the following formula::

$$\frac{\text{Application Rate (l/ha)}}{=}$$

$$\frac{\text{Total Sprayer Output (l/min)} \times 600}{\div \text{Speed (Km/hr)} \div \text{Row Spacing (m)} \div \text{Number Rows in One Pass}}$$

$$\frac{\text{ } \times 600 \div \text{ } \div \text{ } \div \text{ } = \text{ } \text{ litres/ha}}$$

Record your data:

Farm location	
Crop to be sprayed	
Canopy width (m)	
Canopy Height (m)	
Spray Volume litres/ha	
No. Rows in one pass	
No. of nozzles used	
Litres/minute/nozzle	
Nozzle pressure	
Nozzle type	
Nozzle size & colour	
Tested Output in l/min	
Actual Litres/Hectare	

Note: If your sprayer has a flow meter fitted, you should calibrate it regularly. The calibration setting on the tag is a factory setting only and needs to be regularly checked - taking into consideration changes in density and/or viscosity of the product to be sprayed.

SECTION 7

SPRAYING INFORMATION

CALIBRATION WORK SHEET

Step 1

Check the Sprayer is in Good Working Order

Step 2

Determine Actual Speed of Travel

Measure and mark a straight path of 100 metres (or more) of travelling conditions similar to the orchard or vine yard you are going to spray.

Half fill the spray tank & record the time (in seconds) to travel the measured distance.

Make sure that the tractor is travelling at spraying speed when you pass the start and finish marks and ensure the fan and pump are at operational speed.

If you have a hectare metre or automatic controller you need to check the speed calibration of the controller.

Tractor model	
Gear	
Range	
Dual power	
Engine RPM	
Speed in Km/h	

Kilometres per Hour = Distance traveled (m) x 3.6

Step 3

Determine Spraying Volume Required

It is essential to determine the liquid volume per hectare required to effectively spray a crop without overspraying or underspraying.

Use your own experience or a registered rate calibration consultant to determine effective volume in litres per hectare.

..... litres/ha

Step 4

Determine Sprayer Configuration

Number of row(s) to be sprayed in one pass

Total number of nozzles to be used:

Step 5

Determine & Select Nozzles

Determine nozzle flow rate required:

Litres/Minute/Nozzle

=

**Litres/Ha x Km/hr ÷ 600 ÷ Total
Number of Nozzles Used x Row
Spacing (m) x Number of Rows in
One Pass**

$$\text{[]} \times \text{[]} \div 600 \div \text{[]} \times \text{[]} \times \text{[]}$$

$$= \text{[]} \text{ litres/minute/nozzle}$$

Once the flow rate per nozzle is known, select an appropriate nozzle size from the nozzle charts.

Nozzle Selection

Step 6

Fit & Test Selected Nozzles

The most important calibration is to test for **actual litre per hectare**. Fill your spray tank to overflowing and run the sprayer for one minute, at the above operating settings, and record the total litres per minute used.

Output/min (l/min)

=

Output (litres) ÷ Time (minutes)

$$\text{[]} \div \text{[]} = \text{[]} \text{ litres/min}$$

Step 7

Calculate the Actual Application Rate

To calculate actual application rate (litres per hectare), use the following formula::

Application Rate (l/ha)

=

**Total Sprayer Output (l/min) x 600
÷ Speed (Km/hr) ÷ Row Spacing (m)
÷ Number Rows in One Pass**

$$\text{[]} \times 600 \div \text{[]} \div \text{[]} \div \text{[]}$$

$$= \text{[]} \text{ litres/ha}$$

Record your data:

Farm location	
Crop to be sprayed	
Canopy width (m)	
Canopy Height (m)	
Spray Volume litres/ha	
No. Rows in one pass	
No. of nozzles used	
Litres/minute/nozzle	
Nozzle pressure	
Nozzle type	
Nozzle size & colour	
Tested Output in l/min	
Actual Litres/Hectare	

Note: If your sprayer has a flow meter fitted, you should calibrate it regularly. The calibration setting on the tag is a factory setting only and needs to be regularly checked - taking into consideration changes in density and/or viscosity of the product to be sprayed.

SECTION 7

SPRAYING INFORMATION

CALIBRATION WORK SHEET

Step 1

Check the Sprayer is in Good Working Order

Step 2

Determine Actual Speed of Travel

Measure and mark a straight path of 100 metres (or more) of travelling conditions similar to the orchard or vine yard you are going to spray.

Half fill the spray tank & record the time (in seconds) to travel the measured distance.

Make sure that the tractor is travelling at spraying speed when you pass the start and finish marks and ensure the fan and pump are at operational speed.

If you have a hectare metre or automatic controller you need to check the speed calibration of the controller.

Tractor model	
Gear	
Range	
Dual power	
Engine RPM	
Speed in Km/h	

Kilometres per Hour = Distance traveled (m) x 3.6

Step 3

Determine Spraying Volume Required

It is essential to determine the liquid volume per hectare required to effectively spray a crop without overspraying or underspraying.

Use your own experience or a registered rate calibration consultant to determine effective volume in litres per hectare.

..... litres/ha

Step 4

Determine Sprayer Configuration

Number of row(s) to be sprayed in one pass

Total number of nozzles to be used:

Step 5

Determine & Select Nozzles

Determine nozzle flow rate required:

Litres/Minute/Nozzle

=

**Litres/Ha x Km/hr ÷ 600 ÷ Total
Number of Nozzles Used x Row
Spacing (m) x Number of Rows in
One Pass**

$$\text{[]} \times \text{[]} \div 600 \div \text{[]} \times \text{[]} \times \text{[]}$$

$$= \text{[]} \text{ litres/minute/nozzle}$$

Once the flow rate per nozzle is known, select an appropriate nozzle size from the nozzle charts.

Nozzle Selection

Step 6

Fit & Test Selected Nozzles

The most important calibration is to test for **actual litre per hectare**. Fill your spray tank to overflowing and run the sprayer for one minute, at the above operating settings, and record the total litres per minute used.

Output/min (l/min)

=

Output (litres) ÷ Time (minutes)

$$\text{[]} \div \text{[]} = \text{[]} \text{ litres/min}$$

Step 7

Calculate the Actual Application Rate

To calculate actual application rate (litres per hectare), use the following formula::

Application Rate (l/ha)

=

**Total Sprayer Output (l/min) x 600
÷ Speed (Km/hr) ÷ Row Spacing (m)
÷ Number Rows in One Pass**

$$\text{[]} \times 600 \div \text{[]} \div \text{[]} \div \text{[]}$$

$$= \text{[]} \text{ litres/ha}$$

Record your data:

Farm location	
Crop to be sprayed	
Canopy width (m)	
Canopy Height (m)	
Spray Volume litres/ha	
No. Rows in one pass	
No. of nozzles used	
Litres/minute/nozzle	
Nozzle pressure	
Nozzle type	
Nozzle size & colour	
Tested Output in l/min	
Actual Litres/Hectare	

Note: If your sprayer has a flow meter fitted, you should calibrate it regularly. The calibration setting on the tag is a factory setting only and needs to be regularly checked - taking into consideration changes in density and/or viscosity of the product to be sprayed.

SECTION 8

SMART SPRAY RECAPTURE SYSTEM V2

If fitted, please refer to separate manual for the Smart Spray Recapture System - version 2 venturi system.

Note the model shown on the front cover is a prototype sprayer equipped with an original version recapture system.

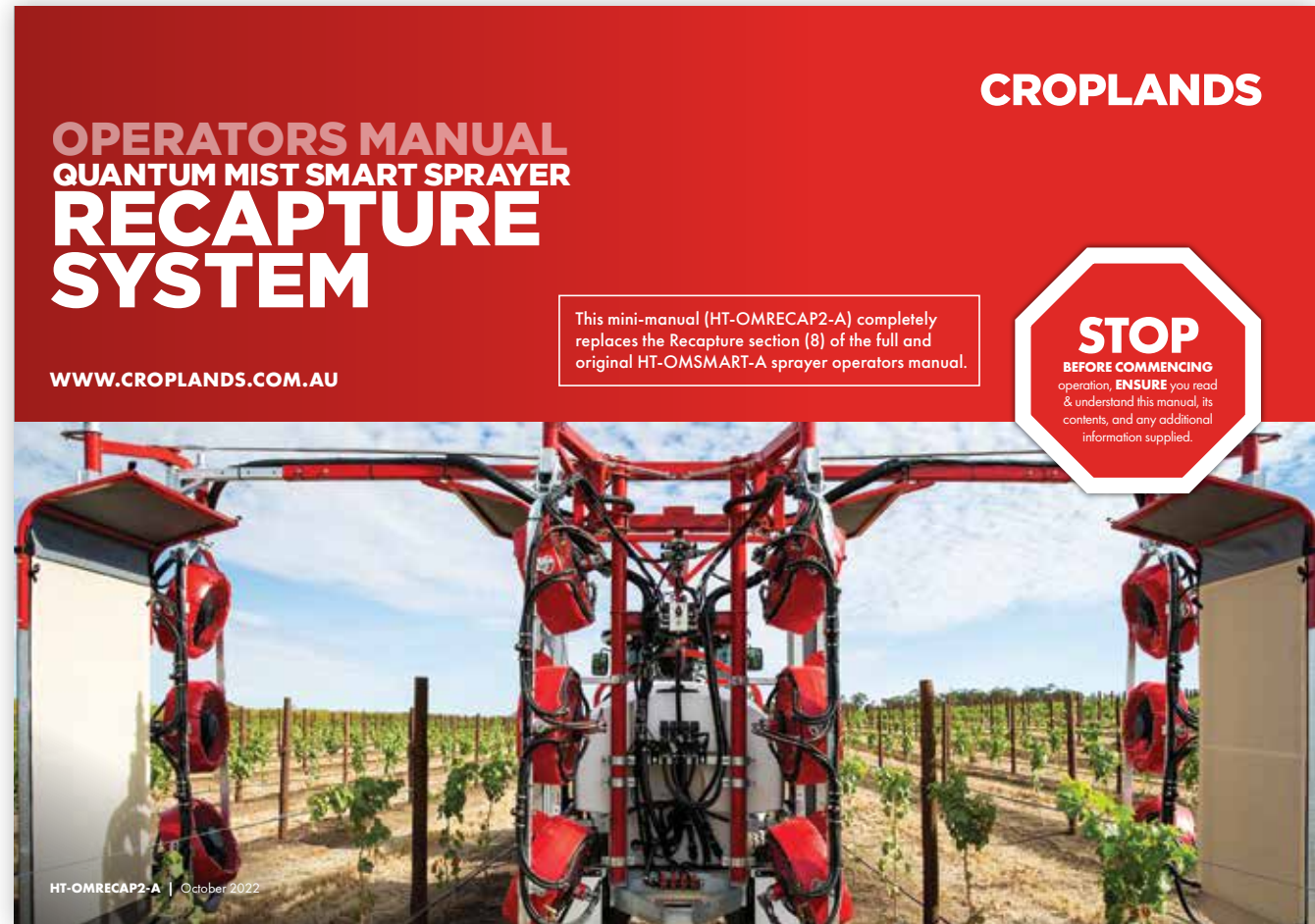

SECTION 9

LUBRICATION & MAINTENANCE

GREASING & SERVICE PROCEDURES	70
EVERY 200 HOURS	70
GREASE POINTS	70
DIAPHRAGM PUMPS	71
FILTERS	72
TOOLS	74

SECTION 9

LUBRICATION & MAINTENANCE

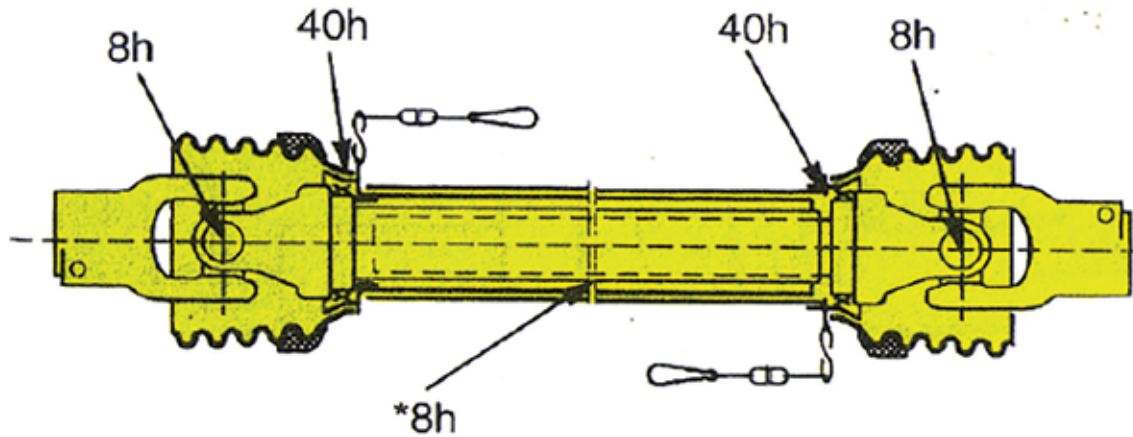

Grease the PTO shaft as shown. * Pull shaft apart - apply grease to the inside of the outer telescopic profile.

GREASING & SERVICE PROCEDURES

1. Clean suction line filter with each tank load.
2. Clean pressure line filter.
3. Check tyre pressure ((350kPa / 50 psi), and check wheel nuts.
4. Clean Rapid-check flowmeter (refer to page 56), if fitted.
5. Grease tractor to sprayer PTO universal joints every 8 hours. Grease lightly until grease becomes firm in seals. Over greasing will break seals and allow dust and moisture to penetrate - increasing wear.
6. Grease PTO inner tubes every 8 hours. To lubricate the inner tube, slide PTO shaft apart, clean the telescopic tubes, grease and reassemble.
7. Grease the PTO covers every 20 hours.
8. Ensure safety covers and safety chains are in place and in good working order
9. Grease self-steer drawbar every 20 hours.
10. Check pump air chamber pressure on a regular basis. As a general guideline it should be 10%-20% of operating pressure (70-100 kPa [10-15 psi]). Refer to pump manual for more information.
11. To ensure trouble free spraying, flush the sprayer with freshwater thoroughly each day, and before changing chemicals. Dispose of tank wash according to chemical manufacturers instructions.
12. Grease all boom joints, height adjuster points and other grease points).

EVERY 200 HOURS

1. Lubricate quick-release lock pins on PTO shaft.
2. Re-pack wheel bearings with grease.
3. Grease all tank lid seals with vaseline.
4. Check to ensure agitators have not become blocked with sulphur/chemicals.
5. Inspect all hydraulic lines for wear points.
6. Check pump mounts.
7. Check fan RPM and oil pressure at the test port.

GREASE POINTS

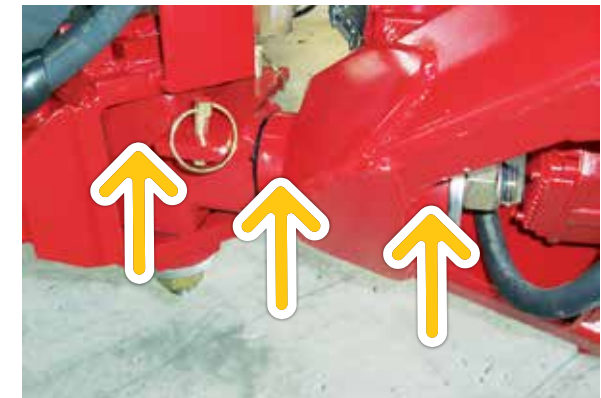

Grease all swivel drawbar grease points

1. Swivel eye on the drawbar, if fitted.
2. Wheel hubs, if fitted with grease nipples.

SECTION 9

LUBRICATION & MAINTENANCE



Grease the self-steer ball assembly regularly

3. PTO shaft - all crosses (knuckles), both ends and sliding tubes. Refer to page 70 for frequency.



Grease wheel hubs



AR185 - 180l/min diaphragm pump

DIAPHRAGM PUMPS

Diaphragm Pumps Maintenance

Annovi & Reverberi (A&R) pumps are of the piston-diaphragm type. All parts in contact with the spray liquid, which are subject to corrosion, are protected, making them ideal for spraying.

Daily Before Starting the Pump

1. Check that oil is visible in sight glass (half way up) and top up if necessary with good clean motor oil 20W/30 or 20W/40.
2. Clean all sprayer filters. Blocked or semi blocked filters place extra stress on diaphragms.
3. Start with zero pressure and the pump will self prime immediately and clear air locks in suction line.



Running a diaphragm pump faster than specified will not improve performance, but will damage and wear out moving parts. Warranty will be made void by speeds in excess of those indicated on the pump name plate.

Daily after Use

1. Flush pump with clean water.
2. Drain filters and clean. A high percentage of pump failures are due to blocked filters.

Every 50 Hours

Check surge chamber pressure and adjust as follows:

- Air pressure 70-100kPa (10-15psi) [Should be 10-20% of operating pressure].

Vibration of the delivery hose usually indicates that the air pressure in the surge chamber is incorrect.

The main cause of surge chamber diaphragm fracture is low pressure in this chamber.

Surge chamber pressure can be checked with an ordinary tyre gauge.

The above pressure range is a guide to the correct pressure.

However, if difficulties recur, adjust the pressure until an even flow is obtained from the pump (no pulsing of liquid at operating RPM). The pressure is best increased with a bicycle pump, hand pump or foot pump.

SECTION 9

LUBRICATION & MAINTENANCE

Every 250 hours or Every Season - Whichever Comes Sooner

1. Change oil and refill with 20W/30 oil. Attention should be made to remove trapped air behind the diaphragms by rocking from side to side as instructed.
It is also good practise run the pump for 10 minutes without pressure, and then, top up with oil before working the pump.
2. When changing the pump oil, check diaphragms and replace them if they are showing signs of wear.
Diaphragm valves should be replaced every 400 hours regardless of wear.
This is normally a pre-season maintenance procedure which can be done easily as no special tools are required.
You can avoid unnecessary down time in spraying seasons by carrying out preventative maintenance.
3. Also check inlet and outlet valves and replace if worn. Worn valves not only reduce the output of the pump, but may reduce the life of the diaphragms.

Excessive Diaphragm Failure

If you have excessive diaphragm failure check the following points. These will cause failure of diaphragms due to added stress or chemical attack.

1. Most Important - Pump not being flushed out daily with clean water after use.
2. Oil level too low allowing air between piston and diaphragm.
3. Air leaks in suction line.
4. Restricted suction line.
5. Restriction through suction filter.
6. Not cleaning suction filter regularly.
7. Worn suction and discharge valves.
8. Bypass line too small to carry full capacity of pump.
9. In cold climates - frozen suction/discharge lines or water remaining in the pump after flushing.
10. Incorrect air setting or no air in air chamber.
11. Agitator excessively restricting bypass from pump.
12. Diaphragm material construction incorrect for chemical or solution being pumped.
13. Chemicals containing toluene or other aggressive solvents may require viton diaphragms - particularly if the pump is not properly flushed after use.

Pre-Season Servicing

For thorough pre-season servicing - check all aspects of the Quantum Mist and its operating components as outlined in the pre-delivery check list.

Pump Storage and Corrosion Protection

1. Warm Climates

If you operate in a warm climate with no chance of frost in the winter, you will not have any problems with frost damage.

If you are storing your sprayer between seasons, ensure your pump has been thoroughly flushed with clean water. A good idea is to run a mixture of 1% solution of summer mineral spraying oil through the pump and plumbing system. Summer spraying oil is water-soluble oil such as DC-Tron. This will coat and protect all internal pump parts. Ensure this mixture is flushed out before spraying commences in the new season.

2. Cold Climates

For prolonged storage, an anti-freeze mixture can be flushed through the pump. Ensure this is thoroughly flushed out prior to the commencement of spraying again.

If the pump is being stored overnight and a risk of freezing is imminent, drain all liquid from the pump and lines, including boom lines.

FILTERS

Filter Maintenance

Clean filters ensure that no solids enter the spraying system to block or damage pump or nozzles.

All filters should be cleaned regularly or after each spraying period.



The pump suction valve CLOSED to the main tank

Suction Filter

The suction filter should be cleaned regularly, or after each spray tank has been emptied.

SECTION 9

LUBRICATION & MAINTENANCE

To clean the filter:

1. Completely stop all sprayer functions.
2. Place the tank selection valve in the closed position to shut off liquid from the main tank.
3. Remove the outer filter screw and bowl.



Remove the outer filter screw and bowl

4. Remove the filter screen & thoroughly clean it and other components before reassembling the filter.



Remove & clean the filter element & components

5. Carefully reassemble the filter, ensuring the screen O-Rings are in place, and then, tighten the outer filter screw so that the outer O-ring is properly sealed.



Reassemble and tighten the outer filter screw.

6. **Open the tank selection valve** to access liquid from the main tank, then check the filter is sealed correctly. If leaking, further tighten the outer screw until sealed. If this does not stop the leaking, check the alignment of the O-ring and/or the condition of the O-ring. Replace if necessary.

Vaseline is the best lubricant for filter seals.



Open & close the filter tap while system is pressurised

NOTE

Be careful not to damage or deform the mesh or O-ring while cleaning and refitting the suction filter. If the filter screen or O-ring is damaged, replace the part.

In-line Pressure Filters

The in-line pressure filter should be cleaned regularly, or after each spray tank has been emptied.

To flush each filter, open and close the filter tap while the system is pressurised.

The filter & bowl assembly will need to be disassembled for thorough cleaning.

CAUTION

Ensure the TANK SELECTION VALVE IS OPEN before starting the pump. Starting the pump with the Tank Selection valve closed will seriously damage the suction valve and warranty will be made void.

For Major Servicing follow the pre-delivery Checklist that came with the sprayer.

SECTION 9

LUBRICATION & MAINTENANCE

TOOLS

RP-076

QM-420 Nozzle Cap Tool

Supplied free with every new Smart Sprayer (2022+)



Refer to customer service for more details.

RP-095

Speed Sensor Installation Kit

CROPLANDS

RP-095 KIT / QM-420 SPEED SENSOR INSTALLATION

Replacing the rpm sensor (UP-402) to the Quantum Mist 420 drive body can be very challenging, especially whilst on the sprayer.

There is an easy way, but first you need the correct tools, as per the RP-095 kit – the kit components are;

- 1) A tap to clean out the thread. It's an unusual size, M12 x 1.0
- 2) A modified 17mm Flare Nut Socket to suit the purpose.

(A) remove the rear guard (4 screws) and (B) remove the rear cover (4 screws). Note the fans are always installed with the sensor facing downwards. Remove the existing brass socket or old sensor. Clean up the thread using the **supplied tap**. Be careful to not push swarf inside the drive body.

Check for the correct depth. Finding the correct depth and position of the "pickup" (circled in red) of the drive coupling is critical. It's best to find the pickup position before installing the sensor using a soft round object (dowel, pencil etc) and be aware of this position as the sensor is being screwed (gently, by hand) into the drive body.

Correct positioning of the sensor is approximately 2 turns away from the pickup. Too far away and the sensor won't work – too close and the screw head will damage the sensor. Once correct (depth) position is confirmed, use the socket tool to tighten the first and then the second (lock) nuts.

Reinstall rear cover & rear guard.



Document Date 11/10/2022 **Product Information** Specifications subject to change without notice Page 1 of 1

SECTION 10

TROUBLESHOOTING

DIAPHRAGM PUMP PROBLEMS

PROBLEM	PROBABLE CAUSE	REMEDY
A. Pump does not draw or deliver liquid. Pressure gauge fluctuates badly	<ol style="list-style-type: none"> 1. The pump is sucking in air through suction line. 2. Air has not been entirely evacuated from the pump. 3. Blocked suction filter. 4. Damaged or worn suction valves. 	<ol style="list-style-type: none"> 1. Examine the suction hose and ensure it is firmly secured. 2. Rotate the pump with outlet hose and taps open. 3. Clean suction filter. 4. Replace suction valves.
B. Liquid flow is irregular (Also check items under A)	<ol style="list-style-type: none"> 1. The air in the air chamber of the pump is incorrectly set. 2. Diaphragm split. 3. Damaged or worn valves. 4. Foreign matter holding valves open. 	<ol style="list-style-type: none"> 1. Check pressure in air chamber of pump. Set as required (refer p.49). 2. Replace diaphragm. 3. Replace valves. 4. Clean valves.
C. Pump delivers insufficient pressure	<ol style="list-style-type: none"> 1. Regulating valve: <ul style="list-style-type: none"> • Sticking open • Not set for pressure • Damaged or worn seat or spring 2. Cylinder diaphragm ruptured. 3. Pump valves blocked, worn or damaged. 4. Spray nozzles worn, missing or exceed pump capacity. 	<ol style="list-style-type: none"> 1. Fix the regulator: <ul style="list-style-type: none"> • Unstick/renew the valves • Set the pressure • Replace the spring 2. Replace diaphragms. 3. Unblock valves and or replace. 4. Replace spray nozzles with appropriate size.
D. Output drops & pump is noisy	<ol style="list-style-type: none"> 1. Blocked suction lines or filter screen. 	<ol style="list-style-type: none"> 1. Check and clean as required.
E. Oil being discharged through delivery line or discoloured oil in sight glass of pump	<ol style="list-style-type: none"> 1. One or more diaphragms split or ruptured. 	<ol style="list-style-type: none"> 1. Immediately drain oil from pump and flush to remove all spray residues from sump. Remove pump heads & fit new diaphragms. Fill to correct level with oil as per pump manual.

SECTION 10

TROUBLESHOOTING

DIAPHRAGM PUMP PROBLEMS

PROBLEM	PROBABLE CAUSE	REMEDY
SUCTION SIDE OF PUMP		
F. Suction hose vibration... / hunting	1. Air getting into suction.	1. Check suction lines for leaks.
G. Pump valves hammering	1. Suction tap partly turned off. 2. Suction strainer(s) blocked.	1. Seal all joints securely with tape or stag. Firm up clamps. 2. Check the suction filter is sealed.
H. No water flow in suction hose	1. Suction Tank Selection Valve turned off. 2. Suction strainer(s) blocked.	1. Turn valve fully on. 2. Clean filters.
DISCHARGE SIDE OF PUMP		
I. Manual regulator valve leaking from spindle	1. Split diaphragm or O-rings.	1. Remove 4 body set screws, replace diaphragm and O-rings.
J. Pressure gauge showing correct working pressure no pressure at nozzle	1. Faulty solenoids. 2. Blocked discharge filter where fitted. 3. Ants, wasps build nests in discharge line or nozzles.	1. Service or replace. 2. Clean discharge filter. 3. Clean nozzles of foreign materials with tooth brush.

SECTION 10

TROUBLESHOOTING

GENERAL SPRAYER PROBLEMS

PROBLEM	PROBABLE CAUSE	REMEDY
1. No spray when turned on	<ol style="list-style-type: none"> 1. Filter on the inlet side of the pump blocked. 2. Faulty pump. 3. Control valves not working 	<ol style="list-style-type: none"> 1. Dismantle, clean & re-assemble. 2. Change pump. 3. Check all motor valves and manual Pressure Regulating Valve.
2. Sprays for short time only	<ol style="list-style-type: none"> 1. Air inlet to tank blocked. 2. Filter on suction side of pump blocking or blocked. 	<ol style="list-style-type: none"> 1. Clean air vent. 2. Dismantle, clean & re-assemble the filter. If filter problem persists, clean out the tank & start again.
3. Spray pattern is uneven	<ol style="list-style-type: none"> 1. Blocked nozzles. 2. Nozzle tips worn. 3. Different pressure at nozzles; wrong nozzles fitted. 	<ol style="list-style-type: none"> 1. Remove, clean & check. Check output & for streaks. 2. Check nozzle output, replace worn nozzles. 3. Remove a nozzle in each section & check that flow rate is the same. If different, check for blockages.
4. Pressure going up - output going down	<ol style="list-style-type: none"> 1. Blocked nozzles. 2. Pressure filter blocking. 	<ol style="list-style-type: none"> 1. Dismantle, clean & refit. Check pressure returns to normal. Check all filters and spray mixture. 2. Check & clean the pressure filter.
5. Pressure falling	<ol style="list-style-type: none"> 1. Filter on suction side blocked. 2. Nozzle tips worn. 3. Pressure gauge faulty. 4. Pump worn. 5. Worn manual PRV (pressure regulating valve) 	<ol style="list-style-type: none"> 1. Dismantle & clean the filter. 2. Check nozzle output, replace worn nozzles. 3. Check with new pressure gauge. 4. Repair or replace the pump. 5. Replace PRV
6. Spray pattern narrow or faltering	<ol style="list-style-type: none"> 1. Pressure too low. 2. Nozzles blocked or partially blocked. 	<ol style="list-style-type: none"> 1. Check that the correct nozzles are being used... check and clean.. 2. Check that the tank is not empty. If not, there is an air leak between the pump & tank or in the pump. Check plumbing & repair.
7. Foam in the tank	<ol style="list-style-type: none"> 1. Too much agitation. 	<ol style="list-style-type: none"> 1. Switch Off one or both agitators.

SECTION 10

TROUBLESHOOTING

MOTOR VALVE PROBLEMS

PROBLEM	PROBABLE CAUSE	REMEDY
1. Section line valve opens when it should be closed and closes when it should be open.	1. Wiring incorrect.	1. Reverse polarity of valve by changing wires at the valve cap.
2. Water leaks past valve when valve is shut.	1. Worn seat.	1. Replace seat/hosetail and/or valve system if necessary.
3. Valve won't operate.	1. No power to valve. 2. Motor failure. 3. Valve clogged.	1. Check all connections, supply - loom. 2. Replace motor. 3. Clean internals of valve and/or put a new valve kit in the valve.
4. Servo valve not regulating flow.	1. Valve jamming. 2. No power. 3. Power clogged.	1. Clean out valve or replace. 2. Check all power leads and supply, or replace motor. 3. Clean out valve and/or put a new valve kit in the valve.
5. Dump valve not releasing pressure in system on shut-off.	1. No power to valve. 2. Valve motor failed. 3. Dump-line blocked.	1. Check power supply and all connections. 2. Check motor and replace if required. 3. Clean valve and return line.

OTHER PROBLEMS

PROBLEM	PROBABLE CAUSE	REMEDY

SECTION 11

ASSEMBLY DRAWINGS, PARTS & SCHEMATICS

HTP3_QMQ18 - 3000 LT 3 ROW QM SMART SPRAYER, 18 X QM-420	80
HTP3_QMQ12 - 3000 LT 2 ROW QM SMART SPRAYER, 12 X QM-420, RECAPTURE	82
HP-319-9 - QM-420 SPRAY FAN ASSEMBLY	84
HP-319-9 - QM-420 DRIVE BODY ASSY	86
HP-219M6.5CE-2 - HYD MOTOR 6.5CC INC SPIDER COUPLER	87
KH-5104L - FAN FRAME ASSY, 3 X QM420	88
KH-5101L - FAN FRAME ASSY, 2 X QM420	89
KH-5115 - SWIVEL ASSY SMART SPRAYER QM-420	90
TOWERS	91
MANIFOLDS	94
RECAPTURE	98
SMART SPRAYER - FUSION SYSTEM SCHEMATIC	99
PLUMBING DIAGRAMS	100
HYDRAULIC SYSTEMS	102

SECTION 11

ASSEMBLY DRAWINGS, PARTS & SCHEMATICS

HTP3_QMQ18 3000 LT 3 ROW QM SMART SPRAYER, 18 X QM-420

Generic assembly for parts illustration purposes. Not all options shown.

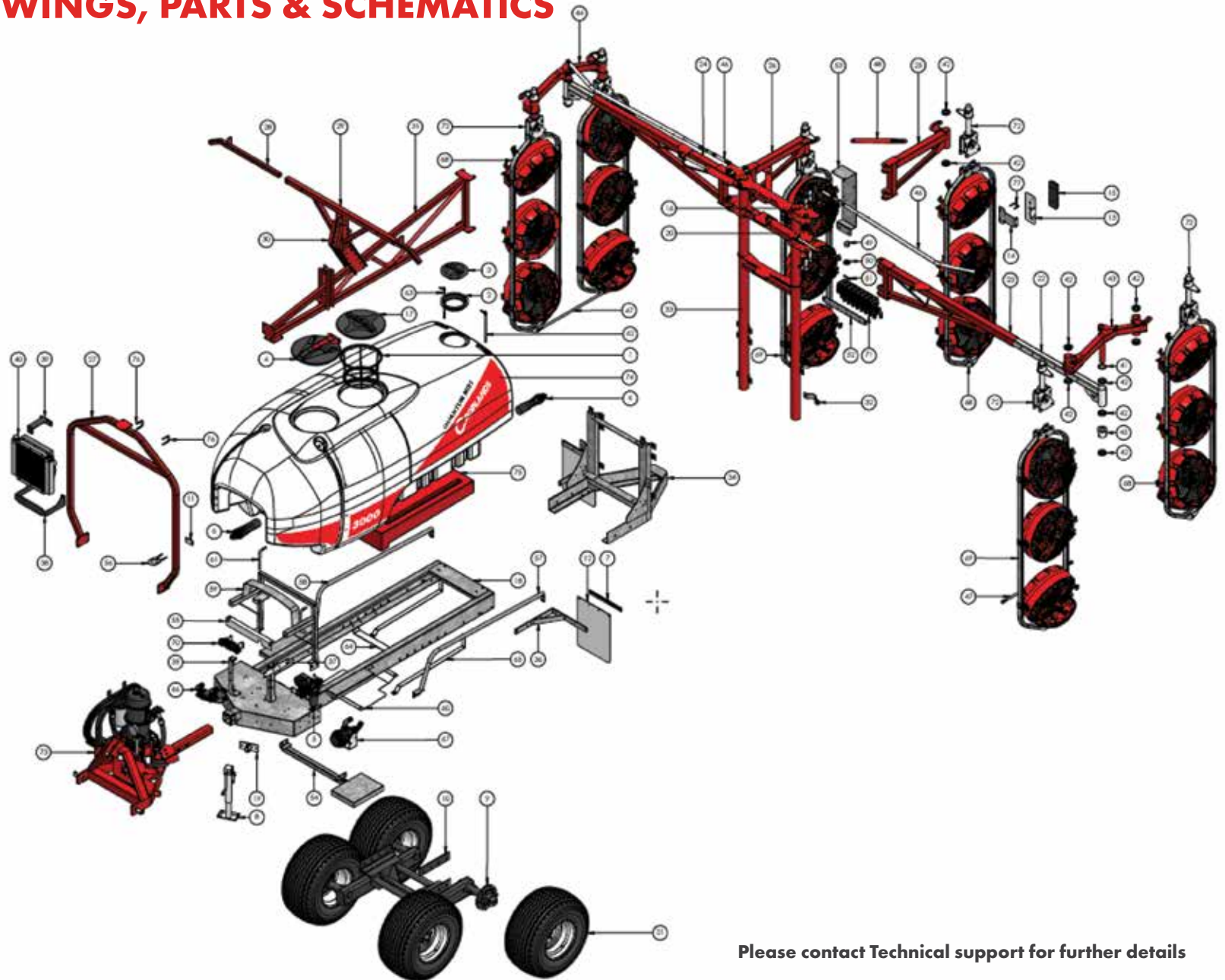

SECTION 11

ASSEMBLY DRAWINGS, PARTS & SCHEMATICS

ITEM NO.	PART NUMBER	DESCRIPTION	
1	A300130	FILTER BASKET LARGE 254MM DEEP	1
2	A350620	LID RING WITH GASKET	1
3	A3522120	LID ONLY 255MM CLOSED	1
4	A356060	LID HINGE 455MM 180DEG	1
5	A463CCRO08A	VALVE ASSEMBLY SERVO DUMP & FILTER	1
6	A502163	AGITATOR	2
7	BP-180	MUDFLAP PLATE	2
8	BP-184A	JOCKEY STAND SHORT PINTO	1
9	BP-400W	WALKING BEAM AXLE 2000/3000	1
10	BP-400W-2	SPACER 10MM BP-400W 2000/3000	2
11	BP-541	PLATE FOR 50MM U-BOLT	1
12	BP-542	MUDFLAP WHITE	2
13	BP-635	MOUNT PLATE TAIL LIGHT	2
14	BP-635-1	TAIL LIGHT EXTENSION BRACKET	2
15	BP-636	LIGHT KIT WITH HARNESS	2
16	BP-700-9AA	PIN 30MM X 155MM HAYLITE	8
17	G8161000	LID/RING KIT 455MM	1
18	HP3000ABA	CHASSIS 3000LT AIRBLAST HAYLITE	1
19	HP-006	SPIGOT PLATE JACK STAND	1
20	HP-016	HYDRAULIC CYLINDER 2.0 X 10	2
21	HP-202GA	WHEEL/TYRE 400X15.5 NO OFFSET	4
	HP-200	WHEEL/TYRE AWT 11.5/80 - 15.3	option
22	HP-274A-2H-1	BOOM ARM EXTENSION QM420	2
23	HP-274A-2HA	BOOM ARM LH QM SMART SPRAY HD	1
24	HP-274A-3HA	BOOM ARM RH QM SMART SPRAY HD	1
25	HP-274A-2i	BOOM ARM LH INNER RECAPTURE	1
26	HP-274A-3i	BOOM ARM RH INNER RECAPTURE	1
27	HP-274A-4B2	FRONT BRACE QM 3000/4000	1
28	HP-274A-5	PARKING ARM	2
29	HP-274A-5-1	PARKING BRACKET QM	1
30	HP-274A-5-2	PARKING BRACKET ADAPTOR	1
31	HP-274A-6G	TOP BRACE QM 3000LT	1
32	HP-274A-14G	CLAMP HALF SADDLE 90MM GALV	6
33	HP-274A-15A2	MAIN TOWER ASSEMBLY SMART SPRAY	1
34	HP-283E2	SUB FRAME QM 3000LT VER 2	1
35	HP-286A	BRACKET ECM 3000 QUANTUM MIST	2
36	HP-288	BRACKET MUDFLAP BP-400D	2
37	HP-289	MANIFOLD BRACKET A463CCRO08A	1
38	HP-298-15A-1	BRACKET OIL COOLER	1

39	HP-298-15A-2	TOP SUPPORT BRACKET OIL COOLER	1
40	HP-298-16A	OIL COOLER 12V AIR TYPE HYDAC	1
41	HP-318-01-4	SWIVEL HEAD TUBE WASHER	2
42	HP-318-02	BUSH BOOM/SWIVEL HEADS	18
43	HP-318-03L	FAN-FAN TWIN HANGER LH	1
44	HP-318-03R	FAN-FAN TWIN HANGER RH	1
45	HP-318-03-1	COLLAR TWIN HANGERS	2
46	HP-318-05	PUSH-PULL ROD MAIN BOOM	2
47	HP-318-06	FAN-FAN LINK ROD	2
48	HP-318-07	INNER ROW ADJUST PLATE	2
49	HP-318-08	POSITION SENSOR	2
50	HP-318-08-1	POSITION SENSOR DISK	2
51	HP-318-08-2	POSITION SENSOR LINK ARM	2
52	HP-318-09	BRACKET SECTION VALVE MOUNT	1
53	HP-318-10	BRACKET FUSION HYDRAULIC MANIFOLD	1
54	HP-402A	RETRACTABLE STEP 2000LT	1
55	HP-432A	BRAGLIA VALVE BRACKET 3000LT	1
56	HP-434	BRACKET DAM FILL 3000LT	1
57	HP-504LA	SIDE RAIL 3000LT LH	1
58	HP-504RA	SIDE RAIL 3000LT RH	1
59	HP-511A	FRONT TANK SUPPORT 3000LT	1
60	HP-512	SUMP GUARD 3000LT	1
61	HP-514	FRONT TIE DOWN ROD 3000LT	2
62	HP-515L	REAR LEFT TIE DOWN ROD 3000LT	1
63	HP-515R	REAR RIGHT TIE DOWN ROD 3000LT LT	1
64	HP-520	CROSS RAIL BRACKET FLUSH TANK	1
65	HP-521	SUPPORT STRAP FLUSH TANK	2
66	HP-947C-2	SUCTION VALVE 1 1/2"	1
67	HP-947C-3	SUCTION FILTER 1 1/2"	1
68	KH-5100L	FAN FRAME 3X420 FANS LH PLUMBING	3
69	KH-5100R	FAN FRAME 3X 420 FANS	3
70	KH-5110	FUSION FLOW METER MANIFOLD T5M	1
71	KH-5112	MANIFOLD T5 8 NEG SECTIONS	1
72	KH-5115	SWIVEL HEAD ASSEMBLY QM420	6
73	KH-6000A	MICRO POWER PACK - REFER MICROPP MANUAL FOR DETAILS	1
74	P3000AB-RAW	4000LT TANK POLY AIRBLAST POLY	1
75	P3000AB-110RAW	FLUSH TANK 110LT 3000LT	1
76	XBMBB50	U-BOLT 50MM X 10	2
77	XBMBB50-50	U BOLT 50MM X 50 X 3/8 THREAD	4

NOTE

Drawings are for illustration purpose only - refer to sprayer for actual plumbing. Parts listed are indicative of the sprayer type.

Items in *italics* or without a part number are non stocked items and may need to be specially ordered.

For further parts information refer to: www.croplands.com.au

Please contact Technical support for further details

SECTION 11

ASSEMBLY DRAWINGS, PARTS & SCHEMATICS

HTP3_QMQ12 3000 LT 2 ROW QM SMART SPRAYER, 12 X QM-420, RECAPTURE

Generic assembly for parts illustration purposes. Not all options shown.

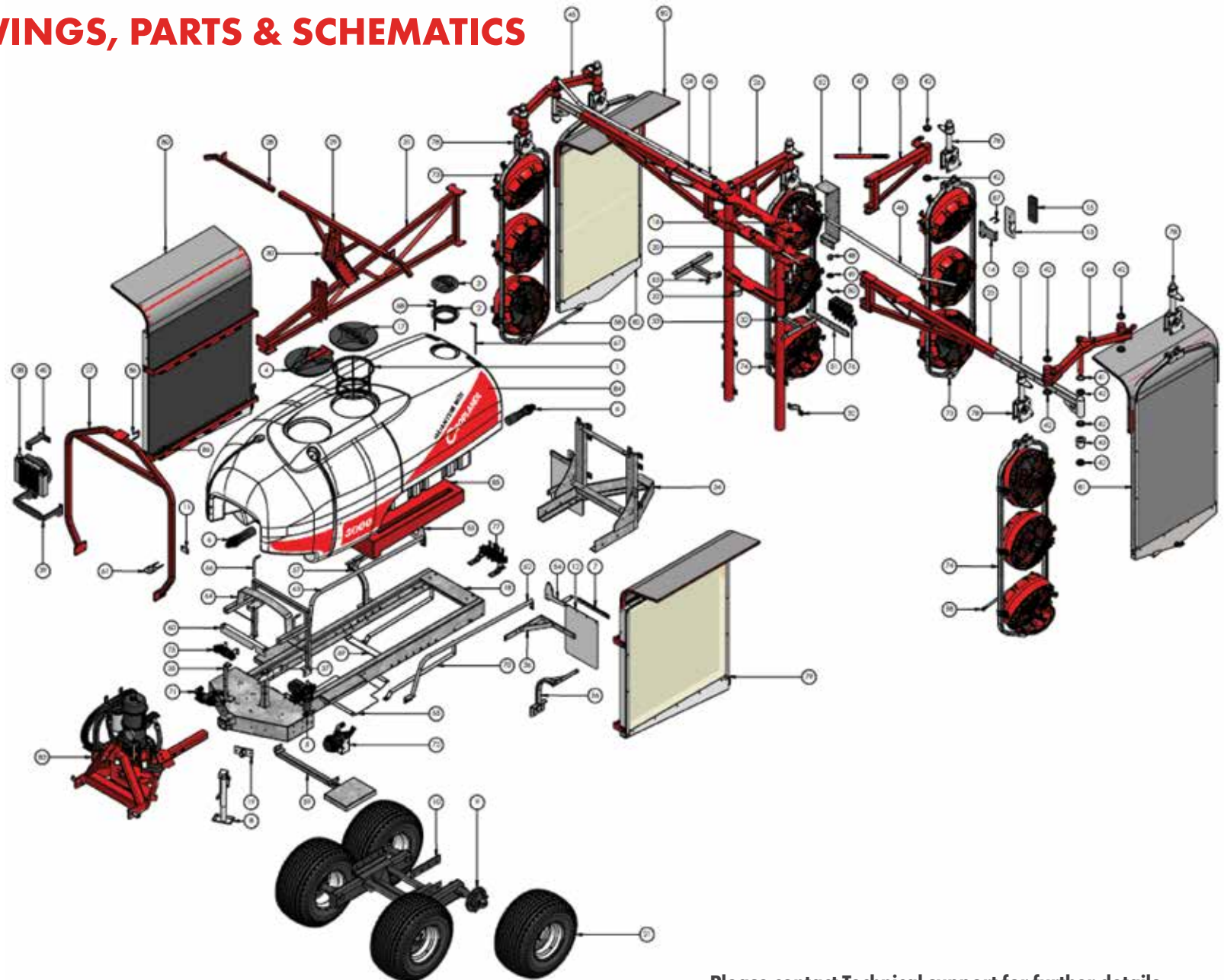

SECTION 11

ASSEMBLY DRAWINGS, PARTS & SCHEMATICS

ITEM NO.	PART NUMBER	DESCRIPTION	
1	A300130	FILTER BASKET LARGE 254MM DEEP	1
2	A350620	LID RING WITH GASKET	1
3	A3522120	LID ONLY 255MM CLOSED	1
4	A356060	LID HINGE 455MM 180DEG	1
5	A463CRO08A	VALVE ASSEMBLY SERVO DUMP & FILTER	1
6	A502163	AGITATOR	2
7	BP-180	MUDFLAP PLATE	2
8	BP-184A	JOCKEY STAND SHORT PINTO	1
9	BP-400W	WALKING BEAM AXLE 2000/3000	1
10	BP-400W-2	SPACER 10MM BP-400W 2000/3000	2
11	BP-541	PLATE FOR 50MM U-BOLT	1
12	BP-542	MUDFLAP WHITE	2
13	BP-635	MOUNT PLATE TAIL LIGHT	2
14	BP-635-1	TAIL LIGHT EXTENSION BRACKET	2
15	BP-636	LIGHT KIT WITH HARNESS	2
16	BP-700-9AA	PIN 30MM X 1.55MM HAYLITE	8
17	G8161000	LID/RING KIT 455MM	1
18	HP3000ABA	CHASSIS 3000LT AIRBLAST HAYLITE	1
19	HP-006	SPRIGOT PLATE JACK STAND	1
20	HP-016	HYDRAULIC CYLINDER 2.0 X 10	2
21	HP-202GA	WHEEL/TYRE 400X15.5 NO OFFSET	4
	HP-200	WHEEL/TYRE AWT 11.5/80 - 15.3	option
22	HP-274A-2H-1	BOOM ARM EXTENSION QM420	2
23	HP-274A-2HA	BOOM ARM LH QM SMART SPRAY HD	1
24	HP-274A-3HA	BOOM ARM RH QM SMART SPRAY HD	1
25	HP-274A-2I	BOOM ARM LH INNER RECAPTURE	1
26	HP-274A-3I	BOOM ARM RH INNER RECAPTURE	1
27	HP-274A-4B2	FRONT BRACE QM 3000/4000	1
28	HP-274A-5	PARKING ARM	2
29	HP-274A-5-1	PARKING BRACKET QM	1
30	HP-274A-5-2	PARKING BRACKET ADAPTOR	1
31	HP-274A-6G	TOP BRACE QM 3000LT	1
32	HP-274A-14G	CLAMP HALF SADDLE 90MM GALV	8
33	HP-274A-15A2	MAIN TOWER ASSEMBLY SMART SPRAY	1
34	HP-283E2	SUB FRAME QM 3000LT VER 2	1
35	HP-286A	BRACKET ECM 3000 QUANTUM MIST	2
36	HP-288	BRACKET MUDFLAP BP-400D	2
37	HP-289	MANIFOLD BRACKET A463CRO08A	1
38	HP-298-15A	OIL COOLER 12V AIR TYPE HYDAC	1
39	HP-298-15A-1	BRACKET OIL COOLER	1
40	HP-298-15A-2	TOP SUPPORT BRACKET OIL COOLER	1
41	HP-318-01-4	SWIVEL HEAD TUBE WASHER	2
42	HP-318-02	BUSH/BOOM/SWIVEL HEADS	18
43	HP-318-03-1	COLLAR TWIN HANGERS	2
44	HP-318-04L	RECAP-FAN TWIN HANGER LH	1

45	HP-318-04R	RECAP-FAN TWIN HANGER RH	1
46	HP-318-05	PUSH-PULL ROD MAIN BOOM	2
47	HP-318-07	INNER ROW ADJUST PLATE	2
48	HP-318-08	POSITION SENSOR	2
49	HP-318-08-1	POSITION SENSOR DISK	2
50	HP-318-08-2	POSITION SENSOR LINK ARM	2
51	HP-318-09	BRACKET SECTION VALVE MOUNT	1
52	HP-318-10	BRACKET FUSION HYDRAULIC MANIFOLD	1
53	HP-325-07-2	RECAPTURE FRAME UPPER MOUNT 2000/3000	2
	HP-325-07-2A	RECAPTURE FRAME UPPER MOUNT 4000LT	option
54	HP-325-07-3L	RECAPTURE FRAME REAR MOUNT LH	1
55	HP-325-07-3R	RECAPTURE FRAME REAR MOUNT RH	1
56	HP-325-07-4L	RECAPTURE FRAME FRONT MOUNT LH 2000/3000	1
	HP-325-07-4LA	RECAPTURE FRAME FRONT MOUNT LH 4000LT	option
57	HP-325-07-4R	RECAPTURE FRAME FRONT MOUNT RH 2000/3000	1
	HP-325-07-4RA	RECAPTURE FRAME FRONT MOUNT RH 4000LT	option
58	HP-325-11	RECAP-FAN LINK ROD	2
59	HP-402A	RETRACTABLE STEP 2000LT	1
60	HP-432A	BRAGLIA VALVE BRACKET 3000LT	1
61	HP-434	BRACKET DAM FILL 3000LT	1
62	HP-504LA	SIDE RAIL 3000LT LH	1
63	HP-504RA	SIDE RAIL 3000LT RH	1
64	HP-511A	FRONT TANK SUPPORT 3000LT	1
65	HP-512	SUMP GUARD 3000LT	1
66	HP-514	FRONT TIE DOWN ROD 3000LT	2
67	HP-515L	REAR LEFT TIE DOWN ROD 3000LT	1
68	HP-515R	REAR RIGHT TIE DOWN ROD 3000LT	1
69	HP-520	CROSS RAIL BRACKET FLUSH TANK	1
70	HP-521	SUPPORT STRAP FLUSH TANK	2
71	HP-947C-2	SUCTION VALVE 1 1/2"	1
72	HP-947C-3	SUCTION VALVE 1 1/2"	1
73	KH-5100L	FAN FRAME 3X420 FANS LH PLUMBING	2
74	KH-5100R	FAN FRAME 3X 420 FANS	2
75	KH-5110	FUSION FLOW METER MANIFOLD TSM	1
76	KH-5111	MANIFOLD TS 4 NEG SECTIONS	1
77	KH-5114	MANUAL TAPS X 4 FOR RECAPTURE	1
78	KH-5115	SWIVEL HEAD ASSEMBLY QM420	6
79	KH-5116L	LEFT HAND INNER RECAPTURE ASSEMBLY	1
80	KH-5116R	RIGHT HAND INNER RECAPTURE ASSEMBLY	1
81	KH-5117L	LEFT HAND OUTER RECAPTURE ASSEMBLY	1
82	KH-5117R	RIGHT HAND OUTER RECAPTURE ASSEMBLY	1
83	KH-600A	MICRO POWER PACK - REFER MICROPP MANUAL FOR DETAILS	1
84	P3000AB-RAW	4000LT TANK POLY AIRBLAST POLY	1
85	P3000AB-110RAW	FLUSH TANK 110LT 3000LT	1
86	XBMB850	U-BOLT 50MM X 10	2
87	XBMB850-50	U BOLT 50MM X 50 X 3/8 THREAD	4

NOTE

Drawings are for illustration purpose only - refer to sprayer for actual plumbing. Parts listed are indicative of the sprayer type.

Items in *italics* or without a part number are non stocked items and may need to be specially ordered.

For further parts information refer to: www.croplands.com.au

Please contact Technical support for further details

SECTION 11

ASSEMBLY DRAWINGS, PARTS & SCHEMATICS

HP-319-31 QM-420 SPRAY FAN ASSEMBLY

Using 6.5cc hydraulic motor. 9.8cc hydraulic motor is an option.

PAT.PEND.

PATENT PENDING

QM-420

XD-195

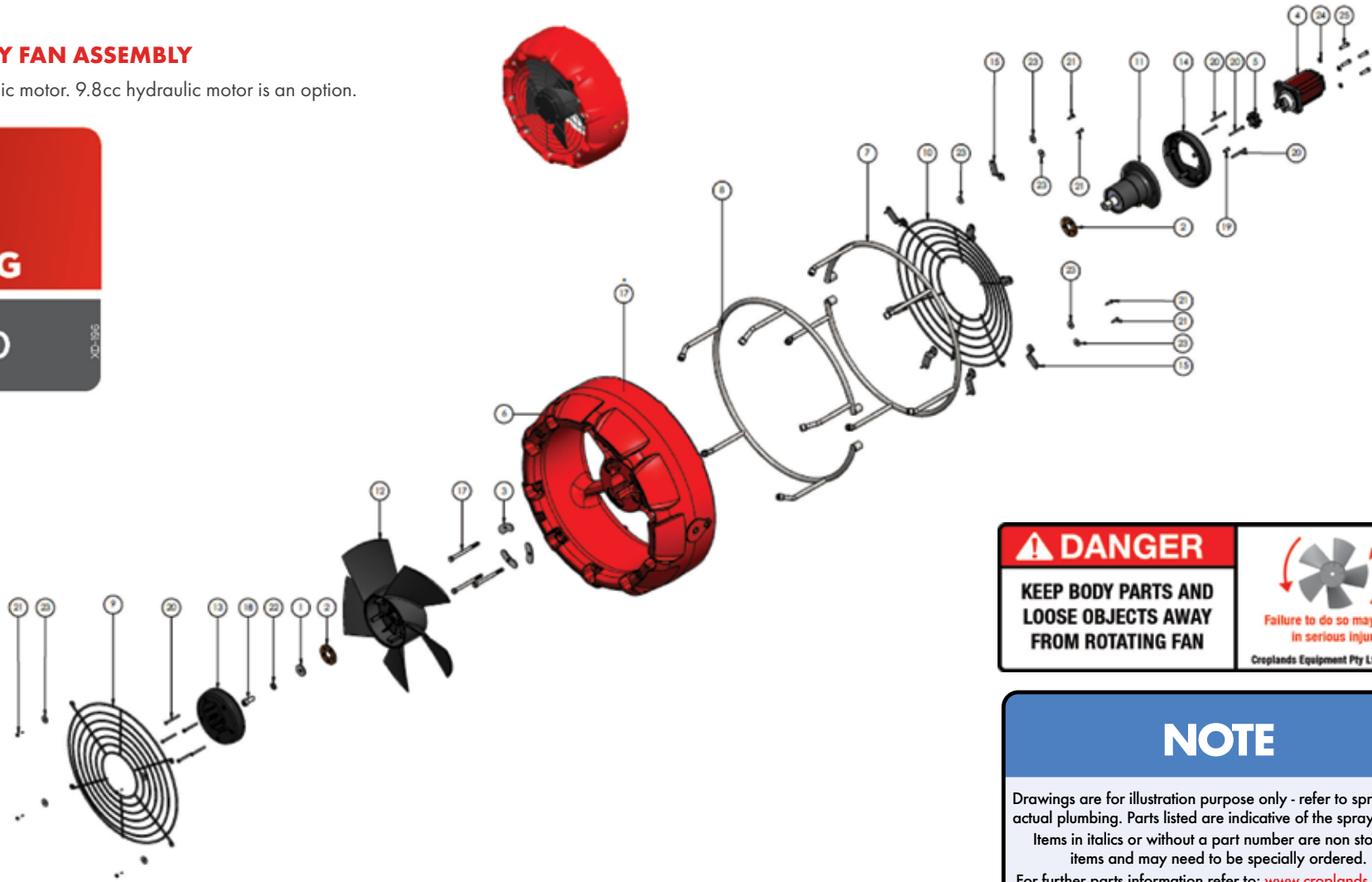

⚠ DANGER	 <p style="color: red; font-size: small;">Failure to do so may result in serious injury.</p>
KEEP BODY PARTS AND LOOSE OBJECTS AWAY FROM ROTATING FAN	
Croplands Equipment Pty Ltd XD-195	

NOTE
<p>Drawings are for illustration purpose only - refer to sprayer for actual plumbing. Parts listed are indicative of the sprayer type.</p> <p>Items in <i>italics</i> or without a part number are non stocked items and may need to be specially ordered.</p> <p>For further parts information refer to: www.croplands.com.au</p>

Please contact Technical support for further details

SECTION 11

ASSEMBLY DRAWINGS, PARTS & SCHEMATICS

ITEM NO.	PART NUMBER	DESCRIPTION	
1	HP-119-20	WASHER 10X30 STAINLESS STEEL	1
2	HP-119-23	HEP WASHER 5PIN X 2.4	2
3	HP-219-18	WASHER KIDNEY SHAPED S/S	3
4	HP-219M6.5CE-2	HYDRAULIC MOTOR KIT ASSEMBLY 6.5CC	1
5	HP-219-1C	COUPLING INSERT SUIT CH48	1
6	HP-319-3	COWL QM420	1
7	HP-319-5S	SPRAY RING QM420 INNER	1
8	HP-319-5L	SPRAY RING QM420 OUTER	1
9	HP-319-6	GUARD FRONT QM420	1
10	HP-319-7	GUARD REAR QM420	1
11	HP-319-9	MAIN DRIVE BODY ASSEMBLY SERIES 2 HYD	1
12	HP-319-10	FAN PROPELLER QM420	1
13	HP-319-15	COVER FRONT QM420 FAN	1
14	HP-319-15R	COVER REAR QM420 DRIVE BODY	1
15	HP-319-27	CLAMP QM420 GUARD AND RING	8
16	XD-195	LABEL FAN DANGER	1
17	M8X100SSBOLT	M8 X 100 S/S BOLT	3
18	M10X25SHSCREW	M10 X 25 ALLEN HEAD SCREW HT ZP	1
19	M5X1.5SSSCREW	M5 X 1.5 S/S SCREW	1
20	M4X50SSSCREW	M4 X 50 S/S SCREW	9
21	M4.2X19SSSCREW	M4.2 X 19 S/S SCREW	20
22	M10SWASHER	M10 SPRING WASHER ZP	1
23	M4SSFASHER	M4 FLAT WASHER S/S	24
24	M6SSSWASHER	M6 SPRING WASHER SS	4
25	M6X25SSSCREW	M6 X 25 HEX HEAD S/S SCREW	4

Please contact Technical support for further details

SECTION 11

ASSEMBLY DRAWINGS, PARTS & SCHEMATICS

HP-319-9

QM-420 DRIVE BODY ASSY

Can also be used for QM-380, replacing HP-219-9 to 9D.

Note this Drive Body is sold as a stand-alone assembly and hence many of the parts are not stocked (bearings & circlips easily obtained from local bearing shop).

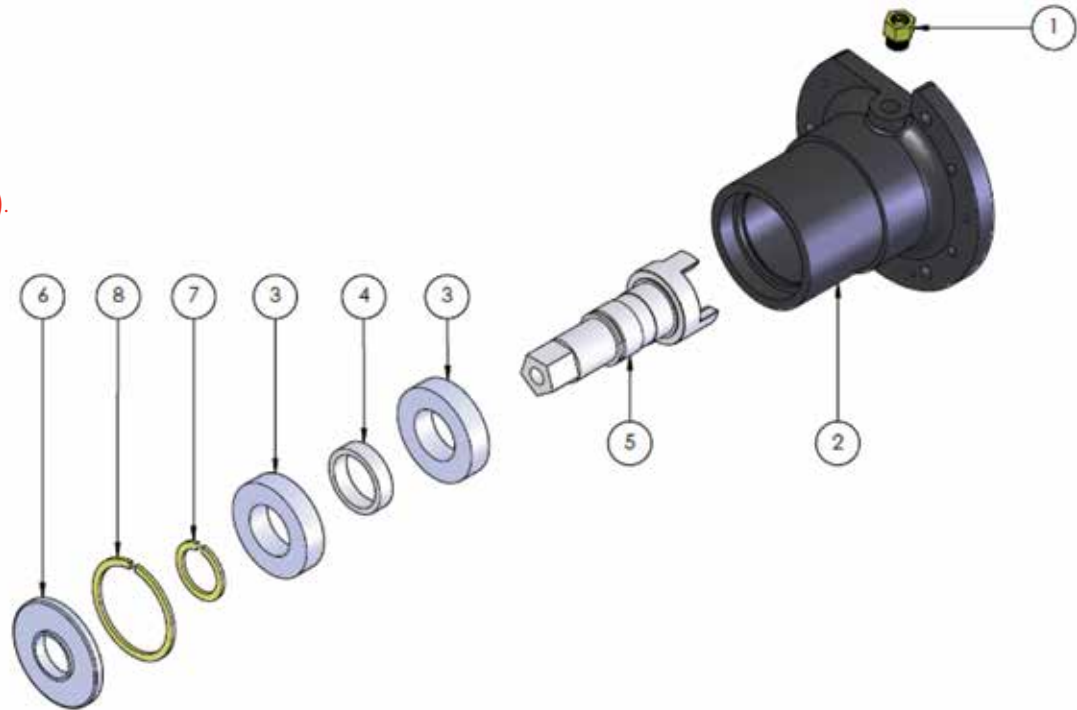

NOTE

Drawings are for illustration purpose only - refer to sprayer for actual plumbing. Parts listed are indicative of the sprayer type.

Items in italics or without a part number are non stocked items and may need to be specially ordered.

For further parts information refer to: www.croplands.com.au

ITEM NO.	PART NUMBER	DESCRIPTION	QTY.
1	HP-048	ADAPTOR BRASS M12 X 1M-1/8" F	1
2	<i>HP-119-9-X4</i>	<i>DRIVE BODY CASTING QM380/QM420</i>	1
3	<i>HP-119-9-1</i>	<i>BEARING 6006 SKF 2RS</i>	2
4	<i>HP-119-9-2</i>	<i>BEARING SPACER</i>	1
5	<i>HP-119-9-5B</i>	<i>SHAFT QM380 HYD DRIVE</i>	1
6	<i>HP-119-14A</i>	<i>Z SEAL Z305F SS304 ASSEMBLY</i>	1
7	<i>CIRCLIP34</i>	<i>CIRCLIP 2MM THK</i>	1
8	<i>CIRCLIP59</i>	<i>CIRCLIP 2MM THK</i>	1

NOTE

See page 74 re the fan rpm sensor tool kit.

SECTION 11

ASSEMBLY DRAWINGS, PARTS & SCHEMATICS

HP-219M6.5CE-2

HYD MOTOR 6.5CC INC SPIDER COUPLER

Very similar to the 9.8cc version, the only variation being the length of the red motor body, 60mm for 6.5cc.

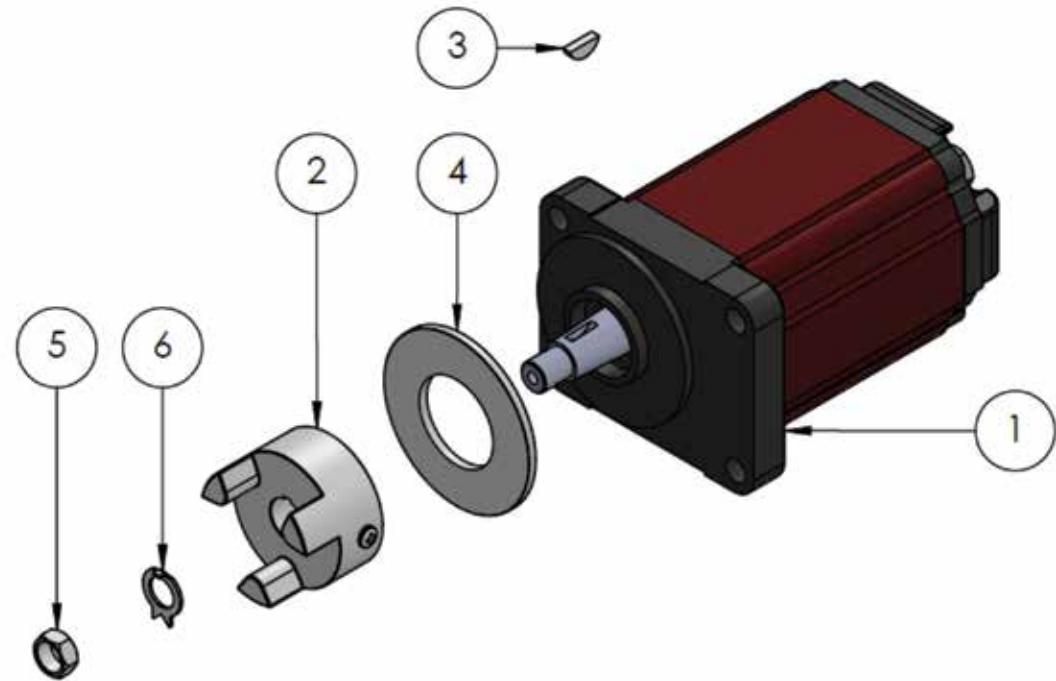

NOTE

Drawings are for illustration purpose only - refer to sprayer for actual plumbing. Parts listed are indicative of the sprayer type.

Items in italics or without a part number are non stocked items and may need to be specially ordered.

For further parts information refer to: www.croplands.com.au

ITEM NO.	PART NUMBER	DESCRIPTION	QTY.
1	HP-219M6.5CE	HYDRAULIC MOTOR 6.5CC GRP 1.5	1
2	HP-219-1A1	COUPLING HALF GROUP 1.5 TAPER	1
3	HP-219-1D1	WOODRUFF KEY	1
4	HP-219-4A	ALUMINIUM LOCATING RING 30MM	1
5	<i>M10FHHNUT</i>	<i>M10 FINE HALF HEX NUT</i>	1
6	<i>M10STARWASHER</i>	<i>M10 STAR WASHER</i>	1

Please contact Technical support for further details

SECTION 11

ASSEMBLY DRAWINGS, PARTS & SCHEMATICS

KH-5104L FAN FRAME ASSY, 3 X QM420

Left Hand Plumbing

NOTE

Drawings are for illustration purpose only - refer to sprayer for actual plumbing. Parts listed are indicative of the sprayer type.

Items in *italics* or without a part number are non stocked items and may need to be specially ordered.

For further parts information refer to: www.croplands.com.au

ITEM 8

New part number, HP-322-05 - the Fan frame is now 1 piece.

ITEM NO.	PART NUMBER	DESCRIPTION	QTY.
1	BALL14MF2M	BALL VALVE 1/4" M/F	6
2	HP-040	NIPPLE 3/8" BSPPM X 3/4" JICM	6
3	HP-042	ELBOW 3/4" JICM X 3/4" JICFM	6
4	HP-045	ELBOW 1/4" BSPPM X 7/16" JICM	3
5	HP-089	TEE 7/16" JICM/JICM/JICFM	3
6	HP-319-31	QM420 NO NOZZLES	3
7	HP-319-3-1	LEAF GUARD QM420	1
8	HP-322-01	FAN FRAME HALF QM420 2200MM	2
9	HP-324-420	CLAMP QM420 FRAME	6
10	TFAD1238FM	ADAPTOR 1/2" BSPF X 3/8" BSPPM	6
11	TFA1412F	TAIL BRASS 1/4" BSPF X 1/2" TAIL	6
12	TFEL1234	ELBOW 1/2" BSPM X 3/4" TAIL	6
13	TFEL1438MM	ELBOW 1/4" BSPM X 3/8" BSPM	6
14	M12X90BOLT	M12 X 90 BOLT HT ZP	2
15	M12X20	M12 X 20 HEX HEAD SET SCREW HT ZP	12
16	M12FWASHER	M12 FLAT WASHER ZP	16
17	M12NNUT	M12 NYLOC NUT HT ZP	2
18	M12SWASHER	M12 SPRING WASHER ZP	12

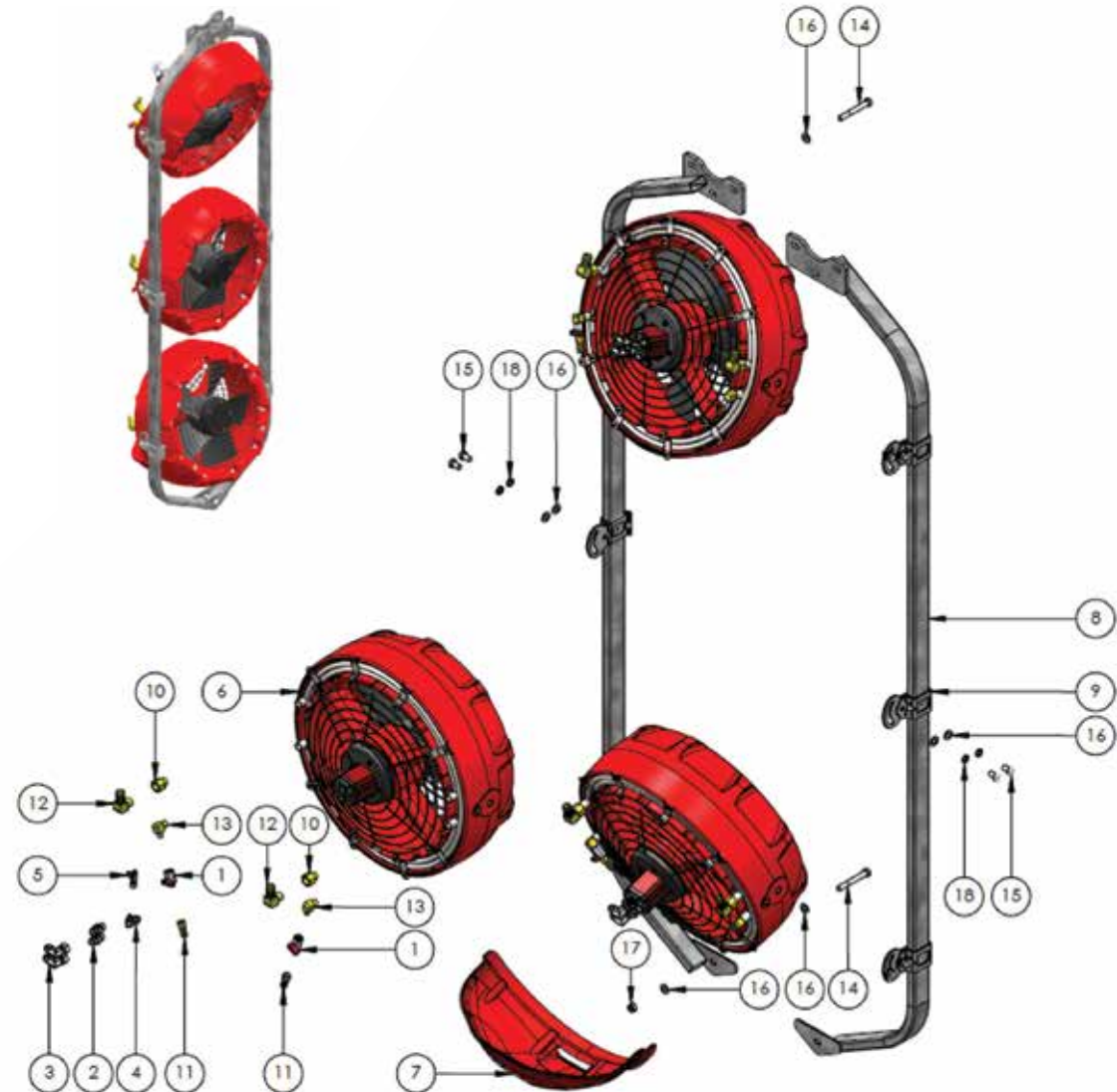

Please contact Technical support for further details

SECTION 11

ASSEMBLY DRAWINGS, PARTS & SCHEMATICS

KH-5105L FAN FRAME ASSY, 2 X QM420

Left Hand plumbing

NOTE

Drawings are for illustration purpose only - refer to sprayer for actual plumbing. Parts listed are indicative of the sprayer type.

Items in italics or without a part number are non stocked items and may need to be specially ordered.

For further parts information refer to: www.croplands.com.au

ITEM 8

New part number, HP-322-05 - the Fan frame is now 1 piece.

ITEM NO.	PART NUMBER	DESCRIPTION	
1	BALL14MF2M	BALL VALVE 1/4" M/F	4
2	HP-040	NIPPLE 3/8" BSPPM X 3/4" JICM	4
3	HP-042	ELBOW 3/4" JICM X 3/4" JICFM	4
4	HP-045	ELBOW 1/4" BSPPM X 7/16" JICM	2
5	HP-089	TEE 7/16" JICM/JICM/JICFM	2
6	HP-319-31	QM420 NO NOZZLES	2
7	HP-319-3-1	LEAF GUARD QM420	1
8	HP-322-01	FAN FRAME HALF QM420 2200MM	2
9	HP-324-420	CLAMP QM420 FRAME	4
10	TFAD1238FM	ADAPTOR 1/2" BSPF X 3/8" BSPM	4
11	TFA1412F	TAIL BRASS 1/4" BSPF X 1/2" TAIL	4
12	TFEL1234	ELBOW 1/2" BSPM X 3/4" TAIL	4
13	TFEL1438MM	ELBOW 1/4" BSPM X 3/8" BSPM	4
14	M12X90BOLT	M12 X 90 BOLT HT ZP	2
15	M12X20	M12 X 20 HEX HEAD SET SCREW HT ZP	8
16	M12FWASHER	M12 FLAT WASHER ZP	12
17	M12NNUT	M12 NYLOC NUT HT ZP	2
18	M12SWASHER	M12 SPRING WASHER ZP	8

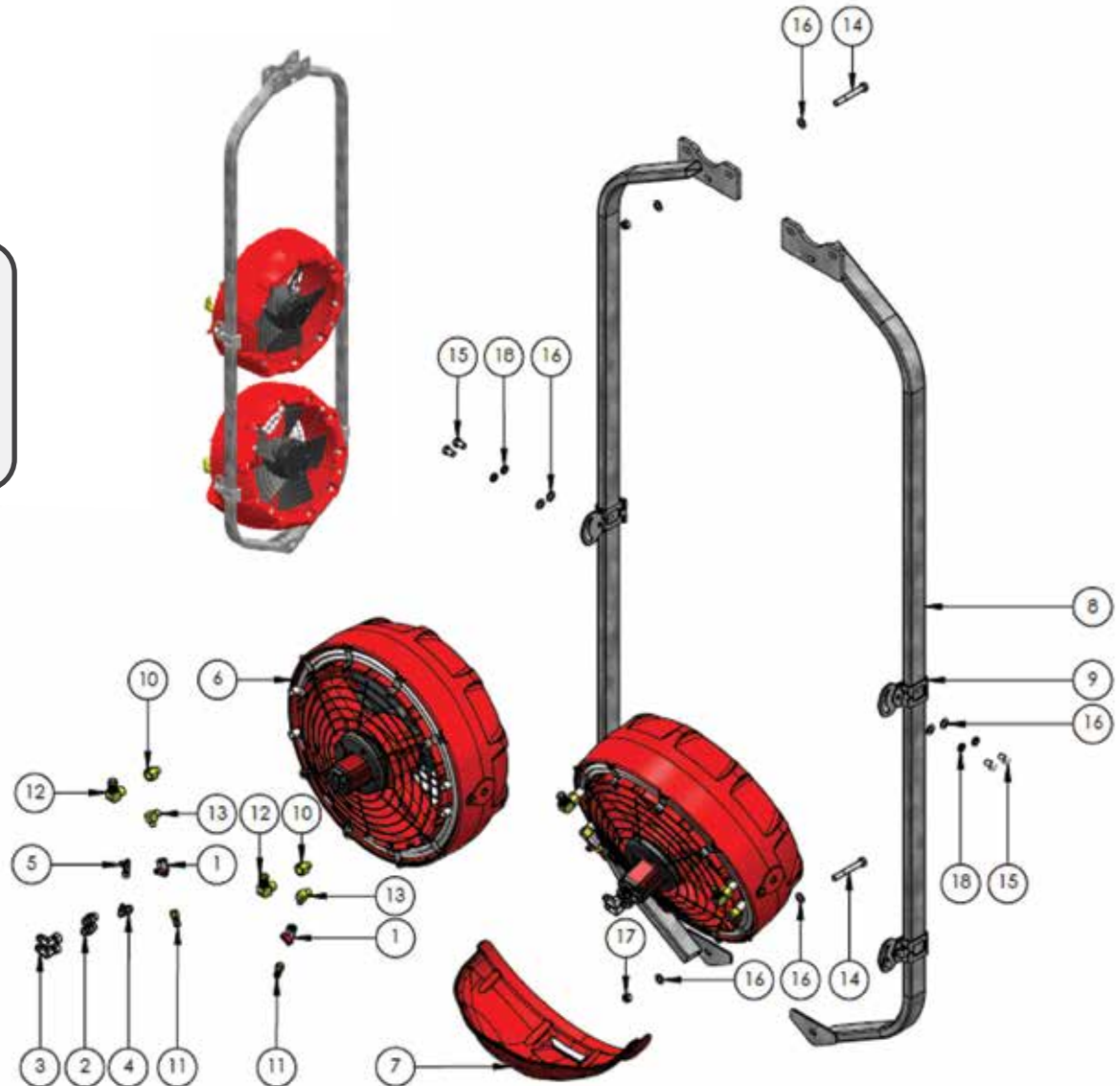

Please contact Technical support for further details

SECTION 11

ASSEMBLY DRAWINGS, PARTS & SCHEMATICS

KH-5115 SWIVEL ASSY SMART SPRAYER QM-420

Fan Frame not shown – Frame connects to items no. 4 & 5
In this example shown connected to Dual Hanger.

NOTE

Drawings are for illustration purpose only - refer to sprayer for actual plumbing. Parts listed are indicative of the sprayer type.
Items in italics or without a part number are non stocked items and may need to be specially ordered.
For further parts information refer to: www.croplands.com.au

ITEM NO.	PART NUMBER	DESCRIPTION	QTY.
1	HP-318-01	SWIVEL HEAD	1
2	HP-318-01-1	SWIVEL HEAD BUSH	1
3	HP-318-01-2	SWIVEL HEAD WASHER	2
4	HP-318-01-3L	SWIVEL HEAD PLATE LH	1
5	HP-318-01-3R	SWIVEL HEAD PLATE RH	1
6	HP-318-01-4	SWIVEL HEAD TUBE WASHER	1
7	HP-318-01-5	SWIVEL HEAD POSITION COLLAR	1
8	HP-318-02	BUSH BOOM/SWIVEL HEADS	1
9	<i>M20 x 140BOLT</i>	<i>M16 X 140 HEX HEAD BOLT HT ZP</i>	1
10	<i>M16FWASHER</i>	<i>M16 FLAT WASHER ZP</i>	2
11	<i>M16NNUT</i>	<i>M16 NYLOC NUT HT ZP</i>	1
12	<i>M12X100BOLT</i>	<i>M12 X 100 HEX HEAD BOLT HT ZP</i>	1
13	<i>M12FWASHER</i>	<i>M12 FLAT WASHER ZP</i>	2
14	<i>M12NNUT</i>	<i>M12 NYLOC NUT HT ZP</i>	1

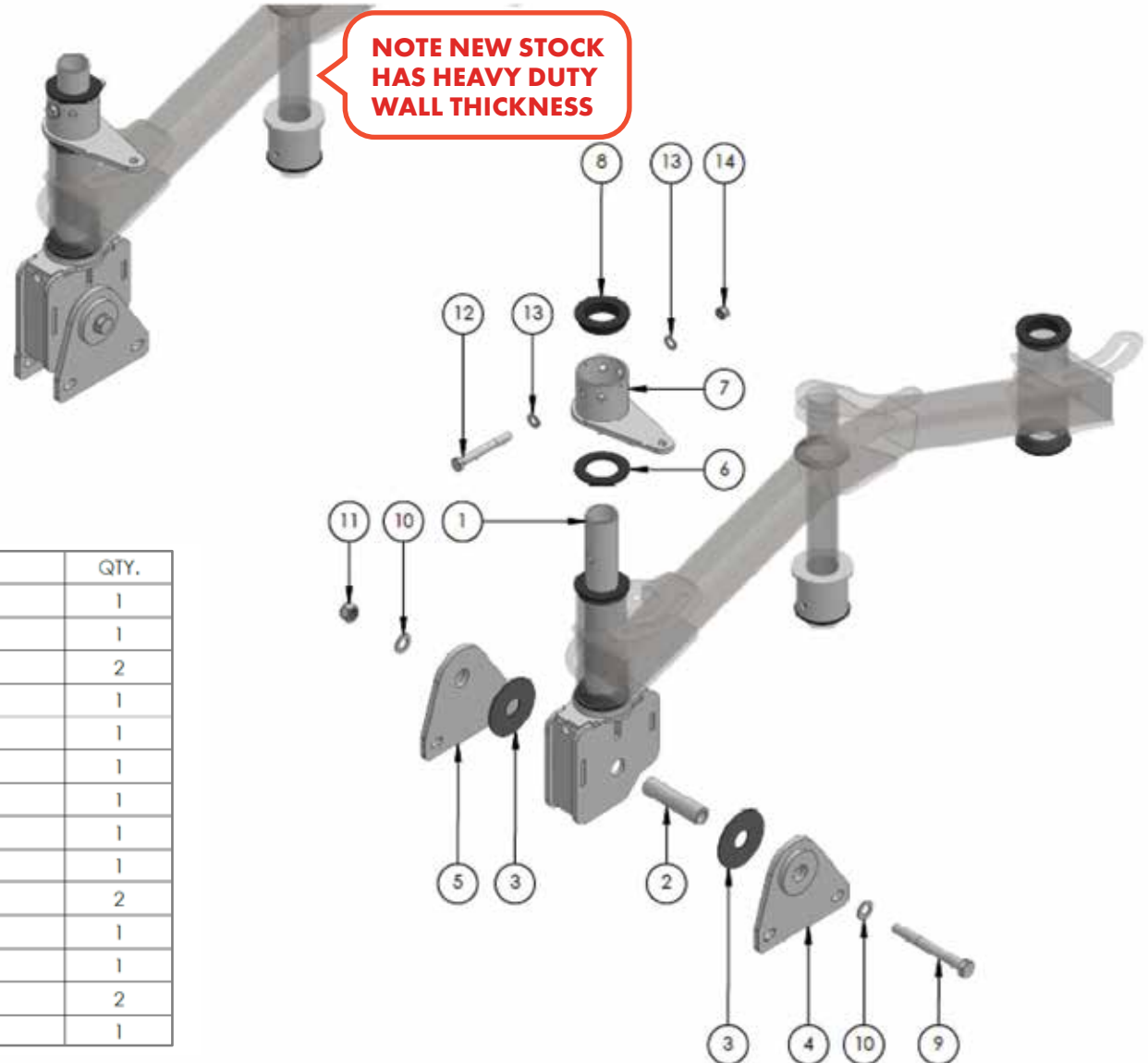

Please contact Technical support for further details

SECTION 11

ASSEMBLY DRAWINGS, PARTS & SCHEMATICS

HP-274A-15A2W

MAIN TOWER QM SMART SPRAYER WIDE

This is the WIDE Smart Sprayer Tower, standard versions are also available.

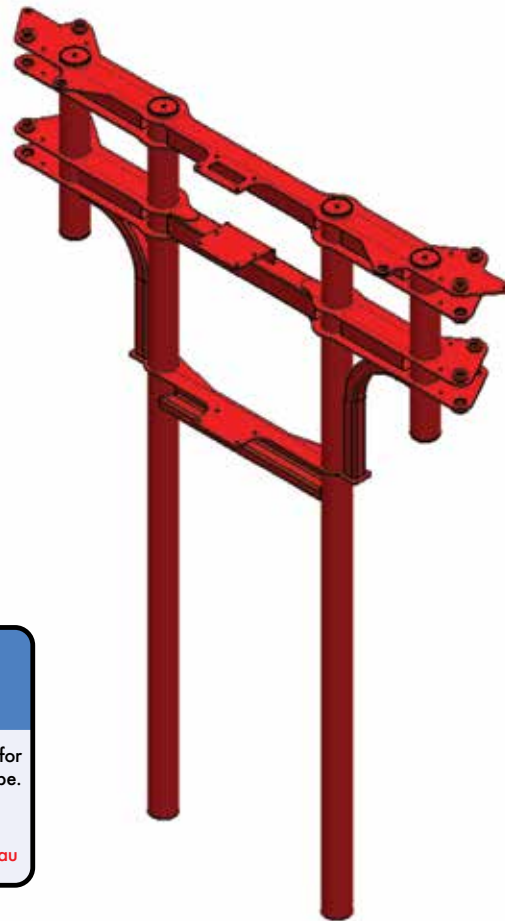

HP-274A-15A2

MAIN TOWER QM SMART SPRAYER

This is the standard Smart Sprayer tower, wide and high versions are also available.



NOTE

Drawings are for illustration purpose only - refer to sprayer for actual plumbing. Parts listed are indicative of the sprayer type.

Items in *italics* or without a part number are non stocked items and may need to be specially ordered.

For further parts information refer to: www.croplands.com.au

Please contact Technical support for further details

SECTION 11

ASSEMBLY DRAWINGS, PARTS & SCHEMATICS

HP-274F TOWER TERRACING ASSY SMART SPRAYER

Wide version of the terracing tower is HP-274G
Note the hydraulic cylinders are for illustration purposes only.

NOTE

Drawings are for illustration purpose only - refer to sprayer for actual plumbing. Parts listed are indicative of the sprayer type.

Items in *italics* or without a part number are non stocked items and may need to be specially ordered.

For further parts information refer to: www.croplands.com.au

ITEM NO.	PART NUMBER	DESCRIPTION	QTY.
1	HP-274B-7A	TOP BRACKET TERRACE	1
2	HP-274B-10	WEAR PAD 75 X 50 X 10MM	4
3	HP-274B-16BL-1	WEAR PAD 75 X 100 X 8	16
4	HP-274F-1	TOWER TERRACE QM SMART SPRAY	1
5	HP-274F-2	CENTRE TOWER POST TERRACE QM SMART SPRAY	1
6	HP-274F-3L	BOOM SLIDE LH TERRACE QM SMART SPRAY	1
7	HP-274F-3R	BOOM SLIDE RH TERRACE QM SMART SPRAY	1
8	M12X100BOLT	M12 X 100 HEX HEAD BOLT HT ZP	2
9	M12X40	M12 X 40 HEX HEAD SET SCREW HT ZP	8
10	M12FWASHER	M12 FLAT WASHER ZP	20
11	M12NNUT	M12 NYLOC NUT HT ZP	10
12	M6X20C/S SCREW	M6X20 C/S HEAD SCREW	40
13	M6FWASHER	M6 FLAT WASHER ZP	40
14	M6NNUT	M6 NYLOC NUT HT ZP	40
15	HP-298-6	HYDRAULIC CYLINDER 2.5 X 24	1
16	HP-298-6	HYDRAULIC CYLINDER 2.5 X 24	1

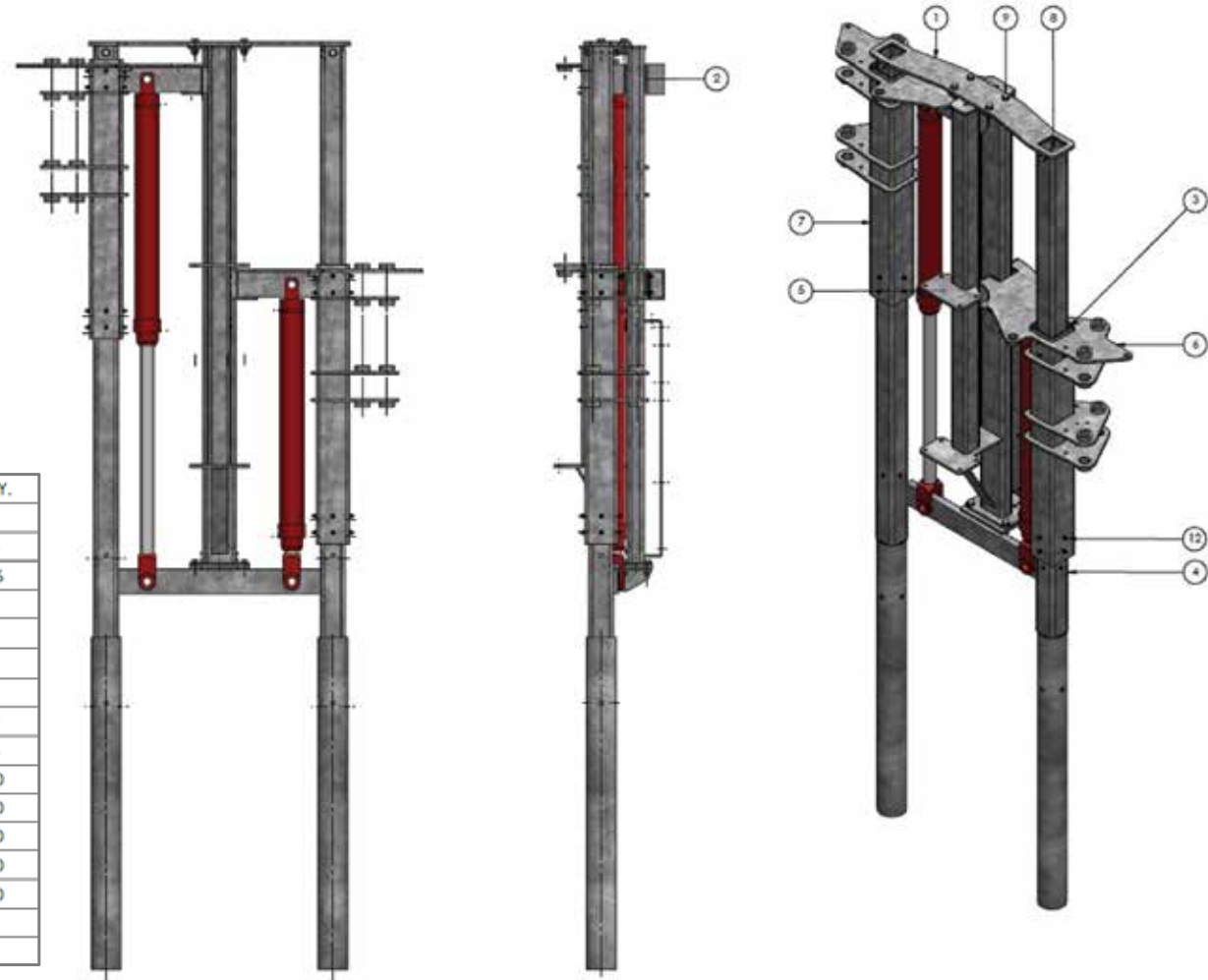

Please contact Technical support for further details

SECTION 11

ASSEMBLY DRAWINGS, PARTS & SCHEMATICS

HP-274G TOWER TERRACING WIDE ASSY SMART SPRAYER

Standard version of the terracing tower is HP-274F.

Note the hydraulic cylinders are for illustration purposes only.

NOTE

Drawings are for illustration purpose only - refer to sprayer for actual plumbing. Parts listed are indicative of the sprayer type.

Items in *italics* or without a part number are non stocked items and may need to be specially ordered.

For further parts information refer to: www.croplands.com.au

ITEM NO.	PART NUMBER	DESCRIPTION	QTY.
1	HP-274B-7A	TOP BRACKET TERRACE	1
2	HP-274B-10	WEAR PAD 75 X 50 X 10MM	4
3	HP-274B-16BL-1	WEAR PAD 75 X 100 X 8	16
4	HP-274F-1	TOWER TERRACE QM SMART SPRAY	1
5	HP-274F-2	CENTRE TOWER POST TERRACE QM SMART SPRAY	1
6	HP-274G-3L	BOOM SLIDE LH TERRACE QM SMART SPRAY	1
7	HP-274G-3R	BOOM SLIDE RH TERRACE QM SMART SPRAY	1
8	M12X100BOLT	M12 X 100 HEX HEAD BOLT HT ZP	2
9	M12X40	M12 X 40 HEX HEAD SET SCREW HT ZP	8
10	M12FWASHER	M12 FLAT WASHER ZP	20
11	M12NNUT	M12 NYLOC NUT HT ZP	10
12	M6X20CSSCREW	M6X20 C/S HEAD SCREW	40
13	M6FWASHER	M6 FLAT WASHER ZP	40
14	M6NNUT	M6 NYLOC NUT HT ZP	40
15	HP-298-6	HYDRAULIC CYLINDER 2.5 X 24	1
16	HP-298-6	HYDRAULIC CYLINDER 2.5 X 24	1

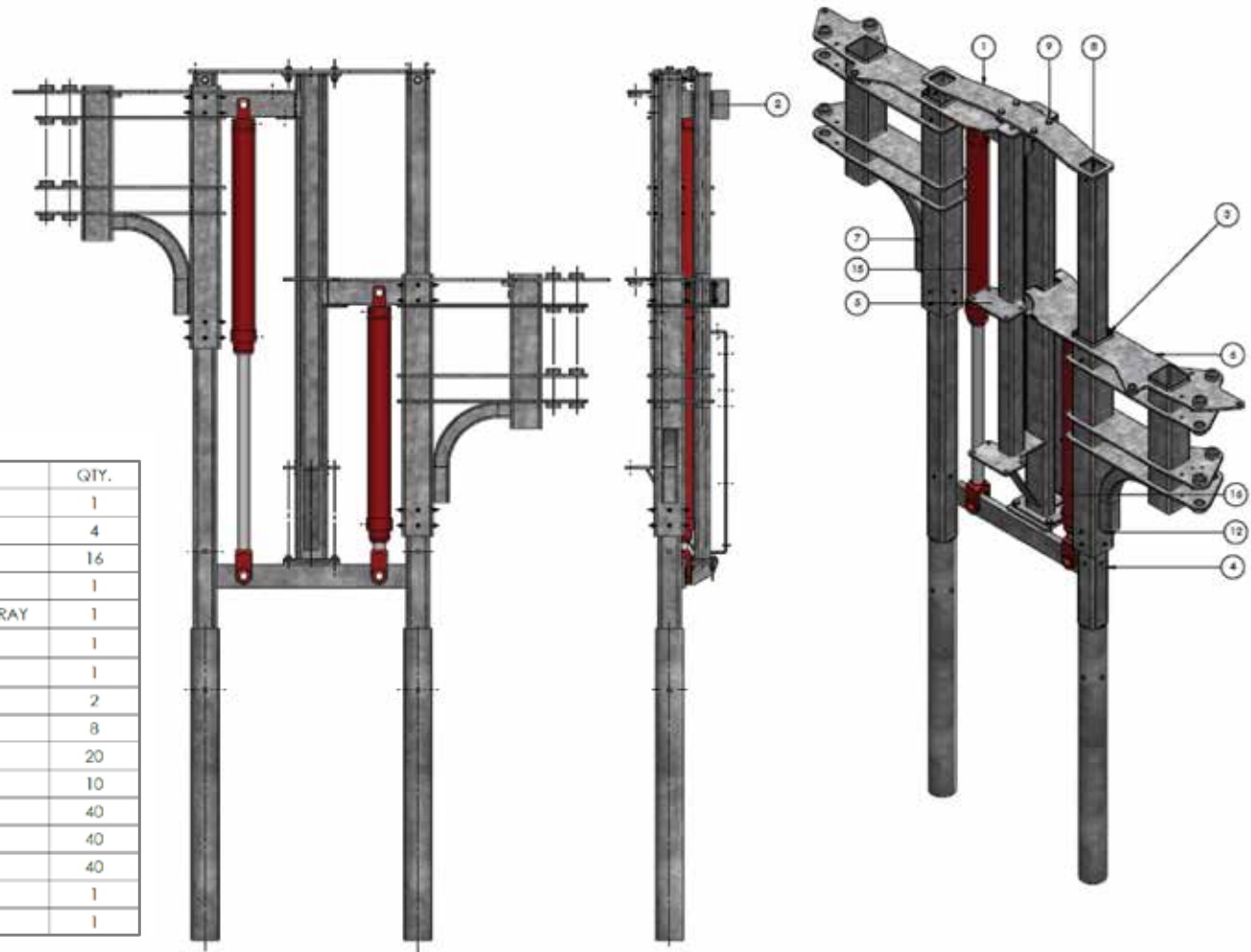

Please contact Technical support for further details

SECTION 11

ASSEMBLY DRAWINGS, PARTS & SCHEMATICS

KH-5100 FUSION FLOW METER MANIFOLD T5M

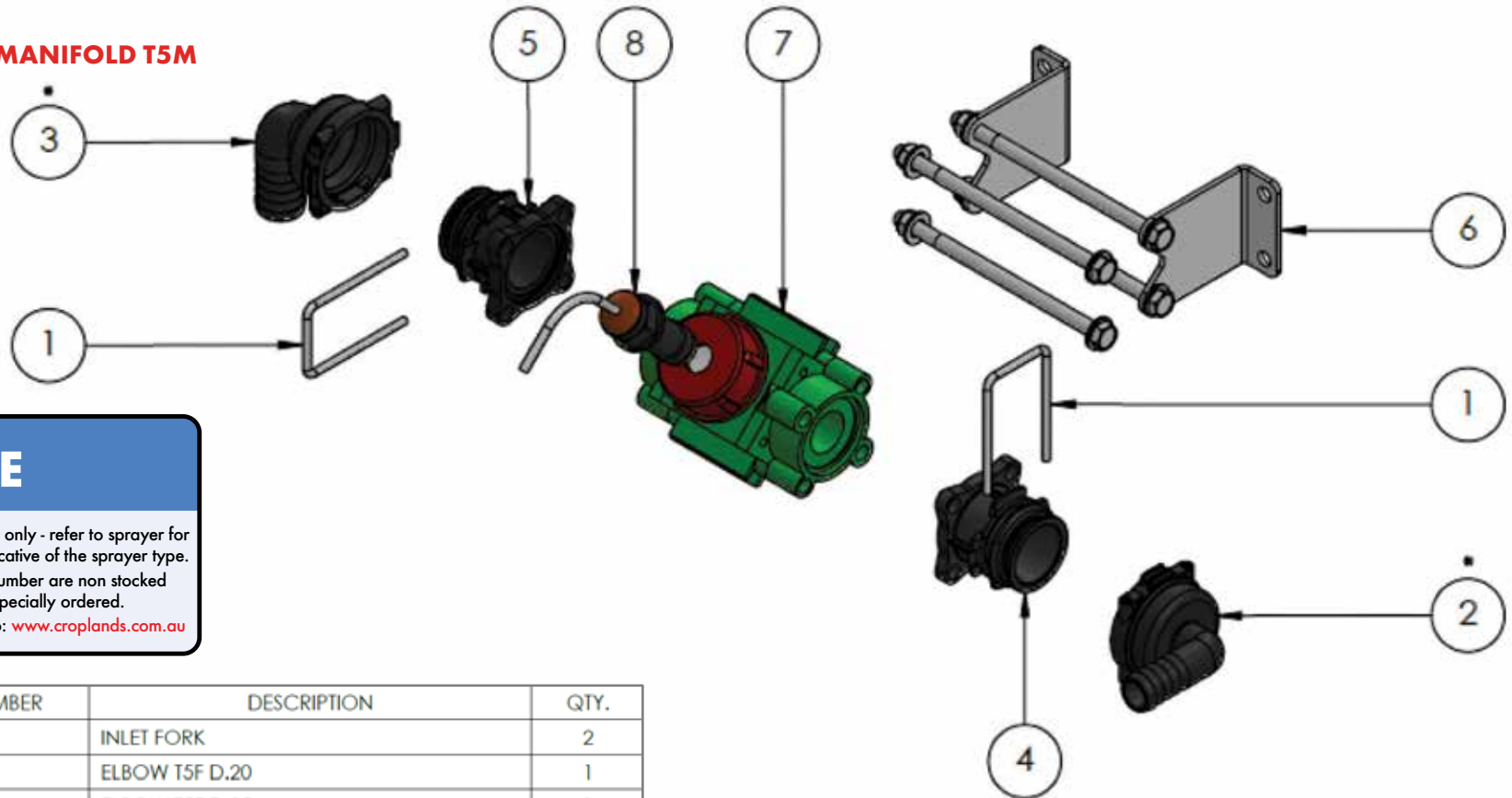

NOTE

Drawings are for illustration purpose only - refer to sprayer for actual plumbing. Parts listed are indicative of the sprayer type.

Items in *italics* or without a part number are non stocked items and may need to be specially ordered.

For further parts information refer to: www.croplands.com.au

ITEM NO.	PART NUMBER	DESCRIPTION	QTY.
1	A010005	INLET FORK	2
2	A1190520	ELBOW T5F D.20	1
3	A1190525	ELBOW T5F D.25	1
4	A463000.056	ADAPTER M TYPE FOR VALVE SERIES 463 T5M	1
5	A463000.156	ADAPTOR T5M FOR VALVES 463 SERIES	1
6	A463000.920	MOUNTING KIT 2 VALVE	1
7	POL00375908A	FLOW METER R/CHECK ZAFF ARAGFL	1
8	POL413003AL.AK	FLOW METER R/CHECK ZAFF ARAGFL	1

SECTION 11

ASSEMBLY DRAWINGS, PARTS & SCHEMATICS

A463CCRO08A - SERVO, DUMP & FILTER ASSY

For use with AR185 Pump

AR250 pump version uses A473CCRO08A (larger plumbing)

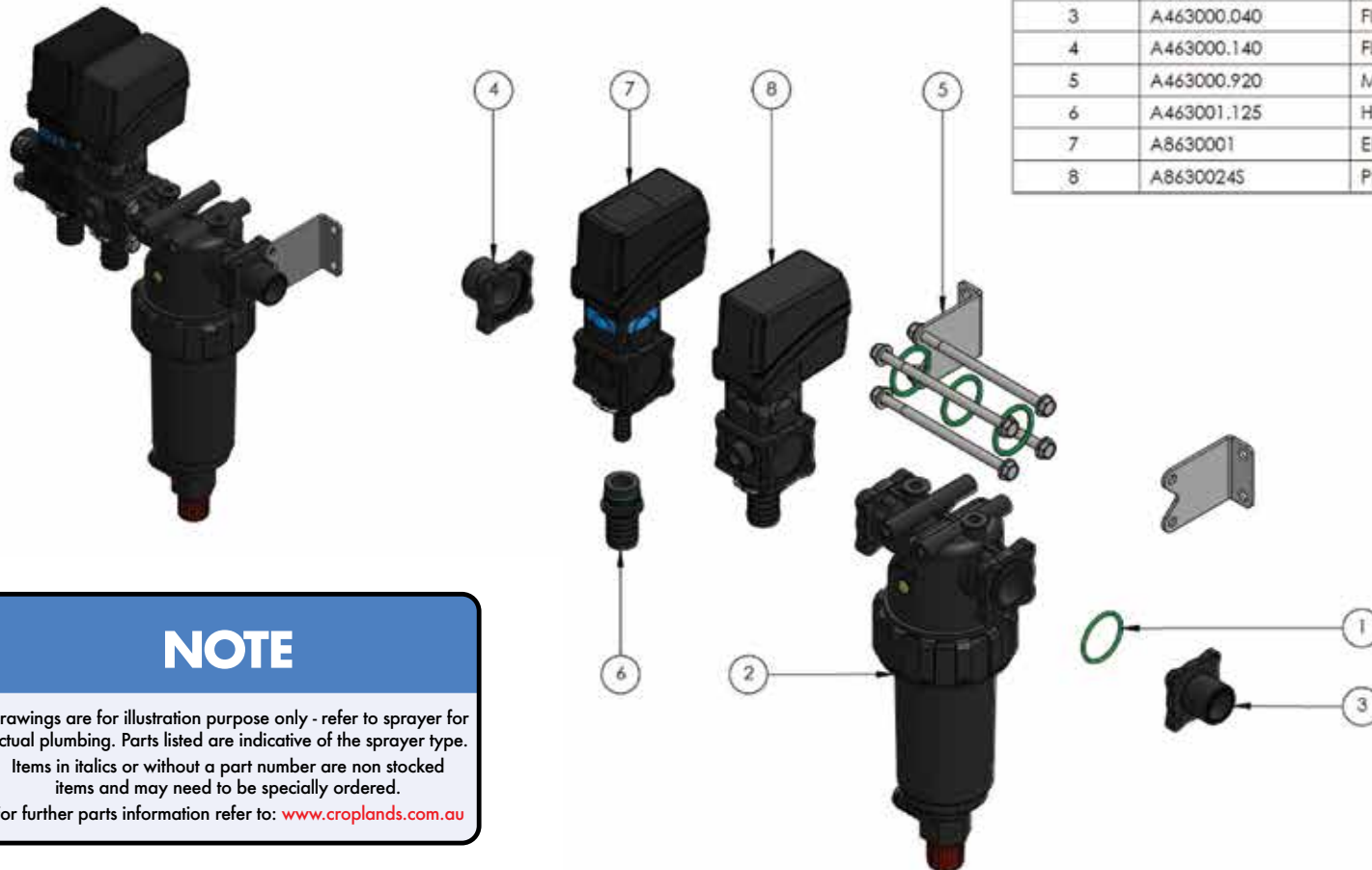

ITEM NO.:	PART NUMBER	DESCRIPTION	QTY.:
1	AG10071V	O RING 2" VITON	1
2	A32621135	FILTER S/F 80MESH FLANGED TYPE	1
3	A463000.040	FLANGE 463 SERIES 1" BSP	1
4	A463000.140	FLANGE FOR 463SER VALVE 1"	1
5	A463000.920	MOUNTING KIT 2 VALVE	1
6	A463001.125	HOSE TAIL 1" FOR 463 SERIES	1
7	A8630001	ELECTRIC VALVE	1
8	A86300245	PROP CONTROL VALVE 7 SEC	1

NOTE

Drawings are for illustration purpose only - refer to sprayer for actual plumbing. Parts listed are indicative of the sprayer type.

Items in italics or without a part number are non stocked items and may need to be specially ordered.

For further parts information refer to: www.croplands.com.au

SECTION 11

ASSEMBLY DRAWINGS, PARTS & SCHEMATICS

KH-5111 MANIFOLD ASSY, T5 4 NEG SECTIONS

Smart Sprayer 2019, 4 section spray.

NOTE

Drawings are for illustration purpose only - refer to sprayer for actual plumbing. Parts listed are indicative of the sprayer type.

Items in italics or without a part number are non stocked items and may need to be specially ordered.

For further parts information refer to: www.croplands.com.au

ITEM NO.	PART NUMBER	DESCRIPTION	QTY.
1	A010005	INLET FORK	1
2	A1091325	HOSETAIL T3M D.25	4
3	A1191525	ELBOW T5M D.25	1
4	A219250	ADAPTER PRESSURE GAUGE T5F	1
5	A863TA01	ELECTRIC VALVE 863T CANBUS	4
6	AG11058V	O RING VITON	4
7	AG11063	O RING EPDM	1
8	BJHB025038-90	ELBOW 1/4" NPT X 3/8" BARB	1

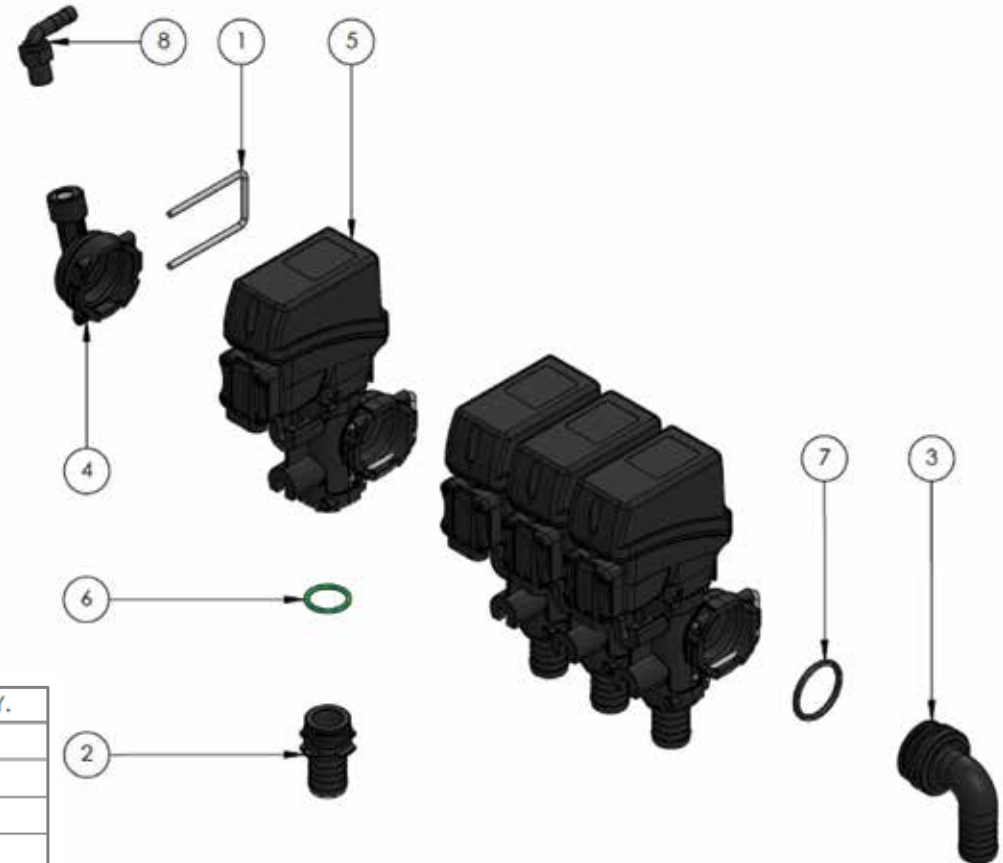

Please contact Technical support for further details

SECTION 11

ASSEMBLY DRAWINGS, PARTS & SCHEMATICS

KH-5112 MANIFOLD ASSY, T5 8 NEG SECTIONS

Smart Sprayer 2019, 8 section spray.

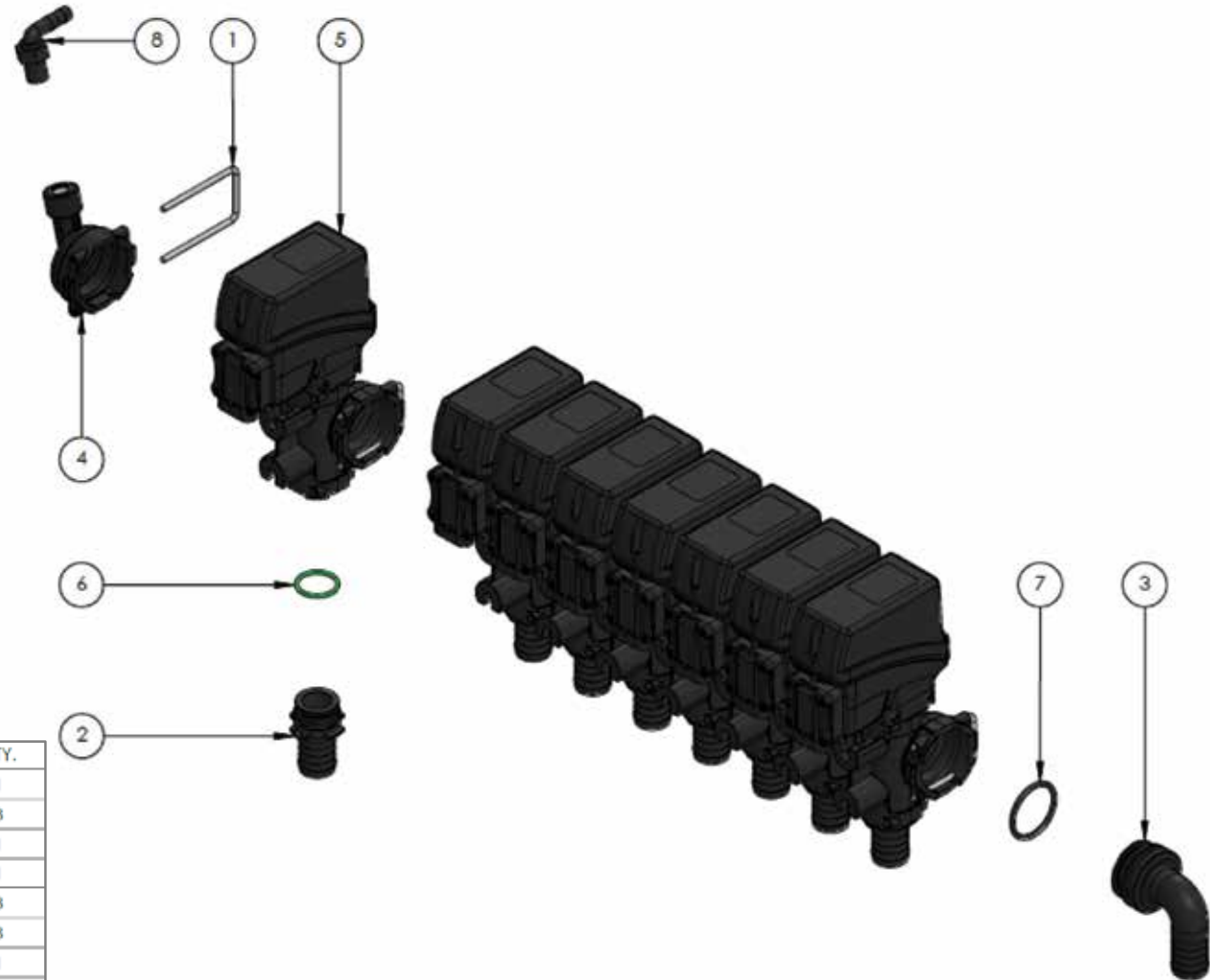

NOTE

Drawings are for illustration purpose only - refer to sprayer for actual plumbing. Parts listed are indicative of the sprayer type.

Items in *italics* or without a part number are non stocked items and may need to be specially ordered.

For further parts information refer to: www.croplands.com.au

ITEM NO.	PART NUMBER	DESCRIPTION	QTY.
1	A010005	INLET FORK	1
2	A1091325	HOSETAIL T3M D.25	8
3	A1191525	ELBOW T5M D.25	1
4	A219250	ADAPTER PRESSURE GAUGE T5F	1
5	A8631A01	ELECTRIC VALVE 863T CANBUS	8
6	AG11058V	O RING VITON	8
7	AG11063	O RING EPDM	1
8	BJHB025038-90	ELBOW 1/4" NPT X 3/8" BARB	1

Please contact Technical support for further details

SECTION 11

ASSEMBLY DRAWINGS, PARTS & SCHEMATICS

Refer to Recapture V2 manual (HT-OMRECAP2-A) for recapture drawings and schematics.

CROPLANDS

**OPERATORS MANUAL
QUANTUM MIST SMART SPRAYER
RECAPTURE
SYSTEM**

WWW.CROPLANDS.COM.AU

This mini-manual (HT-OMRECAP2-A) completely replaces the Recapture section (8) of the full and original HT-OMSMART-A sprayer operators manual.

STOP
BEFORE COMMENCING operation, **ENSURE** you read & understand this manual, its contents, and any additional information supplied.

HT-OMRECAP2-A | October 2022

SMART SPRAYER - FUSION SYSTEM SCHEMATIC

See Croplands Technical Support for more information.

Version B updating ... GPS & Mounts

Not shown is MT90-PWR loom

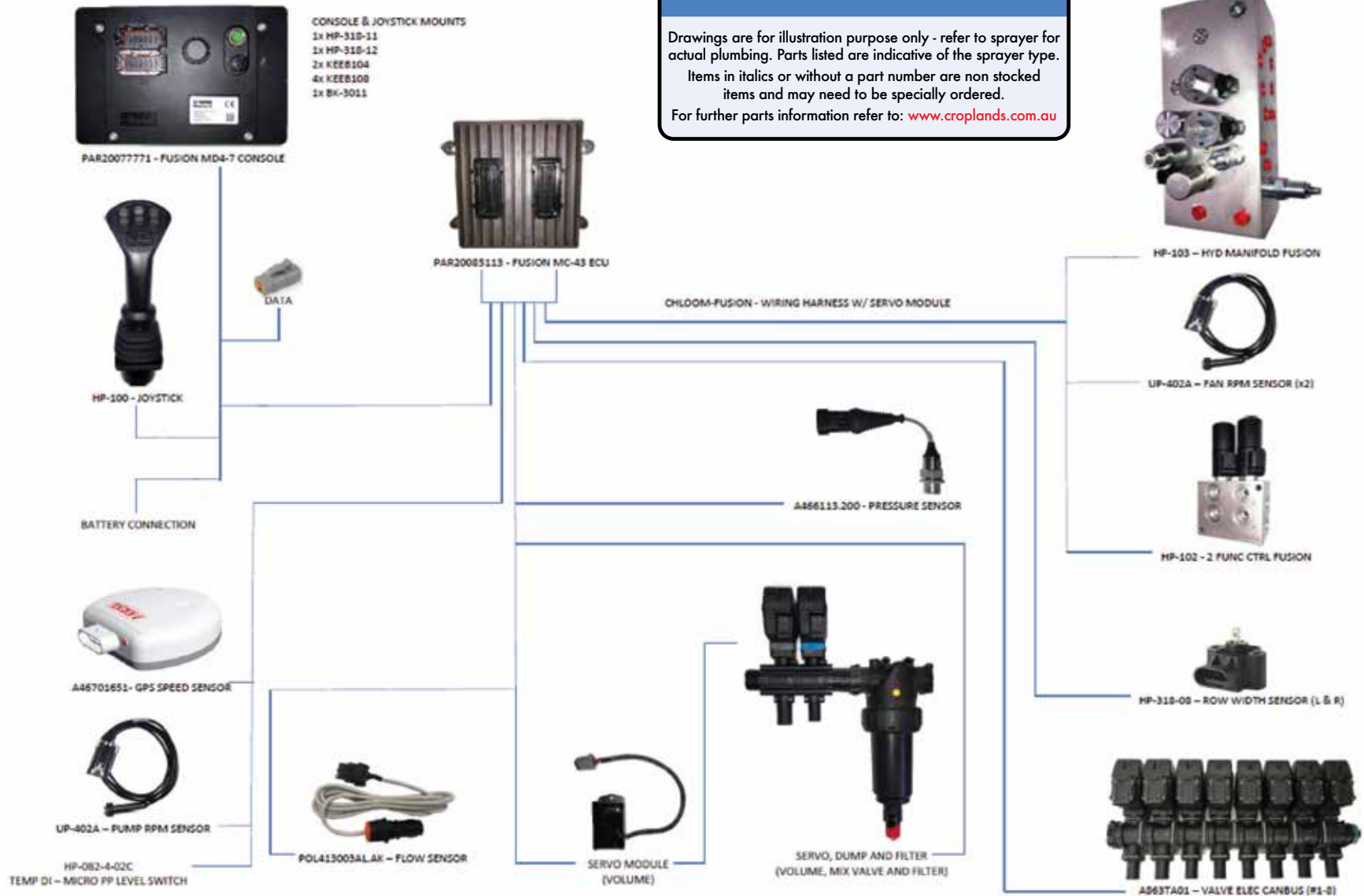

NOTE

Drawings are for illustration purpose only - refer to sprayer for actual plumbing. Parts listed are indicative of the sprayer type.

Items in *italics* or without a part number are non stocked items and may need to be specially ordered.

For further parts information refer to: www.croplands.com.au

Please contact technical support for further details

PLUMBING DIAGRAM - 2-ROW / 8 HEAD / 3000LT

SMART SPRAYER 2-ROW 8 HEAD 3000Lt PLUMBING DIAGRAM
SUCTION/PRESSURE LINE PLUMBING REV 0

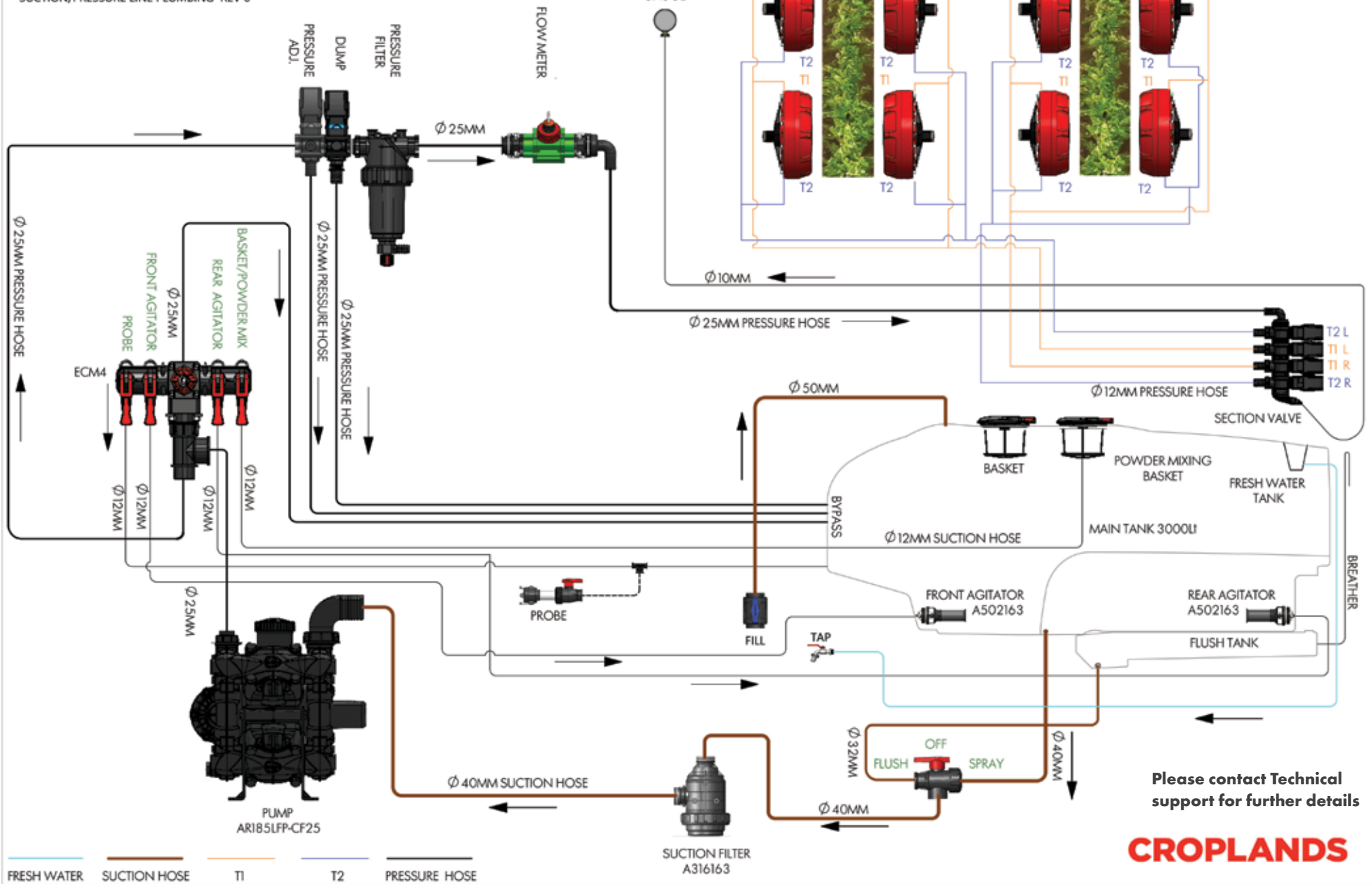

Please contact Technical support for further details

CROPLANDS

PLUMBING DIAGRAM - 3 ROW / 12 HEAD / 4000LT

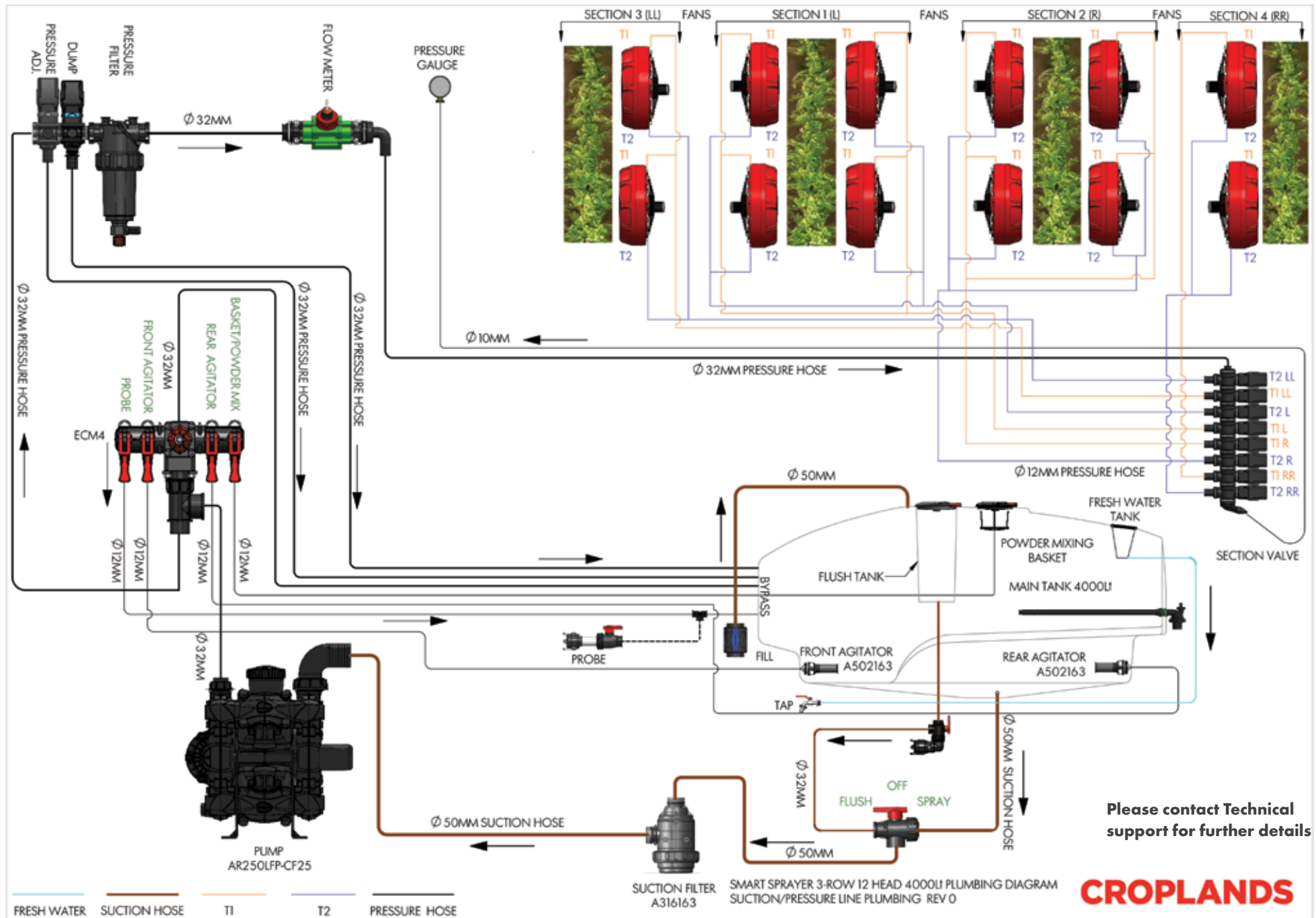

Please contact Technical support for further details

SMART SPRAYER 3-ROW 12 HEAD 4000L PLUMBING DIAGRAM
 SUCTION/PRESSURE LINE PLUMBING REV 0



SECTION 11

ASSEMBLY DRAWINGS, PARTS & SCHEMATICS

SMART SPRAYER FUSION HYDRAULIC SUPPLY - 3 ROW 18 FAN

NOTE - MOUNTING ORIENTATION OF HYDRAULIC MANIFOLD FUSION SS MAY CHANGE WITH MACHINE TYPE BUT PORTS REMAIN THE SAME.

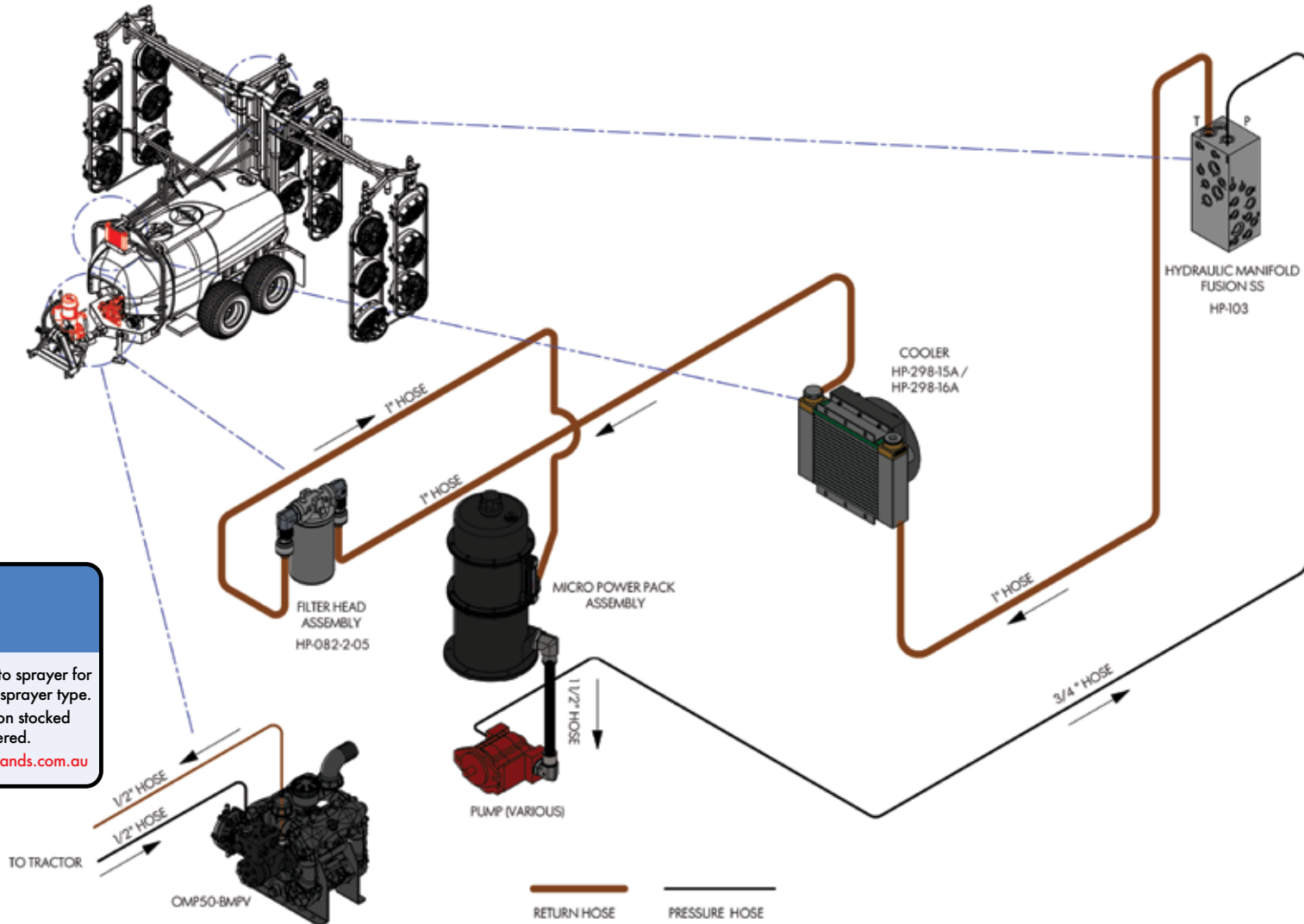

NOTE

Drawings are for illustration purpose only - refer to sprayer for actual plumbing. Parts listed are indicative of the sprayer type. Items in italics or without a part number are non stocked items and may need to be specially ordered. For further parts information refer to: www.croplands.com.au

HYDRAULIC DIAGRAM

SMART SPRAYER FUSION HYDRAULIC FAN CIRCUIT 3 ROW 18 FAN REV0

NOTE

Drawings are for illustration purpose only - refer to sprayer for actual plumbing. Parts listed are indicative of the sprayer type.

Items in *italics> or without a part number are non stocked items and may need to be specially ordered.*

For further parts information refer to: www.croplands.com.au

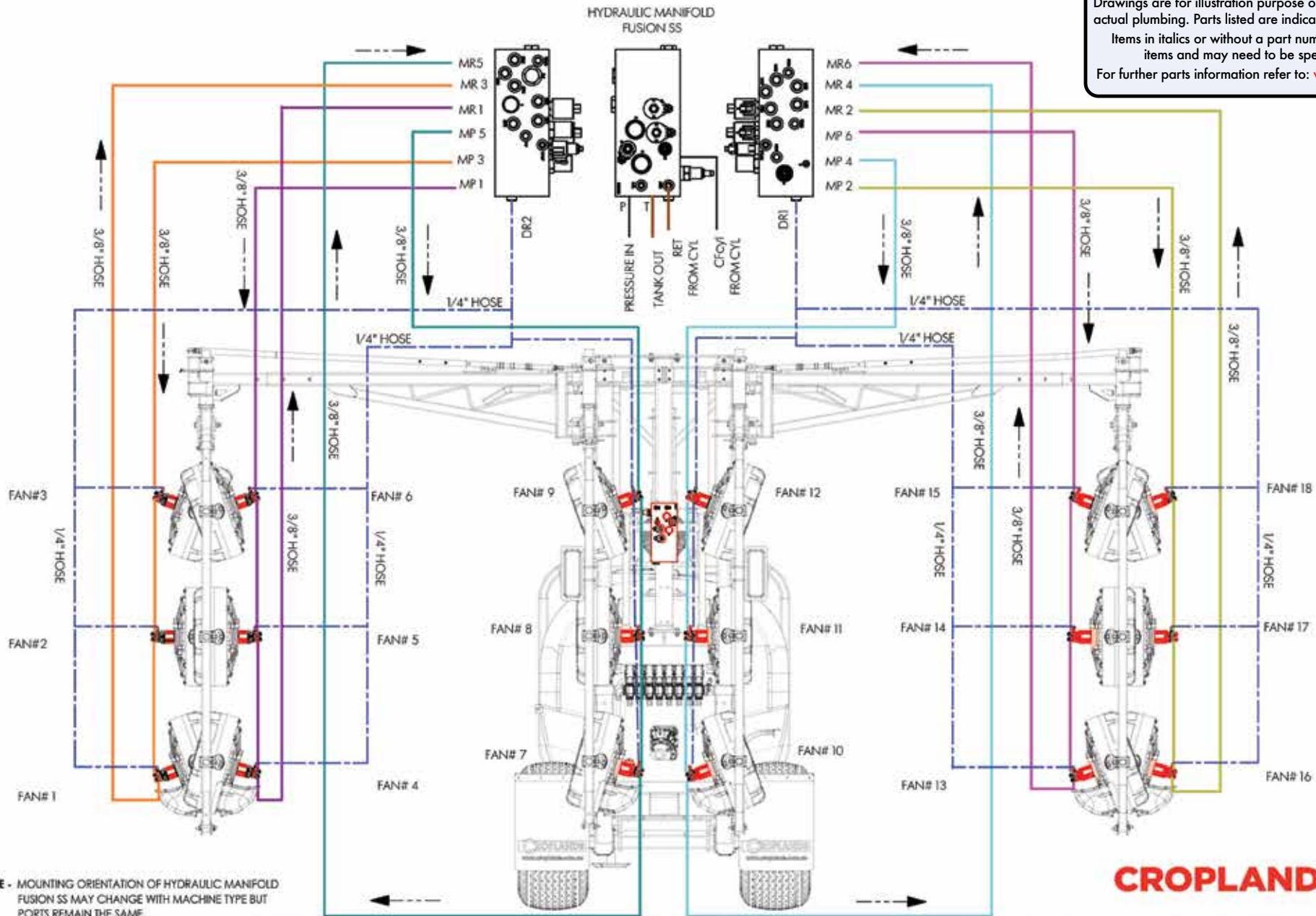

NOTE - MOUNTING ORIENTATION OF HYDRAULIC MANIFOLD FUSION SS MAY CHANGE WITH MACHINE TYPE BUT PORTS REMAIN THE SAME.

CROPLANDS

Please contact Technical support for further details

HYDRAULIC DIAGRAM

SMART SPRAYER FUSION HYDRAULIC BOOM & TERRACE CIRCUITS REV0

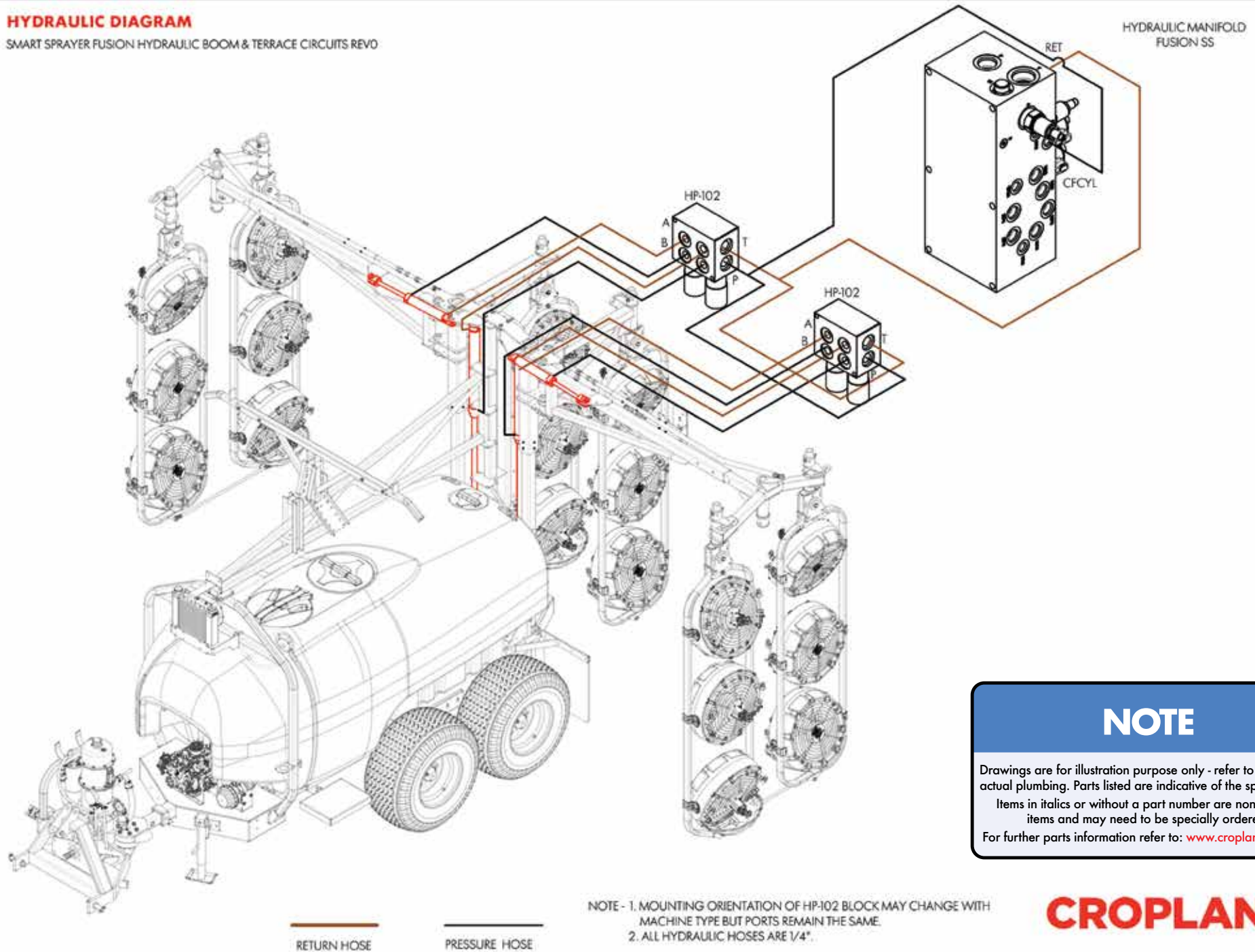

NOTE

Drawings are for illustration purpose only - refer to sprayer for actual plumbing. Parts listed are indicative of the sprayer type.

Items in italics or without a part number are non stocked items and may need to be specially ordered.

For further parts information refer to: www.croplands.com.au

CROPLANDS

Please contact Technical support for further details

CROPLANDS

AUSTRALIA

Croplands Equipment Pty Ltd
ACN 006 450 184

PO Box 2441
Dry Creek
50 Cavan Road
Dry Creek SA 5094
Australia

Freecall: 1800 999 162
Freefax: 1800 623 778
Email: sales@croplands.com.au
Website: www.croplands.com.au

NEW ZEALAND

Croplands Equipment Ltd
PO Box 2004,
Stortford Bridge, Hastings 4120

Location:
1422 Omaha Road,
Hastings 4120
New Zealand

Freecall: 0800 106 898
Freefax: 0800 117 711
Email: sales@croplands.co.nz
Website: www.croplands.co.nz

Your nearest Croplands Dealer
can be found in the dealer section
on the Croplands website