

CROPLANDS

OPERATORS MANUAL **CROPLINER**

1500XL | 2000XL | 3000XL | 4000XL | 5000XV

WWW.CROPLANDS.COM.AU

STOP

BEFORE COMMENCING
operation, **ENSURE** you read
& understand this manual, its
contents, and any additional
information supplied.



INTRODUCTION

GENERAL MANAGER'S WELCOME



A handwritten signature in black ink, appearing to read 'Sean Mulvaney'.

Sean Mulvaney
General Manager

Dear Customer

Congratulations on the purchase of your new Croplands Sprayer. Croplands have been in the business of building sprayer equipment since 1972. For over 50 years we have been supplying sprayers to farmers, contractors, growers and all our customers involved in growing crops and in the control of pests and diseases.

Croplands is a wholly owned subsidiary of Nufarm Ltd, the largest supplier of crop protection chemicals for Australasia, and one of the fastest growing global suppliers world-wide.

At Croplands, we pride ourselves on our commitment to supplying machinery that is at the forefront of the industry's needs. We believe we can back up our products and through

constant research and development, bring to you the best equipment you can find.

We welcome any feedback from you about our equipment.

On the back cover you will find our contact details, and locations where our staff can be reached during business hours. After hours, you can email us and expect a reply the following morning.

Please read this manual in its entirety before you operate your sprayer. This will ensure you have a trouble free start up.

We trust you will get years of good use from your Croplands Sprayer.

Yours Sincerely

Sean Mulvaney
General Manager

Croplands has taken steps to ensure this operator's manual is as current and as accurate as possible. Due to the ever-changing markets of cropping and farming, Croplands is constantly striving to be at the forefront of innovation and technology. While the information in this manual is considered accurate at the time of writing, Croplands reserves the right to change this information without notice. Croplands will not accept liability for any inaccuracy in this publication, or changes forthwith.

CONTENTS

SECTION 1 IMPORTANT INFORMATION

About this manual	4
Terminology	4
Before operating your sprayer	4
Warranty Policy	5

SECTION 2 SAFETY

Safety first	6
Safety signs and decals	7

SECTION 3 PRODUCT IDENTIFICATION, SHIPPING & SPECIFICATION

Product identification	8
Shipping information	8
Weights	8
Dimensions	9
General Specification	12

SECTION 4 PRODUCT FEATURES / FAMILIARISATION

Fieni Fans	17
Fan pitch angle	18
Gearbox	20
Adjustable vanes	21
Nozzles	21
Fan safety	22
Chassis, axle, wheel & tyres	23
Tanks, lids etc	25
5000 XV Model	27
4000 XL Model	28
3000 XL Model	30

2000 XL Model	32
1500 XL Model	33
Pumps	34
Pto Shafts	34
Spray System Overview	35
Controls	38

SECTION 5 PRE-OPERATION

Safety first	42
Hook up	42
Hook-Up HV4000 Auto Rate Controller	46
Hook-Up Bravo 180S	48
Hook-Up HV2400	48
Hook Up Manual Controller	48
Hook-Up Braglia Electric Controller	49
Functionality checks	50
Set-up spray pressure	53
General notes on auto-rate controllers	54
Configure the fan	56
Pre-Operation Checklist	57

SECTION 6 SPRAY OPERATIONS

Safety first	60
Filters	60
Filling the sprayer	62
Agitation	63
Mixing basket	63
Chemical suction probe	64
Calculate water & chemical quantities	65
Proceed to spray	66
Drain & flushing	66
Tank cleaning	68
Unhitching the sprayer from the tractor	69

SECTION 7 SPRAYING INFORMATION

Spraywise	71
Calibration	71
Flowmeter calibration	72
Step 1 - ensure equipment is in good working order	72
Step 2 - determining the actual speed of travel	74
Step 3 - determine spraying volume required	74
Step 4 - determine sprayer configuration	74
Step 5 - determine the ideal spray pressure	75
Step 6 - determine & select correct nozzles	75
Step 7 - fit & test selected nozzles	78
Step 8 - calculate the actual application rate	78
Step 9 - if the tested rate is unsatisfactory	79
Step 10 - coverage assessment	79
Step 11 - add the correct amount of chemical to the tank	80
Step 12 - record all data for future reference	80
Discs & Cores	83
Calibration work sheets	85

SECTION 8 LUBRICATION & MAINTENANCE 93

SECTION 9 TROUBLESHOOTING 99

SECTION 10 ASSEMBLY DRAWINGS, PARTS & SCHEMATICS 103

SECTION 11 INDEX 122

SECTION 1

IMPORTANT INFORMATION

ABOUT THIS MANUAL

This manual provides assembly, setting up, operating and maintenance instructions for the Croplands Cropliner XL series of sprayers.

In addition to this manual, the sprayer will be delivered with the General Safety Manual (GP-SAFE-A) and where applicable the Controller Manual. For details not covered by the manuals, please contact Technical Support on 1300 650 724.

Some features and options explained in this manual may not be installed on your sprayer.

Please pass on this manual with the sprayer at the time of resale for usage by the new owner.

This manual, HT-OMCROPLINE-E, was first published in June 2022.

Check online as there may be more recent revisions of this manual. www.croplands.com.au

TERMINOLOGY

These terms/symbols used throughout this manual:



NOTE	This Note sign is in place to convey useful information and will help you to identify the best possible way to operate the machine.
CAUTION	This Caution sign shows the potential for incident. An incident may include damage to the machine itself, or possible injury to the operator.
WARNING	This Warning sign shows the potential for risk or injury and highlights the need for steps to be taken to protect ones safety.
DANGER	This Danger sign will be used in areas where the highest risk is present. Always read the information on these signs and ensure you are taking steps to prevent risk or injury.

BEFORE OPERATING YOUR SPRAYER

Before attempting to use your sprayer, make sure you read all Operator Manuals for this sprayer including but not limited to:

This Operator's Manual, **and all other supplied manuals** for items such as Pumps and PTO etc.

And properly understand:

- All Safety Issues.
- Assembly & Installation instructions.
- Calibration of the sprayer.
- Sprayer Operation.
- Sprayer Maintenance.

NOTE

To convey useful operating information.



CAUTION

To highlight potential injury or machinery damage.



WARNING

To stress potential dangers and the importance of personal safety.



DANGER

Probability of death or serious injury if an accident occurs

SECTION 1

IMPORTANT INFORMATION

WARRANTY POLICY

Each sprayer will be delivered with a Specifications, Safety, Warranty & Delivery Booklet which includes:

- the sprayer's specification sheet including the sprayer's unique serial number,
- a safety induction checklist,
- a delivery checklist and customer induction,
- the Croplands Warranty policy and warranty registration form.

Always contact your Croplands Dealer first and foremost for warranty matters.

NOTE

For full conditions of warranty and warranty policy, please see the Specification, Safety, Warranty & Delivery booklet provided with this sprayer.

SPRAYER SPECIFICATIONS SAFETY, WARRANTY & DELIVERY HORTICULTURE

WWW.CROPLANDS.COM.AU

STOP
BEFORE COMMENCING
operation, **ENSURE** you read
& understand this manual, its
contents, and any additional
information supplied.

GP-WARH-B

INCLUDES SAFETY INDUCTION

SECTION 2

SAFETY

SAFETY FIRST

Please read and understand all supplied manuals, guides and safety decals before operating this sprayer. This includes the **Croplands Operators Safety Manual** – as pictured here.

This manual is available on the Croplands Web site, or for printed versions contact Croplands customer support and ask for part number GP-SAFE-A (or later version if available).



SECTION 2

SAFETY

SAFETY SIGNS AND DECALS

All signs and decals for sprayer safety and operation must be maintained in good order and replaced if damaged or missing. Most Croplands labels have a part number printed on the decal to aid identification and replacement.

Some examples are shown below.



Part No: XD - 123

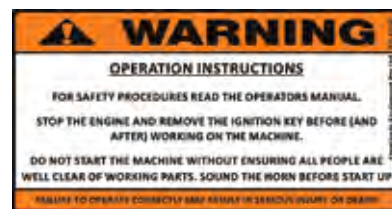

Part No: XD - 125V



Part No: XD - 126V

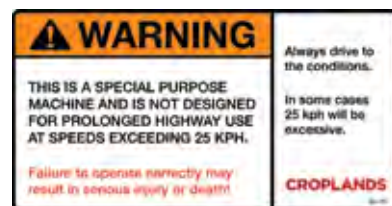

Part No: XD - 176



Part No: XD - 127V



Part No: XD - 122V



Part No: XD - 127V

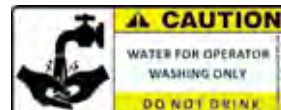

Part No: XD - 127V

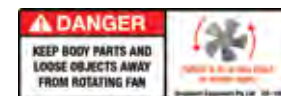

Part No: XD - 195



Part No: XD - 175

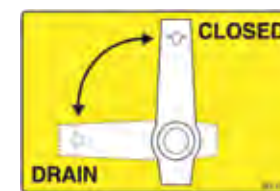

Part No: XD - 115

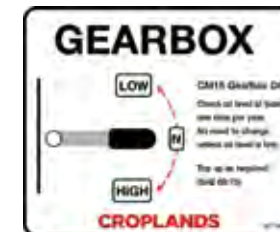

Part No: XD - 164

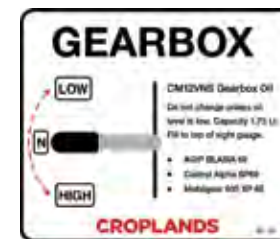

Part No: XD - 157

SECTION 3

PRODUCT IDENTIFICATION, SHIPPING & SPECIFICATION

PRODUCT IDENTIFICATION

Always use the serial number of the Sprayer when requesting service information or when ordering parts.

Early or later models (identification made by serial number) may use different parts, or it may be necessary to use a different procedure for specific service operations.

The serial numbers of all controllers, pumps etc should also be recorded for future reference.



SHIPPING INFORMATION

All provided tie down points (and more) should be used to help secure the sprayer for transporting.

Note serial number plate in the attached image.



WEIGHTS

The below is a general guide to standard model empty weights. For more detailed information consult the Croplands Customer Service team.

Cropliner Model	Weight (single axle versions)
XL 1500Lt - 920DSV Fan	
XL 2000Lt - 920DSV Fan	766kg
XL 3000Lt - 920DSV Fan	
XL 3000Lt - 1060DSV Fan	
XL 4000Lt - 920DSV Fan	
XL 4000Lt - 1060DSV Fan	1160 kg
XV 5000Lt - 1060DSV Fan	
Tandem axle, 2000XL - 920 Fan	
Tandem axle, 3000XL - 920 Fan	
Tandem axle, 4000XL - 1060 Fan	
Tandem axle, 5000XL - 1060 Fan	2018 kg

SECTION 3

PRODUCT IDENTIFICATION, SHIPPING & SPECIFICATION

DIMENSIONS CROPLINER 1500/920DSV

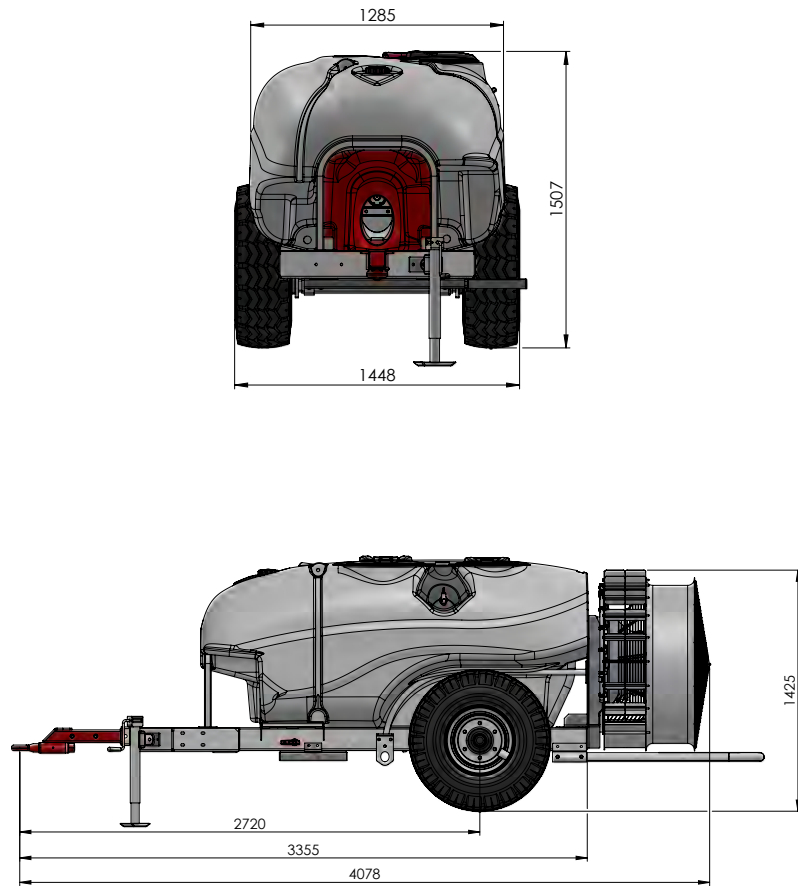

DIMENSIONS CROPLINER 2000/920DSV

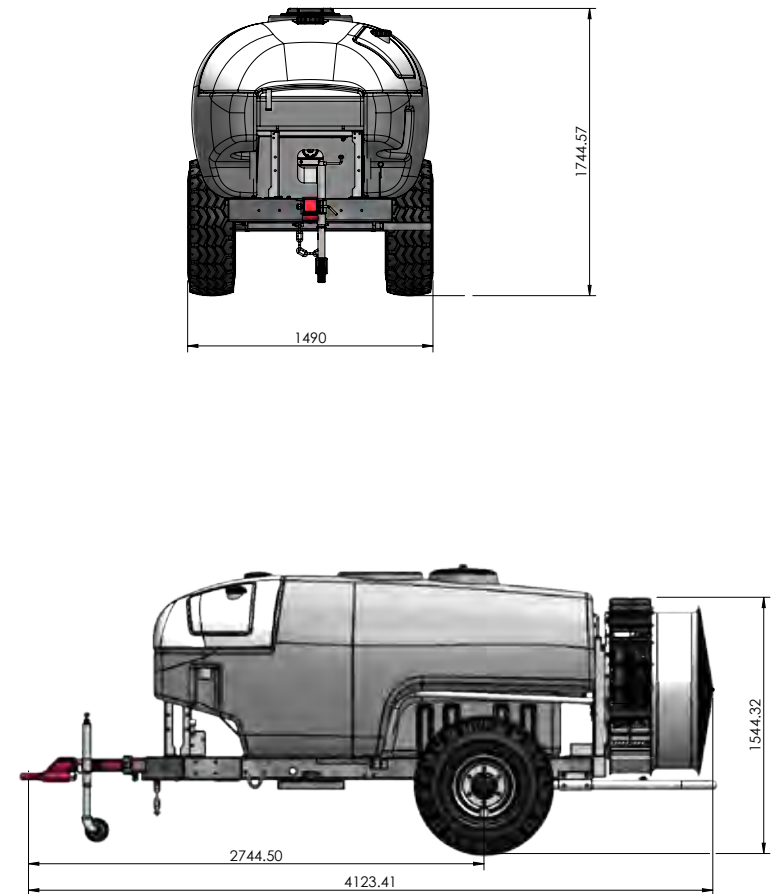

SECTION 3

PRODUCT IDENTIFICATION, SHIPPING & SPECIFICATION

DIMENSIONS CROPLINER 3000/1060DSV

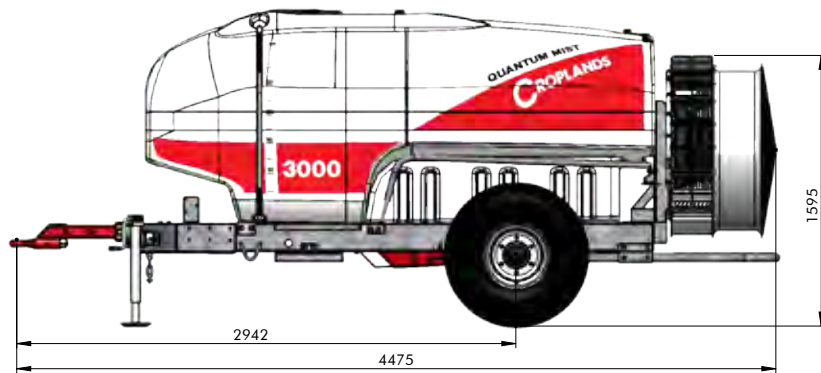
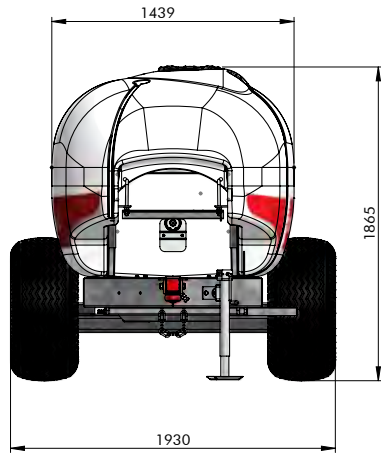

DIMENSIONS CROPLINER 4000/1060DSV

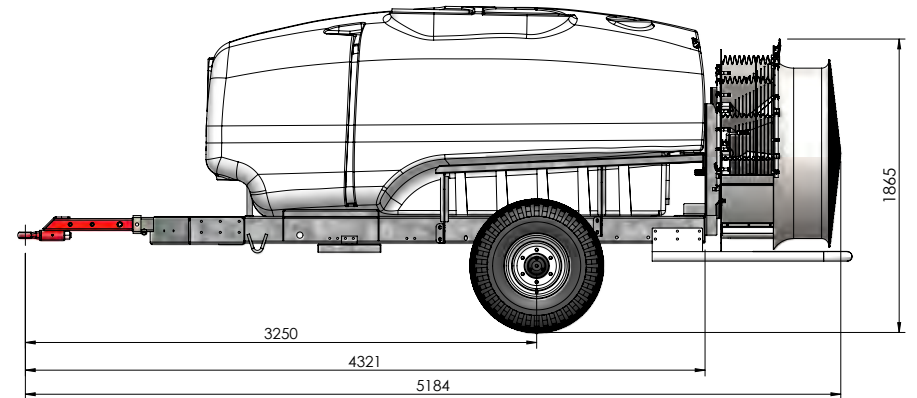
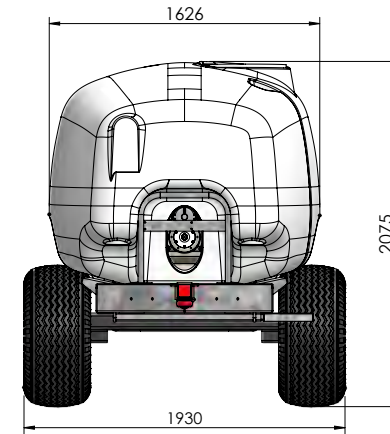

SECTION 3

PRODUCT IDENTIFICATION, SHIPPING & SPECIFICATION

DIMENSIONS CROPLINER 5000 / 1060 DSV SINGLE AXLE

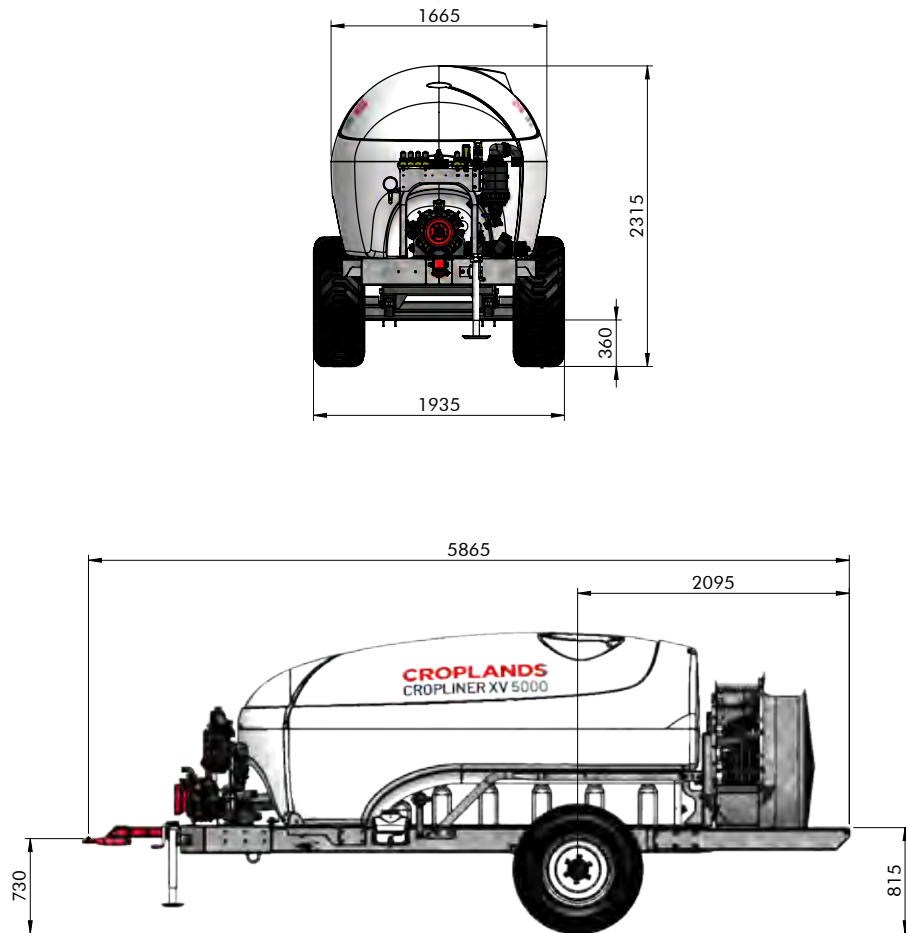

DIMENSIONS CROPLINER 5000/1060DSV; TANDEM AXLE

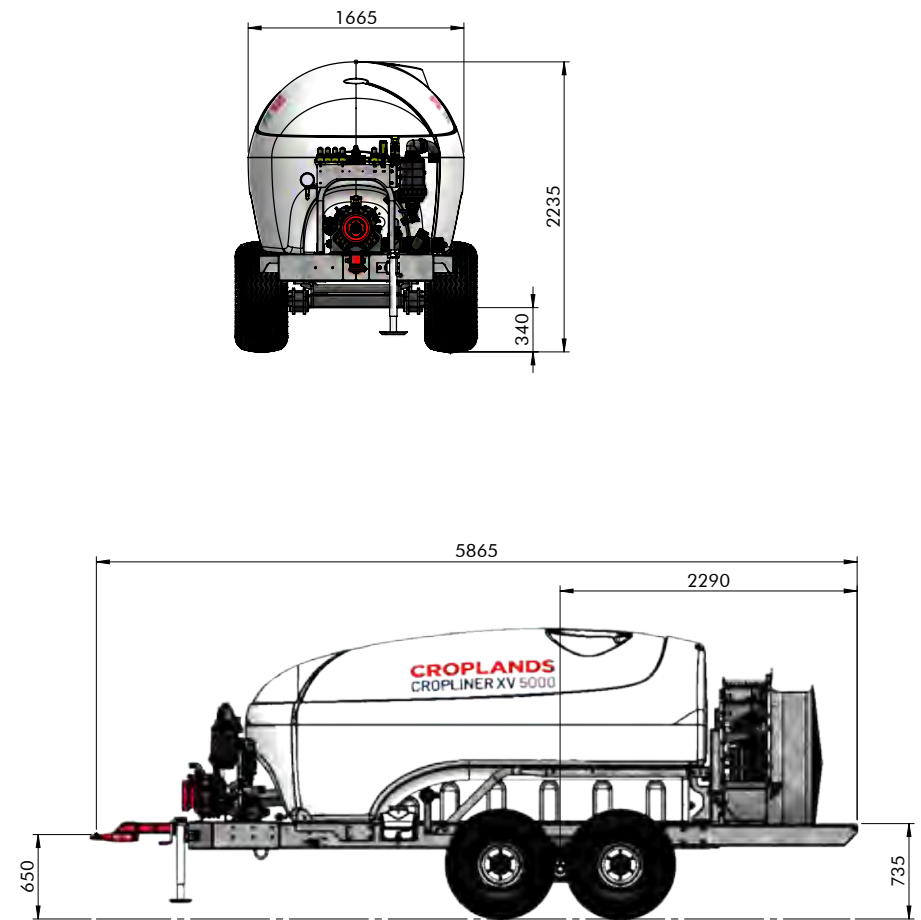

SECTION 3

PRODUCT IDENTIFICATION, SHIPPING & SPECIFICATION

GENERAL SPECIFICATION

The Croplands range of Cropliner sprayers are built with a respect for Australia and New Zealand's tough and varying terrain.

Engineered to endure, Croplands spraying equipment gives growers the confidence to take on row after row.

The sprayers are available with a wide selection of tank sizes, fan sizes and options.

For more detailed specification, see Section 4, Product Features / Familiarisation.

Please note this manual is applicable to the XL and XV models from 1,500 Litres to 5,000 litres capacity.

The Slimline 2000 models use a different manual.

HIGH PERFORMANCE AIR BLAST FANS

All our air-blast fans are engineered by Fieni, a global leader in agricultural fan design, manufacturing, and innovation.

Croplands and Fieni have been collaborating since 1972, and together we set the standard for fan sprayer performance, efficiency, penetration, and coverage.

For performance specification, see Page 17.



920MM DSV FAN

Stainless steel volute.

Variable pitch, high strength, glass-reinforced nylon blades – shaped for maximum air delivery with lowest possible power input.

2-speed heavy-duty gearbox and centrifugal clutch.

Stainless steel spray ring with 14 brass roll-over nozzle bodies per side.

Fully guarded for safety.

83,798m³/hour max air output.



1060MM DSV FAN

Stainless steel volute.

Variable pitch, high strength, glass-reinforced nylon blades – shaped for maximum air delivery with lowest possible power input.

2-speed heavy-duty gearbox and centrifugal clutch.

Stainless steel spray ring with 15 brass roll-over nozzle bodies per side.

Fully guarded for safety.

108,618m³/hour max air output.

SECTION 3

PRODUCT IDENTIFICATION, SHIPPING & SPECIFICATION



920MM LINEAR TOWER FAN

Stainless steel volute.

Variable pitch, high strength, glass-reinforced nylon blades – shaped for maximum air delivery with lowest possible power input.

Stainless steel spray ring with 13 brass roll-over nozzle bodies per side.

Fully guarded for safety.

83,7908m³/hour

Delivers even coverage in the narrowed plantings



Upper and lower deflector kits for 1060 fan.

FIKIT00000044	Upper deflector kit for 1060 DSV fan (L/R air deflectors) fitted
FIKIT00000045	Lower deflector kit for 1060 DSV fan (L/R air deflectors) fitted
HT-TOPACTUATORS	Upper deflector, electric actuator kit for 1060DSV fan (shown above)

SECTION 3

PRODUCT IDENTIFICATION, SHIPPING & SPECIFICATION



Tanks (sight gauges / sump / drain)

All tanks are constructed of impact-resistant polyethylene and UV stabilized.

Main tank capacities range from 1,500 litres to 5,000 litres and feature

- Flip open filling lid with large basket strainer.
- Quick fill system (camlock direct fill).
- Calibrated sight tube for filling level indication.
- Drain completely via a large drain valve and sump.

All XL models are supplied with a Flushing tank. No Flushing tank is fitted to the XV model.

All models are supplied with a Hand-wash / freshwater tank with conveniently positioned tap.

Chassis & drawbar

Hot-dipped galvanised full-length, heavy-duty chassis with adjustable draw bar. Slide-out step (not on 5000) & jockey stand.



Axle

Cropliner 1500, 2000, 3000 & 4000 litre models are fitted with a single fixed axle as standard. The 5000 litre model is fitted with single suspension axle as standard.

- Optional Adjustable height and width axle for 2000 and 1500 litre models on single axle
- Optional suspension for 1500 and 2000 litre Cropliner (non-adjustable axle)
- Optional suspension for 3000 and 4000 litre Cropliner (non-adjustable axle)
- Optional Tandem walking beam axle available for all models except the 1500 litre.

Wheels & Tyres

11.5/80 x 15.3 wheels with tubeless tyres are fitted as standard to the 1,500 and 2,000 Litre models.

400 x 15.5" flotation tyres are fitted as standard on 3,000 & 4000 Litre models.

400 x 22.5" wheel & tyres are fitted as standard to the 5,000 Litre model

Drive/PTO

A heavy-duty PTO shaft is supplied to drive the pump. Wide angle PTO shafts are available as an option.

- Optional Wide angle PTO shaft

Pumps

All Cropliner Sprayers are fitted with an Annovi Reverberi positive displacement diaphragm pumps with a capacity of 140 to 260 L/min - depending on the sprayer model.

- Optional ARBHS200 brass pump in lieu of the "where normal" ARBHS170

Agitation

The agitation system is driven by the pump via twin supra-flow venturis tank agitators & bypass agitation.

Single agitator for the 1,500 model.

Nozzles

Brass roll-over nozzle bodies fitted with 1 set stainless steel disc and brass cores and 1 set ALBUZ ceramic hollow cone nozzles to allow a greater choice of application rates.

Note the customer can specify the specific nozzle requirements at the time of order.

Each sector of nozzle body(s) is fitted with a non drip diaphragm.

SECTION 3

PRODUCT IDENTIFICATION, SHIPPING & SPECIFICATION



Filtration

Lid-strainers & chemical mixing baskets are standard on all models.

Large suction filter and optional high pressure brass pressure filters.

Chemical Handling

Quick fill system and chemical suction probe standard on all models.

Speed Sensors

Proximity sensors are used for Wheel (travel) speed.

Controls

Manual remote mounted ARBMH50 controller standard. Functions include left/right, shut-off, simultaneous shut-off, full bypass, pressurised bypass, manual pressure adjustment with pressure gauge.



Options:

- Electric – high pressure solenoid valves, 2-section in-cab control with electric pressure adjustment
- Croplands HV-2400, 2-section auto-rate controller
- HV-4000 auto-rate controller, 2-section (left/right) with optional 4-section control (left/right/upper/lower)
- Bravo 180S auto-rate controller, 2-section (left/right) with optional 4-section control (left/right/upper/lower)

Factory fitted options (other)

- NuPoint GPS tracking, mapping & data.
- In some models the Flushing tank is optional.
- Various fan options are available, such as ...
 - Linear tower (see buyers guide)
 - Deflector kits (see buyers guide)
 - Tall tree volute (see buyers guide)



Tractor requirements

Tractor size / power required is dependent upon a combination of weight (sprayer tank capacity), fan (size and pitch angle setting) and farm conditions (soil and terrain).

Approximate engine HP requirements.

Models with:

920 DSV fan = 70 HP

1060 DSV fan = 105 HP

Also see Fan specification information for fan only requirements (page 17).

Sprayer specifications are subject to change without prior notification

SECTION 4

PRODUCT FEATURES / FAMILIARISATION

FIENI FANS	17
FAN PITCH ANGLE	18
GEARBOX	20
ADJUSTABLE VANES	21
NOZZLES	21
FAN SAFETY	22
CHASSIS, AXLE, WHEEL & TYRES	23
TANKS, LIDS ETC	25
5000 XV MODEL	27
4000 XL MODEL	28
3000 XL MODEL	30
2000 XL MODEL	32
1500 XL MODEL	33
PUMPS	34
PTO SHAFTS	34
SPRAY SYSTEM OVERVIEW	35
CONTROLS	38

SECTION 4

PRODUCT FEATURES / FAMILIARISATION

FIENI FANS

The attached table lists the performance details for each Cropliner Fieni fan model.

The DSV fan was designed for low noise and lower power absorption, while still guaranteeing a large air volume.

The 9 blades of the DSV fan are made of a composite material and have been specifically designed to guarantee high performance.

Rear intake fans run anticlockwise.

The fan blades can be set at three different pitch angles to adapt the Fieni sprayer unit to the power of the tractor available. All Cropliner sprayers are tested and supplied with the fan set to the **middle blade pitch setting**.

The fans are equipped with a centrifugal clutch made of metal with brake lining.

Each fan is PTO shaft driven via a 2 speed (plus neutral), low maintenance, heavy duty gearbox.

Designed for maximum PTO speed = 540 rpm.

Each fan has a series of small independent moveable flat blades fitted on the air outlet, to help direct the air to where it is required.

Each side of the fan is a stainless steel "spray ring" with 13, 14 or 15 nozzles per side. Each nozzle is of the brass "roll-over" type.

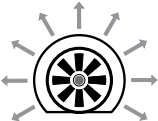
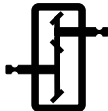
	920 LINEAR TOWER (LT) FAN	920 DSV FAN	1060 DSV FAN	
ORDER CODE	KH-5037	KH-5035	KH-5040	
9-BLADE FAN				
	Fan blade diameter mm	913	913	1,060
	Standard RPM (PTO 540) (High)	1,780	1,780	1,780
OUTPUT AND POWER				
	Pitch	26°	26°	64°
	M3/HR	73,682	73,682	84,696
	HP	26.4	26.4	35.38
	Pitch	34°	34°	72°
	m3/hr	81,285	81,285	99,929
	HP	36.9	36.9	50.08
	Pitch	42°	42°	80°
	M3/HR	83,798	83,798	108,618
	HP	47.5	47.5	70.23
FAN GEARBOX MODEL				
	2-speed plus neutral	2 + N	2 + N	2 + N
	Low box ratio	1:2.93	1:2.93	1:2.93
	High box	1:3.29	1:3.29	1:3.3
PERFORMANCE* (*in ideal conditions)				
	Y = metres	6	8	10
	Z = metres	15	14	16
	Suitable tank size	1500 - 4000	1500 - 4000	3000 - 5000
	Recommended tractor HP	≥ 65	≥ 70	≥ 105
	Nozzles per side	13 + 13 (26)	14 + 14 (28)	15 + 15 (30)
	Noise rating (dB) @ 7.5m	92	92	96
	Fan weight	178	130	188

The maximum canopy height and width figures are entirely subject to the canopy density, size, shape and weather conditions.

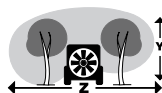

SECTION 4

PRODUCT FEATURES / FAMILIARISATION

FAN PITCH ANGLE

All Cropliner fans have multiple pitch settings and are normally supplied in the middle position.

To maximise performance, the blade pitch can be adjusted to match the tractor's capability / chosen operating parameters such as PTO rpm.

To increase the blade angle will increase air (spray) velocity and penetration, increase noise, and increase tractor power requirements. Note the power increase on a 1060 fan is very significant.

The reverse is true for reducing pitch angles.

Adjusting the pitch angles can be done on the sprayer as follows.

- a. Disconnect the PTO drive.
- b. Remove the safety fan guard.
- c. Remove the hub cover.
- d. Loosen the fan hub bolts.
- e. It's now possible to move the blades. All blades need to be set to the same pitch angle.
- f. Re-tighten the fan hub bolts. Makes sure the hub is snugly fitting back together – if not, it's a sign that one or more of the fan blade splines are not correctly fitted.
- g. Re-attach the hub cover, and safety guards.

Fan Set-up

The fan has the following adjustments available.

- Fan pitch angle
- Gearbox ratio
- Adjustable vanes
- Adjustable nozzles

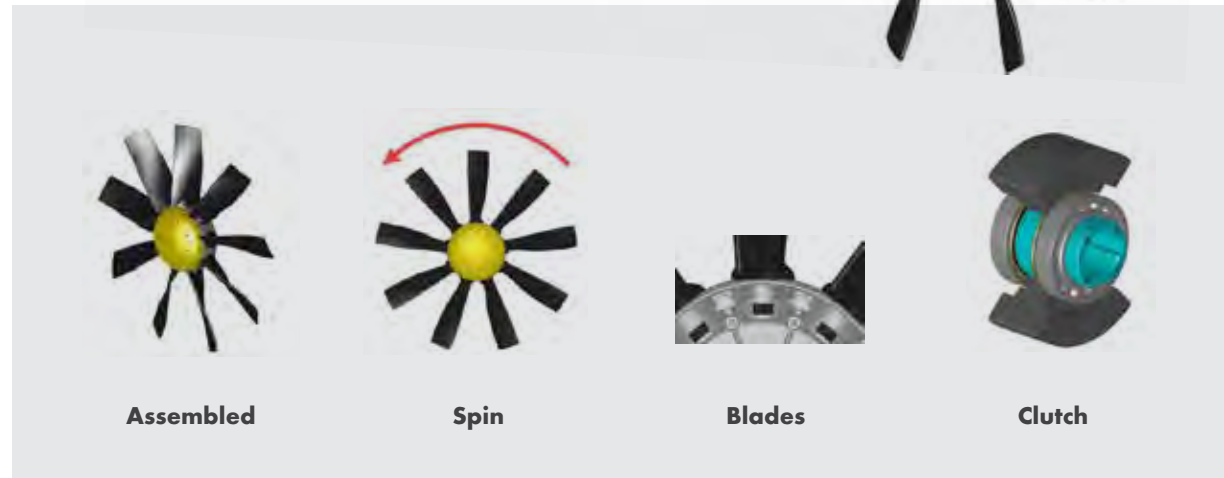

SECTION 4

PRODUCT FEATURES / FAMILIARISATION

The fan has been supplied "balanced". Swapping blades and hub components around risks upsetting the balance.

Do not operate with damaged fan blades.

If replacing a damaged blade, it's necessary to balance the fan.



VNS-A Fan
(rear air intake anti-clockwise)

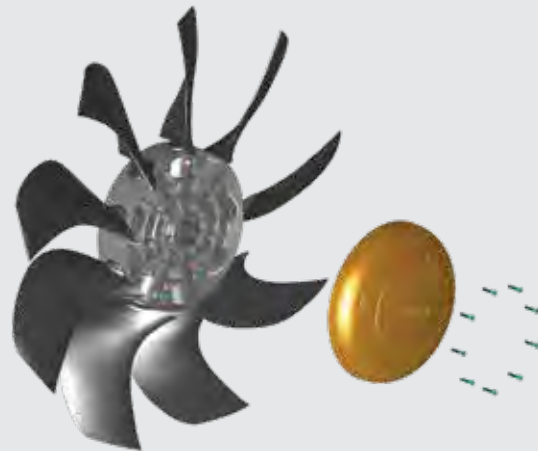

VNS-O Fan
(front air intake, clockwise)

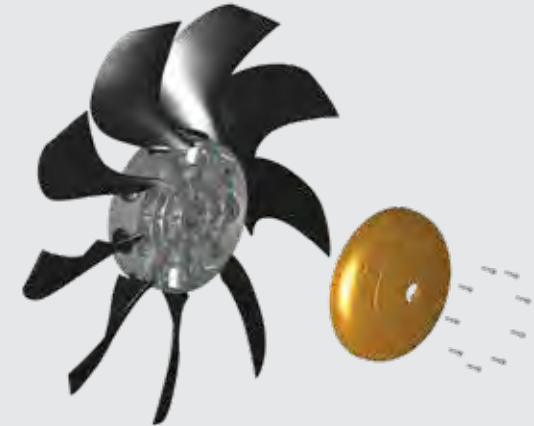

SECTION 4

PRODUCT FEATURES / FAMILIARISATION

GEARBOX

There are 2 different gearboxes in the range (refer page 15) – both have a low ratio, neutral (as the middle setting) and high ratio. Handle positions changes from fan to fan as per below decals.

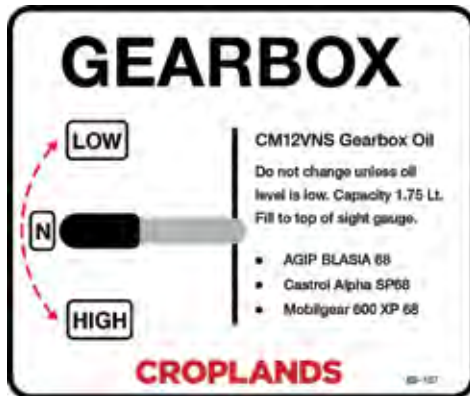

All units are supplied with a lever to engage and disengage the fan.

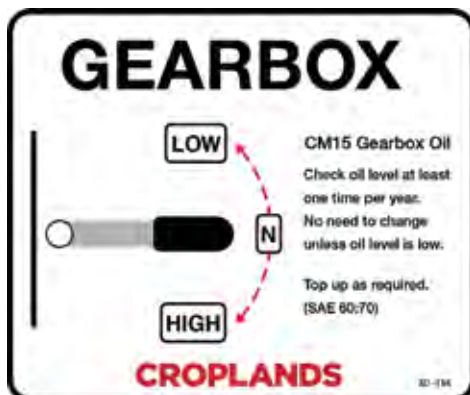

To avoid damage to the gears of the gearbox and to the sprayer unit, **always disengage the PTO drive before operating the gearbox lever / changing gears etc.**

Gearbox oil: Annually check the oil level of the gearbox and if the level is low (below the middle of the sight gauge) it's necessary to add the oil (SAE 60:70) up to reach the correct oil level. It is not necessary to change the oil once a year, but only to add oil if the level is low.

The oil level sight gauge may be viewed via a hole in the internal fairing (refer to image / **yellow arrow**).

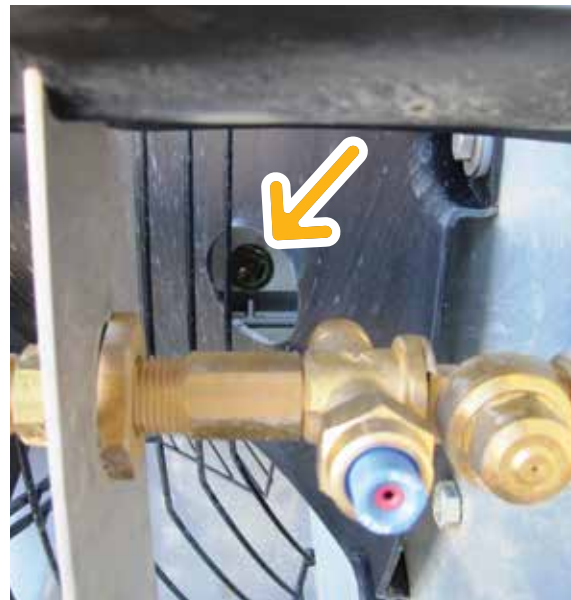

If a low oil level is detected, an investigation as to why the oil level has dropped should be undertaken.

To access the gearbox or the oil fill position will require the partial disassembly of the fan.

Fieni gearboxes use Agip Blasia 68 oil.

Some common equivalents are;

- Castrol Alpha SP68
- Mobilgear 600 XP 68
- Shell Omala S2 G 68

Fan	920DSV	1060
G/box	CM-12VNS	CM-15
Oil (ml)	1900	2200

Maximum PTO Speed

Maximum PTO speed is 540 rpm.

Check the tractor PTO RPM before operating the sprayer. More RPM at the PTO can give damage to the sprayer unit and can be dangerous for the operator.

SECTION 4

PRODUCT FEATURES / FAMILIARISATION



ADJUSTABLE VANES

Some fans and options feature adjustable vanes to better direct the air to where it's needed.

Adjustment of vanes is often done in conjunction with variations in nozzle selection.

NOZZLES

All Cropliner fans feature stainless steel spray rings with 13 (LT), 14 (920) or 15 (1060) brass roll-over nozzles per side. Maximum total of 26, 28 or 30 nozzles.

Each sprayer is supplied fitted with 1 set (26 ~ 30) stainless steel disc and brass cores and 1 set (26 ~ 30) ALBUZ ATR ceramic hollow cone nozzles to allow a greater choice of application rates.

Specific Nozzles to be selected at the time of ordering.

Each nozzle is fitted with a 1 Bar non-drip diaphragm.

The nozzle bodies are of the twin roll-over type enabling one of 2 nozzles to be selected or an off position as shown below in the vertical position.



SECTIONS

Generally the spray rings are configured as
Section 1 = left hand spray ring & nozzles
Section 2 = right hand spray ring & nozzles

SECTION 4

PRODUCT FEATURES / FAMILIARISATION

FAN SAFETY

Guards

The sprayer unit is supplied complete with safety guards for both incoming and outlet air. The assembled guards need to prevent foreign bodies hitting the fan.

NEVER operate the sprayer without these guards in place.



From time to time the incoming air guard may become clogged with leaves etc. Always disengage the fan before removing clogged leaves etc from the guards.

Bump / Leaf Guard

All Cropliner's are fitted with a galvanised steel Bump / Leaf guard. Do not remove this guard as it plays an important role in preventing damage to the fan housing and helps prevent ingestion of foreign objects.

Sprayers using the 920 fans are fitted with an adjustable length guard (note sliding tube in the below photo).



Sprayers using the 1060 fan are fitted with a non-adjustable heavy-duty guard (pictured left).

Fan Safety Rules



The fan runs at high speed and are capable of ingesting loose objects or clothing or ejecting objects that have been ingested at high speed.

- DO NOT exceed maximum operating rpm (PTO = 540 rpm)
- DO NOT stay in the working area (air inlet or spray outlet) of the sprayer unit.
- Always stay at a security distance from the machine when it is working/running.
- DO NOT remove or modify the installed protections and guards.



SECTION 4

PRODUCT FEATURES / FAMILIARISATION

CHASSIS, AXLE, WHEEL & TYRES

Chassis

Hot-dipped galvanised full-length heavy-duty chassis with optional axle types, adjustable drawbar, slide-out step (N/A for the 5000) & jockey stand.

Drawbar

The adjustable drawbar is supplied at its longest length. If required, it can be shortened by 2 holes (110mm spacing between each).



Jockey stand(s)

All Cropliners come fitted with an extendable Jockey Stand suitable for (tank empty) storage of the sprayer.

Upper right photo shows the jockey stand in the stowed position – it's recommended to remove from the sprayer when spraying.



Step / Platform access

The step, as pictured is in the stowed position.

For access to the tank lids and fill Camlock (2000 model) etc, the step must be moved and secured into the extended position.



For the 4000 and 5000 models, the lids are in a very difficult position to access via a step.

For these models, and for access to any other parts of a sprayer not readily accessed from the ground, the operator should use an appropriate platform step.

Such steps are commercially available from specialty suppliers. Larger purpose-built platforms are synonymous with well set-up sprayer filling stations.



Access to the top of a spray tank is best effected by using a purpose built platform.

SECTION 4

PRODUCT FEATURES / FAMILIARISATION



Axles

The standard and most popular axle is a fixed single axle. Options are available (refer to buyers' guide / price book).

WHEEL AND AXLE OPTIONS

HT-HP202V	31 x 13.5 – 15" flotation tyres in lieu of standard tyres for 2000 and 1500 litre models on single axle
HT-AXADJ	Adjustable height and width axle for 2000 and 1500 litre models on single axle
HT-SUS	Suspension for 1500 and 2000 litre Cropliner (non-adjustable axle)
HT-SUS4	Suspension for 3000 and 4000 litre Cropliner (non-adjustable axle)
HT-BP400W-2000	Tandem axle to suit 2000 litre model (4 x 11.5/80 x 15.3 tyres)
HT-BP400W-3000	Tandem axle to suit 3000 litre model (4 x 31 x 13.5 -15 flotation tyres)
HT-BP400W-4000	Tandem axle to suit 4000 litre model (4 x 31 x 13.5 – 15 flotation tyres)



Wheels & Tyres

For further identification of the axle, wheel, and tyre types see the Sprayer Specification Sheet that's included with every sprayer's Warranty & Pre-Delivery Booklet.

Standard tyre for 1500 / 2000 Lt models

HP-200, (11.5/80 - 15.3")
Rolling dia = 840mm
Width = 290mm



Standard tyre for 3000 / 4000 Lt models

HP-202GA, (400 x 15.5")
Rolling dia = 850mm
Width = 400mm



Optional flotation tyre 1500/2000 Lt models

HP-202V, (31 x 13.5 – 15")
Rolling dia = 810mm
Width = 345mm



Standard tyre for 5000 Lt models

HP-202HA, (400 x 22.5")
Rolling dia = 998mm
Width = 395mm



SECTION 4

PRODUCT FEATURES / FAMILIARISATION

Wheel Speed Sensor

All trailed sprayers optioned with Auto-rate control are fitted with a Speed Sensor – normally via a proximity sensor installed on the right-hand side wheel.

The sensor needs to be 5mm from the target, which in this case is the head of the wheel studs.



The sensor is reading cm per pulse.

A GPS speed sensor (Atlas 100) can be fitted as an alternative option.

TANKS, LIDS ETC

Most models feature three tanks, Main (chemical), Flushing (fresh water) and Hand-wash (fresh water) for operation, cleaning, and operator safety.

All Main tanks are equipped with large lid and basket filter. All models have a Basket/Powder Mix function activated via a tap from the pressure manifold, plumbed to the basket.



All Flushing (when fitted) and Hand-wash tanks are labelled as WATER ONLY. Replacement labels are available under the part no. XD-127V.



All Hand-wash taps are clearly labelled as WATER FOR OPERATOR WASHING ONLY. Replacement labels are available under the part no. XD-124V.

All sprayers have the Hand-wash tap positioned near the main filter.



All main tank and most flushing tank lids have integrated breathers.



SECTION 4

PRODUCT FEATURES / FAMILIARISATION

Hand-wash tanks do not have a breather. Always keep the area surrounding the hand-wash tanks clean and clear of chemical.



When inspecting the suction filter it is recommended to disengage the tractor PTO / spray pump to depressurize the system.



1. Turn off the flow at the tank selection valve.
2. Wear safety gloves when inspecting, cleaning or replacing the filter (s).



Filling of flush and fresh water / handwash tanks should ideally be via a separate / clean water source.

The main (suction) filter for all models is on the front left-hand side of the sprayer.

SECTION 4

PRODUCT FEATURES / FAMILIARISATION



5000 XV MODEL

The 5000 Litre Main tank is constructed of white opaque, UV stabilized, impact-resistant polyethylene with integral transmission tunnel.

The 5000 Lt main tank incorporates a flip open lid with large basket strainer. There is no basket rinse function.

This lid should NOT be used as a fill point unless the operator has a purpose-built platform to allow safe access to the lid.

Filling is via one of 2 methods (assuming the tank lid is not used as a fill point – above in red).

1. Quick fill camlock, direct bottom fill via tank sidewall (adjacent the Hand-wash tank). Fitted with a one way valve.
2. Separate 2" or 3" fill system mounted on the front left-hand side of the sprayer as pictured below (3" version shown).

Note: Due to the 5000 XV sprayer not having a separate Flushing tank, this is a triple-purpose system as it provides a means to flush the pump, fill via the pump and filling direct to tank. FRESH WATER ONLY.



Please dispose of any chemical in a safe and environmentally responsible manner.

The main tank has a single, calibrated level indication **sight gauge** tube and float on the front left corner.



Drain completely via the drain valve at the front of the tank. See tap handle in photo below.

The 5000XV does NOT include a Flushing tank.

SECTION 4

PRODUCT FEATURES / FAMILIARISATION

4000 XL MODEL

The 4000 Litre Main tank is constructed of white opaque, UV stabilized, impact-resistant polyethylene with integral transmission tunnel. Both the Flushing and Hand-wash tanks are integrated (welded) into the main tank.

This **Main** tank is fitted with a flip open lid (middle lid in picture above) with large basket strainer. There is a basket rinse function.



Do not use this lid as a fill point unless the operator has a purpose-built platform to allow safe access to the lid.



Towards the front of the main tank is an integrated 80 litre **Flushing tank** - FRESH WATER ONLY. **Orange arrow.**

Towards the rear of the main tank is an integrated 10 litre **Hand-wash tank** – FRESH WATER ONLY. **Blue arrow.**

Filling the main tank can be via the basket or via a remote fill tap and camlock at the rear of the sprayer. The top fill hose can be seen adjacent the Hand-wash lid **(Blue arrow).**



The main tank has a two, calibrated level indication **sight gauge** tubes with floats.

One at the front (right) side up to 3,000 litres and another on the left side of the sprayer to 4,000 litres.

SECTION 4

PRODUCT FEATURES / FAMILIARISATION



The main tank Drain is positioned near the step on the left-hand side of the sprayer. Please dispose of any chemical in a safe and environmentally responsible manner. **Blue circle.**



The 4000XL model is fitted with an external flushing fitting via camlock connection. The ball valve can direct flow to fill the flushing tank or to the tank selection valve which can be used to flush the complete plumbing system. **Orange circle.**



SECTION 4

PRODUCT FEATURES / FAMILIARISATION



3000 XL MODEL

The 3000 Litre Main tank is constructed of white opaque, UV stabilized, impact-resistant polyethylene with integral transmission tunnel.

This **Main** tank is fitted with dual flip open lids with large basket strainer. There is a basket rinse function.

Filling the main tank can be via the basket or the safer option via a remote fill tap and camlock at the rear of the sprayer. The fill hose can be seen at the rear of the sprayer. **(see green arrow).**

The 6 Litre **Hand-wash** tank is integrated (welded) into the main tank at the rear of the main tank. See outlet **(orange circle)**.
FRESH WATER ONLY.

The 90 Litre freshwater **Flushing** tank on the 3000 model is a separate tank that fits above the axle and below the main tank) and is filled via a fill tube accessed from inside the handwash tank at the rear of the sprayer **(see red arrow on next page)**.
FRESH WATER ONLY.

SECTION 4

PRODUCT FEATURES / FAMILIARISATION

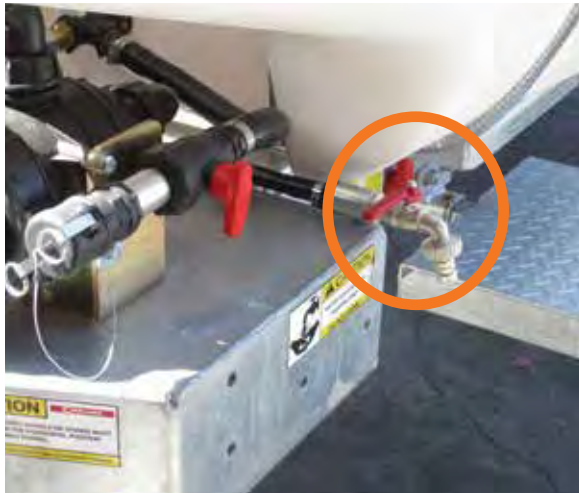

The main tank has a two, calibrated level indication sight gauge tubes with floats. One at the front (right) side and another on the left side of the sprayer.

The main tank Drain is positioned near the step on the left-hand side of the sprayer. [Blue circle \(previous page\)](#).

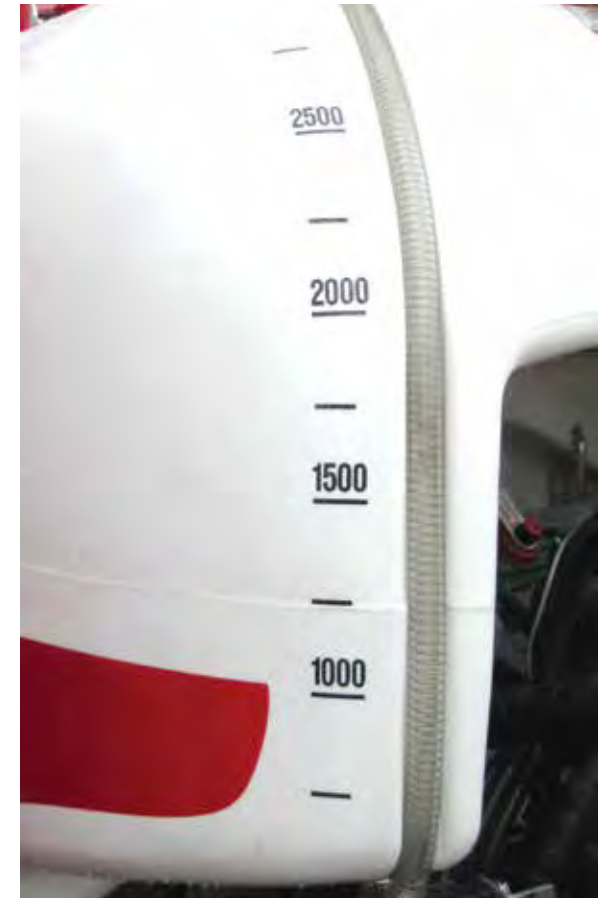

Please dispose of any chemical in a safe and environmentally responsible manner.

SECTION 4

PRODUCT FEATURES / FAMILIARISATION

2000 XL MODEL

The 2000 Lt Main tank is constructed of white opaque, UV stabilized, impact-resistant polyethylene with integral transmission tunnel.

The **Main** tank incorporates twin "main" lids, both fitted with a basket strainer. The larger (front) lid (see orange arrow) has a basket rinse function.



Filling the main tank can be via the basket or via a remote fill tap and camlock at the rear of the sprayer. The fill camlock can be seen on top of the sprayer. (see Green arrow).

The 130 Litre freshwater **Flushing** tank on the 2000 model is a separate tank integrated into the shape of the main tank at the front of the sprayer (see Red arrow). FRESH WATER ONLY



The 15 Litre **Hand-wash** tank is a separate integrated into the flushing tank at the top front left corner of the sprayer (see Blue arrow fill point), FRESH WATER ONLY. See tap outlet below.



The main tank has a two, calibrated level indication sight gauge tubes with floats. One at the front (right) side and another on the left side of the sprayer.

The main tank Drain is positioned near the step on the left-hand side of the sprayer.

Please dispose of any chemical in a safe and environmentally responsible manner.



SECTION 4

PRODUCT FEATURES / FAMILIARISATION

1500 XL MODEL

From 2021 onwards.

All tanks are constructed of UV stabilized, impact-resistant polyethylene.

The 1500 Lt, opaque white **Main** tank incorporates twin lids, both fitted with a basket strainer. The larger (front) lid has a basket rinse function. The tank includes an integral transmission tunnel.



Filling the main tank can be via the basket or via a remote fill tap and camlock at the top of the main tank.

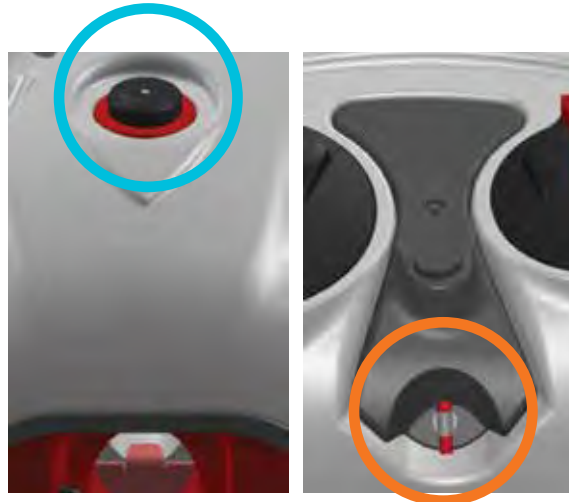

The red 120 Litre freshwater **Flushing** tank is located towards the front of the sprayer. The design is integrated with the main tank and transmission tunnel. (**blue circle** fill point). FRESH WATER ONLY.

The 15 Lt **Hand-wash** tank is located on the left side of the main tank, between the 2 main tank lids. See tap outlet (**orange circle**). FRESH WATER ONLY.

The main tank has a two, calibrated level indication sight gauge tubes with floats. One at the front (right) side, visible from the tractor cab, and another on the left side of the sprayer (as shown).

The main tank Drain is positioned near the step on the left-hand side of the sprayer – see **green circle**.

Please dispose of any chemical in a safe and environmentally responsible manner.

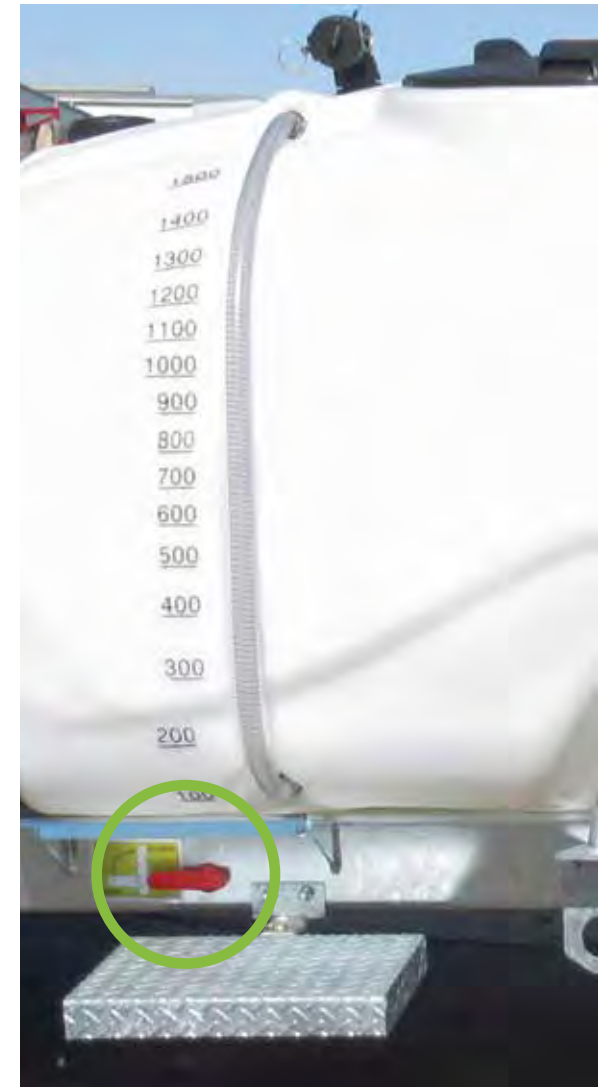

SECTION 4

PRODUCT FEATURES / FAMILIARISATION

PUMPS

The Annovi Reverberi (AR) range of reliable and robust diaphragm pumps have been industry leaders for more than 60 years and have partnered with Croplands for more than 40 years.

Croplands Cropliner sprayers use quality high-pressure pumps AR pumps.

The choice of standard pump will vary from model to model.

AR pumps come fitted with an identification label with extra information re ...

- Model number
- Serial number
- Maximum rpm
- Pressure and flow ratings
- Oil type



RPM MAX	bar	l/min	BHS 200	
550	0	193.7	Cod. 30774	
	50	183.3		
S/N 3077400		OP18006059	17180085	Pr. 235 OIL SAE 30
WWW.ANNOVIREVERBERI.IT				

ARBHS-200 (max. 50-bar) – large capacity (194 L/min) four diaphragm pump featuring front external bronze manifolds and brass heads to minimise corrosion. Fitted as standard on 5000 Litre Sprayer and optional on 2000, 3000 & 4000 Litre models for higher application rates.

ARBHS-170 (max. 50-bar) – large capacity (163 L/min) four diaphragm pump featuring front external bronze manifolds and brass heads to minimise corrosion. Fitted as standard on 2000, 3000 & 4000 Litre models.

ARBHA-140 (max. 50-bar) four diaphragm pump (142 L/min), cast anodised alloy. Fitted as standard on the 1500 litre model.

COMET IDS-2600 (max. 50-bar) 6 x diaphragm brass pump (249 L/min) is fitted (as an option) to the 5000 Litre model for higher application rates.

All pumps are supplied with a separate manufacturers manual.

PTO SHAFTS



The “product” pump is driven via a PTO shaft connection to the tractor.

Supplied is the heavy duty SH6-AG Series PTO driveshaft with safety covers and quick release pins. A separate manual is supplied with each shaft.

Optional SHCV60 (95hp) shaft should be used when operating the

1060 Fan at maximum blade pitch angle and speed.

Optional Wide Angle (CV) shafts available.

Refer Pre-Operations (section 5) re set-up of the PTO shaft between tractor and pump.

The Fieni fan is driven via a PTO through shaft connected from product pump to fan gearbox. Details of this shaft can be found in the Warranty booklet, specification page.



SECTION 4

PRODUCT FEATURES / FAMILIARISATION

SPRAY SYSTEM OVERVIEW

- A. Always ensure the Hand-wash tank is filled with fresh water before any other actions.
- B. Ideally fill the Flushing tank (if fitted) before filling the main tank.
- C. Fill the Main tank - preferably via the camlock fitting. Alternative method is via the main lid, but this is not recommended as the fill point is above the operators head.
 - Make sure the drain tap is closed before filling.
 - Always wear safety gloves.
- D. See Spray Operations (section 6) re adding chemical.

The liquid system will vary from model to model; however, the same basic design is followed



- E. Tank Selection Valve (photo E shows the valve in the off position). Always select off when cleaning the filter. Never select off when running the pump. Always turn off the pump before making a change.
- F. From the selection valve to the Suction Filter (see photo F), and onto the brass pump.



- G. The pump's pressure manifold supplies the main spray line, agitators, basket rinse and chemical probe (see next page);
To follow the main spray line
- H. Maximum spray pressure is set by the pressure regulator. Refer Spray Operations (section 6) for detailed instruction.



- I. From the pump manifold / regulator, to the Sprayer's Pressure manifold which comprises of 3 main parts, (1) Filter, (2) Flow Regulating Servo valve (5 second) and (3) Dump valve.

Note the photo is of a unit which is using an optional spray rate controller.

Refer Spray Operations (section 6) for detailed instruction.



Clean the Pressure Filter regularly. Clean at least daily or more often if the water source isn't clean, and whenever freshwater flushing.

SECTION 4

PRODUCT FEATURES / FAMILIARISATION

J. From the pressure manifold to the spray manifold which comprises of (1) Flow meter and (2) Section valves – in the photo below are 2 sections (refer pg 21) which supply the fan spray manifolds and nozzles.



The tap on the back of the pressure gauge is used to relieve sediment trapped in the gauge line. Use at least daily or more often if the water source isn't clean, and whenever freshwater flushing.

As per (G) on the previous page, the pump's pressure manifold also supplies the ...

1. Twin Supa-Flo Agitators (**Blue arrow**), (single for the 1500 model),
2. Basket Rinse (if fitted) – (**Yellow arrow**) and
3. Suction Probe (**Red arrow**).

Each of these has an on / off tap for activation as required.



K. The main pressure gauge is also connected to the spray manifold.

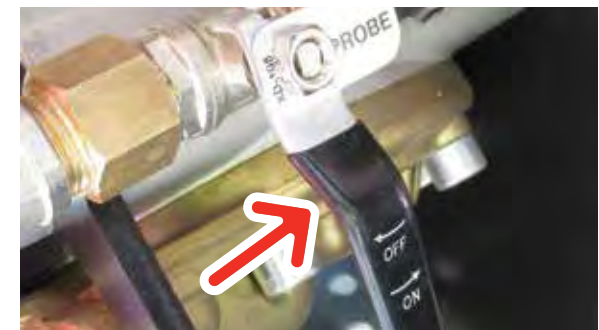

SECTION 4

PRODUCT FEATURES / FAMILIARISATION



The suction probe has two taps. The first is at the pump which activates the venturi system to create the suction, and the second tap allows the probe to be turned on / off or set to partially open as required.

Refer Spray Operations (section 6) re-adding chemical via the probe.

SECTION 4

PRODUCT FEATURES / FAMILIARISATION

CONTROLS

Spray Control Options:

1. Manual remote mounted ARBMH50 controller is the base model option.
2. Standard electrics - high pressure solenoid valves, 2-section in-cab control with electric pressure adjustment
3. Croplands HV2400 auto-rate controller
4. HV4000 automatic rate controller, 2-section (left/right) with optional 4-section control
5. Bravo 180S automatic rate controller, 2-section (left/right) with optional 4-section control

All electric / auto rate controllers come supplied with their own manual.

The supplied controller has already been tested before leaving the factory.

Manual controller, AR BMH-50

Functions include left/right shut-off, simultaneous shut-off, full bypass, pressurised bypass, manual pressure adjustment with pressure gauge.



Brass control unit with working pressure regulating valve, single lever for partial or total closure and discharge, glycerine bath pressure gauge with coloured dial.

- Must be mounted in a position which allows the operator easy access.
- All operations are controlled by a lever.
- Use knob to regulate working pressure: turn clockwise to increase pressure (+), counter-clockwise to decrease (-).
- Flush the control unit with water when you finish work to remove any internal deposits.

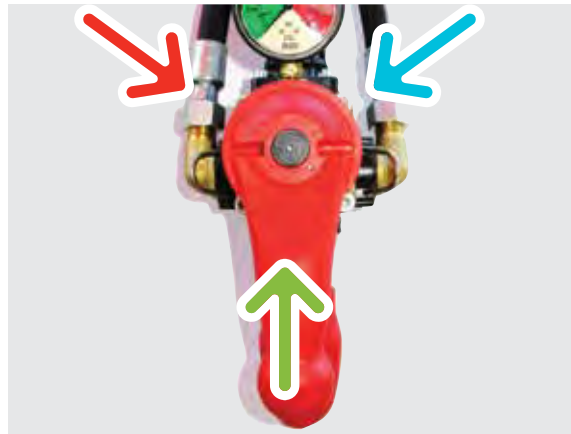

- **Blue Arrow** = Bypass
- **Green Arrow** = Boom selection (SX-DX), Left section only – All sections – Right section only
- **Red Arrow** = Closed / Pressure setting



Shown above in the bypass position. Photo to the far left is both booms on.

Refer to Sections 5 and 6 re using this controller.

SECTION 4

PRODUCT FEATURES / FAMILIARISATION

Option; Standard Electrics HT-IS4021

High pressure solenoid valves, 2-section in-cab control with electric pressure adjustment is in effect an electrical version of the manual controls.

Comes with an 8-page manual.



Electric in-cab controller with switchbox. 2-section high-pressure electric valves for individual left/right shut off, electric pressure regulating valve and a master on/off can all be operated from the switchbox in the cab. Requires a reliable 12V power supply.

All controls via the switchbox.

Refer to Sections 5 and 6 re using this controller.



Option; Croplands HV2400 auto-rate controller

A basic spray rate controller with 2-section solenoid control with up to 10 pre-set application rates. Programmable alarm settings with L/ha and L/100m capability.

Comes with a 48 page (3 part) manual.

Requires a reliable 12V power supply.



Refer to Sections 5 and 6 re using this controller.

Option; HV4000 automatic rate controller

2-section (left/right) with optional 4-section control of motor valves or solenoids. Pre-set row width and application rates for simple, on-the-go adjustments.

Comes with a 74 page manual.

Requires a reliable 12V power supply.

Multiple screen selections, programmable audio, and visual alarms and up to 10 individual operating histories to keep the operator informed.

L/ha or L/100m capability.

Fully integrated to NuPoint data management system.

Refer to Sections 5 and 6 re using this controller.



SECTION 4

PRODUCT FEATURES / FAMILIARISATION

Option; Bravo 180S automatic rate controller

For the operator requiring GPS integration and data transfer via USB.

Comes with a manual on CD.

Requires a reliable 12V power supply.

2-section (left/right) with optional 4-section control

Pre-set row width and application rates for simple, on-the-go adjustments. Multiple screen selections, programmable audio, and visual alarms and up to 10 individual operating histories to keep the operator informed.

L/ha or L/100m capability.

Fully integrated to NuPoint data management system.

Refer to Sections 5 and 6 re using this controller.



SECTION 5

PRE-OPERATION

SAFETY FIRST	42
HOOK UP	42
HOOK-UP HV4000 AUTO RATE CONTROLLER	46
HOOK-UP BRAVO 180S	48
HOOK-UP HV2400	48
HOOK UP MANUAL CONTROLLER	48
HOOK-UP BRAGLIA ELECTRIC CONTROLLER	49
FUNCTIONALITY CHECKS	50
SET-UP SPRAY PRESSURE	53
GENERAL NOTES ON AUTO-RATE CONTROLLERS	54
CONFIGURE THE FAN	55
PRE-OPERATION CHECKLIST	57

SECTION 5

PRE-OPERATION

From arrival on farm, hook up and prepare the sprayer for operation.

SAFETY FIRST



Before progressing further,

- Read and understand the Safety Manual (part no. GP-SAFE-A) supplied with this sprayer.
- Read and understand this manual to better familiarise yourself with the sprayer.
- Ensure the tractor to be used to tow this sprayer is fit for purpose (tow ratings etc...). If in doubt consult the tractor dealer/manual.



HOOK UP

The Cropliner Sprayer has been fully tested before leaving the Croplands factory. Some components will require further assembly after shipping from the factory/dealer;

1. Determine the correct position for hitch & PTO shaft & Shaft type.

2. Adjust drawbar lengths
3. Connect to the tractor
4. Add safety chains (if supplied)
5. Fit PTO
6. Connect controller and all other relevant connections to the tractor

Always park the sprayer in a horizontal position and on firm, level ground. Use wheel chock's if required.

On Standard PTO shafts, the drawbar pin connecting the tractor & Cropliner should be centred between the two universal joints of the PTO shaft. For wide angle (constant velocity) shafts, see alternative settings on page 42.

Once the sprayer is connected to the tractor always ensure the park stands are removed or folded to the horizontal position before moving.

Hitch & Standard PTO

When travelling straight ahead, the point at which the sprayer drawbar pin is joined to the tractor should be halfway between the universal joints of a Standard PTO shaft, as illustrated (A, B & C).

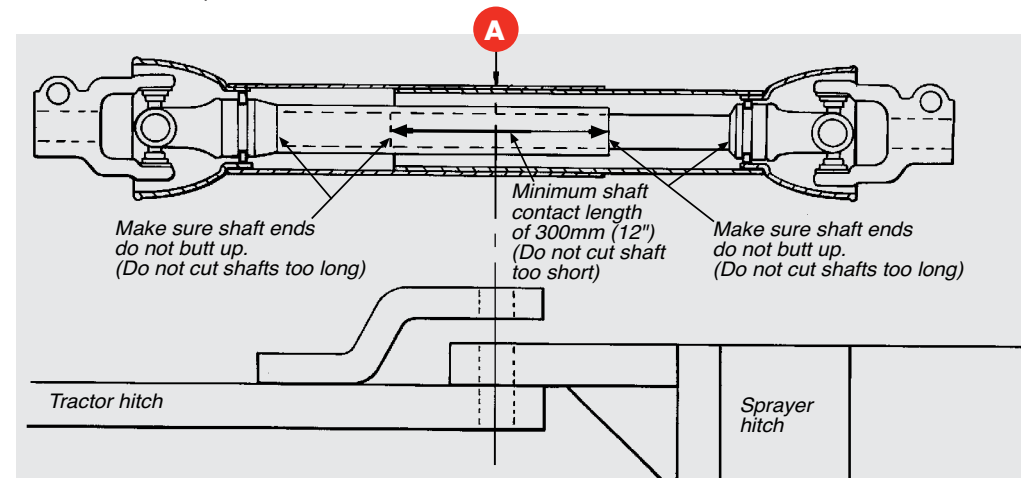

Maximum spine height difference 100mm (approx) for Standard PTO shafts

Drawbar pivot midway with standard PTO shafts

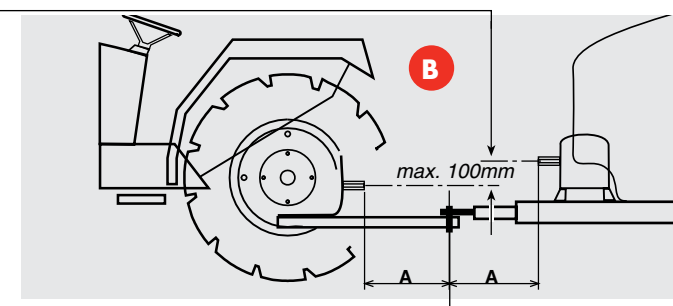

SECTION 5

PRE-OPERATION

This enables the tractor to make maximum turns with minimal bending of the universals.

Important:

- Do not allow more than 10% difference in the two halves of drawbar length. If more than 10% difference occurs, a wide-angle shaft must be used.
- The Standard PTO shaft is only recommended where the maximum intermittent turning angles do not exceed 45° turning angle of the PTO.

STANDARD PTO

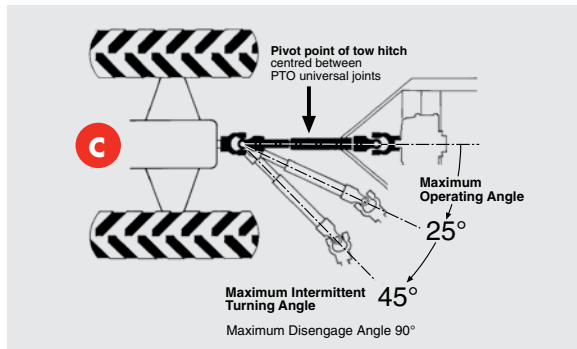

Important:

- Ensure that the drive shaft is the correct length to avoid it bottoming out & causing damage to the pump.
- When the tractor is towing the sprayer straight ahead, the two telescopic sections of the PTO shaft are at maximum extension.
- When turning or crossing an inversion, the telescopic shaft sections close up.

Hitch & Wide-Angle PTO

Optional Wide-Angle PTO Shaft

The Wide Angle (constant velocity) PTO must be used where tight turning requires greater than 45° turning angle of the PTO, as illustrated (D)

Where height variance between the tractor output spline and Cropliner input shaft is greater than 100mm, a wide angle (constant velocity) PTO must be used, as illustrated (E).

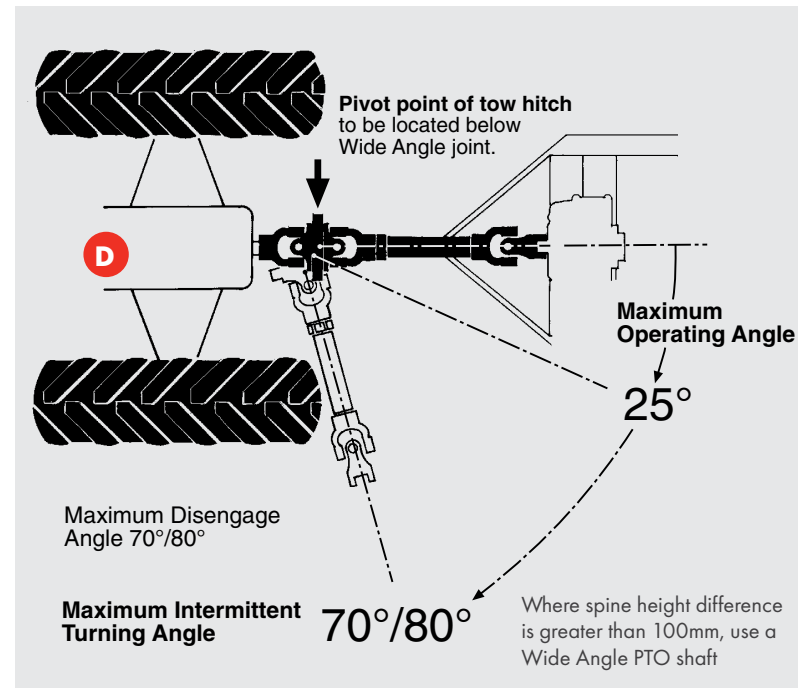

These shafts perform very differently when turning the tractor and sprayer at the end of rows. They must be set-up and operated within the limits outlined.

A Wide Angle (constant velocity) joint should always be positioned over the shortest half (ideally over the pivot point itself).

Refer page 45 re PTO installation.

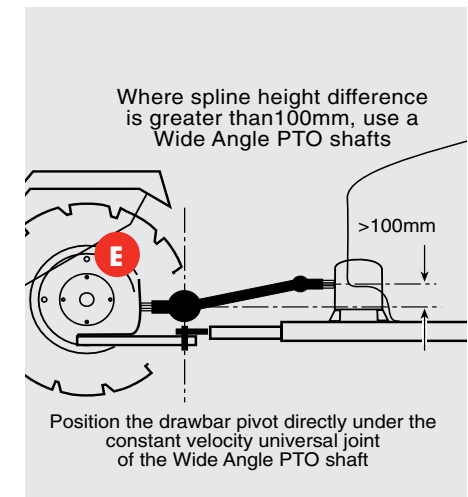

SECTION 5

PRE-OPERATION

DRAWBAR

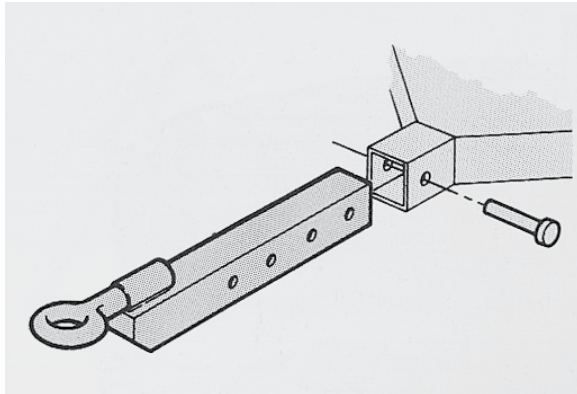

All Cropliner Sprayers are fitted standard with an adjustable length drawbar. It can be used with the tow eye on top or on the bottom.

To adjust the position of the Cropliner hitch:

- Make sure the Cropliner cannot roll and support the front of the chassis.
- Loosen the locking nut and bolt (on the corner) of the Cropliner hitch.



- Remove the nut and then the bolt that goes horizontally through the hitch
- Slide the hitch in or out of the Cropliner frame to the length required
- Replace and tighten the through bolt locking nut.

CONNECT SPRAYER TO THE TRACTOR

Align drawbars of tractor and Cropliner, then insert & lock the drawbar pin in position ensuring it cannot come out while transporting or operating.

Lift up and/or remove the park stands for sprayer operation.

Check the Cropliner is level fore and aft. The sprayer should be slightly lower at the front. If not make the necessary adjustments to tractor and/or sprayer drawbars and axle to achieve level position.



Optional Self-Tracking Drawbar

The self-tracking drawbar can be used where tight turning requires greater than 45°.

It is also suitable for ensuring the sprayer wheels track on the same lines as those of the tractor to make row exit & entry easier.

Note this is not a standard option. It is shown here for reference only.

Must use wide angle PTO shaft (unlike the shaft shown here).



Ensure the pivot points are greased regularly (every spray-round).

To adjust the self-tracking drawbar length, follow the steps as for the standard drawbar hitch.

SECTION 5

PRE-OPERATION

SAFETY CHAINS

If supplied, install the safety chain(s).



FIT THE PTO SHAFT

A new standard-length PTO shaft is supplied with the sprayer. In most cases this will require cutting to a shorter length - specific to the tractor & sprayer dimensions.

Follow the instructions below to fit the PTO shaft onto the Cropliner™ after transit.

Note for new installations, the dealer will oversee the fitting of the new shaft.

Also, refer to the user manual that is supplied with every new PTO shaft.



- Remove the PTO shaft which is usually delivered strapped to the Cropliner™. Check the PTO shaft has not been damaged in transit

- Grease the universal joints, telescoping shafts & safety cover bushes
- Measure and fit the PTO to the sprayer ensuring the locking pin is correctly located.
- Cutting the PTO shaft to length requires knowledge of this procedure. If you have not carried out this procedure before, ensure your dealer carries out this important step.
- If the Cropliner is hitched too closely, remove excess PTO shaft to avoid bottoming out that will cause additional damage.



Before operating the drive shaft, be sure that all safety guards are in place & safety chains are securely fitted (refer to PTO User Manual).

Do not exceed the maximum RPM of the pump or gearbox (540 RPM).



Incorrect hitching of PTO shaft will result in excessive pump vibration.

Note: Failure to fit or operate the PTO as instructed can result in serious damage to the pump, PTO and any components connected to the drive train of the tractor and Cropliner. Incorrect operating will void warranty claims.

SECTION 5

PRE-OPERATION

HOOK-UP HV4000 AUTO RATE CONTROLLER

If ordered.

The controller has been fitted and adjusted at the factory but has been disconnected and packed for transit, along with the required power/connection looms and in cab RAM mount.

Connect the main loom. Find a suitable position external of the cab for the 24 pin plug connection. It's recommended that the connection be orientated as per photo right, with the cable entry on the bottom side (to help prevent water ingress).

Normally this connection is positioned behind and external of the cab/somewhere near the hydraulic remotes. Route the loom into the cab and find the best position for the controller with the remaining length of the harness.



Fit the controller/console into the tractor cab in a convenient & safe location for the operator.

Ensure the wiring cannot interfere with the PTO shaft or any tractor functions.

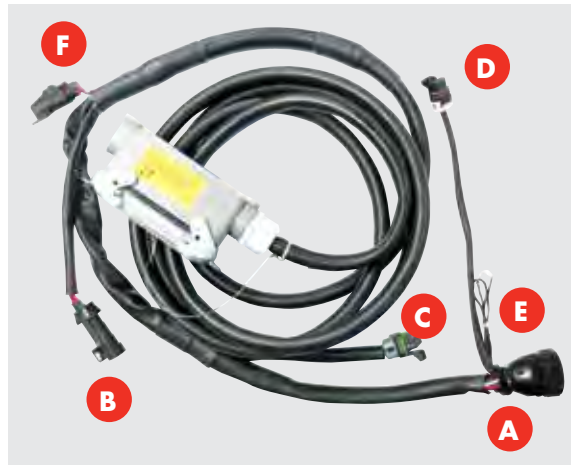
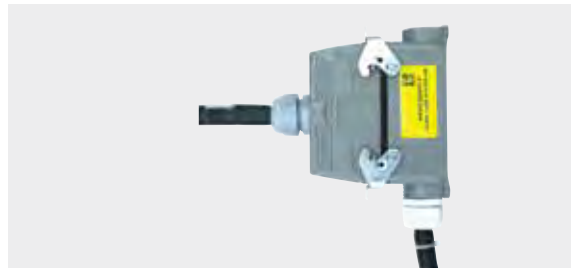

The connection loom features

- A. Connection to the HV4000 controller
- B. Power connection

- C. The "green" 5 pin connector is not used for Cropliner models
- D. Speed - GPS (or can be any speed via pulse)
- E. Earthing lead – not generally used
- F. Fuse, 10 amps

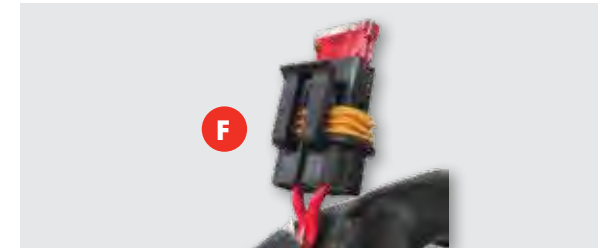

- A. Connection to the HV4000 console via Con port 2. Refer to photo 1. Be careful to correctly align the pins before tightening.



photo 1

SECTION 5

PRE-OPERATION

B. Power connection requires a connection to the power loom (supplied). Refer to photo 2.

It's highly recommended the power loom(s) are hard-wired at the tractor battery rather than hooking up to cab connections. Only qualified persons should assemble/disassemble or service electrical components. The fuse is 10 amps.



photo 2



photo 4

D. The "purple" 3 pin connector is used when GPS speed or an extra speed-related connection (pump speed etc) is required.

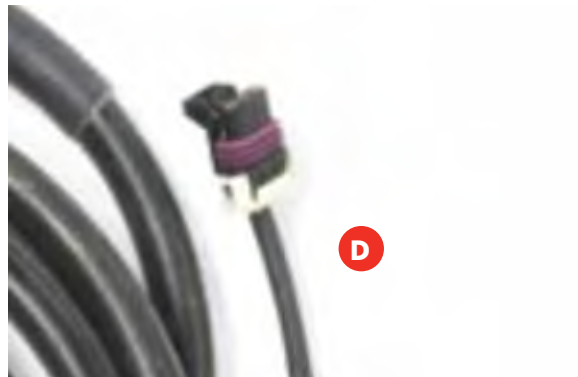

photo 3

Supplied with each HV4000 is a "RAM" Mount. This will normally be fitted by the tractor dealer as a part of the installation process.



HOOK-UP BRAVO 180S

Connecting the Bravo 180S is similar to the HV4000 at the sprayer end – with different connections at the cab and controller.

It's highly recommended the power loom(s) are hard-wired at the tractor battery rather than hooking up to cab connections. Only qualified persons should assemble/disassemble or service electrical components. The fuse is 10 amps.

Ensure the wiring cannot interfere with the PTO shaft or any tractor functions.



SECTION 5

PRE-OPERATION

HOOK-UP HV2400

For sprayers fitted with the optional HV2400 basic 2 section spray-rate controller.

The controller has been fitted and adjusted at the factory but has been disconnected and packed for transit.

Follow the controller's manual for instructions on connecting to a suitable (tractor battery) power source.

Find a suitable position on the tractor / within the cab for the control switchbox.

Connect the supplied control / switch to the tractor and sprayer ...

1. Connect to a suitable (tractor) power source
2. Connect to the controller manifold loom

Take care to route the wiring looms away from PTO shafts, linkage arms etc.



HOOK UP MANUAL CONTROLLER

The standard manual controller, if fitted, AR BMH-50, has been run and adjusted at the factory.

Mount the manual controller in a suitable position, external of the cab (should never have pressure lines within a tractor cab), but within easy reach of the main control arm and easy reading of the pressure gauge.

Ensure all hoses are free of linkage arms, PTO shafts etc.



HOOK-UP BRAGLIA ELECTRIC CONTROLLER

For sprayers fitted with the optional Braglia I-S4021 electric (in-cab) controller / pressure manifold.

The controller has been fitted and adjusted at the factory but has been disconnected and packed for transit.

Follow the controller's manual for instructions on connecting to a suitable (tractor) power source.

Find a suitable position on the tractor / within the cab for the control switchbox.

Connect the supplied control / switch to the tractor and sprayer ...

1. Connect to a suitable (tractor battery) power source
2. Connect to the controller manifold loom

Take care to route the wiring looms away from PTO shafts, linkage arms etc.

SECTION 5

PRE-OPERATION



The control box unit has switch functions for ...

1. 3 position master on / off / off switch
2. 2 x section control on / off switches
3. pressure control toggle switch.

Set-up

Before start-up make sure all switches are in the off position. Engage PTO at low speed.



The master switch has 2 off positions.

The fully down OFF position (shown above) will draw power (light is on). The bypass (dump) valve is open and there will be no pressure.

The middle OFF position will draw no power, the pressure relief valve is active. With the PTO running, the pressure will show on the gauge.

Adjust the pressure via the toggle switch on the right-hand side of the control box.



The up position is ON. To activate spraying, flick either or both spray section switches to ON. Adjust the pressure to suit.

Always finish with the master switch in the middle position (to avoid a flat battery).

SECTION 5

PRE-OPERATION

FUNCTIONALITY CHECKS

With the hook up completed, the functions need to be tested before using the sprayer with chemicals. Also refer to the Pre-operation checklist at the end of this chapter on page 55.

It's advised that a freshwater test be done to check for leaks and to familiarise the operator(s) with the sprayer and set the sprayer to maximise results in the field.

These checks have been conducted in the factory prior to shipping, however, there is a chance that transit could have loosened some fittings.

Before progressing further,



- Read and understand the Safety Manual.
- Read and understand this manual, and the operator is familiar with all controls.

1. Check that the sprayer is correctly hooked up to the (suitable) tractor. Jockey wheel or park stand is properly stowed or removed.
2. Check the sprayer wheel nuts (normally M18 / minimum torque setting of 344 Nm)



3. Check tyres for correct pressure and are even on both sides.
All tyres will have maximum rating listed on the tyre sidewall. From the factory, sprayers are delivered with 40 ~ 50 psi in each tyre (will vary from model to model).
4. Check PTO and fan guards are in place. **NEVER** operate with exposed PTO or Fan.



5. Spray controller correctly connected and powered.
6. Check pump oil levels and surge chamber pressure - air pressure should be 20 ~ 25% of operating pressure levels (refer pump manual for more detail).



7. Check that all fittings are tight, nothing is loose or damaged.
8. Double check for loose objects in the vicinity of the Airblast fan. Ask any onlookers to keep a safe distance away.
9. Check for wear and tear on all chemical and hydraulic hoses and wiring looms.
10. Ensure fill, suction & pressure filters are clean. Be safety aware as some spillage is likely.



11. Ensure the tank drain valve is in the closed position.



SECTION 5

PRE-OPERATION

12. Add sufficient clean fresh water to all the tanks (see section 4 for tank details). Ensure the water level is above both agitators in the main tank.
13. Select the spray pump's water source to be the main tank / SPRAY.



14. Make sure the Fan (gearbox) is in the middle / neutral position (see page 18), and nozzles are on.

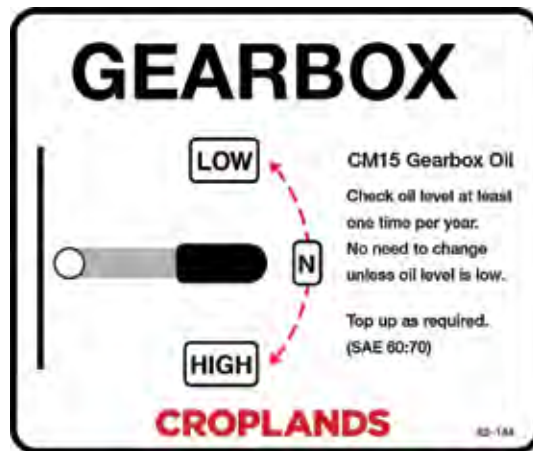

15. The pump pressure manifold will have taps for AGITATION, BASKET (rinse) and PROBE. Turn all of these to the OFF position. These will be checked once the system is pressurised.

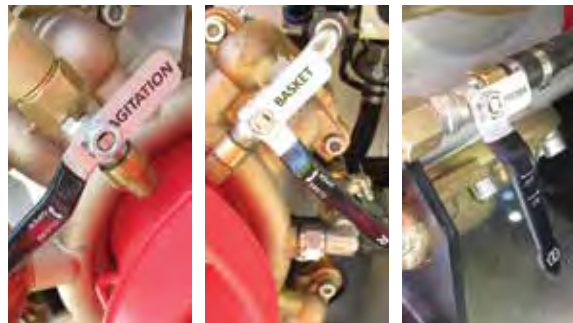

16. Ensure all spray function controls are in the OFF / bypass position.
This will vary depending upon the controller used.

For the manual controller, set to the BYPASS position.



For the Braglia Electric controller, before start-up make sure all switches are in the off position.



The master switch has 2 off positions. The fully down OFF position (shown above) will draw power (light is on). The bypass (dump) valve is open and there will be no pressure.

The middle OFF position will draw no power, the pressure relief valve is active. With the PTO running, the pressure will show on the gauge.



Note: Re this controller, always finish with the master switch in the middle off position (to avoid a flat battery).

SECTION 5

PRE-OPERATION

For the **HV2400**, **HV4000** or **Bravo 180S** auto rate controllers, follow the controller instructions / operator's manual set them to "HOLD". This will open the servo "dump" valve to tank.



17. Power up the tractor (brakes on) and engage the PTO - no need for full power at this stage, set to approximately 350rpm.
18. At this stage the pump will be drawing from the main tank and bypassing (dumping at) the pressure regulator back to the tank via the return hose.
19. Activate the spray controls, to confirm the spraying functionality. This operation will vary depending upon the controller used. See the appropriate manuals (for electric / auto rate controllers) and following instructions for operation of the manual controller and setting system pressures.

The following pictures show the HV2400, HV4000 and Bravo 180S controllers in "run" mode.

At this stage the Fieni fan is not operating.

While water is being pumped / sprayed through left, right, and then both sets of nozzle manifolds check for any leakages or blockages throughout the sprayer.

Check hoses, connections, valves, filters, boom fittings etc. Also check nozzles are operating correctly and that roll-overs are aligned and working correctly. Rectify any problems.



SECTION 5

PRE-OPERATION



20. Check the operation of AGITATION, BASKET (rinse) and PROBE functions. Leave the agitators ON whilst performing the final checks.
21. Once operation at lower speeds and pressures is confirmed, slowly increase operating (PTO) speeds until the maximum of 540 rpm is achieved. Re-check functions and hose connections etc.
22. On the completion of these tests, turn off the spray functions and bring the PTO back to low speed.
23. Confirm fan operation. With low PTO speed (tractor must be above idle), engage the Fieni fan into low gear (normally this is lever up / refer page 18).

Best practice is to always change or disengage or change gears at low fan speed.

CAUTION – make sure the area around the fan is clear of bystanders and the fan air intake is free of debris.

24. Confirm smooth operation throughout the complete speed range up to full speed (PTO = 540 rpm).
25. Repeat at the higher speed gear setting.
26. With the fan operating, turn on the spray functions and confirm all systems are operating.
27. On completion of checking the sprayer turn controls off by placing the master switch and boom switches in the off position. Disengage the PTO after the spray controls are turned off.
28. Final checks & clean filters, including the “boom” filters at the rear of the sprayer



SET-UP SPRAY PRESSURE

Note: The Fieni fan does not have to be engaged during this process

Croplands recommends setting the maximum system pressure to be 10% above the chosen spray pressure which

is normally an extra 1.0 – 1.5 bar.

If fitted with a spray rate controller, the auto rate controller will make automatic pressure adjustments to control rate.

All systems (except the electric Braglia I-S4021) will have a manual adjustable available for setting the system’s maximum pressure.

The regulator will need to be adjusted from time to time as spray rates will vary throughout the year.

WARNING: To set and forget at a high pressure will put undue stress/wear and tear on the system. Maximum recommended pressure is 20 bar, but 10 ~ 15 bar is the normal recommendation.

To set PRESSURE for the first time:

- Ensure that the nozzles fitted on the sprayer are applicable to your desired rate & recommended operating pressure.
- Ensure the tank selection valve is in the SPRAY position.



- Wind the pressure control knob anticlockwise to ensure the sprayer starts up with limited pressure
- Start the tractor & ensure the electric control box or auto rate controller (if fitted) is turned ON.
- Start the pump by engaging the Tractor PTO. Set to operate at your required rpm, usually between 450 and 540 rpm

SECTION 5

PRE-OPERATION



- Engage both Front and rear Agitators
- Activate spraying via the fitted (be it manual or auto rate



controller), with the required spray rates and with all relevant sections open.

- Wait 10 seconds to allow the system to settle, then
- Slowly wind the pressure control knob clockwise (if needing to increase pressure) until your required operating pressure is reached and add a further 10% surplus pressure.
- Example - If the application rate is 500 L/ha and with

your row width/nozzles & spraying speed the rate is achieved at 10 bar, you would set the maximum system pressure to 11 bar.

- Once done, leave the manifold setting "as is" until a change of operating pressure is required.

GENERAL NOTES ON AUTO-RATE CONTROLLERS

Function of Auto-rate Spray Controllers.

If your Cropliner is fitted with either a Bravo 180S, HV4000 or HV2400 controller, you will have available to you a lot of additional functions & features.



An auto-rate controller, regardless of manufacturer, uses on-the-go inputs to determine the spray rate being applied at that moment in time.

It is designed to adjust an electric bypass valve (usually referred to as the "Servo" valve) to either return excess flow

SECTION 5

PRE-OPERATION

to the tank, or force more liquid out the nozzles & therefore onto the crop/canopy you are spraying.

The servo valve, along with the inputs of flow & speed, are the components most likely to give problems if they are not working correctly. To identify where a problem exists with a controller, performing a pre-field check by operating the controller in manual mode will often provide the answer.

Inputs

The auto-rate controller requires a speed input from a wheel sensor, and a flow input from a flowmeter. Using this information, along with row width data, the controller can display the actual flow rate in litres per 100 metres or in litres per hectare, depending on your choice of application monitoring.

Functions

If the speed of the tractor changes, the controller senses the change & sends power to the servo valve to either open or close the servo valve. If the tractor slows down, the servo will open to allow more flow to return to the tank, thereby reducing the flow to the nozzles.

Liquid will always take the easiest path, and as the servo bypass line is unrestricted to the tank, the liquid will bypass rather than flow out of the nozzles.

Conversely, if the tractor speeds up, the servo will close and force a lift in pressure, ensuring the liquid must pass through the nozzles, which in turn ensures the spray rate to the crop/canopy is maintained.

The flowmeter sends information to the controller at the same

time as the speed input, ensuring that when the correct flow to match the determined spray rate is reached, the servo "locks on" to that position and maintains the required rate.

Common faults

If the controller does not receive the flow input, speed input, or if the servo cannot function, the controller cannot reach its programmed spray rate or shuts down altogether. These three faults are the most common cause of problems.

Another problem that can occur is when the nozzles installed on the sprayer cannot work within the parameters you have asked the controller to work within.

Simply put, if the nozzles are too small or too large to attain your pre-set spray rate, the controller cannot deliver or bypass sufficient liquid to function.

Pre-field check

By testing the controller in manual mode, we can determine if it is (a) correctly set up so it will perform properly in auto mode, and (b) find out where a problem exists if the controller is not functioning correctly.

The Bravo 180S, HV4000 or HV2400 can be set to MANUAL (or MAN) mode by pressing the appropriate key on the console. (refer to the controller manual to identify key functions).

Once in MANUAL mode, the sprayer can be operated in a stationary position, and the operator can take control of the servo valve.

In **Manual** mode, with the PTO running & liquid spraying out of the nozzles, the "+" & "-" keys (or ▲&▼ keys) will manually open and close the servo.

By performing this function, the operator can observe the pressure on the sprayer gauge, and the flow on the console readout to see if this matches the desired pressure & flow to achieve the desired spray rate.

This test also determines if the servo is working correctly, and if the flowmeter is registering the correct liquid output or if there is in fact no flow showing (indicating a faulty sensor or flowmeter). This step is important for troubleshooting.

By increasing the flow & pressure with the "+" & "-" keys (or ▲&▼ keys), the operator can also check that the manual regulating/pressure relief valve is set in the right position to allow correct flow for the system.

If the manual PRV (pressure regulating valve) is not set right, the pressure or flow your nozzles require may not get to the desired level if the PRV is allowing too much liquid to bypass.

Likewise, if the PRV is adjusted too tightly, the servo may not be able to bypass enough liquid when fully open, resulting in over-application.

By opening and closing the servo in manual mode with the "+" & "-" keys (or & keys), the range of pressure & flow can be checked.

As a rule of thumb, you should close the servo fully (hold the "+" or ▲key until maximum pressure/flow is reached).

If this is not what you require to achieve your upper level, then adjust the PRV by turning it clockwise. If the upper level is too high in pressure or flow, turn the PRV anticlockwise until your upper limit of pressure or flow is reached.

SECTION 5

PRE-OPERATION

Then press the “—” or ▼ key to check the controller can reach an acceptable low level of flow/pressure - this will ensure in auto mode that the servo can bypass adequate liquid when the tractor slows right down.

Lastly, check the speed input by simply driving the unit along and ensuring a speed input is being logged by the controller.

If the controller works in Manual mode, it should operate perfectly in Auto-mode provided calibration data is correct and a speed input is being received.

These notes are a general explanation of the system functions of the Bravo 180S, HV4000 or HV2400.

For more detailed information, consult your operator’s manual for the controller, or your service agent or dealer.

CONFIGURE THE FAN

It is recommended that the setting up of the Cropliner fan fan speeds, vane and nozzle positions etc should be done in conjunction with a qualified specialist. (Croplands dealer, Croplands Representative, Agronomist or Spray manager).

The optimum set-up will vary significantly from vineyard / orchard to vineyard / orchard & stage of canopy growth.

Nozzle Choice

Check and / or fit the chosen nozzles to the unit.

Refer to section 7 for nozzle layout details.

For more information on nozzle availability, refer to the Croplands Buyers Guide nozzle section or the Nufarm SprayWise Hort book. Also refer p.83.



NOZZLE SELECTION												
DISCS & CORES												
NOZZLES - DISCS AND CORES												
NOZZLE	TYPE AND DESCRIPTION		SAMPLE ORDER CODE		TYPE	SIZE RANGE, MATERIAL		\$ (EX. GST)	\$ (INC. GST)	PROD. CAT.		
	Disc and Core Jets:		AZ-AD*		Disc	• 1 to 7				C		
	• Full and hollow cone spray patterns					• Pink ceramic						
	• Medium to fine droplets for use in ar associated situations		AZ-AC**		Core	• 13 to 56				C		
	• 5-20 bar recommended range					• Pink ceramic						
DISC AND CORE ALBUZ CERAMIC - FLOW RATES												
DISC SIZE	CORE SIZE	ORIFICE DIAMETER	L/MIN								ANGLES	
			3 BAR	4 BAR	5 BAR	6 BAR	10 BAR	15 BAR	20 BAR	10 BAR	20 BAR	
AD 1	AC 3	0.8	0.24	0.27	0.3	0.33	0.41	0.49	0.56	70°	79°	
AD 2	AC 13	1.02	0.31	0.35	0.39	0.42	0.51	0.61	0.71	67°	82°	
AD 3	AC 13	1.2	0.38	0.41	0.45	0.49	0.61	0.74	0.84	69°	86°	
AD 4	AC 13	1.56	0.45	0.52	0.57	0.62	0.78	0.95	1.06	69°	103°	
AD 5	AC 13	2	0.55	0.62	0.69	0.75	0.94	1.13	1.29	102°	105°	
AD 1	AC 23	0.8	0.28	0.32	0.35	0.38	0.48	0.57	0.65	68°	74°	
AD 2	AC 23	1.02	0.37	0.43	0.47	0.51	0.64	0.77	0.88	83°	90°	
AD 3	AC 23	1.2	0.44	0.51	0.56	0.61	0.76	0.92	1.04	84°	92°	
AD 4	AC 23	1.56	0.56	0.64	0.71	0.77	0.97	1.16	1.32	92°	98°	
AD 5	AC 23	2	0.72	0.82	0.91	0.98	1.24	1.48	1.7	96°	99°	
AD 6	AC 23	2.4	0.85	0.97	1.07	1.16	1.46	1.75	2	99°	101°	
AD 1	AC 25	0.8	0.41	0.46	0.51	0.55	0.7	0.84	0.95	59°	60°	
AD 2	AC 25	1.02	0.59	0.67	0.74	0.8	1.01	1.21	1.38	53°	60°	
AD 3	AC 25	1.2	0.72	0.81	0.9	0.98	1.23	1.48	1.68	63°	69°	
AD 4	AC 25	1.56	1.02	1.16	1.28	1.39	1.75	2.1	2.39	75°	80°	
AD 5	AC 25	2	1.41	1.6	1.77	1.92	2.42	2.9	3.3	72°	80°	
AD 6	AC 25	2.4	1.73	1.97	2.18	2.37	2.98	3.57	4.07	62°	85°	
AD 7	AC 25	2.8	2.07	2.36	2.61	2.83	3.57	4.28	4.97	80°	91°	
AD 1	AC 45	0.8	0.48	0.55	0.61	0.66	0.83	1	1.14	52°	58°	
AD 2	AC 45	1.05	0.71	0.83	0.93	1	1.24	1.51	1.71	48°	61°	

SECTION 5

PRE-OPERATION

Swing-Over Nozzles

Adjust the fitted non-drip roll-over nozzles according to your calibration and spraying requirements (also refer to Section 7).

The non-drip valve must be pointing in the direction of liquid flow.

The nozzles bodies are the twin roll-over type enabling one of two different nozzles to be selected.

Pictured are an ATR nozzle (yellow) or (grey) disk and core. Off is in the horizontal position, as per photo bottom right.



Fieni 820 ~ 920 DSV Fan, as factory fitted "standard", Albus ATR Hollow Cone Nozzles.
 Note customer can nominate an alternative nozzle configuration at time of order.

◀ Front Spray Ring				Rear Spray Ring			
Nozzle	ALBUZ Hollow Cone	Discharge	Spray angle	Nozzle	ALBUZ Hollow Cone	Discharge	Spray angle
Top 1	AZ-ATR-YW-80C	1.03	80 deg	Top 8	AZ-ATR-YW-80C	1.03	80 deg
2	AZ-ATR-YW-80C	1.03	80 deg	9	AZ-ATR-YW-80C	1.03	80 deg
3	AZ-ATR-YW-80C	1.03	80 deg	10	AZ-ATR-YW-80C	1.03	80 deg
Middle 4	AZ-ATR-YW-80C	1.03	80 deg	Middle 11	AZ-ATR-YW-80C	1.03	80 deg
5	AZ-ATR-YW-80C	1.03	80 deg	12	AZ-ATR-YW-80C	1.03	80 deg
6	AZ-ATR-YW-80C	1.03	80 deg	13	AZ-ATR-YW-80C	1.03	80 deg
Bottom 7	AZ-ATR-YW-80C	1.03	80 deg	Bottom 14	AZ-ATR-YW-80C	1.03	80 deg
		one side =	7.21			one side =	7.21
10 Bar	Pressure	14.42	L/min FRONT Spray Ring	28.84	L/Min ALL NOZZLES	14.42	L/min REAR Spray Ring



Record Keeping

Record the nozzle configuration in the Calibration Worksheet (refer Section 7 for more details), or other prescribed record keeping method.

SECTION 5

PRE-OPERATION

PRE-OPERATION CHECKLIST

Before operating the sprayer, please check the following items.



All chemical & safety guides have been read, understood and acted upon.
Operator is familiar with all control functions.
Secure sprayer connected to the tractor – jockey wheels or park stands are stowed away.
Wheel nuts (M18) checked for correct torque.
<div data-bbox="280 786 748 946" data-label="Image"> </div> <div data-bbox="280 962 748 1273" data-label="Image"> </div>
Check tyre pressures are even on both sides. All tyres will have maximum rating listed on the tyre sidewall. From the factory, sprayers are delivered with 40 ~ 50 psi in each wheel (will vary from model to model).

PTO connected, greased and safety guards correctly installed.
Spray controller correctly connected and operational.
<div data-bbox="922 673 1402 1102" data-label="Image"> </div>
Check pump(s) oil levels.
Confirm the spray pump operation.
Manual pressure regulator is set.
Check for wear and tear on all chemical and hydraulic hoses and wiring looms.

Ensure fill, suction & pressure filters are clean. Be safety aware as some spillage is likely.
<div data-bbox="1563 552 2074 903" data-label="Image"> </div>
Check that nothing is loose or damaged.
Check the alignment of all fans, vanes etc.
Check fan intake is free of leaves and loose objects.
Check that all tanks and spray lines are clean and empty, and the drain tap is closed.
<div data-bbox="1563 1169 1962 1425" data-label="Image"> </div>

SECTION 6

SPRAY OPERATIONS

EMERGENCY ACTION PLAN

Never operate the sprayer without an action plan in place for when things go wrong ...

“Take 5” to evaluate the risks

Actions for most foreseeable machine issues such as breakages start with ...

“Drop the speed”

“Dump the pressure”

then evaluate further.

SAFETY FIRST	60
FILTERS	60
FILLING THE SPRAYER	62
AGITATION	63
MIXING BASKET	63
CHEMICAL SUCTION PROBE	64
CALCULATE WATER & CHEMICAL QUANTITIES	65
PROCEED TO SPRAY	66
DRAIN & FLUSHING	66
TANK CLEANING	68
UNHITCHING THE SPRAYER FROM THE TRACTOR	69

SECTION 6

SPRAY OPERATIONS

The pre-operation and familiarisation tasks must be completed before commencing spray-operations.

Also, refer to the familiarisation section, pages 16-40.

SAFETY FIRST



Before progressing further,

- Read and understand the Safety Manual (part no. GP-SAFE-A) supplied with this sprayer.
- Read and understand this manual to better understand the sprayer.

FILTERS

Filters will ensure that no solids enter the system to block or damage pump or spray nozzles.

- Always ensure the basket filter is in place when filling the main tank.
- All filters should be cleaned regularly, or after each spraying period. Wear protective clothing.
- If the filter screen is damaged, replace it with a new screen.

Cleaning the suction filter (1500 ~ 4000 models)

The suction filter should be cleaned regularly or after each spray tank has been emptied.

To clean the filter:

- **Always wear safety gloves**
- Completely stop all sprayer functions.



- Place the Tank Selection Valve in the closed position to shut OFF liquid from the main tank.
- Remove the outer filter screw and bowl, and then remove the filter and thoroughly clean it.
- Some spillage is likely, therefore perform this operation in an appropriate place, and with safety clothing.

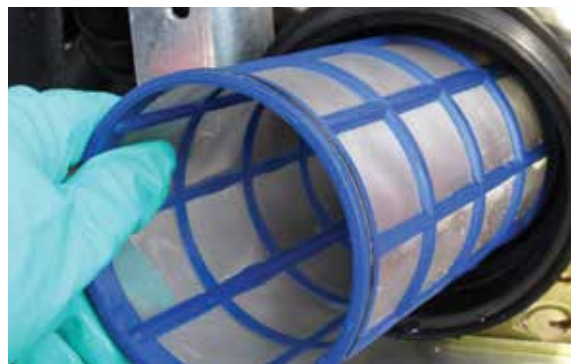

- Check the condition of the O-Ring before reassembling the filter.
- Remember to turn the ball valve back to SPRAY or FLUSH when finished.

Cleaning the Suction Filter (5000 model)

The pressure line filter should be cleaned regularly or after each spray tank has been emptied.

To clean the filter:

- **Always wear safety gloves**
- Completely stop all sprayer functions.



- Place the Fill valve in the OFF position to shut off liquid from the main tank.
- Remove the outer filter screw and bowl, and then remove the filter and thoroughly clean it.
- Some spillage is likely, therefore perform this operation in an appropriate place, and with safety clothing. Stand well clear of spillage zone.
- Check the condition of the O-Ring before reassembling the filter.

SECTION 6

SPRAY OPERATIONS



- Remember to turn the ball valve back to SPRAY when finished.

Cleaning the Pressure Filters

The pressure line filter should be cleaned regularly or after each spray tank has been emptied.

To clean the pressure spray manifold filter:

- **Always wear gloves**
- Some spillage is possible, therefore perform this operation in an appropriate place, and with safety clothing.
- Completely stop all sprayer functions.
- Remove the outer filter bowl, and then remove the filter and thoroughly clean the filter before re-assembly.

To clean the boom in-line filters (if fitted);

Opening the red tap at the bottom of the filter will drain any captured impurities to ground. Close the tap before continuing.



CAUTION

Always follow chemical label safety instructions. When handling chemicals always wear protective clothing ie. gloves, face mask, spray suit. Should chemical come in contact with skin immediately rinse off with water.

SECTION 6

SPRAY OPERATIONS

FILLING THE SPRAYER

Sprayer must be connected to the tractor before filling tanks, tractor hand brake must be on and chock the sprayer wheels.



Use freshwater (preferably rainwater), free of suspended organic matter or clay as some chemicals are de-activated when they contact these materials. Ensure sufficient water quantity to allow correct product blending.

Main Tank

When filling the main tank (freshwater only), open the spray tank lid and fill the tank with the basket filter in place. Clean the basket and replace the lid after filling.

Or ...

Fill via the separate Camlock fill (freshwater or chemical premix) – refer to pages 26 - 32. Connect to the water source before opening the ball valve (if fitted, as shown).



Some operators prefer to fill from a premixed tank, others will prefer to add powders via the basket or concentrate chemical via the probe to a fully or partially filled main tank.

Flushing Tank

Use FRESH WATER ONLY (preferably rainwater) in the flushing tank. Unscrew the lid and fill before spraying. Replace the lid after filling.

For more information re flush tank positions across the range see Section 4, pages 26 - 32.



Hand-wash Tank

Fill the hand-wash tank with FRESHWATER ONLY from a source remote to any chemical source. Replace the lid after filling.

Always maintain the correct caution label at the fill point.

For more information on the tank positions across the range see Section 4, pages 26 - 32.



SECTION 6

SPRAY OPERATIONS

AGITATION

When chemical is added to the tank, the pump and agitator(s) must be operating at all times to ensure chemical does not settle in the tank.

- Check the Tank Selection valve (located at the front of the sprayer) is open to SPRAY.
- Start the tractor.
- Start the pump by engaging the Tractor PTO. Set to operate at your required rpm, usually between 450 and 540 rpm.
- Turn ON the Agitator tap (assuming some liquid is in the tank). Shown here in the OFF position.
- Check that tank agitators are working.
- If agitation causes too much foaming in the tank, turn off one or both agitators, and monitor.
- If chemical settles, through pump break down or other reasons, start up the sprayer after the fault has been rectified, then let the mixture in the tank agitate for a length of time to ensure thorough mixing of the chemical.



MIXING BASKET

A separate chemical mixing basket is provided in the main tank to allow the operator to add and mix chemicals to the main tank while it is filling.

To operate the mixing basket:

- Fill the main tank with the appropriate amount of water
- **Always wear safety gloves**
- Measure the chemical required for the tank mix and place the chemical (liquid, powder or granules) into the mixing basket & close the mixer lid. This process is best done in several smaller batches of chemical.



- Check the Tank Selection valve (located at the front of the sprayer) is open to SPRAY.
- Start the Tractor.
- Make sure the electric or auto rate controller is NOT in Spray mode.
- Start the pump by engaging the Tractor PTO. Set to operate at your required rpm, usually between 450 and 540 rpm.
- Activate the AGITATORS.
- Activate the mixing BASKET valve (**make sure the lid is closed**).



SECTION 6

SPRAY OPERATIONS

- Allow sufficient time for the chemical to mix into the tank. The actual time will vary depending upon the product used.
- **Close the mixing basket valve** before next opening the lid.

CHEMICAL SUCTION PROBE

An alternative to the mixing basket (which is best used for powders and granules) is the chemical probe. Designed to suck liquid chemical, via a venturi system, straight from containers and into the main tank. Also refer to page 32.

- **Always wear safety gloves**
- Connect the probe to the sprayer as pictured making sure the ball valve (as shown) is in the off position



- Prepare the chemical source. **Be especially vigilant of chemical safety.**
- Check the Tank Selection valve (located at the front of the sprayer) is open to SPRAY.



- Start the Tractor
- Make sure the controller is NOT in Spray mode.
- Start the pump by engaging the Tractor PTO. Set to operate at your required rpm, usually between 450 and 540 rpm. Higher rpm will give better suction.
- Activate the PROBE tap (shown below as closed)



- Place / hold the probe's tube into the chemical source (usually a drum or bucket of chemical).
- To suck chemical from the drum to tank, turn on the probe connection ball valve (**circled in orange**, shown in the off position). Use the ball valve to control the suction.

Modulate the tap opening to adjust liquid transfer speed.

Turn to off when finished or the required volume of chemical has been transferred to the spray tank.

- Flush with / rinse from a clean water source when finished.
- Activate the AGITATORS.
- Once the process is complete, turn off the probe's ball valve and the tap at the pump.

SECTION 6

SPRAY OPERATIONS

CALCULATE WATER & CHEMICAL QUANTITIES

Before spraying it is necessary to calculate the exact quantities of water and chemical needed to spray the required area of orchard or vines.

For **CHEMICAL required** expressed in litres or kg per hectare (land area), use the following formula:

$$\text{Chemicals required (Litres (or Kg))} = \frac{\text{Tank Volume (L)} \times \text{Recommended Chemical Rate (L/ha) or (Kg/ha)}}{\text{Spray Application Rate (L/ha)}}$$

eg.
$$\frac{3000 \times 5 \div 900 \text{ (L/ha)}}{= 21.4 \text{ Litres or (Kg)}}$$

For **tank VOLUME OF MIXTURE required** to spray the selected area, use the following formula:

$$\text{Tank Volume Required (Litres)} = \text{Area (ha)} \times \text{Spray Application Rate (L/ha)}$$

eg.
$$\frac{3.25 \times 900}{= 2925 \text{ Litres}}$$



For **AREA COVERED (ha)**,

$$= \frac{\text{Tank Volume (litres)} + \text{Spray Application Rate (l/ha)}}{}$$

eg.
$$\frac{2925 \div 900}{= 3.25 \text{ hectares}}$$

For **CHEMICAL RATES** expressed in Litres or kg per 100 litres of water (water volume), use the following formula:

$$\text{Chemicals Required (Litres)} = \frac{\text{Tank Volume (Litres)} \times \text{Recommended Chemical Rate (L/100 litres)}}{100}$$

eg.
$$\frac{1500 \times 3 \div 100}{= 45 \text{ Litres}}$$

NOTE

Important: Be sure to mix only enough spray mixture to cover the area required. Avoid wastage and problems of needless chemical disposal.

SECTION 6

SPRAY OPERATIONS

PROCEED TO SPRAY

Once the pre-operation checklist on page 58 has been completed, and chemical mixture is in the tank, proceed to spray:

- **Anyone operating this sprayer must be conversant with the Croplands Safety manual.**
- **Spray operations should be done in conjunction with an agronomist/spray manager/someone skilled in the art of spraying and operating machinery.**

The spray manager will have predetermined the job requirements, such as the following example

- The block to be sprayed, and hence row width and any special instruction on fan setup
- Operating speed (often around 4 ~ 6 Kph)
- Application rate (for example 1,500 L/Hectare). There can be significant variations in application rates due to the crop type (grapes vs tree crop) and product to be applied.
- The nozzles to be used/which spray rings
- Spray pressures to be used (often around 10 ~ 20 bar)
- PTO and Spray pump rpm (often between 450 & 540)

Operating Pointers

- Always drive to the conditions taking into account the load, the terrain and the weather.
- In mixed terrain, spray the flat ground before spraying the hills.

When preparing to spray for the first time.

Stop.

Check that all tank lids are closed, and the Tank Selection Valve is in the SPRAY position. Double check the electric controls or auto rate controller settings (if fitted) – now ready to spray.

While spraying, continually confirm that:

- Recommended and PTO speed are correct
- Correct operating pressure is being maintained
- Ground speed is suitable, safe and constant
- The Fieni Spray fan and nozzles are aimed and operating correctly.

 **WARNING**

SAFETY INSTRUCTIONS

Never operate the sprayer without an emergency action plan /appropriate Personal Protective Equipment or suitable first aid kit.

1. **Read your operators manual thoroughly before operating the sprayer.**
2. **Inspect hoses, connections and nozzles daily.**
3. **Clean filters regularly.**
4. **Always follow correct maintenance schedules outlined in operator's manuals.**
5. **Always read chemical manufacturers labels before use.**
6. **Always observe all warnings on chemical products.**
7. **Regularly check all nuts and bolts are tight.**
8. **Always wear rubber gloves and wash sprayer down before doing any repair or maintenance work.**
9. **Do not ride on sprayer when moving.**
10. **Keep clear of moving parts when sprayer is operating.**
11. **Always keep guards in place when sprayer is operating.**
12. **Be sure tank lid is closed before operating basket mixing facility.**
13. **Stand well clear of sprayer when operating.**
14. **Do not disconnect hoses, nozzles or filters while sprayer is operating.**

**FAILURE TO FOLLOW THE ABOVE INSTRUCTIONS
MAY RESULT IN SERIOUS INJURY OR DEATH.**

Croplands Equipment Pty Ltd XD125MS

DRAIN & FLUSHING

The Cropliner 1500, 2000, 3000 and 4000 Lt sprayers are equipped with a flushing tank for cleaning the sprayer when changing chemicals, and for flushing down at the end of the day.

- Be aware that the flushing tanks may need to be refilled during the process

To flush the Cropliner 1500 ~ 4000:

1. Ensure the site for flushing and cleaning the sprayer meets with environmental and statutory regulations
2. Open tank drain valve to drain the remaining spray mixture from the tank (as pictured below for 1500 ~ 4000 versions – and bottom image for 5000)



SECTION 6

SPRAY OPERATIONS

For the 5000 model, the drain valve handle is accessed at the very bottom / front of the main tank (refer photo – shown in closed position).



4. Open the Tank Selection valve to the FLUSH position, as shown below (2000 ~ 4000 models).



- Note the 5000 Lt model does not include an on board flushing tank. Flushing is via an external clean water source.



- Connect an external clean, freshwater source to the FILL valve. Note the valve below is shown in the OFF position. Connect via camlock (orange circle) and then move the handle towards the water source (orange arrow).
5. Open the mixing basket valve.
 6. Check that agitator valves are open.
 7. Place sprayer controls in start-up position according to the instructions of the controller fitted (see pages 50 - 54).
 8. Engage PTO and bring the PTO speed up to 540 RPM. All pumped liquid is now being passed through the dump valve back into the tank. The system is not pressurised, and tank agitators are not working.
 9. Pressurise the system and operate the tank agitators.
 10. Adjust pressure to desired operating pressure.
 11. Turn the spray booms ON, but firstly
 - a. Make sure the area around the fans is clear of bystanders.
 - b. Make sure the fans are downwind of the operator.

Fresh water now flushes through the suction line, suction filter, pump, agitator(s), pressure (spray) lines, pressure filters (if fitted), nozzles and mixing basket.

The water from the flushing tank not being sprayed comes back to the main tank. Water in the main tank drains out of the tank through the drain outlet.
 12. On completion of flushing, shut down all controls and disengage the PTO.

SECTION 6

SPRAY OPERATIONS

13. Remove and clean and reassemble all filters.
14. Adjust all valves back to operating (spray) mode.
 - a. Close mixing basket valve.
 - b. Close tank drain valve.
 - c. Select Main tank from the tank selection valve.
 - d. Open the agitator valves.

If required, wash/hose down the outside of the sprayer.

NOTE

Sulphur & Copper compounds lead to rapid deterioration of metal and polyethylene surfaces on your sprayer.

It is strongly recommended that you use an exterior cleaner such as FARM MATE after every spray. FARM MATE is available from your Spray Shop

FAN CLEANING

The Fieni fan air intake guards should be regularly checked and if necessary cleaned of leaves and similar debris. ALWAYS disengage the fan when cleaning the guards.



TANK CLEANING

If a cleaning agent is required (refer to the chemical label), as is often recommended when changing from one chemical group to another or as an end of season clean before storage.



Nufarm's Tank and Equipment Cleaner is a suitable cleaning agent. Note this product is available from ratified Croplands Dealers under part code L-H9704.

Below is a guide procedure, but if in doubt, follow the instructions provided with the cleaner.

1. First, completely flush the sprayer with water as outlined in the previous FLUSHING section. Then ...
2. Fill the spray tank with freshwater
3. Add cleaning agent into the mixer basket (use according to instructions)
4. Open the Tank Selection Valve to the SPRAY tank
5. Open mixing basket valve
6. Open the agitator valves
7. Start the Tractor
8. Make sure the controller / electric controls or auto rate controller is NOT in Spray mode. Ensure all sections are selected to enable all spray sections to be flushed.
9. Start the pump by engaging the Tractor PTO. Set to operate at your required rpm, usually between 450 and 540 rpm.
10. Activate the controller SPRAY mode. This will pressurise the system and operate the tank agitators & basket rinse.
11. Adjust to normal operating pressures
12. Turn ON all spray sections.

SECTION 6

SPRAY OPERATIONS

- a. Make sure the area around the fans is clear of bystanders.
 - b. Make sure the fans are downwind of the operator.
13. After sufficient cleaning, turn OFF the spray sections.
 14. If you require the cleaning agent to soak or stand for a period, turn the spray booms OFF and completely shut down the sprayer for the desired period.
 15. When soaking is completed, start the machine following steps to flush the tank and spray lines
 16. On completion of flushing, shut down all controls and disengage the PTO/ hydraulic drive.
 17. Open spray tank drain valve and allow cleaning mixture to drain from the tank
 18. Delay the final flushing of the sprayer (again) with freshwater as outlined in the previous FLUSHING section, until just before the sprayer is next used – that might be in 1 hour or 6 months away if the sprayer is going into storage for the offseason.

UNHITCHING THE SPRAYER FROM THE TRACTOR

Locate sprayer on level ground and block the wheels so that sprayer does not roll when the sprayer is unhitched.

Disconnect PTO shaft and controllers from the tractor.

Attach and adjust all Jockey or park stands before unhitching.

Ensure all caps for the electrical (looms) and hydraulic hose fittings are utilised to help prevent water, dust & dirt ingress.



Wheel Chocks

Wheel chocks should be used whenever the sprayer is not attached to the tractor.



SECTION 7

SPRAYING INFORMATION

SPRAYWISE	71
CALIBRATION	71
FLOWMETER CALIBRATION	72
STEP 1 - ENSURE EQUIPMENT IS IN GOOD WORKING ORDER	72
STEP 2 - DETERMINING THE ACTUAL SPEED OF TRAVEL	74
STEP 3 - DETERMINE SPRAYING VOLUME REQUIRED	74
STEP 4 - DETERMINE SPRAYER CONFIGURATION	74
STEP 5 - DETERMINE THE IDEAL SPRAY PRESSURE	75
STEP 6 - DETERMINE & SELECT CORRECT NOZZLES	75
STEP 7 - FIT & TEST SELECTED NOZZLES	78
STEP 8 - CALCULATE THE ACTUAL APPLICATION RATE	78
STEP 9 - IF THE TESTED RATE IS UNSATISFACTORY	79
STEP 10 - COVERAGE ASSESSMENT	79
STEP 11 - ADD THE CORRECT AMOUNT OF CHEMICAL TO THE TANK	80
STEP 12 - RECORD ALL DATA FOR FUTURE REFERENCE	80
DISCS & CORES	83
CALIBRATION WORK SHEET	85

SECTION 7

SPRAYING INFORMATION

Spraying should be done in conjunction with an agronomist / spray manager / someone skilled in the art of spraying. The best setup might vary significantly from crop to crop, season to season etc.

SPRAYWISE

It's highly recommended that all operators of this sprayer and spray program managers should be fully conversant with the information supplied in the **Nufarm SprayWise Horticultural Application Handbook** (refer photo) before undertaking spray operations.

The book includes chapters discussing re;

- Droplet Size
- Nozzle Types
- Dilute Spraying
- Concentrate Spraying
- Coverage & Assessment
- Selecting Nozzles
- Drift
- Weather
- Adjuvants
- Formulations & Mixing Order
- Cleaning
- Calibration
- Record Keeping
- And more

This book is supplied with every Cropliner, and is available from Croplands dealers, under the part number: SPRAYWISEHK.



CALIBRATION

Applying the correct amount of chemical to a crop is only possible if **the sprayer is calibrated, operated and maintained correctly.**

The variables of spray application (distance, time, working width, liquid, and chemical volumes) must be measured and controlled accurately to ensure chemicals are applied at the correct rate.

Proper calibration involves setting up the sprayer (nozzle selection, pressure, speed), calculating chemical and water rates, and measuring the performance of the sprayer itself. Only then can you be totally confident in applying chemicals correctly.

Fully Automatic Spray Controller (HV4000/ Bravo 180S)

Automatic spray rate controllers maintain the application rate (as set by the operator) when operated in the Auto position.

The controller monitors speed of travel (speed sensor) and flow rate (flow meter) and automatically adjusts flow rate (via a pressure regulating or servo valve) to maintain the correct application rate irrespective of speed variations within the limits of the nozzles used.

IMPORTANT:

- It should be remembered that the spray controller does not eliminate the necessity to measure and check the accuracy of nozzle spray patterns and outputs. These must be checked regularly to ensure correct and uniform application rates because nozzles wear with use.

SECTION 7

SPRAYING INFORMATION

- Flow meters used by the Cropliner Sprayer need to be checked and calibrated on a regular basis.

The following page demonstrates how to maintain and check your Rapid-check flowmeter. It is recommended this is done regularly during the spraying season.



FLOWMETER CALIBRATION

If optioned with auto rate controller, as a part of the initial factory testing / calibration, a value (pulses per litre) will have been recorded and written on the body of the flow meter see example here.



To check / improve the resolution of the flow meter calibration use the below method after having sprayed out a reasonable volume of liquid (the more sprayed the better the resolution);

- The current flow meter calibration number in the controller = X
- Take the total volume the controller says was sprayed and divided by the actual volume sprayed = Your new flow meter calibration.
- Then manually enter this number into the controller settings.

For example;

Current flow cal number (X) = 250. Controller says we have sprayed 4400L after having put 4000L in the tank.

$$250 \times 4400 = 1100000$$

$$1100000 / 4000 = 275 \text{ (new flow cal number)}$$

STEP 1 - ENSURE EQUIPMENT IS IN GOOD WORKING ORDER

Tank, pump, boom, filters and nozzles must be clean, free of leakages and functioning properly.

Follow the pre-operation checklist, maintenance and operating instructions in this manual.

Install, calibrate and operate the spray controller according to the spray controller operators manual.

Inspections of the Flowmeter should be performed regularly.

Daily Check & Maintenance of Flowmeter

This is to be performed every day after work is finished:

1. Unscrew the assembly that holds the Rapid Check unit in the body.
2. Remove the Rapid Check unit from the body.

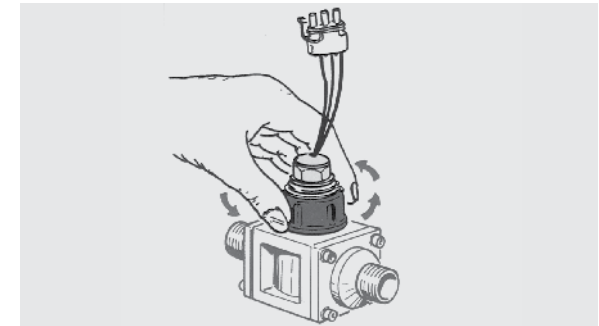

Unscrew the Rapid Check assembly

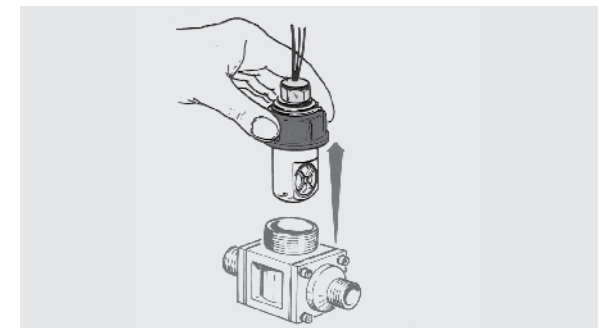

Remove the Rapid Check unit

SECTION 7

SPRAYING INFORMATION

3. Use clean water to wash any impurities out of the removable turbine unit.

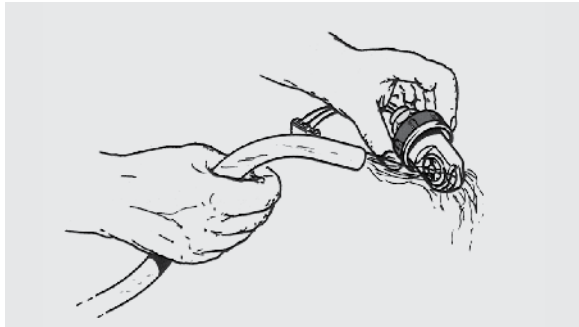

Wash any impurities out of the removable turbine unit

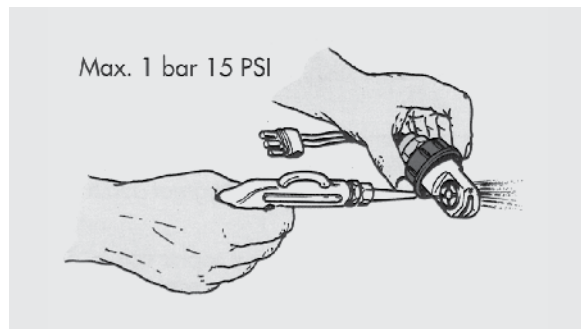

Use compressed air to check that the turbine unit rotates freely

4. Use compressed air to verify that the turbine unit rotates freely (maximum air pressure 1 BAR [15 psi]).

Every 50 Hours

Carry out the following procedure after every 50 hours of operation:

1. Unscrew the sensor.

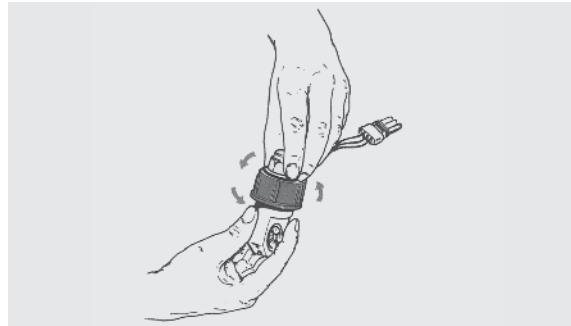

2. Separate the sensor from the Rapid Check unit.



Separate the sensor from the Rapid Check unit

3. Place the Rapid Check unit in a detergent bath for a few hours.

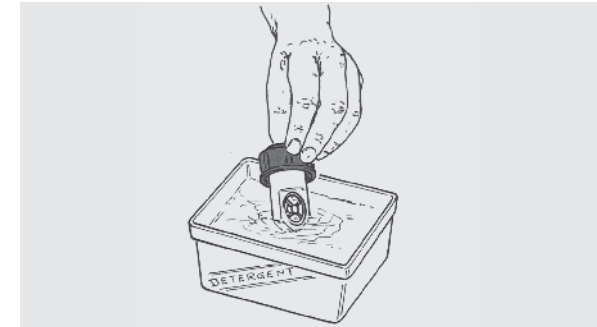

Place the Rapid Check unit in a detergent bath

4. Remove the Rapid Check unit from detergent bath. Use compressed air to verify that the turbine unit rotates freely (maximum air pressure 1 BAR [15 psi]). If necessary, replace the Rapid Check unit with a new one.

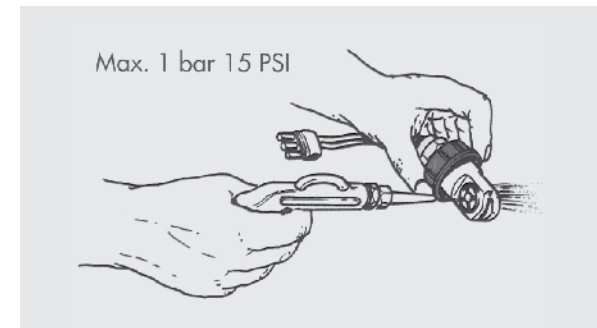

Use compressed air to check that the turbine unit rotates freely

SECTION 7

SPRAYING INFORMATION

STEP 2 - DETERMINING THE ACTUAL SPEED OF TRAVEL

If optioned with auto rate controller, your sprayer has been factory set with a calibration number. This should be fine tuned prior to commencement of spraying and checked by your dealer. This is done by traveling a known distance (usually 100 metres) and comparing the distance measured by the Spray Controller to the known distance. If there is a discrepancy, the Spray Controller Manual explains how to easily adjust the calibration number automatically.

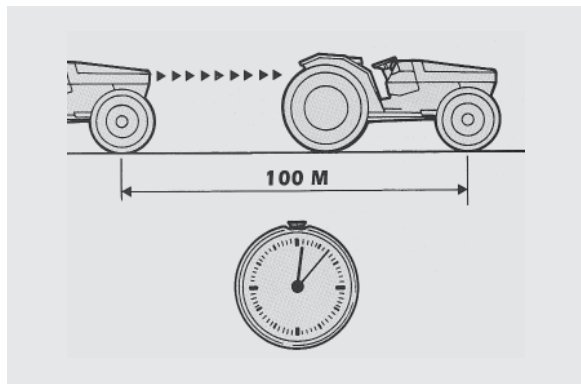

To manual check the speed...

- Half fill the sprayer tank with water and mark out a test strip of 100 metres (simulating spraying conditions).
- Set the sprayer operating and record the time taken to travel 100 metres at your required spraying speed.

c) Calculate the actual speed of travel using the formula:

For SPEED, km/hr = using the following formula:

$$\frac{\text{Distance (m)} \times 3.6}{\text{Time (sec)}}$$

eg. $100(\text{m}) \times 3.6 \div 72(\text{seconds})$

$$= 5\text{km/hr travel speed}$$

An alternative formula is:

$$\text{km/hr} = \text{Metres travelled in 1 minute}$$

STEP 3 - DETERMINE SPRAYING VOLUME REQUIRED

It is essential to determine the liquid volume per hectare required to effectively spray a crop without overspraying or underspraying.

The spray volume requirement should be determined by / in conjunction with an agronomist / spray manager / someone skilled in the art of spraying.

The term "litres per hectare" must be related to foliage and not just to land area. The amount of liquid needed to effectively spray any given crop will vary greatly with:

- The type of crop
- Row spacing
- Width of canopy
- Height of canopy
- Stage of growth
- Density of foliage

- Type of leaf surface
- Type of fruit (single or bunched)
- Type of sprayer used

For example, using a Cropliner, spray volumes for Grapes will typically vary from 600 to 1200 L/Ha.

Tree crops (e.g. Almonds, Avocado, Citrus etc) tend to be 1000 ~ 2000 L/Ha but can be 6,000 L/Ha or more in some applications.

STEP 4 - DETERMINE SPRAYER CONFIGURATION

Once the volume of required spray volume per hectare is established, the next step in setting up the sprayer is to determine:

- The **number of row(s)** to be sprayed in one pass (always 1 row for a Cropliner), and
- The **total number of nozzles** to be used.

Both these factors can vary with the model of sprayer used and other factors mentioned under step 3.

Example A

A Cropliner equipped with Fieni 920mm fan, to spray grapes, using 10 of the 14 nozzles per side (top 4 nozzles turned off), for a total of 20 nozzles spraying a spray one row per pass.

Example B

A Cropliner equipped with Fieni 1060mm fan, to spray avocados with 15 nozzles each side (total nozzles 30) spraying all one row per pass.

SECTION 7

SPRAYING INFORMATION

STEP 5 - DETERMINE THE IDEAL SPRAY PRESSURE

Before determining the correct nozzles, it's best to have an idea of the spray pressure required. As a general rule, a pressure of 10 - 20 bar is considered ideal for Cropliner spraying. Note nozzles also have differing optimal pressure ranges. Refer to the Spraywise book for more information.

Setting up the sprayer around a pressure of say 14 - 16 bar will allow lower pressures (say 10 - 13 bar) to be used in early season and higher pressure (say 17 - 20 bar) for later season without having to change nozzles mid season. It will also offer some margin around travelling slower or faster than the chosen speed.

The advice provided above is general information only and operators should seek specialised advice from their agronomist/spray manager/someone skilled in the art of spraying.

STEP 6 - DETERMINE & SELECT CORRECT NOZZLES

Knowing actual travel speed, application rate required, number of rows to be sprayed in one pass, total number of nozzles to be used and ideal spray pressure, we can determine the nozzles required for the sprayer.

The calculation formulation is;

$$\frac{\text{Litres/Minute/Nozzle}}{\text{(Litres per minute per nozzle)}} = \frac{\text{Litres/Ha} \times \text{Km/hr} \div 600}{\text{total number of nozzles used} \times \text{row spacing (m)} \times \text{number of rows in one pass}}$$

Once the flow rate per nozzle is known select the most appropriate nozzle from a flowrate chart for the nozzle being used. Flowrate charts are available from relevant nozzle suppliers. Croplands supplies and recommends the ALBUZ ATR Hollow Cone or Disc & Core ceramic nozzles.

Pictured left and overleaf is a screenshot taken from a small spreadsheet program freely available from the Croplands Web Site or Croplands Customer Service titled "ALBUZ Nozzle Selection Worksheet" which makes it much quicker to calculate nozzle requirements. For more nozzles see the Croplands Compact buyers guide.

Refer to page 82 for the Disk & Core flow rate information.

ALBUZ Nozzle Selection Worksheet

Step 6A

Enter data in grey boxes.

Example 1			
Target rate (L/ha)	<input type="text" value="900"/>	Speed (km/hr)	<input type="text" value="5"/>
Row spacing (m)	<input type="text" value="3"/>	Number of rows	<input type="text" value="1"/>
Number of nozzles	<input type="text" value="28"/>		
Total L/min =	22.5	L/min per nozzle	0.80

Step 6B

Select nozzles from chart, (see page 82 for disk and core information).

ALBUZ NOZZLE	PART NUMBER	MESH	5 Bar	6 Bar	7 Bar	8 Bar	9 Bar	10 Bar	11 Bar	12 Bar	13 Bar	14 Bar	15 Bar	16 Bar	17 Bar	18 Bar	19 Bar	20 Bar
WHITE	AZ-ATR-WE-80C	100	0.27	0.29	0.32	0.34	0.36	0.38	0.39	0.41	0.43	0.44	0.46	0.47	0.48	0.50	0.51	0.52
LILAC	AZ-ATR-IC-80C	50	0.36	0.39	0.42	0.45	0.48	0.50	0.52	0.55	0.57	0.59	0.61	0.63	0.64	0.66	0.68	0.70
BROWN	AZ-ATR-BN-80C	50	0.48	0.52	0.56	0.60	0.64	0.67	0.7	0.73	0.76	0.79	0.81	0.84	0.86	0.89	0.91	0.93
YELLOW	AZ-ATR-YW-80C	50	0.73	0.80	0.86	0.92	0.97	1.03	1.07	1.12	1.17	1.21	1.25	1.29	1.33	1.37	1.4	1.44
ORANGE	AZ-ATR-OE-80C	50	0.99	1.08	1.17	1.24	1.32	1.39	1.45	1.51	1.57	1.63	1.69	1.74	1.84	1.84	1.89	1.94
RED	AZ-ATR-RD-80C	50	1.38	1.51	1.62	1.73	1.83	1.92	2.01	2.09	2.17	2.25	2.33	2.40	2.54	2.54	2.6	2.67
GREY	AZ-ATR-GY-80C	50	1.5	1.63	1.76	1.87	1.98	2.08	2.17	2.26	2.35	2.43	2.51	2.59	2.74	2.74	2.81	2.88
GREEN	AZ-ATR-GN-80C	50	1.78	1.94	2.09	2.22	2.35	2.47	2.58	2.69	2.79	2.89	2.99	3.08	3.25	3.25	3.34	3.42
BLACK	AZ-ATR-BK-80C	50	2	2.18	2.35	2.50	2.64	2.78	2.9	3.03	3.14	3.26	3.36	3.47	3.67	3.67	3.76	3.85
BLUE	AZ-ATR-BE-80C	50	2.45	2.67	2.87	3.06	3.24	3.40	3.56	3.71	3.85	3.99	4.12	4.25	4.49	4.49	4.61	4.72

SECTION 7

SPRAYING INFORMATION

In the example on previous page, using the following Spray parameters ...

Target rate = 900 (L/Ha)

Row Spacing = 3 (M)

Number of Nozzles = 28

Speed = 5 (km/hr)

Number of Rows = 1

These parameters calculate to a requirement of 22.5 L/min, which divided across the 28 nozzles calls for 0.80 L/Min per nozzle.

Cross referencing this rate to the Albus nozzle chart shows the Brown nozzle at 15 Bar (0.81 L/min) to be a suitable choice.

Across the spraying season the variables (such as chemical type, rates and speeds) may often change. With a well setup system small variations will be easily accommodated. Larger variations may require a change of nozzles.

Example 2

Below is an example of a higher spray rate requirement in wide rows at slow speed across more nozzles. The suggested nozzle (starting point) would be the Grey Albus nozzles at 15 Bar.

Example 2			
Target rate (L/ha)	<input type="text" value="1800"/>	Speed (km/hr)	<input type="text" value="5"/>
Row spacing (m)	<input type="text" value="5"/>	Number of rows	<input type="text" value="1"/>
Number of nozzles	<input type="text" value="30"/>		
Total L/min =	75	L/min per nozzle	2.5

Step 6C Basic Nozzle Configuration

The Fieni 920 & 1060 DSV fans feature dual rows of nozzles. Use the calibration worksheet to determine the basic nozzle configuration.

The below nozzle layout example shows the Yellow ATR nozzles as standard fitment to Fieni 920 DSV fans. (Refer next page for disk & core layout).

This formula matches 960 L/Ha at 3m row spacing, 28 nozzles, 6 k/hr speed in 1 row = 28.8 L/min



NOTE

Earlier Cropliner sprayers (and the current Linkage Cropair 300/600 range) use Fieni fans with a single row of nozzle bodies.

Fieni 920 DSV Fan, as factory fitted "standard", Albus ATR Hollow Cone Nozzles.

Note customer can nominate an alternative nozzle configuration at time of order.

◀ Front Spray Ring				Rear Spray Ring			
Nozzle	ALBUZ Hollow Cone	Discharge	Spray angle	Nozzle	ALBUZ Hollow Cone	Discharge	Spray angle
Top 1	AZ-ATR-YW-80C	1.03	80 deg	Top 8	AZ-ATR-YW-80C	1.03	80 deg
2	AZ-ATR-YW-80C	1.03	80 deg	9	AZ-ATR-YW-80C	1.03	80 deg
3	AZ-ATR-YW-80C	1.03	80 deg	10	AZ-ATR-YW-80C	1.03	80 deg
Middle 4	AZ-ATR-YW-80C	1.03	80 deg	Middle 11	AZ-ATR-YW-80C	1.03	80 deg
5	AZ-ATR-YW-80C	1.03	80 deg	12	AZ-ATR-YW-80C	1.03	80 deg
6	AZ-ATR-YW-80C	1.03	80 deg	13	AZ-ATR-YW-80C	1.03	80 deg
Bottom 7	AZ-ATR-YW-80C	1.03	80 deg	Bottom 14	AZ-ATR-YW-80C	1.03	80 deg
		one side =	7.21			one side =	7.21
10 Bar	Pressure	14.42	L/min FRONT Spray Ring	28.84	L/Min ALL NOZZLES	14.42	L/min REAR Spray Ring

SECTION 7

SPRAYING INFORMATION

Step 6D Final Nozzle Configuration

Depending on size and shape of the spray target it may be necessary to turn some nozzles off due to a lack of foliage, or to specifically target certain zones of the canopy with higher spray rates.

For example, within grapes it's quite common for one or more top rows of nozzles to be turned off due to no foliage and to target the bunch line with a higher spray rate - whilst maintaining the chosen spray rates and pressures. Refer to example shown.



Fieni 920 DSV Fan, DETAILED NOZZLE PLAN, Albuz ATR Hollow Cone Nozzles.

◀ Front Spray Ring				Rear Spray Ring			
Nozzle	ALBUZ Hollow Cone	Discharge	Spray angle	Nozzle	ALBUZ Hollow Cone	Discharge	Spray angle
Top 1	AZ-ATR-BN-80C	OFF	n/a	Top 8	AZ-ATR-BN-80C	OFF	n/a
2	AZ-ATR-BN-80C	0.67	80 deg	9	AZ-ATR-BN-80C	0.67	80 deg
3	AZ-ATR-YW-80C	1.03	80 deg	10	AZ-ATR-YW-80C	1.03	80 deg
Middle 4	AZ-ATR-OE-80C	1.39	80 deg	Middle 11	AZ-ATR-OE-80C	1.39	80 deg
5	AZ-ATR-RD-80C	1.92	80 deg	12	AZ-ATR-RD-80C	1.92	80 deg
6	AZ-ATR-YW-80C	1.03	80 deg	13	AZ-ATR-YW-80C	1.03	80 deg
Bottom 7	AZ-ATR-YW-80C	1.03	80 deg	Bottom 14	AZ-ATR-YW-80C	1.03	80 deg
		one side =	7.07			one side =	7.07
10 Bar	Pressure	14.14	L/min FRONT Spray Ring	28.28	L/Min ALL NOZZLES	14.14	L/min REAR Spray Ring

Fieni 1060 DSV Fan, as factory fitted "standard", Disk & Core Nozzles.
Note customer can nominate an alternative nozzle configuration at time of order.

◀ Front Spray Ring					Rear Spray Ring				
Nozzle	Disc No.	Core No.	Discharge	Spray angle	Nozzle	Disc No.	Core No.	Discharge	Spray angle
Top 1	AD4	AC56	3.52	35 deg	Top 9	AD4	AC56	3.52	35 deg
2	AD4	AC56	3.52	35 deg	10	AD4	AC56	3.52	35 deg
3	AD4	AC56	3.52	35 deg	11	AD4	AC56	3.52	35 deg
Middle 4	AD4	AC56	3.52	35 deg	Middle 12	AD4	AC56	3.52	35 deg
5	AD3	AC56	2.05	28 deg	13	AD3	AC56	2.05	28 deg
6	AD3	AC56	2.05	28 deg	14	AD3	AC56	2.05	28 deg
7	AD3	AC35	2.2	44 deg	Bottom 15	AD3	AC35	2.2	44 deg
Bottom 8	AD3	AC35	2.2	44 deg	Note the rear spray ring has 1 less nozzle				
			one side =	22.58				one side =	20.38
10 Bar	Pressure	45.16	L/min FRONT Spray Ring	85.92	L/Min ALL NOZZLES	40.76	L/min REAR Spray Ring		

It's suggested that a photocopy of the blank worksheet (see pages 82 ~ 87) be used for each calibration and kept for future reference. Below left is a sample calibration sheet using disk & core nozzles fitted to a Fieni 1060 fan for a high volume application.

NOTE
Remember when selecting nozzle outputs that higher pressures and wider spray angles usually give finer droplet sizes than lower pressures and narrower spray angles.

NOTE
The flow rate of each nozzle is dependent on the nozzle size and operating pressure.

DISCLAIMER:
Because of the many variable factors involved Croplands can not be held responsible for any down grading or loss of crop resulting from the use of any information in this manual.

SECTION 7

SPRAYING INFORMATION

STEP 7 - FIT & TEST SELECTED NOZZLES

The most important calibration is to test for the actual litres per hectare achieved through your sprayer.

- Use the following method to fit and test the selected nozzles:
- Fit selected nozzles to the sprayer.
- Fill your spray tank to maximum capacity & set the specified pump pressure and operate the sprayer for a short period to make sure all lines are full and nozzles are working properly (no blockages, leaks etc).
- Stop the sprayer and top up the tank with water to maximum capacity again.
- Operate the sprayer in the stationary position at the required pressure for not less than one minute.
- Measure how much water is required to refill the tank to the brim.
- Now, divide the volume measured by the time taken (minutes). The longer the test time the more accurate the figure.

The calculation formulation is;

Output (L/min) =

$$\frac{\text{Output (litres)}}{\text{Time (minutes)}}$$

Example 1			
Target rate (L/ha)	<input type="text" value="900"/>	Speed (km/hr)	<input type="text" value="5"/>
Row spacing (m)	<input type="text" value="3"/>	Number of rows	<input type="text" value="1"/>
Number of nozzles	<input type="text" value="28"/>		
Total L/min =	22.5	L/min per nozzle	0.80

Test as per example 1 (page 75) as above.

$$\frac{28.5 \text{ litres}}{1.25 \text{ minutes (75 seconds)}} = 22.8 \text{ litres/min}$$

Which is slightly more than the target of 22.5L/min (0.8 L/min per nozzle x 28 nozzles for 1.0 min)

- Excessive output is a sign of worn nozzles. See steps 8 & 9.
- Insufficient output is a sign of blockages. See steps 8 & 9.

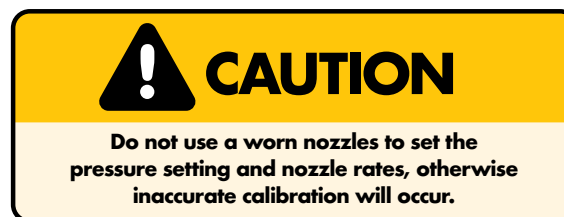

STEP 8 - CALCULATE THE ACTUAL APPLICATION RATE

Actual application rate is the objective of setting up and calibrating your sprayer.

To calculate actual application rate (litres per hectare), use the following formula:

$$\text{Application Rate (L/ha)} = \frac{\text{Total sprayer output (L/min)} \times 600}{\text{speed (Km/hr)} \div \text{row spacing (m)} \div \text{number rows in one pass}}$$

Example 1 (as per Tier 1 example)

$$\frac{22.8 \text{ (L/min)} \times 600}{\div 5 \text{ (kph)} \div 3\text{m (row)} \div 1 \text{ (row)}} = 912 \text{ litres/ha}$$

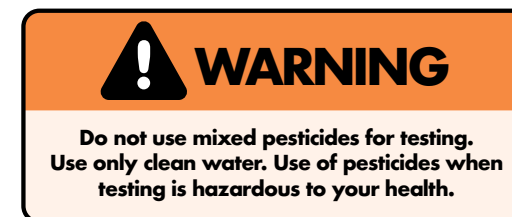

LITRES PER 100 METRES / ROW

Many Auto Rate controllers have an option for Litres per 100 metres and is occasionally the unit of preference in some vineyard operations. It's a simpler formula as row width is not relevant.

The calculation requires volume and distance, such as 11 litres per 100 metres (of rows). The operator only needs to follow the chemical label rate for mixing concentrate per 100 L.

Flowrate conversion charts are available in the Nufarm SprayWise Horticultural application handbook and the Croplands Compact Sprayers buyers guide.

Example 1

Using the chart on page 81, 900 Lt / ha x 3m rows correlates to 27 litres per 100 metres of row.

STEP 9 - IF THE TESTED RATE IS UNSATISFACTORY

If your tested application rate does not meet your requirements, your options are:

A) In Auto mode - if the application rate is not being achieved:

- Operating pressure will be excessive if nozzles are too small or blocked or speed is too fast.

Likewise, if your pressure filter is blocked (even partially), you may experience excessive pressure at the pump.

Make adjustments accordingly.

- Operating pressure will fall if nozzles are too large or speed is too slow. Make adjustments accordingly.

B) In Manual mode - the Controller application rate can be altered by:

- Adjusting pressure up or down to increase or decrease rate of application (use +/- keys).
- Adjusting spraying speed up or down to decrease or increase rate of application.
- Changing to a different nozzle capacity.

Repeat necessary testing procedures and calculation of application rate if adjustments or changes are made

STEP 10 - COVERAGE ASSESSMENT

Operate your sprayer in the required orchard or vineyard to check the actual spray coverage achieved on foliage.

This is important because it is the only real measure you have of actual coverage and effective penetration of your sprayer.

Coverage checks can be done using:

- Water Sensitive Papers (as pictured) and available through Croplands dealers – see Croplands Buyers guide for further details.
- Clay Markers as available through Croplands dealers – see Croplands Buyers guide for further details.
- Fluorescent Dye system as available through Croplands dealers – see Croplands Buyers guide for further details.

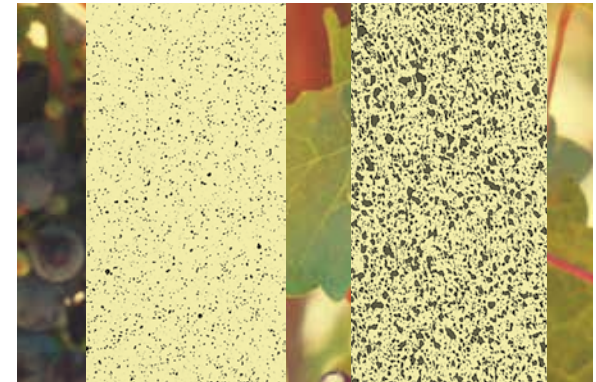

It is recommended to test the unit using water only as a test run, and again when applying your chemical mixture.

Ensure water sensitive papers are strategically placed on both upper and lower surfaces.

Spray testing, evaluation and adjustment to the sprayer (say fan positions) or spray settings (say nozzles, pressures and rates) should be done in conjunction with an agronomist / spray manager / someone skilled in the art of spraying. The best setup might vary significantly from crop to crop, season to season etc.

SECTION 7

SPRAYING INFORMATION

STEP 11 - ADD THE CORRECT AMOUNT OF CHEMICAL TO THE TANK

For land area rates (Litres or kg per hectare)

Use the following formula:

$$\text{Chemical required (Litres) =} \\ \frac{\text{Tank volume (Litres) x} \\ \text{recommended chemical rate (L/ha)}}{\text{÷ spray application rate (L/ha)}}$$

For example;

$$2000 \text{ (litre tank) x } 2.0 \text{ (chemical rate L/ha)} \\ \div 50 \text{ (spray application rate L/ha)} \\ = 80 \text{ litres of chemical}$$

If chemical recommendation is given in water volume rates

Use the following formula:

$$\text{Chemical required (Litres) =} \\ \frac{\text{Tank volume (Litres) x} \\ \text{recommended chemical rate (L/100 litres)}}{\div 100}$$

For example;

$$2000 \text{ (litre tank) x } 4 \text{ (chemical rate L/100 litres)} \\ \div 100 = 80 \text{ litres of chemical}$$

For tank volume required,

Use the following formula:

$$\text{Tank volume required (Litres) =} \\ \text{Area (ha) x spray application rate (L/ha)}$$

For example;

$$20 \text{ (hectares) x } 50 \text{ (application rate, L/ha)} \\ = 1000 \text{ litres of spray tank capacity required}$$

STEP 12 - RECORD ALL DATA FOR FUTURE REFERENCE

Record all your calibration data on the work sheets given at the end of this section.

Photocopy the work sheets to obtain the number of work sheets required.

SECTION 7

SPRAYING INFORMATION

L/ha ↔ L/100 m																											
Row Spacing (metres)																											
	1.6	1.8	2	2.1	2.4	2.5	2.7	2.8	2.9	3	3.1	3.2	3.3	3.5	3.6	4	4.5	5	5.5	6	6.5	7	7.5	8	8.5	9	10
100	1.6	1.8	2	2.1	2.4	2.5	2.7	2.8	2.9	3	3.1	3.2	3.3	3.5	3.6	4	4.5	5	5.5	6	6.5	7	7.5	8	8.5	9	10
150	2.4	2.7	3	3.1	3.6	3.8	4	4.2	4.4	4.5	4.7	4.8	5	5.3	5.4	6	6.8	7.5	8.3	9	9.8	10.5	11.3	12	12.8	13.5	15
200	3.2	3.6	4	4.2	4.8	5	5.4	5.6	5.8	6	6.2	6.4	6.7	7	7.2	8	9	10	11	12	13	14	15	16	17	18	20
250	4	4.5	5	5.2	6	6.3	6.7	7	7.3	7.5	7.8	8	8.3	8.8	9.0	10	11.3	12.5	13.8	15	16.3	17.5	18.8	20	21	23	25
300	4.8	5.4	6	6.3	7.1	7.5	8.1	8.4	8.7	9	9.3	9.6	10	10.5	10.8	12	13.5	15	16.5	18	19.5	21	23	24	26	27	30
350	5.6	6.3	7	7.3	8.3	8.8	9.4	9.8	10.2	10.5	10.9	11.2	11.7	12.3	12.6	14	15.8	17.5	19.3	21	23	25	26	28	30	32	35
400	6.4	7.2	8	8.3	9.5	10	10.8	11.2	11.6	12	12.4	12.8	13.3	14	14.4	16	18	20	22	24	26	28	30	32	34	36	40
450	7.2	8.1	9	9.4	11	11.3	12.1	12.6	13.1	13.5	14	14.4	15	15.8	16.2	18	20	23	25	27	29	32	34	36	38	41	45
500	8	9	10	10	12	12.5	13.5	14	14.5	15	15.5	16	16.7	17.5	18	20	23	25	28	30	33	35	38	40	43	45	50
600	9.6	10.8	12	13	14	15	16.2	16.8	17.4	18	18.6	19.2	20	21	22	24	27	30	33	36	39	42	45	48	51	54	60
700	11.2	12.6	14	15	17	17.5	18.9	19.6	20	21	22	22	23	25	25	28	32	35	39	42	46	49	53	56	60	63	70
750	12	13.5	15	16	18	18.8	20	21	22	23	23	24	25	26	27	30	34	38	41	45	49	53	56	60	64	68	75
800	12.8	14.4	16	17	19	20	22	22	23	24	25	26	27	28	29	32	36	40	44	48	52	56	60	64	68	72	80
900	14.4	16.2	18	19	21	23	24	25	26	27	28	29	30	32	32	36	41	45	50	54	59	63	68	72	77	81	90
1000	16	18	20	21	24	25	27	28	29	30	31	32	33	35	36	40	45	50	55	60	65	70	75	80	85	90	100
1100	17.6	19.8	22	23	26	28	30	31	32	33	34	35	37	39	40	44	50	55	61	66	72	77	83	88	94	99	110
1200	19.2	22	24	25	29	30	32	34	35	36	37	38	40	42	43	48	54	60	66	72	78	84	90	96	102	108	120
1300	21	23	26	27	31	33	35	36	38	39	40	42	43	46	47	52	59	65	72	78	85	91	98	104	111	117	130
1400	22	25	28	29	33	35	38	39	41	42	43	45	47	49	50	56	63	70	77	84	91	98	105	112	119	126	140
1500	24	27	30	31	36	38	40	42	44	45	47	48	50	53	54	60	68	75	83	90	98	105	113	120	128	135	150
1600	26	29	32	33	38	40	43	45	46	48	50	51	53	56	58	64	72	80	88	96	104	112	120	128	136	144	160
1700	27	31	34	35	40	43	46	48	49	51	53	54	57	60	61	68	77	85	94	102	111	119	128	136	145	153	170
1800	29	32	36	38	43	45	49	50	52	54	56	58	60	63	65	72	81	90	99	108	117	126	135	144	153	162	180
1900	30	34	38	40	45	48	51	53	55	57	59	61	63	67	68	76	86	95	105	114	124	133	143	152	162	171	190
2000	32	36	40	42	48	50	54	56	58	60	62	64	67	70	72	80	90	100	110	120	130	140	150	160	170	180	200
2500	40	45	50	52	60	63	67	70	73	75	78	80	83	88	90	100	113	125	138	150	163	175	188	200	213	225	250
3000	48	54	60	63	71	75	81	84	87	90	93	96	100	105	108	120	135	150	165	180	195	210	225	240	255	270	300
4000	64	72	80	83	95	100	108	112	116	120	124	128	133	140	144	160	180	200	220	240	260	280	300	320	340	360	400
5000	80	90	100	104	119	125	135	140	145	150	155	160	167	175	180	200	225	250	275	300	325	350	375	400	425	450	500
6000	96	108	120	125	143	150	162	168	174	180	186	192	200	210	216	240	270	300	330	360	390	420	450	480	510	540	600
7000	112	126	140	146	167	175	189	196	203	210	217	224	233	245	252	280	315	350	385	420	455	490	525	560	595	630	700
8000	128	144	160	167	190	200	216	224	232	240	248	256	266	280	288	320	360	400	440	480	520	560	600	640	680	720	800
9000	144	162	180	188	214	225	243	252	261	270	279	288	300	315	324	360	405	450	495	540	585	630	675	720	765	810	900
10000	160	180	200	208	238	250	270	280	290	300	310	320	333	350	360	400	450	500	550	600	650	700	750	800	850	900	1000

LITRES PER 100 METRES / ROW

Many Auto Rate controllers have an option for Litres per 100 metres and is occasionally the unit of preference in some vineyard operations. It's a simpler formula as row width is not relevant.

The calculation requires volume and distance, such as 11 litres per 100 metres (of rows). The operator only needs to follow the chemical label rate for mixing concentrate per 100 L.

Flowrate conversion charts are available in the Nufarm SprayWise Horticultural application handbook and the Croplands Compact Sprayers buyers guide.

Example 1

Using the chart left, 900 Lt / ha x 3m rows correlates to 27 litres per 100 metres of row.

SECTION 7

SPRAYING INFORMATION

Standard (refer page 57) supplied hollow cone nozzle is Albus Yellow.

ALBUZ-ATR 80° HOLLOW CANE NOZZLES



AZ-ATR-**-80C
**DENOTES COLOUR, E.G. YW

** Colour codes:

WE = white **LC** = lilac
BN = brown **YW** = yellow
OE = orange **RD** = red
GY = grey **GN** = green
BK = black **BE** = blue
PE = purple

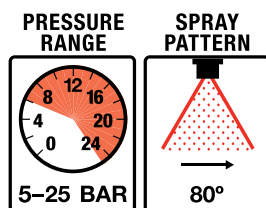

Features:

- Hollow cone angle of 80° at 5 bar
- Polished ceramics ensure perfect sealing and precise flow rate
- Easily dismantled for cleaning
- Perfect sealing of swirl chamber for precise flow rate
- Pressure range 0–25 bar (optimum 8–15 bar)
- Ideal for fungicides and insecticides
- Fine to very-fine droplets for excellent spray coverage
- European colour coded (see chart below for pressure, flow rates and colours)

Applications:

- For fungicides and insecticides
- Recommended for orchards and vineyards.



ALBUZ ATR 80° HOLLOW CONE NOZZLE CHART

ALBUZ NOZZLE	PART NUMBER	MESH	5 Bar	6 Bar	7 Bar	8 Bar	9 Bar	10 Bar	11 Bar	12 Bar	13 Bar	14 Bar	15 Bar	16 Bar	17 Bar	18 Bar	19 Bar	20 Bar	
WHITE	AZ-ATR-WE-80C	100	0.27	0.29	0.32	0.34	0.36	0.38	0.39	0.41	0.43	0.44	0.46	0.47	0.48	0.50	0.51	0.52	
LILAC	AZ-ATR-LC-80C	50	0.36	0.39	0.42	0.45	0.48	0.50	0.52	0.55	0.57	0.59	0.61	0.63	0.64	0.66	0.68	0.70	
BROWN	AZ-ATR-BN-80C	50	0.48	0.52	0.56	0.60	0.64	0.67	0.7	0.73	0.76	0.79	0.81	0.84	0.86	0.89	0.91	0.93	
CURRENT STANDARD	YELLOW	AZ-ATR-YW-80C	50	0.73	0.80	0.86	0.92	0.97	1.03	1.07	1.12	1.17	1.21	1.25	1.29	1.33	1.37	1.4	1.44
	ORANGE	AZ-ATR-OE-80C	50	0.99	1.08	1.17	1.24	1.32	1.39	1.45	1.51	1.57	1.63	1.69	1.74	1.84	1.84	1.89	1.94
	RED	AZ-ATR-RD-80C	50	1.38	1.51	1.62	1.73	1.83	1.92	2.01	2.09	2.17	2.25	2.33	2.40	2.54	2.54	2.6	2.67
	GREY	AZ-ATR-GY-80C	50	1.5	1.63	1.76	1.87	1.98	2.08	2.17	2.26	2.35	2.43	2.51	2.59	2.74	2.74	2.81	2.88
	GREEN	AZ-ATR-GN-80C	50	1.78	1.94	2.09	2.22	2.35	2.47	2.58	2.69	2.79	2.89	2.99	3.08	3.25	3.25	3.34	3.42
	BLACK	AZ-ATR-BK-80C	50	2	2.18	2.35	2.50	2.64	2.78	2.9	3.03	3.14	3.26	3.36	3.47	3.67	3.67	3.76	3.85
	BLUE	AZ-ATR-BE-80C	50	2.45	2.67	2.87	3.06	3.24	3.40	3.56	3.71	3.85	3.99	4.12	4.25	4.49	4.49	4.61	4.72

NOZZLE SELECTION DISCS & CORES

NOZZLES - DISCS AND CORES

TYPE AND DESCRIPTION	Disc and Core Jets:	
	<ul style="list-style-type: none"> • Full and hollow cone spray patterns • Medium to fine droplets for use in air assisted situations • 5–20 bar recommended range 	
SAMPLE ORDER CODE	AZ-AD*	AZ-AC*
TYPE	Disc	Core
SIZE RANGE, MATERIAL	1 to 7 Pink ceramic	13 to 56 Pink ceramic

Standard (refer to page 77) supplied disk & core is Albus AD4 / AC35 and /or AD4 / AC56.

DISC AND CORE ALBUS CERAMIC - FLOW RATES

DISC SIZE	CORE SIZE	ORIFICES				L/MIN					ANGLES	
		DIAMETER	3 BAR	4 BAR	5 BAR	6 BAR	10 BAR	15 BAR	20 BAR	10 BAR	20 BAR	
AD 1	AC 3	0,8	0,24	0,27	0,3	0,33	0,41	0,49	0,56	70	79	
AD 2	AC 13	1,02	0,31	0,35	0,39	0,42	0,53	0,64	0,73	87	97	
AD 3	AC 13	1,2	0,36	0,41	0,45	0,49	0,61	0,74	0,84	89	98	
AD 4	AC 13	1,56	0,45	0,52	0,57	0,62	0,78	0,93	1,06	99	103	
AD 5	AC 13	2	0,55	0,62	0,69	0,75	0,94	1,13	1,29	102	105	
AD 1	AC 23	0,8	0,28	0,32	0,35	0,38	0,48	0,57	0,65	66	74	
AD 2	AC 23	1,02	0,37	0,43	0,47	0,51	0,64	0,77	0,88	83	93	
AD 3	AC 23	1,2	0,44	0,51	0,56	0,61	0,76	0,92	1,04	84	92	
AD 4	AC 23	1,56	0,56	0,64	0,71	0,77	0,97	1,16	1,32	92	98	
AD 5	AC 23	2	0,72	0,82	0,91	0,99	1,24	1,49	1,7	96	99	
AD 6	AC 23	2,4	0,85	0,97	1,07	1,16	1,46	1,75	2	99	101	
AD 1	AC 25	0,8	0,41	0,46	0,51	0,55	0,7	0,84	0,95	50	60	
AD 2	AC 25	1,02	0,59	0,67	0,74	0,8	1,01	1,21	1,38	57	66	
AD 3	AC 25	1,2	0,72	0,81	0,9	0,98	1,23	1,48	1,68	63	69	
AD 4	AC 25	1,56	1,02	1,16	1,28	1,39	1,75	2,1	2,39	75	80	
AD 5	AC 25	2	1,41	1,6	1,77	1,92	2,42	2,9	3,3	77	80	
AD 6	AC 25	2,4	1,73	1,97	2,18	2,37	2,98	3,57	4,07	82	85	
AD 7	AC 25	2,8	2,07	2,36	2,61	2,83	3,57	4,28	4,87	88	91	
AD 1	AC 45	0,8	0,48	0,55	0,61	0,66	0,83	1	1,14	32	39	
AD 2	AC 45	1,02	0,73	0,83	0,92	1	1,26	1,51	1,72	46	53	
AD 3	AC 45	1,2	0,92	1,05	1,16	1,26	1,58	1,9	2,16	48	52	
AD 4	AC 45	1,56	1,35	1,54	1,7	1,85	2,32	2,79	3,17	59	60	
AD 5	AC 45	2	1,92	2,19	2,42	2,63	3,31	3,97	4,52	68	70	
AD 6	AC 45	2,4	2,46	2,79	3,09	3,35	4,22	5,07	5,77	72	75	
AD 7	AC 45	2,8	3,01	3,43	3,79	4,11	5,18	6,21	7,07	79	80	
AD 1	AC 46	0,8	0,55	0,62	0,69	0,75	0,94	1,13	1,29	23	27	
AD 2	AC 46	1,02	0,92	1,05	1,16	1,26	1,58	1,9	2,16	26	30	
AD 3	AC 46	1,2	1,2	1,37	1,51	1,64	2,06	2,48	2,82	30	30	
AD 4	AC 46	1,56	2,03	2,32	2,56	2,78	3,5	4,2	4,78	35	35	
AD 5	AC 46	2	3,11	3,54	3,91	4,24	5,34	6,41	7,3	40	42	
AD 6	AC 46	2,4	4,12	4,69	5,18	5,62	7,08	8,49	9,67	45	46	
AD 7	AC 46	3,230	5,49	6,40	7,10	7,84	10,16	12,43	14,33	55	53	
AD 1	AC 31	0,8	0,53	0,61	0,67	0,73	0,92	1,1	1,25	39	39	
AD 2	AC 31	1,02	0,82	0,93	1,03	1,12	1,41	1,69	1,92	87	95	
AD 3	AC 31	1,2	0,87	0,99	1,1	1,19	1,5	1,8	2,05	65	62	
AD 1	AC 35	0,8	0,53	0,61	0,67	0,73	0,92	1,1	1,25	34	40	
AD 2	AC 35	1,02	0,92	1,05	1,16	1,26	1,58	1,9	2,16	39	39	
AD 3	AC 35	1,2	1,28	1,46	1,61	1,75	2,2	2,64	3	44	42	
AD 4	AC 35	1,56	2,08	2,37	2,62	2,84	3,58	4,3	4,89	77	72	
AD 5	AC 35	2	2,62	2,98	3,3	3,58	4,51	5,41	6,16	37	34	
AD 2	AC 56	1,02	0,88	1	1,11	1,2	1,52	1,82	20,7	21	20	
AD 3	AC 56	1,2	1,19	1,36	1,5	1,63	2,05	2,46	2,8	28	32	
AD 4	AC 56	1,56	2,05	2,33	2,58	2,8	3,52	4,23	4,81	35	38	
AD 5	AC 56	2	3,46	3,94	4,36	4,73	5,96	7,15	8,14	43	40	
AD 6	AC 56	2,1	5,11	5,82	6,43	6,98	8,78	10,54	12	56	49	
AD 7	AC 56	2,3	6,87	7,81	8,64	9,38	11,8	14,17	16,12	68	64	



For Cropliner Slimline (shown here), Avoliners, Kiwiliners or Cropair 1000 Trailed please refer to Croplands customer service re new manual HT-OMCROPSLIM-E

SECTION 7

SPRAYING INFORMATION

CALIBRATION WORK SHEET

Fieni 920 DSV Fan ; Disk & Core Nozzles

Step 1

Check the Sprayer is in Good Working Order

Step 2

Determine Actual Speed of Travel

Measure and mark a straight path of 100 metres (or more) of travelling conditions similar to the orchard or vine yard you are going to spray.

Half fill the spray tank & record the time (in seconds) to travel the measured distance.

Make sure that the tractor is travelling at spraying speed when you pass the start and finish marks and ensure the fan and pump are at operational speed.

If you have a hectare metre or automatic controller you need to check the speed calibration of the controller.

Tractor model	
Gear	
Range	
Dual power	
Engine RPM	
Speed Km/h	

Kilometres per Hour = Distance traveled (m) x 3.6/time (seconds)

Step 3

Determine Spraying Volume Required

It is essential to determine the liquid volume per hectare required to effectively spray a crop without overspraying or underspraying.

Use your own experience or a registered rate calibration consultant to determine effective volume in litres per hectare.

..... litres/ha

Step 4

Determine Sprayer Configuration

Number of rows to be sprayed in one pass	= 1
Total number of nozzles to be used:	

Step 5

Determine ideal spray pressure (bar)

Step 6A, B, C

Determine & Select Nozzles

Determine nozzle flow rate required:

$$\frac{\text{Litres/Minute}}{\text{Litres/Ha} \times \text{Km/hr} \div 600 \div \text{Total Number of Nozzles Used} \times \text{Row Spacing (m)} \times \text{Number of Rows in One Pass}}$$

$$\frac{\text{ } \times \text{ } \div 600 \div \text{ } \times 1}{\text{ }} = \text{ } \text{ litres/minute/for all nozzles (divide by 2 for each half)}$$

Step 7

Fit & Test Selected Nozzles

The most important calibration is to test for actual litre per hectare.

Fill your spray tank to overflowing and run the sprayer for one minute, at the above operating settings, and record the total litres per minute used.

$$\frac{\text{Output/min/side (l/min)}}{\text{Output (litres)} \div \text{Time (minutes)}} = \text{ } \div \text{ } = \text{ } \text{ litres/minute}$$

Step 8

Calculate the Actual Application Rate

To calculate actual application rate (litres per hectare), use the following formula:

$$\text{Application Rate (l/ha)} = \frac{\text{Total Sprayer Output (l/min)} \times 600 \div \text{Speed (Km/hr)} \div \text{Row Spacing (m)} \div \text{Number Rows in One Pass}}{\text{ }} \times 600 \div \text{ } \div \text{ } \div 1 = \text{ } \text{ litres/ha}$$

DISCLAIMER:
Because of the many variable factors involved Croplands can not be held responsible for any downgrading or loss of crop resulting from the use of any information in this manual. This is issued as a guide only and subject to acceptance of this disclaimer.

Step 6D Calibration Work Sheet ; Fieni 920 DSV Fan ; Disk & Core Nozzles

Front Spray Ring					Rear Spray Ring				
Nozzle	Disc No.	Core No.	Discharge	Spray angle	Nozzle	Disc No.	Core No.	Discharge	Spray angle
Top 1					Top 8				
2					9				
3					10				
Middle 4					Middle 11				
5					12				
6					13				
Bottom 7					Bottom 14				
				one side =					one side =
Pressure				L/min FRONT Spray Ring	L/Min ALL NOZZLES				L/min REAR Spray Ring

SECTION 7

SPRAYING INFORMATION

CALIBRATION WORK SHEET

Fieni 920 DSV Fan ; Disk & Core Nozzles

Step 1

Check the Sprayer is in Good Working Order

Step 2

Determine Actual Speed of Travel

Measure and mark a straight path of 100 metres (or more) of travelling conditions similar to the orchard or vine yard you are going to spray.

Half fill the spray tank & record the time (in seconds) to travel the measured distance.

Make sure that the tractor is travelling at spraying speed when you pass the start and finish marks and ensure the fan and pump are at operational speed.

If you have a hectare metre or automatic controller you need to check the speed calibration of the controller.

Tractor model	
Gear	
Range	
Dual power	
Engine RPM	
Speed Km/h	

Kilometres per Hour = Distance traveled (m) x 3.6/time (seconds)

Step 3

Determine Spraying Volume Required

It is essential to determine the liquid volume per hectare required to effectively spray a crop without overspraying or underspraying.

Use your own experience or a registered rate calibration consultant to determine effective volume in litres per hectare.

..... litres/ha

Step 4

Determine Sprayer Configuration

Number of rows to be sprayed in one pass	= 1
Total number of nozzles to be used:	

Step 5

Determine ideal spray pressure (bar)

Step 6A, B, C

Determine & Select Nozzles

Determine nozzle flow rate required:

$$\frac{\text{Litres/Minute}}{\text{Litres/Ha} \times \text{Km/hr} \div 600 \div \text{Total Number of Nozzles Used} \times \text{Row Spacing (m)} \times \text{Number of Rows in One Pass}}$$

$$\text{.....} \times \text{.....} \div 600 \div \text{.....} \times 1$$

$$= \text{..... litres/minute/for all nozzles (divide by 2 for each half)}$$

Step 7

Fit & Test Selected Nozzles

The most important calibration is to test for actual litre per hectare.

Fill your spray tank to overflowing and run the sprayer for one minute, at the above operating settings, and record the total litres per minute used.

$$\frac{\text{Output/min/side (l/min)}}{\text{Output (litres)} \div \text{Time (minutes)}}$$

$$= \text{..... litres/minute}$$

Step 8

Calculate the Actual Application Rate

To calculate actual application rate (litres per hectare), use the following formula:

$$\text{Application Rate (l/ha)} = \frac{\text{Total Sprayer Output (l/min)} \times 600 \div \text{Speed (Km/hr)} \div \text{Row Spacing (m)} \div \text{Number Rows in One Pass}}{1}$$

$$= \text{..... litres/ha}$$

DISCLAIMER:
Because of the many variable factors involved Croplands can not be held responsible for any downgrading or loss of crop resulting from the use of any information in this manual. This is issued as a guide only and subject to acceptance of this disclaimer.

Step 6D Calibration Work Sheet ; Fieni 920 DSV Fan ; Disk & Core Nozzles

Front Spray Ring					Rear Spray Ring				
Nozzle	Disc No.	Core No.	Discharge	Spray angle	Nozzle	Disc No.	Core No.	Discharge	Spray angle
Top 1					Top 8				
2					9				
3					10				
Middle 4					Middle 11				
5					12				
6					13				
Bottom 7					Bottom 14				
				one side =					one side =
Pressure				L/min FRONT Spray Ring	L/Min ALL NOZZLES				L/min REAR Spray Ring

SECTION 7

SPRAYING INFORMATION

CALIBRATION WORK SHEET

Fieni 1060 DSV Fan ; Disk & Core Nozzles

Step 1

Check the Sprayer is in Good Working Order

Step 2

Determine Actual Speed of Travel

Measure and mark a straight path of 100 metres (or more) of travelling conditions similar to the orchard or vine yard you are going to spray.

Half fill the spray tank & record the time (in seconds) to travel the measured distance.

Make sure that the tractor is travelling at spraying speed when you pass the start and finish marks and ensure the fan and pump are at operational speed.

If you have a hectare metre or automatic controller you need to check the speed calibration of the controller.

Tractor model	
Gear	
Range	
Dual power	
Engine RPM	
Speed Km/h	

Kilometres per Hour = Distance traveled (m) x 3.6/time (seconds)

Step 3

Determine Spraying Volume Required

It is essential to determine the liquid volume per hectare required to effectively spray a crop without overspraying or underspraying.

Use your own experience or a registered rate calibration consultant to determine effective volume in litres per hectare.

..... litres/ha

Step 4

Determine Sprayer Configuration

Number of rows to be sprayed in one pass	= 1
Total number of nozzles to be used:	

Step 5

Determine ideal spray pressure (bar)

Step 6A, B, C

Determine & Select Nozzles

Determine nozzle flow rate required:

$$\frac{\text{Litres/Minute}}{\text{Litres/Ha} \times \text{Km/hr} \div 600 \div \text{Total Number of Nozzles Used} \times \text{Row Spacing (m)} \times \text{Number of Rows in One Pass}}$$

$$= \text{..... litres/minute/for all nozzles (divide by 2 for each half)}$$

Step 7

Fit & Test Selected Nozzles

The most important calibration is to test for actual litre per hectare.

Fill your spray tank to overflowing and run the sprayer for one minute, at the above operating settings, and record the total litres per minute used.

$$\frac{\text{Output/min/side (l/min)}}{\text{Output (litres)} \div \text{Time (minutes)}}$$

$$= \text{..... litres/minute}$$

Step 8

Calculate the Actual Application Rate

To calculate actual application rate (litres per hectare), use the following formula:

$$\frac{\text{Application Rate (l/ha)}}{\text{Total Sprayer Output (l/min)} \times 600 \div \text{Speed (Km/hr)} \div \text{Row Spacing (m)} \div \text{Number Rows in One Pass}}$$

$$= \text{..... litres/ha}$$

DISCLAIMER:
Because of the many variable factors involved Croplands can not be held responsible for any downgrading or loss of crop resulting from the use of any information in this manual. This is issued as a guide only and subject to acceptance of this disclaimer.

Step 6D Calibration Work Sheet ; Fieni 1060 DSV Fan ; Disk & Core Nozzles

◀ Front Spray Ring					Rear Spray Ring				
Nozzle	Disc No.	Core No.	Discharge	Spray angle	Nozzle	Disc No.	Core No.	Discharge	Spray angle
Top 1					Top 9				
2					10				
3					11				
Middle 4					Middle 12				
5					13				
6					14				
7					Bottom 15				
Bottom 8					Note the rear spray ring has 1 less nozzle				
one side =					one side =				
Pressure					L/Min ALL NOZZLES				
L/min FRONT Spray Ring					L/min REAR Spray Ring				

SECTION 7

SPRAYING INFORMATION

CALIBRATION WORK SHEET

Fieni 1060 DSV Fan ; Disk & Core Nozzles

Step 1

Check the Sprayer is in Good Working Order

Step 2

Determine Actual Speed of Travel

Measure and mark a straight path of 100 metres (or more) of travelling conditions similar to the orchard or vine yard you are going to spray.

Half fill the spray tank & record the time (in seconds) to travel the measured distance.

Make sure that the tractor is travelling at spraying speed when you pass the start and finish marks and ensure the fan and pump are at operational speed.

If you have a hectare metre or automatic controller you need to check the speed calibration of the controller.

Tractor model	
Gear	
Range	
Dual power	
Engine RPM	
Speed Km/h	

Kilometres per Hour = Distance traveled (m) x 3.6/time (seconds)

Step 3

Determine Spraying Volume Required

It is essential to determine the liquid volume per hectare required to effectively spray a crop without overspraying or underspraying.

Use your own experience or a registered rate calibration consultant to determine effective volume in litres per hectare.

..... litres/ha

Step 4

Determine Sprayer Configuration

Number of rows to be sprayed in one pass	= 1
Total number of nozzles to be used:	

Step 5

Determine ideal spray pressure (bar)

Step 6A, B, C

Determine & Select Nozzles

Determine nozzle flow rate required:

$$\frac{\text{Litres/Minute}}{\text{Litres/Ha} \times \text{Km/hr} \div 600 \div \text{Total Number of Nozzles Used} \times \text{Row Spacing (m)} \times \text{Number of Rows in One Pass}}$$

$$= \text{.....} \text{ litres/minute/for all nozzles (divide by 2 for each half)}$$

Step 7

Fit & Test Selected Nozzles

The most important calibration is to test for actual litre per hectare.

Fill your spray tank to overflowing and run the sprayer for one minute, at the above operating settings, and record the total litres per minute used.

$$\frac{\text{Output/min/side (l/min)}}{\text{Output (litres)} \div \text{Time (minutes)}}$$

$$= \text{.....} \text{ litres/minute}$$

Step 8

Calculate the Actual Application Rate

To calculate actual application rate (litres per hectare), use the following formula:

$$\frac{\text{Application Rate (l/ha)}}{\text{Total Sprayer Output (l/min)} \times 600 \div \text{Speed (Km/hr)} \div \text{Row Spacing (m)} \div \text{Number Rows in One Pass}}$$

$$= \text{.....} \text{ litres/ha}$$

DISCLAIMER:
Because of the many variable factors involved Croplands can not be held responsible for any downgrading or loss of crop resulting from the use of any information in this manual. This is issued as a guide only and subject to acceptance of this disclaimer.

Step 6D Calibration Work Sheet ; Fieni 1060 DSV Fan ; Disk & Core Nozzles

◀ Front Spray Ring					Rear Spray Ring				
Nozzle	Disc No.	Core No.	Discharge	Spray angle	Nozzle	Disc No.	Core No.	Discharge	Spray angle
Top 1					Top 9				
2					10				
3					11				
Middle 4					Middle 12				
5					13				
6					14				
7					Bottom 15				
Bottom 8					Note the rear spray ring has 1 less nozzle				
one side =					one side =				
Pressure					L/Min ALL NOZZLES				
L/min FRONT Spray Ring					L/min REAR Spray Ring				

SECTION 7

SPRAYING INFORMATION

CALIBRATION WORK SHEET

Fieni 920 ; AlbuZ ATR

Step 1

Check the Sprayer is in Good Working Order

Step 2

Determine Actual Speed of Travel

Measure and mark a straight path of 100 metres (or more) of travelling conditions similar to the orchard or vine yard you are going to spray.

Half fill the spray tank & record the time (in seconds) to travel the measured distance.

Make sure that the tractor is travelling at spraying speed when you pass the start and finish marks and ensure the fan and pump are at operational speed.

If you have a hectare metre or automatic controller you need to check the speed calibration of the controller.

Tractor model	
Gear	
Range	
Dual power	
Engine RPM	
Speed Km/h	

Kilometres per Hour = Distance traveled (m) x 3.6/time (seconds)

Step 3

Determine Spraying Volume Required

It is essential to determine the liquid volume per hectare required to effectively spray a crop without overspraying or underspraying.

Use your own experience or a registered rate calibration consultant to determine effective volume in litres per hectare.

..... litres/ha

Step 4

Determine Sprayer Configuration

Number of rows to be sprayed in one pass	= 1
Total number of nozzles to be used:	

Step 5

Determine ideal spray pressure (bar)	
--------------------------------------	--

Step 6A, B, C

Determine & Select Nozzles

Determine nozzle flow rate required:

$$\frac{\text{Litres/Minute}}{\text{Litres/Ha} \times \text{Km/hr} \div 600 \div \text{Total Number of Nozzles Used} \times \text{Row Spacing (m)} \times \text{Number of Rows in One Pass}}$$

$$\frac{\text{ } \times \text{ } \div 600 \div \text{ } \times 1}{\text{ }} = \text{ } \text{ litres/minute/for all nozzles (divide by 2 for each half)}$$

Step 7

Fit & Test Selected Nozzles

The most important calibration is to test for actual litre per hectare.

Fill your spray tank to overflowing and run the sprayer for one minute, at the above operating settings, and record the total litres per minute used.

$$\frac{\text{Output/min/side (l/min)}}{\text{Output (litres)} \div \text{Time (minutes)}} = \text{ } \div \text{ } = \text{ } \text{ litres/minute}$$

Step 8

Calculate the Actual Application Rate

To calculate actual application rate (litres per hectare), use the following formula:

$$\text{Application Rate (l/ha)} = \frac{\text{Total Sprayer Output (l/min)} \times 600}{\text{Speed (Km/hr)} \div \text{Row Spacing (m)} \div \text{Number Rows in One Pass}}$$

$$\text{ } \times 600 \div \text{ } \div \text{ } \div 1 = \text{ } \text{ litres/ha}$$

DISCLAIMER:
Because of the many variable factors involved Croplands can not be held responsible for any downgrading or loss of crop resulting from the use of any information in this manual. This is issued as a guide only and subject to acceptance of this disclaimer.

Step 6D Calibration Work Sheet ; Fieni 920 ; AlbuZ ATR

◀ Front Spray Ring				Rear Spray Ring			
Nozzle	ALBUZ Hollow Cone	Discharge	Spray angle	Nozzle	ALBUZ Hollow Cone	Discharge	Spray angle
Top 1				Top 8			
2				9			
3				10			
Middle 4				Middle 11			
5				12			
6				13			
Bottom 7				Bottom 14			
			one side =				one side =
			L/min FRONT Spray Ring				L/min REAR Spray Ring
			Pressure				L/Min ALL NOZZLES

SECTION 7

SPRAYING INFORMATION

CALIBRATION WORK SHEET

Fieni 920 ; Albus ATR

Step 1

Check the Sprayer is in Good Working Order

Step 2

Determine Actual Speed of Travel

Measure and mark a straight path of 100 metres (or more) of travelling conditions similar to the orchard or vine yard you are going to spray.

Half fill the spray tank & record the time (in seconds) to travel the measured distance.

Make sure that the tractor is travelling at spraying speed when you pass the start and finish marks and ensure the fan and pump are at operational speed.

If you have a hectare metre or automatic controller you need to check the speed calibration of the controller.

Tractor model	
Gear	
Range	
Dual power	
Engine RPM	
Speed Km/h	

Kilometres per Hour = Distance traveled (m) x 3.6/time (seconds)

Step 3

Determine Spraying Volume Required

It is essential to determine the liquid volume per hectare required to effectively spray a crop without overspraying or underspraying.

Use your own experience or a registered rate calibration consultant to determine effective volume in litres per hectare.

..... litres/ha

Step 4

Determine Sprayer Configuration

Number of rows to be sprayed in one pass	= 1
Total number of nozzles to be used:	

Step 5

Determine ideal spray pressure (bar)

Step 6A, B, C

Determine & Select Nozzles

Determine nozzle flow rate required:

$$\frac{\text{Litres/Minute}}{\text{Litres/Ha} \times \text{Km/hr} \div 600 \div \text{Total Number of Nozzles Used} \times \text{Row Spacing (m)} \times \text{Number of Rows in One Pass}}$$

$$= \frac{\text{ } \times \text{ } \div 600 \div \text{ } \times 1}{\text{ }} \text{ litres/minute/for all nozzles (divide by 2 for each half)}$$

Step 7

Fit & Test Selected Nozzles

The most important calibration is to test for actual litre per hectare.

Fill your spray tank to overflowing and run the sprayer for one minute, at the above operating settings, and record the total litres per minute used.

$$\frac{\text{Output/min/side (l/min)}}{\text{Output (litres)} \div \text{Time (minutes)}} = \text{ } \div \text{ } = \text{ } \text{ litres/minute}$$

Step 8

Calculate the Actual Application Rate

To calculate actual application rate (litres per hectare), use the following formula:

$$\text{Application Rate (l/ha)} = \frac{\text{Total Sprayer Output (l/min)} \times 600}{\text{Speed (Km/hr)} \div \text{Row Spacing (m)} \div \text{Number Rows in One Pass}}$$

$$= \text{ } \times 600 \div \text{ } \div \text{ } \div 1 = \text{ } \text{ litres/ha}$$

DISCLAIMER:
Because of the many variable factors involved Croplands can not be held responsible for any downgrading or loss of crop resulting from the use of any information in this manual. This is issued as a guide only and subject to acceptance of this disclaimer.

Step 6D Calibration Work Sheet ; Fieni 920 ; Albus ATR

◀ Front Spray Ring				Rear Spray Ring			
Nozzle	ALBUZ Hollow Cone	Discharge	Spray angle	Nozzle	ALBUZ Hollow Cone	Discharge	Spray angle
Top 1				Top 8			
2				9			
3				10			
Middle 4				Middle 11			
5				12			
6				13			
Bottom 7				Bottom 14			
			one side =				one side =
			L/min FRONT Spray Ring				L/min REAR Spray Ring
Pressure				L/Min ALL NOZZLES			

SECTION 7

SPRAYING INFORMATION

CALIBRATION WORK SHEET

Fieni 1060 ; Albus ATR

Step 1

Check the Sprayer is in Good Working Order

Step 2

Determine Actual Speed of Travel

Measure and mark a straight path of 100 metres (or more) of travelling conditions similar to the orchard or vine yard you are going to spray.

Half fill the spray tank & record the time (in seconds) to travel the measured distance.

Make sure that the tractor is travelling at spraying speed when you pass the start and finish marks and ensure the fan and pump are at operational speed.

If you have a hectare metre or automatic controller you need to check the speed calibration of the controller.

Tractor model	
Gear	
Range	
Dual power	
Engine RPM	
Speed Km/h	

Kilometres per Hour = Distance traveled (m) x 3.6/time (seconds)

Step 3

Determine Spraying Volume Required

It is essential to determine the liquid volume per hectare required to effectively spray a crop without overspraying or underspraying.

Use your own experience or a registered rate calibration consultant to determine effective volume in litres per hectare.

..... litres/ha

Step 4

Determine Sprayer Configuration

Number of rows to be sprayed in one pass	= 1
Total number of nozzles to be used:	

Step 5

Determine ideal spray pressure (bar)	
--------------------------------------	--

Step 6A, B, C

Determine & Select Nozzles

Determine nozzle flow rate required:

$$\frac{\text{Litres/Minute}}{\text{Litres/Ha} \times \text{Km/hr} \div 600 \div \text{Total Number of Nozzles Used} \times \text{Row Spacing (m)} \times \text{Number of Rows in One Pass}}$$

$$\text{.....} \times \text{.....} \div 600 \div \text{.....} \times 1$$

= litres/minute/for all nozzles
(divide by 2 for each half)

Step 6D Calibration Work Sheet ; Fieni 1060 ; Albus ATR

◀ Front Spray Ring				Rear Spray Ring			
Nozzle	ALBUZ Hollow Cone	Discharge	Spray angle	Nozzle	ALBUZ Hollow Cone	Discharge	Spray angle
Top 1				Top 9			
2				10			
3				11			
Middle 4				Middle 12			
5				13			
6				14			
7				Bottom 15			
Bottom 8				Note the rear spray ring has 1 less nozzle			
		one side =				one side =	
Pressure			L/min FRONT Spray Ring	L/Min ALL NOZZLES			L/min REAR Spray Ring

Step 7

Fit & Test Selected Nozzles

The most important calibration is to test for actual litre per hectare.

Fill your spray tank to overflowing and run the sprayer for one minute, at the above operating settings, and record the total litres per minute used.

$$\frac{\text{Output/min/side (l/min)}}{\text{Output (litres)} \div \text{Time (minutes)}} = \text{..... litres/minute}$$

Step 8

Calculate the Actual Application Rate

To calculate actual application rate (litres per hectare), use the following formula:

$$\text{Application Rate (l/ha)} = \frac{\text{Total Sprayer Output (l/min)} \times 600}{\text{Speed (Km/hr)} \div \text{Row Spacing (m)} \div \text{Number Rows in One Pass}}$$

$$\text{.....} \times 600 \div \text{.....} \div \text{.....} \div 1 = \text{..... litres/ha}$$

DISCLAIMER:

Because of the many variable factors involved Croplands can not be held responsible for any downgrading or loss of crop resulting from the use of any information in this manual. This is issued as a guide only and subject to acceptance of this disclaimer.

SECTION 7

SPRAYING INFORMATION

CALIBRATION WORK SHEET

Fieni 1060 ; Albuz ATR

Step 1

Check the Sprayer is in Good Working Order

Step 2

Determine Actual Speed of Travel

Measure and mark a straight path of 100 metres (or more) of travelling conditions similar to the orchard or vine yard you are going to spray.

Half fill the spray tank & record the time (in seconds) to travel the measured distance.

Make sure that the tractor is travelling at spraying speed when you pass the start and finish marks and ensure the fan and pump are at operational speed.

If you have a hectare metre or automatic controller you need to check the speed calibration of the controller.

Tractor model	
Gear	
Range	
Dual power	
Engine RPM	
Speed Km/h	

Kilometres per Hour = Distance traveled (m) x 3.6/time (seconds)

Step 3

Determine Spraying Volume Required

It is essential to determine the liquid volume per hectare required to effectively spray a crop without overspraying or underspraying.

Use your own experience or a registered rate calibration consultant to determine effective volume in litres per hectare.

..... litres/ha

Step 4

Determine Sprayer Configuration

Number of rows to be sprayed in one pass	= 1
Total number of nozzles to be used:	

Step 5

Determine ideal spray pressure (bar)

Step 6A, B, C

Determine & Select Nozzles

Determine nozzle flow rate required:

Litres/Minute

Litres/Ha x Km/hr ÷ 600 ÷ Total Number of Nozzles Used x Row Spacing (m) x Number of Rows in One Pass

x ÷ 600 ÷ x 1

= litres/minute/for all nozzles (divide by 2 for each half)

Step 7

Fit & Test Selected Nozzles

The most important calibration is to test for actual litre per hectare.

Fill your spray tank to overflowing and run the sprayer for one minute, at the above operating settings, and record the total litres per minute used.

$$\frac{\text{Output/min/side (l/min)}}{\text{Output (litres) ÷ Time (minutes)}} = \text{litres/minute}$$

Step 8

Calculate the Actual Application Rate

To calculate actual application rate (litres per hectare), use the following formula:

$$\text{Application Rate (l/ha)} = \frac{\text{Total Sprayer Output (l/min)} \times 600}{\text{Speed (Km/hr)} \div \text{Row Spacing (m)} \div \text{Number Rows in One Pass}}$$

x 600 ÷ ÷ 1 = litres/ha

DISCLAIMER:
Because of the many variable factors involved Croplands can not be held responsible for any downgrading or loss of crop resulting from the use of any information in this manual. This is issued as a guide only and subject to acceptance of this disclaimer.

Step 6D Calibration Work Sheet ; Fieni 1060 ; Albuz ATR

◀ Front Spray Ring				Rear Spray Ring			
Nozzle	ALBUZ Hollow Cone	Discharge	Spray angle	Nozzle	ALBUZ Hollow Cone	Discharge	Spray angle
Top 1				Top 9			
2				10			
3				11			
Middle 4				Middle 12			
5				13			
6				14			
7				Bottom 15			
Bottom 8				Note the rear spray ring has 1 less nozzle			
			one side =				one side =
			L/min FRONT Spray Ring				L/min REAR Spray Ring
			Pressure				L/Min ALL NOZZLES

SECTION 8

LUBRICATION & MAINTENANCE

GENERAL MAINTENANCE

All the various maintenance operations must be carried out after each use and when the machine is not in operation.

1. Remove any foreign bodies from the protective guards and replace any damaged ones.
2. No deposits should be allowed to accumulate on the fan. It must be cleaned with a pressurised water jet.
3. Remove from the various parts any residue of the chemical products used, as they could damage the materials.
4. Periodically check the jets and replace any worn nozzles.
5. Before the winter period, completely empty the nozzle-holding tubes of liquids, in order to safeguard against their breaking.
6. Have the sprayer unit checked once a year by qualified technical personnel.
7. Repairs should only be undertaken by suitably qualified personnel.

If replacing a damaged fan blade it is necessary to balance the fan. Do not operate with damaged fan blades.



GREASING & SERVICE PROCEDURES	94
EVERY 200 HOURS	94
GREASE POINTS	94
DIAPHRAGM PUMPS	95
FILTERS	96

SECTION 8

LUBRICATION & MAINTENANCE

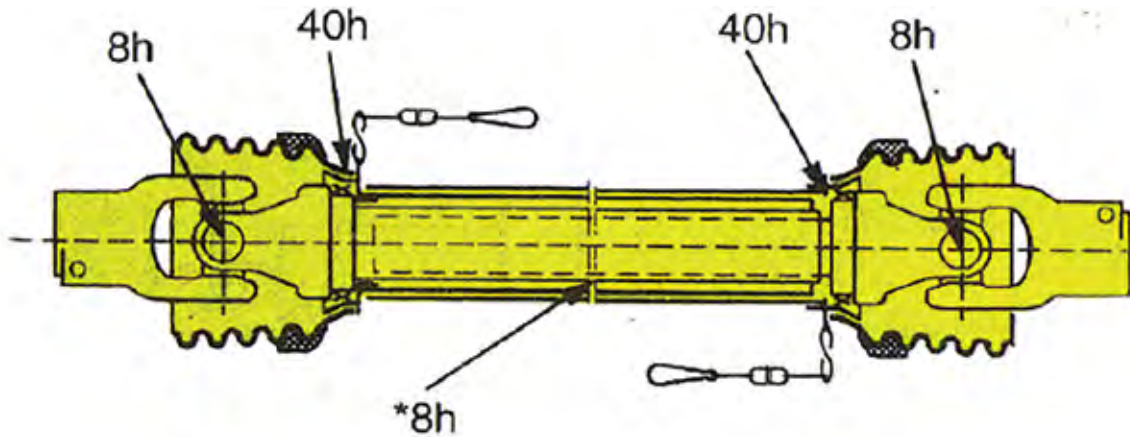

Grease the PTO shaft as shown. * Pull shaft apart - apply grease to the inside of the outer telescopic profile.

GREASING & SERVICE PROCEDURES

1. Clean suction line filter after completion of each tank.
2. Clean pressure line filter regularly.
3. Check tyre pressure ((350kPa / 50 psi), and check wheel nuts.
4. Clean Rapid-check flowmeter (refer to page 71), if fitted.
5. Grease tractor to sprayer PTO universal joints every 8 hours. Grease lightly until grease becomes firm in seals. Over greasing will break seals and allow dust and moisture to penetrate - increasing wear.
6. Grease PTO inner tubes every 8 hours. To lubricate the inner tube, slide PTO shaft apart, clean the telescopic tubes, grease and reassemble.
7. Grease the PTO covers every 40 hours.
8. Ensure safety covers and safety chains are in place and in good working order
9. Check pump air chamber pressure on a regular basis. As a general guideline it should be 10%-20% of operating pressure (70-100 kPa [10-15 psi]). Refer to pump manual for more information.
10. To ensure trouble free spraying, flush the sprayer with fresh water thoroughly each day, and before changing chemicals. Dispose of tank wash according to chemical manufacturers instructions.
11. Grease all joints, height adjusting points and other grease points.

EVERY 200 HOURS

1. Lubricate quick release lock pins on PTO shaft.
2. Re-pack wheel bearings with grease.
3. Grease and check & adjust castellated nut both LH & RH of walking beam axle.
4. Grease all tank lid seals with vaseline.
5. Check to ensure agitators have not become blocked with sulphur/chemicals.
6. Check pump mounts.
7. Check fan RPM and oil pressure at test port.

GREASE POINTS



Grease all swivel drawbar grease points

1. Swivel eye on drawbar, if fitted.
2. Wheel hubs, if fitted with grease nipples.

SECTION 8

LUBRICATION & MAINTENANCE



Grease wheel hubs

3. PTO shaft - all crosses (knuckles), both ends and sliding tubes. Refer to page 41-42 for frequency.

DIAPHRAGM PUMPS

Diaphragm Pumps Maintenance

Annovi & Reverberi (A&R) pumps are of the piston-diaphragm type. All parts in contact with the spray liquid, which are subject to corrosion, are protected, making them ideal for spraying.

Daily Before Starting the Pump

1. Check that oil is visible in sight glass (half way up) and top up if necessary with good clean motor oil 20W/30 or 20W/40.
2. Clean all sprayer filters. Blocked or semi blocked filters place extra stress on diaphragms.
3. Start with zero pressure and the pump will self prime immediately and clear air locks in suction line.



AR185 - 180l/min diaphragm pump

Daily after Use

1. Flush pump with clean water.
2. Drain filters and clean. A high percentage of pump failures are due to blocked filters.

Every 50 Hours

Check surge chamber pressure and adjust as follows:

- Air pressure 70-100kPa (10-15psi) [Should be 10-20% of operating pressure].

Vibration of the delivery hose usually indicates that the air pressure in the surge chamber is incorrect.

The main cause of surge chamber diaphragm fracture is low pressure in this chamber.

Surge chamber pressure can be checked with an ordinary tyre gauge.

The above pressure range is a guide to the correct pressure.



Running a diaphragm pump faster than specified will not improve performance, but will damage and wear out moving parts. Warranty will be made void by speeds in excess of those indicated on the pump name plate.

However, if difficulties recur, adjust the pressure until an even flow is obtained from the pump (no pulsing of liquid at operating RPM). The pressure is best increased with a bicycle pump, hand pump or foot pump.

Every 250 hours or Every Season - Whichever Comes Sooner

1. Change oil and refill with 20W/30 oil. Attention should be made to remove trapped air behind the diaphragms by rocking from side to side as instructed.

It is also good practise run the pump for 10 minutes without pressure, and then, top up with oil before working the pump.

2. When changing the pump oil, check diaphragms and replace them if they are showing signs of wear.

Diaphragm valves should be replaced every 400 hours regardless of wear.

This is normally a pre-season maintenance procedure which can be done easily as no special tools are required.

You can avoid unnecessary down time in spraying seasons by carrying out preventative maintenance.

SECTION 8

LUBRICATION & MAINTENANCE

3. Also check inlet and outlet valves and replace if worn. Worn valves not only reduce the output of the pump, but may reduce the life of the diaphragms.

Excessive Diaphragm Failure

If you have excessive diaphragm failure check the following points. These will cause failure of diaphragms due to added stress or chemical attack.

1. Most Important - Pump not being flushed out daily with clean water after use.
2. Oil level too low allowing air between piston and diaphragm.
3. Air leaks in suction line.
4. Restricted suction line.
5. Restriction through suction filter.
6. Not cleaning suction filter regularly.
7. Worn suction and discharge valves.
8. Bypass line too small to carry full capacity of pump.
9. In cold climates - frozen suction/discharge lines or water remaining in the pump after flushing.
10. Incorrect air setting or no air in air chamber.
11. Agitator excessively restricting bypass from pump.
12. Diaphragm material construction incorrect for chemical or solution being pumped.
13. Chemicals containing toluene or other aggressive solvents may require viton diaphragms - particularly if the pump is not properly flushed after use.

Pre-Season Servicing

For thorough pre-season servicing - check all aspects of the Cropliner and its operating components as outlined in the pre-delivery check list.

Pump Storage and Corrosion Protection

1. Warm Climates

If you operate in a warm climate with no chance of frost in the winter, you will not have any problems with frost damage.

If you are storing your sprayer between seasons, ensure your pump has been thoroughly flushed with clean water. A good idea is to run a mixture of 1% solution of summer mineral spraying oil through the pump and plumbing system. Summer spraying oil is water-soluble oil such as DC-Tron. This will coat and protect all internal pump parts. Ensure this mixture is flushed out before spraying commences in the new season.

2. Cold Climates

For prolonged storage, an anti-freeze mixture can be flushed through the pump. Ensure this is thoroughly flushed out prior to the commencement of spraying again.

If the pump is being stored overnight and a risk of freezing is imminent, drain all liquid from the pump and lines, including boom lines.

FILTERS

Filter Maintenance

Clean filters ensure that no solids enter the spraying system to block or damage pump or nozzles.

All filters should be cleaned regularly or after each spraying period.



The pump suction valve CLOSED to the main tank

Suction Filter

The suction filter should be cleaned regularly, or after each spray tank has been emptied.

To clean the filter:

1. Completely stop all sprayer functions.
2. Place the tank selection valve in the closed position to shut off liquid from the main tank.
3. Remove the outer filter screw and bowl.
4. Remove the filter screen & thoroughly clean it and other components before reassembling the filter.

SECTION 8

LUBRICATION & MAINTENANCE



Remove the outer filter screw and bowl



Remove & clean the filter element & components

5. Carefully reassemble the filter, ensuring the screen O-Rings are in place, and then, tighten the outer filter screw so that the outer O-ring is properly sealed.



Reassemble and tighten the outer filter screw.



Open & close the filter tap while system is pressurised

6. **Open the tank selection valve** to access liquid from the main tank, then check the filter is sealed correctly. If leaking, further tighten the outer screw until sealed. If this does not stop the leaking, check the alignment of the O-ring and/or the condition of the O-ring. Replace if necessary.
Vaseline is the best lubricant for filter seals.

NOTE

Be careful not to damage or deform the mesh or O-ring while cleaning and refitting the suction filter. If the filter screen or O-ring is damaged, replace the part.

CAUTION

Ensure the **TANK SELECTION VALVE IS OPEN** before starting the pump. Starting the pump with the Tank Selection valve closed will seriously damage the suction valve and warranty will be made void.

SECTION 8

LUBRICATION & MAINTENANCE

Pressure filters

Clean the Pressure Filter regularly. Clean at least daily or more often if the water source isn't clean, and whenever freshwater flushing.



In-line Pressure Filters (if fitted)

The in-line pressure filter should be cleaned regularly, or after each spray tank has been emptied.

To flush each filter, open and close the filter tap while system is pressurised.

The filter & bowl assembly will need to be disassembled for thorough cleaning.



Non-Drip Diaphragms

Non-drip diaphragms should be cleaned regularly to prevent dripping from nozzles.

To clean the non-drip diaphragms:

1. Completely stop all sprayer functions.
2. Unscrew and remove the diaphragm cap.
3. Remove and clean any sediment off the diaphragm membrane. Replace the diaphragm membrane if damaged.
4. Replace the diaphragm.
5. Refit the diaphragm cap and carefully tighten.



SECTION 9

TROUBLESHOOTING

DIAPHRAGM PUMP PROBLEMS

PROBLEM	PROBABLE CAUSE	REMEDY
A. Pump does not draw or deliver liquid. Pressure gauge fluctuates badly	<ol style="list-style-type: none"> 1. The pump is sucking in air through suction line. 2. Air has not been entirely evacuated from the pump. 3. Blocked suction filter. 4. Damaged or worn suction valves. 	<ol style="list-style-type: none"> 1. Examine the suction hose and ensure it is firmly secured. 2. Rotate the pump with outlet hose and taps open. 3. Clean suction filter. 4. Replace suction valves.
B. Liquid flow is irregular (Also check items under A)	<ol style="list-style-type: none"> 1. The air in the air chamber of the pump is incorrectly set. 2. Diaphragm split. 3. Damaged or worn valves. 4. Foreign matter holding valves open. 	<ol style="list-style-type: none"> 1. Check pressure in air chamber of pump. Set as required (refer p.49). 2. Replace diaphragm. 3. Replace valves. 4. Clean valves.
C. Pump delivers insufficient pressure	<ol style="list-style-type: none"> 1. Regulating valve: <ul style="list-style-type: none"> • Sticking open • Not set for pressure • Damaged or worn seat or spring 2. Cylinder diaphragm ruptured. 3. Pump valves blocked, worn or damaged. 4. Spray nozzles worn, missing or exceed pump capacity. 	<ol style="list-style-type: none"> 1. Fix the regulator: <ul style="list-style-type: none"> • Unstick/renew the valves • Set the pressure • Replace the spring 2. Replace diaphragms. 3. Unblock valves and or replace. 4. Replace spray nozzles with appropriate size.
D. Output drops & pump is noisy	<ol style="list-style-type: none"> 1. Blocked suction lines or filter screen. 	<ol style="list-style-type: none"> 1. Check and clean as required.
E. Oil being discharged through delivery line or discoloured oil in sight glass of pump	<ol style="list-style-type: none"> 1. One or more diaphragms split or ruptured. 	<ol style="list-style-type: none"> 1. Immediately drain oil from pump and flush to remove all spray residues from sump. Remove pump heads & fit new diaphragms. Fill to correct level with oil as per pump manual.

SECTION 9

TROUBLESHOOTING

DIAPHRAGM PUMP PROBLEMS

PROBLEM	PROBABLE CAUSE	REMEDY
SUCTION SIDE OF PUMP		
F. Suction hose vibration... / hunting	1. Air getting into suction.	1. Check suction lines for leaks.
G. Pump valves hammering	1. Suction tap partly turned off. 2. Suction strainer(s) blocked.	1. Seal all joints securely with tape or stag. Firm up clamps. 2. Check the suction filter is sealed.
H. No water flow in suction hose	1. Suction Tank Selection Valve turned off. 2. Suction strainer(s) blocked.	1. Turn valve fully on. 2. Clean filters.
DISCHARGE SIDE OF PUMP		
I. Manual regulator valve leaking from spindle	1. Split diaphragm or O-rings.	1. Remove 4 body set screws, replace diaphragm and O-rings.
J. Pressure gauge showing correct working pressure no pressure at nozzle	1. Faulty solenoids. 2. Blocked discharge filter where fitted. 3. Ants, wasps build nests in discharge line or nozzles.	1. Service or replace. 2. Clean discharge filter. 3. Clean nozzles of foreign materials with tooth brush.

SECTION 9

TROUBLESHOOTING

GENERAL SPRAYER PROBLEMS

PROBLEM	PROBABLE CAUSE	REMEDY
1. No spray when turned on	<ol style="list-style-type: none"> 1. Filter on the inlet side of the pump blocked. 2. Faulty pump. 3. Control valves not working 	<ol style="list-style-type: none"> 1. Dismantle, clean & re-assemble. 2. Change pump. 3. Check all motor valves and manual Pressure Regulating Valve.
2. Sprays for short time only	<ol style="list-style-type: none"> 1. Air inlet to tank blocked. 2. Filter on suction side of pump blocking or blocked. 	<ol style="list-style-type: none"> 1. Clean air vent. 2. Dismantle, clean & re-assemble the filter. If filter problem persists, clean out the tank & start again.
3. Spray pattern is uneven	<ol style="list-style-type: none"> 1. Blocked nozzles. 2. Nozzle tips worn. 3. Different pressure at nozzles; wrong nozzles fitted. 	<ol style="list-style-type: none"> 1. Remove, clean & check. Check output & for streaks. 2. Check nozzle output, replace worn nozzles. 3. Remove a nozzle in each section & check that flow rate is the same. If different, check for blockages.
4. Pressure going up - output going down	<ol style="list-style-type: none"> 1. Blocked nozzles. 2. Pressure filter blocking. 	<ol style="list-style-type: none"> 1. Dismantle, clean & refit. Check pressure returns to normal. Check all filters and spray mixture. 2. Check & clean the pressure filter.
5. Pressure falling	<ol style="list-style-type: none"> 1. Filter on suction side blocked. 2. Nozzle tips worn. 3. Pressure gauge faulty. 4. Pump worn. 5. Worn manual PRV (pressure regulating valve) 	<ol style="list-style-type: none"> 1. Dismantle & clean the filter. 2. Check nozzle output, replace worn nozzles. 3. Check with new pressure gauge. 4. Repair or replace the pump. 5. Replace PRV
6. Spray pattern narrow or faltering	<ol style="list-style-type: none"> 1. Pressure too low. 2. Nozzles blocked or partially blocked. 	<ol style="list-style-type: none"> 1. Check that the correct nozzles are being used... check and clean.. 2. Check that the tank is not empty. If not, there is an air leak between the pump & tank or in the pump. Check plumbing & repair.
7. Foam in the tank	<ol style="list-style-type: none"> 1. Too much agitation. 	<ol style="list-style-type: none"> 1. Switch Off one or both agitators.

SECTION 9

TROUBLESHOOTING

MOTOR VALVE PROBLEMS

PROBLEM	PROBABLE CAUSE	REMEDY
1. Section line valve opens when it should be closed and closes when it should be open.	1. Wiring incorrect.	1. Reverse polarity of valve by changing wires at the valve cap.
2. Water leaks past valve when valve is shut.	1. Worn seat.	1. Replace seat/hosetail and/or valve system if necessary.
3. Valve won't operate.	1. No power to valve. 2. Motor failure. 3. Valve clogged.	1. Check all connections, supply - loom. 2. Replace motor. 3. Clean internals of valve and/or put a new valve kit in the valve.
4. Servo valve not regulating flow.	1. Valve jamming. 2. No power. 3. Power clogged.	1. Clean out valve or replace. 2. Check all power leads and supply, or replace motor. 3. Clean out valve and/or put a new valve kit in the valve.
5. Dump valve not releasing pressure in system on shut-off.	1. No power to valve. 2. Valve motor failed. 3. Dump-line blocked.	1. Check power supply and all connections. 2. Check motor and replace if required. 3. Clean valve and return line.

OTHER PROBLEMS

PROBLEM	PROBABLE CAUSE	REMEDY

SECTION 10

ASSEMBLY DRAWINGS, PARTS & SCHEMATICS

ALL PARTS INFORMATION is now listed on the Croplands website:

- Go to croplands.com.au
- Search in the Parts Information section linked to the home page.

NOTE

Drawings are for illustration purpose only - refer to sprayer for actual plumbing. Parts listed are indicative of the sprayer type.

Items in italics or without a part number are non stocked items and may need to be specially ordered.

For further parts information refer to: www.croplands.com.au

NOTE

Contact Croplands Technical Support
for further information:
1300 650 724

CROPLINER 5000/ 1060DSV TANDEM AXLE	104
CROPLINER 5000/ 1060DSV SINGLE AXLE	105
CROPLINER 4000/ 1060DSV	106
CROPLINER 4000/ 920DSV	107
CROPLINER 3000/ 920DSV	108
CROPLINER 2000/ 920DSV	109
CROPLINER 1500/ 920DSV	110
PLUMBING SCHEMATICS	111
ELECTRICAL SCHEMATICS	116
PTO SHAFT OPTIONS	120
MISCELLANEOUS	121

SECTION 10

ASSEMBLY DRAWINGS, PARTS & SCHEMATICS

CROPLINER 5000/1060DSV TANDEM AXLE

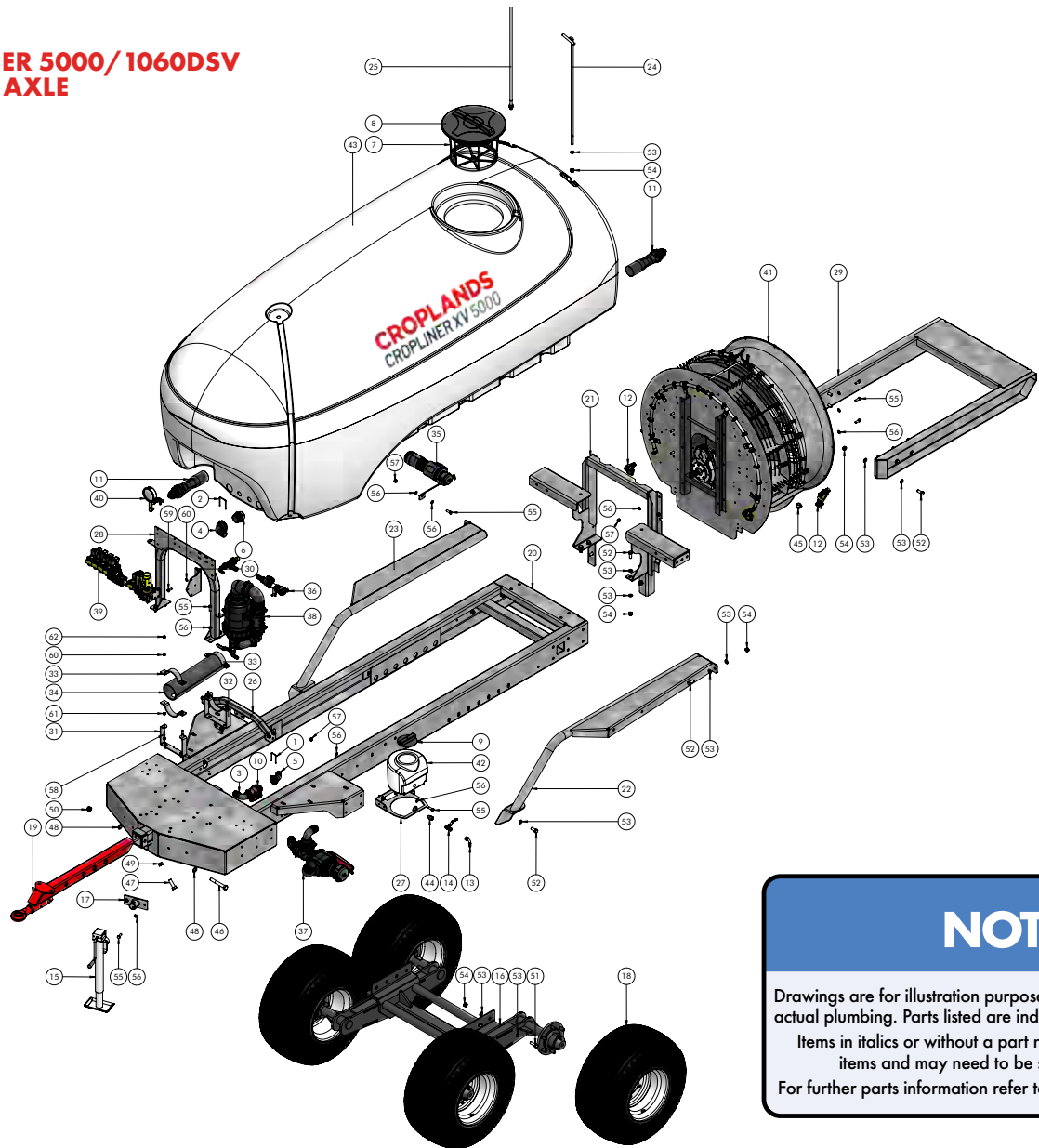

NOTE

Drawings are for illustration purpose only - refer to sprayer for actual plumbing. Parts listed are indicative of the sprayer type.

Items in *italics* or without a part number are non stocked items and may need to be specially ordered.

For further parts information refer to: www.croplands.com.au

ITEM NO.	PART NUMBER	DESCRIPTION	QTY.
1	A010005	INLET FORK	2
2	A010007	FORK D.5 INTERN 0.59 T7	1
3	A1190540	ELBOW T5F D.40	1
4	A1190740	ELBOW T7F D.40	1
5	A1192535	ELBOW 45DEG T5F D.35	1
6	A249177	BULKHEAD T7M 2" SHORT	1
7	A300130	FILTER BASKET LARGE 254MM DEEP	1
8	A3510060	LID/RING KIT 455MM	1
9	A3522000	BREATHER FOR 355MM & 455MM LID	1
10	A45514405	BALL VALVE 1 1/4" 2 WAY TMS	1
11	A502163	AGITATOR	2
12	B146.504.1070	FILTER M146 70MESH	4
13	B163.604.13	ELBOW 1/2" C/W HEX NUT 1/2"	1
14	B165.1501.7	BALL VALVE 1/2" X 1/2" LH	1
15	BP-184	JOCKEY STAND LONG PINTO	1
16	BP-400Y	WALKING BEAM AXLE BTON	1
17	HP-006	SPIGOT PLATE JACK STAND	1
18	HP-202GA	WHEEL/TYRE 400X15.5 NO OFFSET	4
19	HP-400A	DRAWBAR LONG	1
20	HP-750-1	CHASSIS 5000LT AIRBLAST	1
21	HP-750-2	FAN & TANK BRACKET 5000LT POLY CROPLINER	1
22	HP-750-3L	TANK SIDE RAIL LH 5000LT	1
23	HP-750-3R	TANK SIDE RAIL RH 5000LT	1
24	HP-750-4L	REAR TIE DOWN ROD LH 5000LT	1
25	HP-750-4R	REAR TIE DOWN ROD RH 5000LT	1
26	HP-750-5	FRONT TANK SUPPORT 5000LT	1
27	HP-750-6	TANK CRADLE 10LT	1
28	HP-750-7	VALVE BRACKET 5000LT CROPLINER	1
29	HP-750-8	BUMPER LEAF SHIELD 5000LT	1
30	HP-750-9	FILTER MOUNT 3" 5000LT	1
31	HP-750-10	FRONT BRACKET SHAFT GUARD	1
32	HP-750-11	REAR BRACKET SHAFT GUARD	1
33	HP-750-12	CLAMP T27MM E16-127H	4
34	HP-750-13	SHAFT GUARD 127 X 8 POLY PIPE	1
35	KH-4100-9	BOTTOM FILL PLUMBING KIT	1
36	KH-4100-10	SUCTION PROBE PLUMBING KIT	1
37	KH-4300-1	CROP 5000 SUCTION VALVE ASSY COMET	1
38	KH-4300-2	CROP 5000 SUCTION FILL ASSY COMET	1
39	KH-4300-3	CROP 5000 PRESSURE MANIFOLD ASSY	1
40	KH-4300-4	CROP 5000 GAUGE ASSY	1
41	KH-5040	FAN ASSEMBLY 1060	1
42	P300-10L	10LT HAND WASH TANK TO SUIT 300LT	1
43	P5000AB-RAW	TANK 5000LT POLY AIRBLAST RAW	1
44	TFAD1212FM	ADAPTOR 1/2" BSPF X 1/2" BSPM	1
45	TFEL1212MF	ELBOW 1/2" BSPM X 1/2" BSPF	4
46	M20X140BOLT	M20 X 140 HEX HEAD BOLT HT ZP	1
47	M20X60	M20 X 60 SET SCREW HT ZP	2
48	M20FWASHER	M20 FLAT WASHER ZP	2
49	M20HNUT	M20 HALF NUT ZP	2
50	M20NNUT	M20 NYLOC NUT HT ZP	1
51	M16X50	M16 X 50 HEX HEAD SET SCREW HT ZP	8
52	M16X40	M16 X 40 HEX HEAD SET SCREW	26
53	M16FWASHER	M16 FLAT WASHER ZP	70
54	M16NNUT	M16 NYLOC NUT HT ZP	36
55	M12X35	M12 X 35 SET SCREW HT ZP	19
56	M12FWASHER	M12 FLAT WASHER ZP	38
57	M12NNUT	M12 NYLOC NUT HT ZP	19
58	M10X60BOLT	M10 X 60 BOLT HT ZP	4
59	M10X30	M10 X 30 SET SCREW HT ZP	7
60	M10FWASHER	M10 FLAT WASHER ZP	22
61	M10HNUT	M10 HEX NUT HT ZP	4
62	M10NNUT	M10 NYLOC NUT HT ZP	11

SECTION 10

ASSEMBLY DRAWINGS, PARTS & SCHEMATICS

**CROPLINER 5000/1060DSV
SINGLE AXLE**

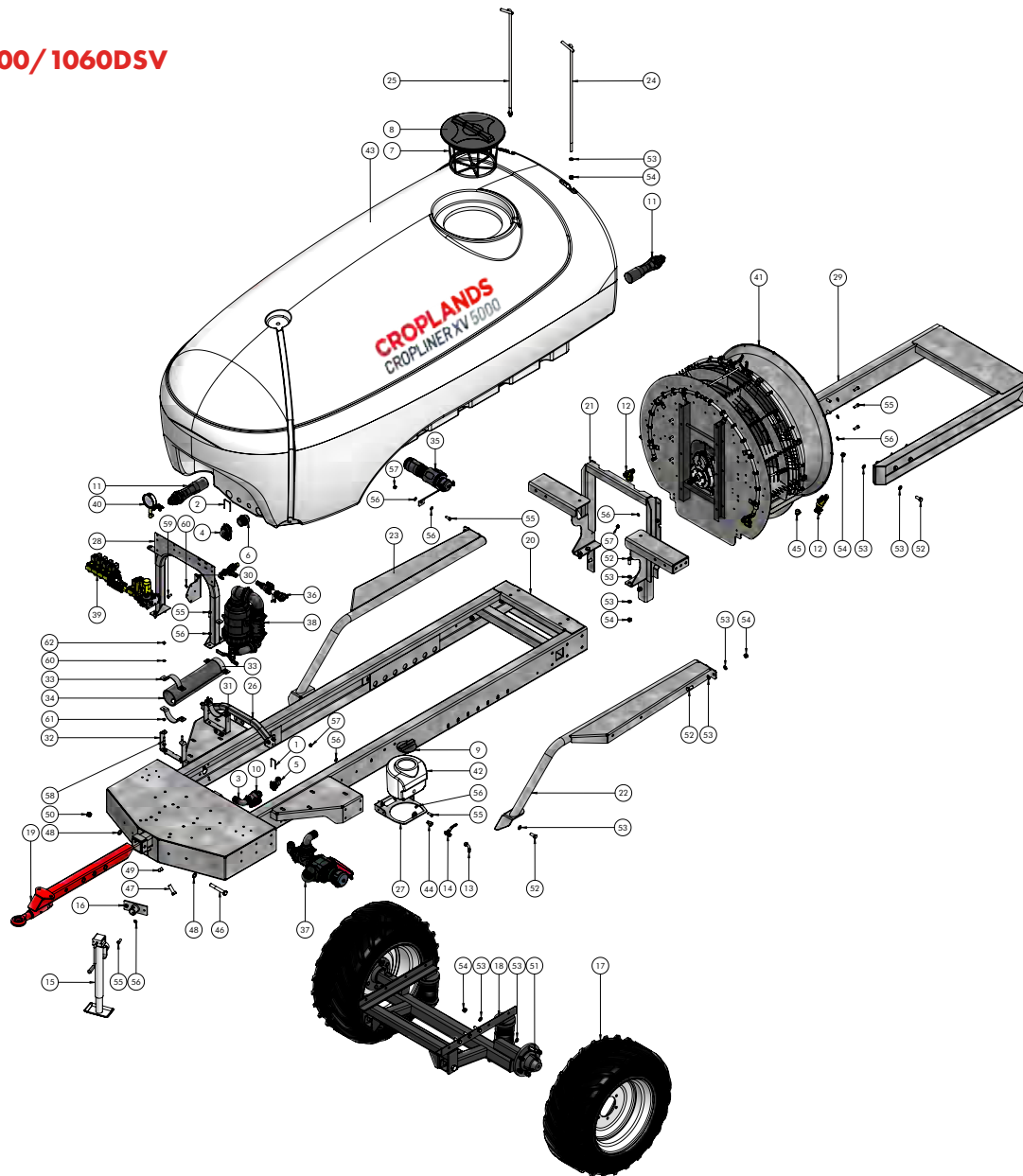

ITEM NO.	PART NUMBER	DESCRIPTION	QTY.
1	A010005	INLET FORK	2
2	A010007	FORK D.5 INTERN 0.59 T7	1
3	A1190540	ELBOW 15F D.40	1
4	A1190740	ELBOW 17F D.40	1
5	A1192535	ELBOW 45DEG 15F D.35	1
6	A249177	BULKHEAD 17M 2" SHORT	1
7	A300130	FILTER BASKET LARGE 254MM DEEP	1
8	A3510060	LID/RING KIT 455MM	1
9	A3522000	BREATHER FOR 355MM & 455MM LID	1
10	A45514405	BALL VALVE 1 1/4" 2 WAY TMS	1
11	A502163	AGITATOR	2
12	B146.504.1070	FILTER M146 70MESH	4
13	B163.604.13	ELBOW 1/2" C/W HEX NUT 1/2"	1
14	B165.1501.7	BALL VALVE 1/2" X 1/2" LH	1
15	BP-184	JOCKEY STAND LONG PINTO	1
16	HP-006	SPIGOT PLATE JACK STAND	1
17	HP-202H	TYRE & WHEEL 400 X 22.5 HEAVY DUTY	2
18	HP-234CLA	SUSPENSION SINGLE AXLE 4000LT	1
19	HP-400A	DRAWBAR LONG	1
20	HP-750-1	CHASSIS 5000LT AIRBLAST	1
21	HP-750-2	FAN & TANK BRACKET 5000LT POLY CROPLINER	1
22	HP-750-3L	TANK SIDE RAIL LH 5000LT	1
23	HP-750-3R	TANK SIDE RAIL RH 5000LT	1
24	HP-750-4L	REAR TIE DOWN ROD LH 5000LT	1
25	HP-750-4R	REAR TIE DOWN ROD RH 5000LT	1
26	HP-750-5	FRONT TANK SUPPORT 5000LT	1
27	HP-750-6	TANK CRADLE 10LT	1
28	HP-750-7	VALVE BRACKET 5000LT CROPLINER	1
29	HP-750-8	BUMPER LEAF SHIELD 5000LT	1
30	HP-750-9	FILTER MOUNT 3" 5000LT	1
31	HP-750-11	REAR BRACKET SHAFT GUARD	1
32	HP-750-10	FRONT BRACKET SHAFT GUARD	1
33	HP-750-12	CLAMP 127MM E16-127H	4
34	HP-750-13	SHAFT GUARD 127 X 8 POLY PIPE	1
35	KH-4100-9	BOTTOM FILL PLUMBING KIT	1
36	KH-4100-10	SUCTION PROBE PLUMBING KIT	1
37	KH-4300-1	CROP 5000 SUCTION VALVE ASSY COMET	1
38	KH-4300-2	CROP 5000 SUCTION FILL ASSY COMET	1
39	KH-4300-3	CROP 5000 PRESSURE MANIFOLD ASSY	1
40	KH-4300-4	CROP 5000 GAUGE ASSY	1
41	KH-5040	FAN ASSEMBLY 1060	1
42	P3000-10L	10LT HAND WASH TANK TO SUIT 3000LT	1
43	P5000AB-RAW	TANK 5000LT POLY AIRBLAST RAW	1
44	TFAD1212FM	ADAPTOR 1/2" BSPF X 1/2" BSPM	1
45	TFEL1212MF	ELBOW 1/2" BSPM X 1/2" BSPF	4
46	M20X140BOLT	M20 X 140 HEX HEAD BOLT HT ZP	1
47	M20X60	M20 X 60 SET SCREW HT ZP	2
48	M20FWASHER	M20 FLAT WASHER ZP	2
49	M20HNUT	M20 HALF NUT ZP	2
50	M20NNUT	M20 NYLOC NUT HT ZP	1
51	M16X50	M16 X 50 HEX HEAD SET SCREW HT ZP	8
52	M16X40	M16 X 40 HEX HEAD SET SCREW	26
53	M16FWASHER	M16 FLAT WASHER ZP	70
54	M16NNUT	M16 NYLOC NUT HT ZP	36
55	M12X35	M12 X 35 SET SCREW HT ZP	19
56	M12FWASHER	M12 FLAT WASHER ZP	38
57	M12NNUT	M12 NYLOC NUT HT ZP	19
58	M10X60BOLT	M10 X 60 BOLT HT ZP	4
59	M10X30	M10 X 30 SET SCREW HT ZP	7
60	M10FWASHER	M10 FLAT WASHER ZP	22
61	M10HNUT	M10 HEX NUT HT ZP	4
62	M10NNUT	M10 NYLOC NUT HT ZP	11

Please contact Technical support for further details

SECTION 10

ASSEMBLY DRAWINGS, PARTS & SCHEMATICS

CROPLINER 4000/1060DSV

ITEM NO.	PART NUMBER	DESCRIPTION	QTY.
1	A300130	FILTER BASKET LARGE 254MM DEEP	1
2	A350620	LID RING WITH GASKET	1
3	A3510060	LID/RING KIT 455MM	1
4	A3522120	LID ONLY 255MM CLOSED	1
5	BP-184	JOCKEY STAND LONG PINTO	1
6	BP-543	SAFETY TOWING CHAIN 10 X 960	1
7	G8170015	LID HINGED 180 DEGREE 455MM	1
7	HP-006	SPIGOT PLATE JACK STAND	1
9	HP-202GA	WHEEL/TYRE 400X15.5 NO OFFSET	2
10	HP-205A	AXLE ASSEMBLY LOW CLEARANCE 4000LT	1
	HP-205AB	AXLE ASSEMBLY HIGH CLEARANCE 4000LT	option
11	HP-284B	FAN & TANK BRACKET 4000LT	1
12	HP-286A	BRACKET ECM 3000 QUANTUM MIST	2
13	HP-289	MANIFOLD BRACKET A463CCRO08A	1
14	HP4000ABA	CHASSIS 4000LT AIRBLAST HAYLITE	1
15	HP-400A	DRAWBAR LONG	1
16	HP-405	BRACKET FILTER SUCTION	1
17	HP-434A	BRACKET DAM FILL REAR 4000LT	1
18	HP-702A	STEP, RETRACTABLE 4000LT	1
19	HP-704LA	SIDE RAIL L.H. 4000LT HAYLITE	1
20	HP-704RA	SIDE RAIL RH 4000LT HAYLITE	1
21	HP-710	BUMPER LEAF SHIELD 4000LT	1
22	HP-711A	FRONT TANK SUPPORT 4000LT	1
23	HP-715L	TIE DOWN ROD LH 4000LT	1
24	HP-715R	TIE DOWN ROD RH 4000LT	1
25	KH-5040	FAN ASSEMBLY 1060	1
26	P4000AB-RAW	4000LT TANK POLY AIRBLAST POLY	1
27	50SQWASHER	50MM SQUARE WASHER	12
28	M20X140BOLT	M20 X 140 HEX HEAD BOLT HT ZP	1
29	M20X60	M20 X 60 SET SCREW HT ZP	2
30	M20FWASHER	M20 FLAT WASHER ZP	2
31	M20HNUT	M20 HALF NUT ZP	2
32	M20NNUT	M20 NYLOC NUT HT ZP	1
33	M16X50	M16 X 50 HEX HEAD SET SCREW HT ZP	8
34	M16FWASHER	M16 FLAT WASHER ZP	18
35	M16NNUT	M16 NYLOC NUT HT ZP	10
36	M12X40	M12 X 40 HEX HEAD SET SCREW HT ZP	8
37	M12X35	M12 X 35 SET SCREW HT ZP	14
38	M12X30	M12 X 30 SET SCREW HT ZP	30
39	M12FWASHER	M12 FLAT WASHER ZP	88
40	M12NNUT	M12 NYLOC NUT HT ZP	42
41	M12SWASHER	M12 SPRING WASHER ZP	6
42	M10X25	M10 X 25 SET SCREW HT ZP	6
43	M10FWASHER	M10 FLAT WASHER ZP	12
44	M10NNUT	M10 NYLOC NUT HT ZP	6

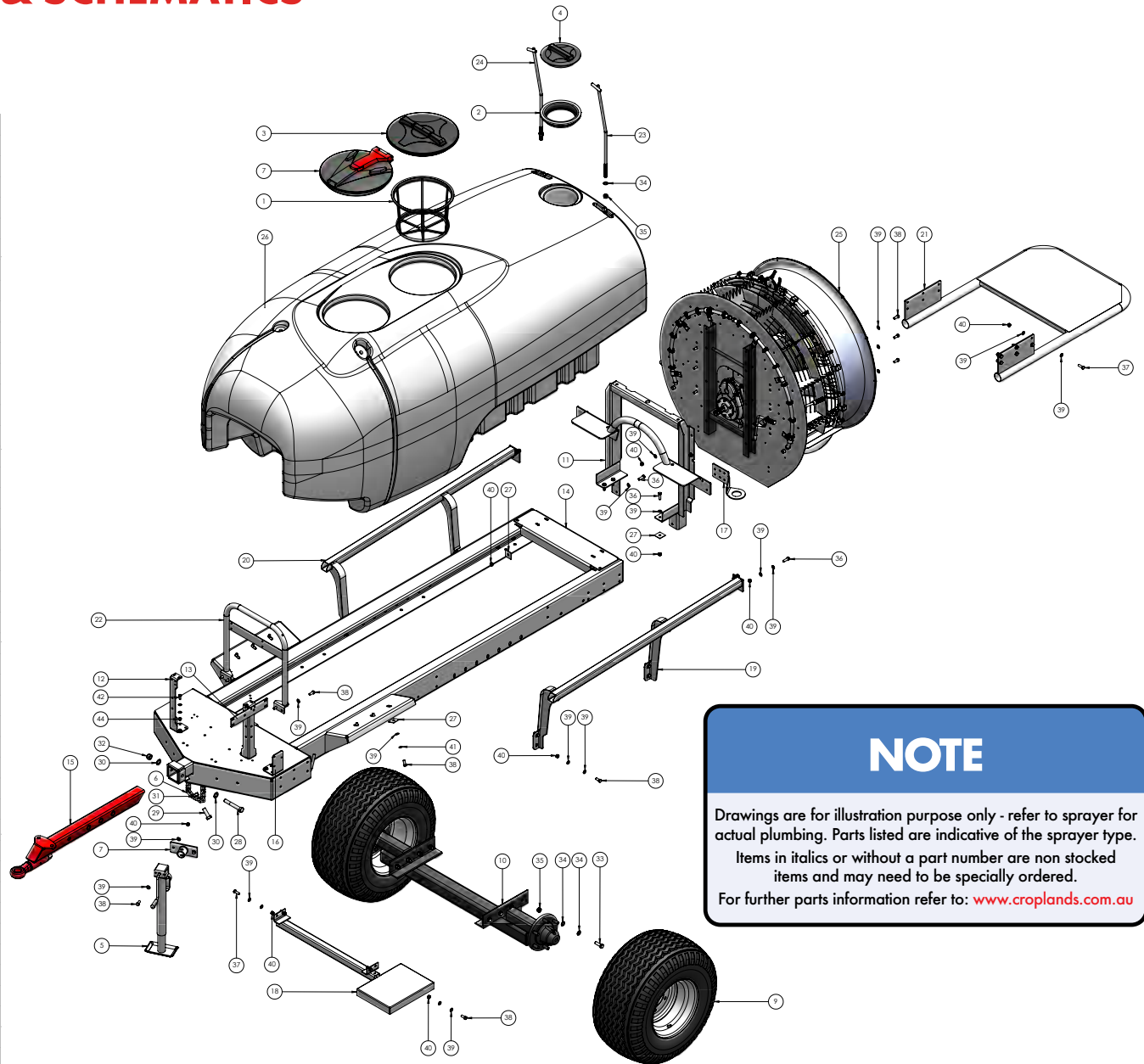

NOTE

Drawings are for illustration purpose only - refer to sprayer for actual plumbing. Parts listed are indicative of the sprayer type.

Items in italics or without a part number are non stocked items and may need to be specially ordered.

For further parts information refer to: www.croplands.com.au

SECTION 10

ASSEMBLY DRAWINGS, PARTS & SCHEMATICS

CROPLINER 4000/920DSV

ITEM NO.	PART NUMBER	DESCRIPTION	QTY.
1	A300130	FILTER BASKET LARGE 254MM DEEP	1
2	A350620	LID RING WITH GASKET	1
3	A3510060	LID/RING KIT 455MM	1
4	A3522120	LID ONLY 255MM CLOSED	1
5	BP-184	JOCKEY STAND LONG PINTO	1
6	BP-543	SAFETY TOWING CHAIN 10 X 960	1
7	HP-006	SPIGOT PLATE JACK STAND	1
8	HP-205A	AXLE ASSEMBLY 4000LT POLY	1
9	HP-284B		1
10	HP-202GA	WHEEL/TYRE 400X15.5 NO OFFSET	2
11	HP-286A	BRACKET ECM 3000LT QUANTUM	2
12	HP-289	MANIFOLD BRACKET A463CCRO08A	1
13	HP4000ABA	CHASSIS 4000LT AIRBLAST HAYLITE	1
14	HP-400A	DRAWBAR LONG	1
15	HP-405	BRACKET FILTER SUCTION	1
16	HP-410	BUMPER C/W LEAF SHIELD 2000LT	1
17	HP-434A	BRACKET DAM FILL REAR 4000LT	1
18	HP-702A	STEP, RETRACTABLE 4000LT	1
19	HP-704LA	SIDE RAIL L.H. 4000LT HAYLITE	1
20	HP-704RA	SIDE RAIL RH 4000LT HAYLITE	1
21	HP-706	BUMPER BRACKET	2
22	HP-711A	FRONT TANK SUPPORT 4000LT	1
23	HP-715L	TIE DOWN ROD L.H. 4000LT	1
24	HP-715R	TIE DOWN ROD R.H. 4000LT	1
25	KH-5035	FAN ASSEMBLY 920VNS S/STEEL	1
26	50SQWASHER	50MM SQUARE WASHER	12
27	M20X140BOLT	M20 X 140 HEX HEAD BOLT HT ZP	1
28	M20X60	M20 X 60 SET SCREW HT ZP	2
29	M20FWASHER	M20 FLAT WASHER ZP	2
30	M20HNUT	M20 HALF NUT ZP	2
31	M20NNUT	M20 NYLOC NUT HT ZP	1
32	M16X50	M16 X 50 HEX HEAD SET SCREW HT ZP	8
33	M16FWASHER	M16 FLAT WASHER ZP	18
34	M16NNUT	M16 NYLOC NUT HT ZP	10
35	M12X40	M12 X 40 HEX HEAD SET SCREW HT ZP	8
36	M12X35	M12 X 35 SET SCREW HT ZP	2
37	M12X30	M12 X 30 SET SCREW HT ZP	37
38	M12FWASHER	M12 FLAT WASHER ZP	72
39	M12NNUT	M12 NYLOC NUT HT ZP	34
40	M12SSHUT	M12 HEX NUT HT S/S	4
41	M12SWASHER	M12 SPRING WASHER ZP	6
42	M10X25	M10 X 25 SET SCREW HT ZP	6
43	M10FWASHER	M10 FLAT WASHER ZP	12
44	M10NNUT	M10 NYLOC NUT HT ZP	6
45	P3000AB-RAW	3000LT TANK POLY AIRBLAST RAW	1
46	G8170015	LID HINGED 180 DEGREE 455MM	1

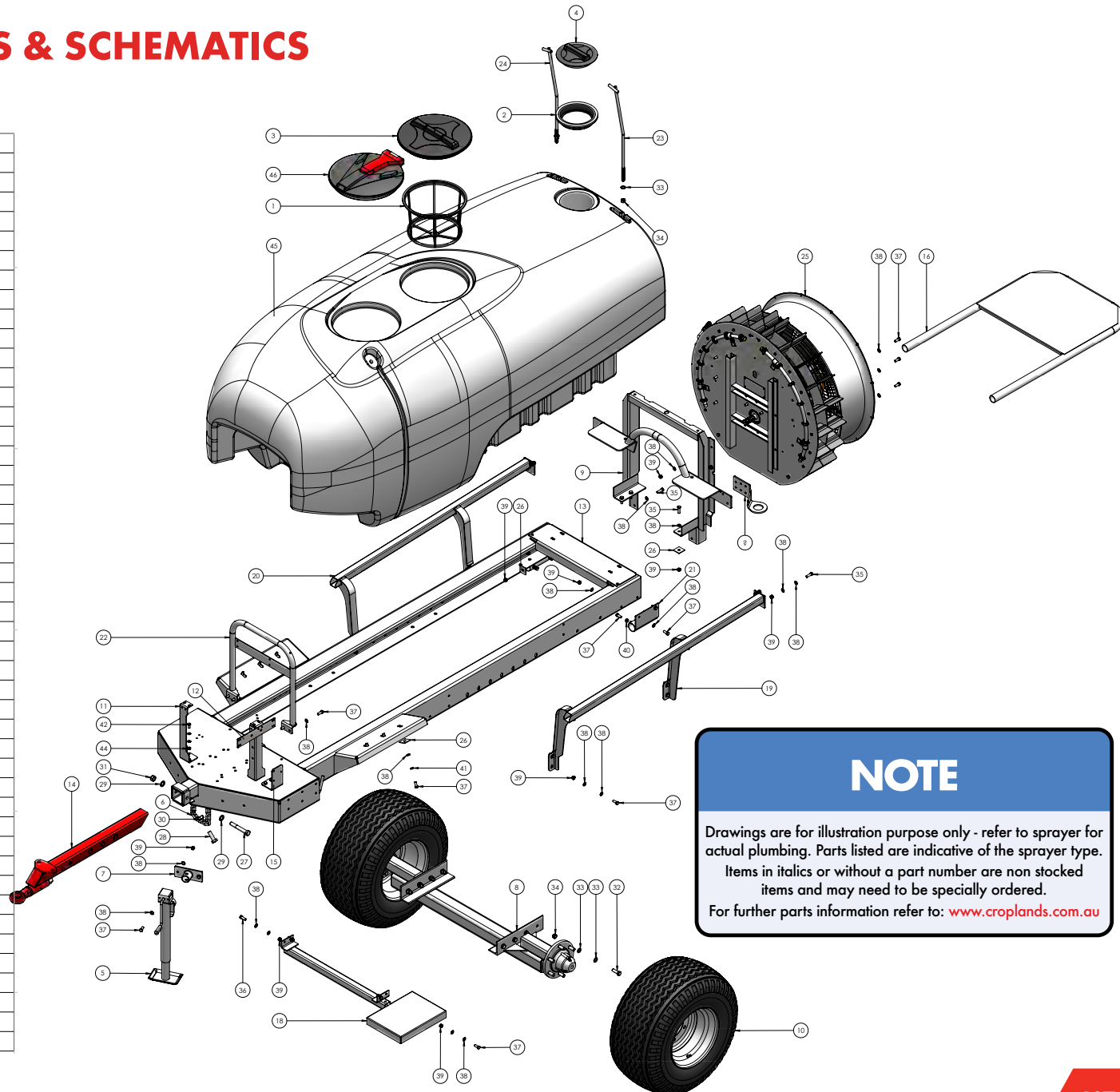

NOTE

Drawings are for illustration purpose only - refer to sprayer for actual plumbing. Parts listed are indicative of the sprayer type. Items in *italics* or without a part number are non stocked items and may need to be specially ordered. For further parts information refer to: www.croplands.com.au

Please contact Technical support for further details

SECTION 10

ASSEMBLY DRAWINGS, PARTS & SCHEMATICS

CROPLINER 3000/920DSV

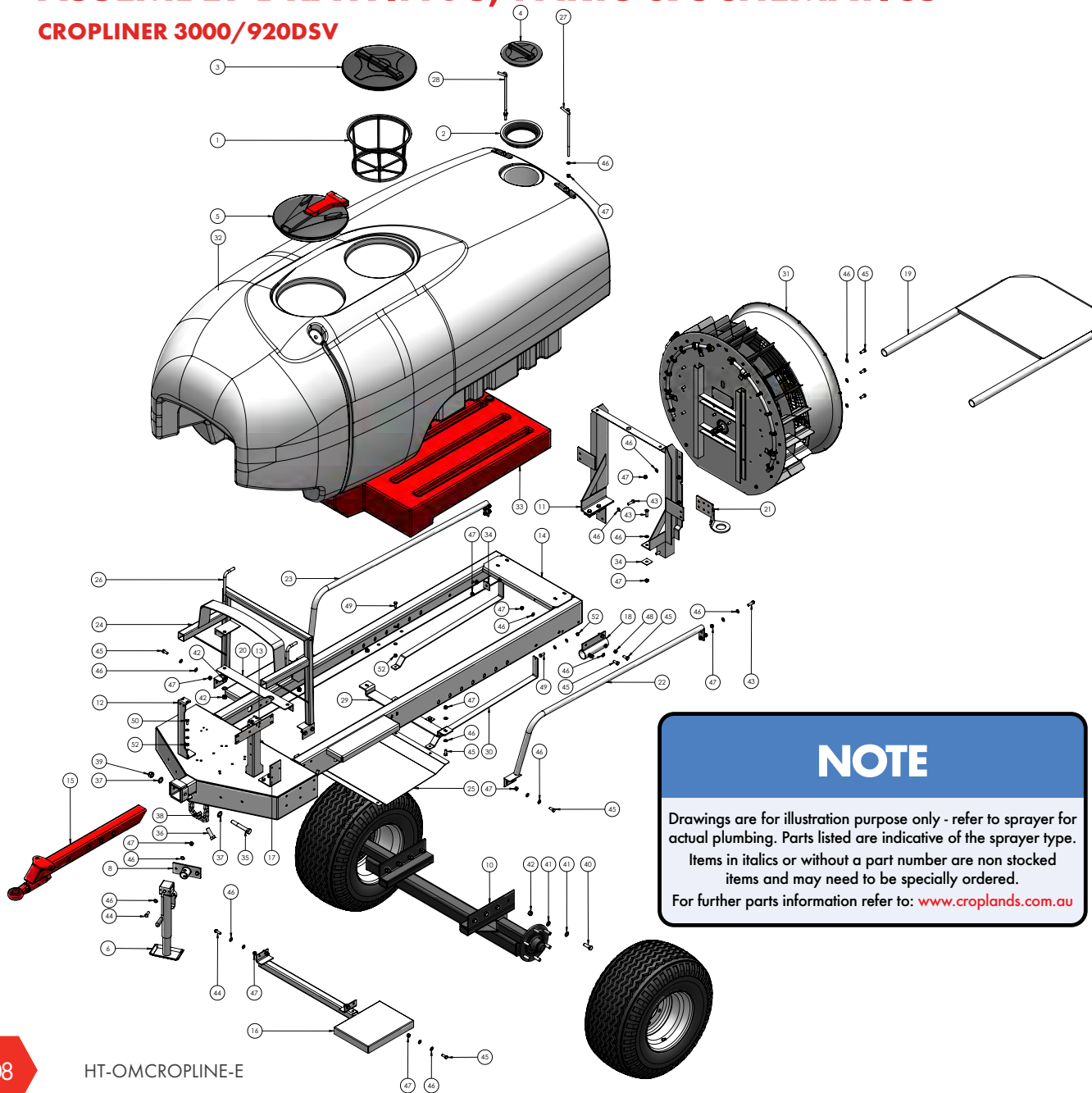

NOTE

Drawings are for illustration purpose only - refer to sprayer for actual plumbing. Parts listed are indicative of the sprayer type. Items in *italics* or without a part number are non stocked items and may need to be specially ordered. For further parts information refer to: www.croplands.com.au

ITEM NO.	PART NUMBER	DESCRIPTION	QTY.
1	A300130	FILTER BASKET LARGE 254MM DEEP	1
2	A350620	LID RING WITH GASKET	1
3	A3510060	LID/RING KIT 455MM	1
4	A3522120	LID ONLY 255MM CLOSED	1
5	G8170015	LID HINGED 180 DEGREE 455MM	1
6	BP-184	JOCKEY STAND LONG PINTO	1
7	BP-543	SAFETY TOWING CHAIN 10 X 960	1
8	HP-006	SPIGOT PLATE JACK STAND	1
9	HP-202GA	WHEEL/TYRE 400X15.5 NO OFFSET	2
10	HP-205B	AXLE ASSEMBLY SOLID 3000LT	1
11	HP-284E	FAN & TANK BRACKET	1
12	HP-286A	BRACKET ECM 3000LT QUANTUM	2
13	HP-289	MANIFOLD BRACKET A463CCRO08A	1
14	HP3000ABA	CHASSIS 3000LT AIRBLAST HAYLITE	1
15	HP-400A	DRAWBAR LONG	1
16	HP-402A	RETRACTABLE STEP 2000LT	1
17	HP-405	BRACKET FILTER SUCTION	1
18	HP-406	BUMPER BRACKET	2
19	HP-410	BUMPER C/W LEAF SHIELD 2000LT	1
20	HP-432A	BRAGLIA VALVE BRACKET 3000LT	1
21	HP-434A	BRACKET DAM FILL REAR 4000LT	1
22	HP-504LA	SIDE RAIL 3000LT LH	1
23	HP-504RA	SIDE RAIL 3000LT RH	1
24	HP-511	FRONT TANK SUPPORT 3000LT	1
25	HP-512	SUMP GUARD 3000LT	1
26	HP-514	FRONT TIE DOWN ROD 3000LT	2
27	HP-515L	REAR LEFT TIE DOWN ROD 3000LT	1
28	HP-515R	REAR RIGHT TIE DOWN ROD 3000LT LT	1
29	HP-520	CROSS RAIL BRACKET FLUSH TANK	1
30	HP-521	SUPPORT STRAP FLUSH TANK	2
31	KH-5035	FAN ASSEMBLY 920VNS S/STEEL	1
32	P3000AB-RAW	3000LT TANK POLY AIRBLAST RAW	1
33	P3000AB-110RAW	FLUSH TANK 110LT 3000LT	1
34	50SQWASHER	50MM SQUARE WASHER	6
35	M20X140BOLT	M20 X 140 HEX HEAD BOLT HT ZP	1
36	M20X60	M20 X 60 SET SCREW HT ZP	2
37	M20FWASHER	M20 FLAT WASHER ZP	2
38	M20HNNUT	M20 HALF NUT ZP	2
39	M20NNUIT	M20 NYLOC NUT HT ZP	1
40	M16X50	M16 X 50 HEX HEAD SET SCREW HT ZP	8
41	M16FWASHER	M16 FLAT WASHER ZP	18
42	M16NNUIT	M16 NYLOC NUT HT ZP	12
43	M12X40	M12 X 40 HEX HEAD SET SCREW HT ZP	8
44	M12X35	M12 X 35 SET SCREW HT ZP	4
45	M12X30	M12 X 30 SET SCREW HT ZP	30
46	M12FWASHER	M12 FLAT WASHER ZP	72
47	M12NNUIT	M12 NYLOC NUT HT ZP	40
48	M12SSHNUIT	M12 HEX NUT HT S/S	4
49	M10X30	M10 X 30 SET SCREW HT ZP	4
50	M10X25	M10 X 25 SET SCREW HT ZP	6
51	M10FWASHER	M10 FLAT WASHER ZP	20
52	M10NNUIT	M10 NYLOC NUT HT ZP	10

Please contact Technical support for further details

SECTION 10

ASSEMBLY DRAWINGS, PARTS & SCHEMATICS

CROPLINER 2000/920DSV

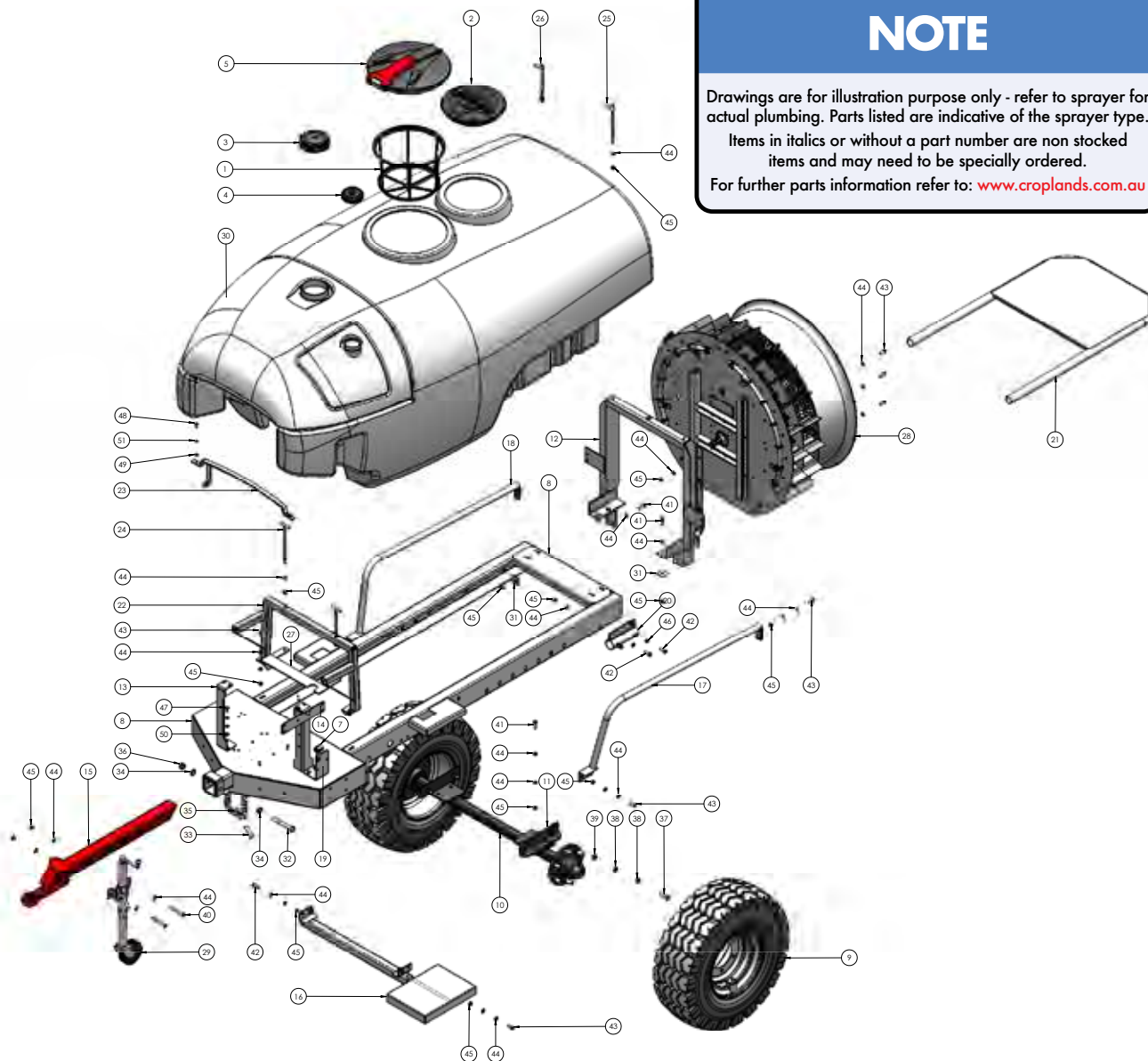

NOTE

Drawings are for illustration purpose only - refer to sprayer for actual plumbing. Parts listed are indicative of the sprayer type. Items in *italics* or without a part number are non stocked items and may need to be specially ordered. For further parts information refer to: www.croplands.com.au

ITEM NO.	PART NUMBER	DESCRIPTION	QTY.
1	A300130	FILTER BASKET LARGE 254MM DEEP	1
2	A3510040	LID/RING KIT 355MM	1
3	A354010	LID 6" C/W SPRING BREATHER & OUTLET	1
4	A354030	LID 4" C/W BREATHER & SEAL	1
5	A356060	LID HINGED 180 DEGREE 455MM	1
6	BP-543	SAFETY TOWING CHAIN 10 X 960	1
7	FM-FDSOCKET	SOCKET FOAM MARKER DROPPER	1
8	HP2000ABA	CHASSIS AIRBLAST 2000LT HAYLITE	1
9	HP-200	TYRE & WHEEL AWT 11.5/80-15.3	2
10	HP-205DA	AXLE ASSEMBLY 50MM X 1200 HUB TO HUB	1
11	HP-205D-1	BOLTING ANGLE	2
12	HP-284	FAN & TANK BRACKET 2000CROPLINER	1
13	HP-286A	BRACKET ECM 3000LT QUANTUM	2
14	HP-289	MANIFOLD BRACKET A463CCRO08A	1
15	HP-400A	DRAWBAR LONG	1
16	HP-402A	RETRACTABLE STEP 2000LT	1
17	HP-404L	SIDE RAIL LH 2000LT	1
18	HP-404R	SIDE RAIL RH 2000LT	1
19	HP-405	BRACKET FILTER SUCTION	1
20	HP-406	BUMPER BRACKET	2
21	HP-410	BUMPER C/W LEAF SHIELD 2000LT	1
22	HP-411	FRONT TANK SUPPORT 2000LT	1
23	HP-413	CROSS BAR	1
24	HP-414	FRONT TIE DOWN ROD 2000LT	2
25	HP-415L	REAR LEFT TIE DOWN ROD 2000LT	1
26	HP-415R	REAR RIGHT TIE DOWN ROD 2000LT	1
27	HP-432	BRAGLIA VALVE BRACKET	1
28	KH-5035	FAN ASSEMBLY 920VNS S/STEEL	1
29	MUJOCKEY	JOCKEY WHEEL	1
30	P2000AAB-RAW	TANK 2000LT POLY RAW AIRBLAST	1
31	S0SQWASHER	50MM SQUARE WASHER	6
32	M20X140BOLT	M20 X 140 HEX HEAD BOLT HT ZP	1
33	M20X60	M20 X 60 SET SCREW HT ZP	2
34	M20FWASHER	M20 FLAT WASHER ZP	2
35	M20HNUIT	M20 HALF NUT ZP	2
36	M20NNUT	M20 NYLOC NUT HT ZP	1
37	M16X50	M16 X 50 HEX HEAD SET SCREW HT ZP	4
38	M16FWASHER	M16 FLAT WASHER ZP	8
39	M16NNUT	M16 NYLOC NUT HT ZP	4
40	M12X100BOLT	M12 X 100 HEX HEAD BOLT HT ZP	2
41	M12X40	M12 X 40 HEX HEAD SET SCREW HT ZP	10
42	M12X35	M12 X 35 SET SCREW HT ZP	9
43	M12X30	M12 X 30 SET SCREW HT ZP	18
44	M12FWASHER	M12 FLAT WASHER ZP	70
45	M12NNUT	M12 NYLOC NUT HT ZP	40
46	M12SSHNUIT	M12 HEX NUT HT S/S	4
47	M10X25	M10 X 25 SET SCREW HT ZP	6
48	M10X20	M10 X 20 SET SCREW HT ZP	2
49	M10FWASHER	M10 FLAT WASHER ZP	14
50	M10NNUT	M10 NYLOC NUT HT ZP	6
51	M10SWASHER	M10 SPRING WASHER ZP	2

Please contact Technical support for further details

SECTION 10

ASSEMBLY DRAWINGS, PARTS & SCHEMATICS

CROPLINER 1500/920DSV

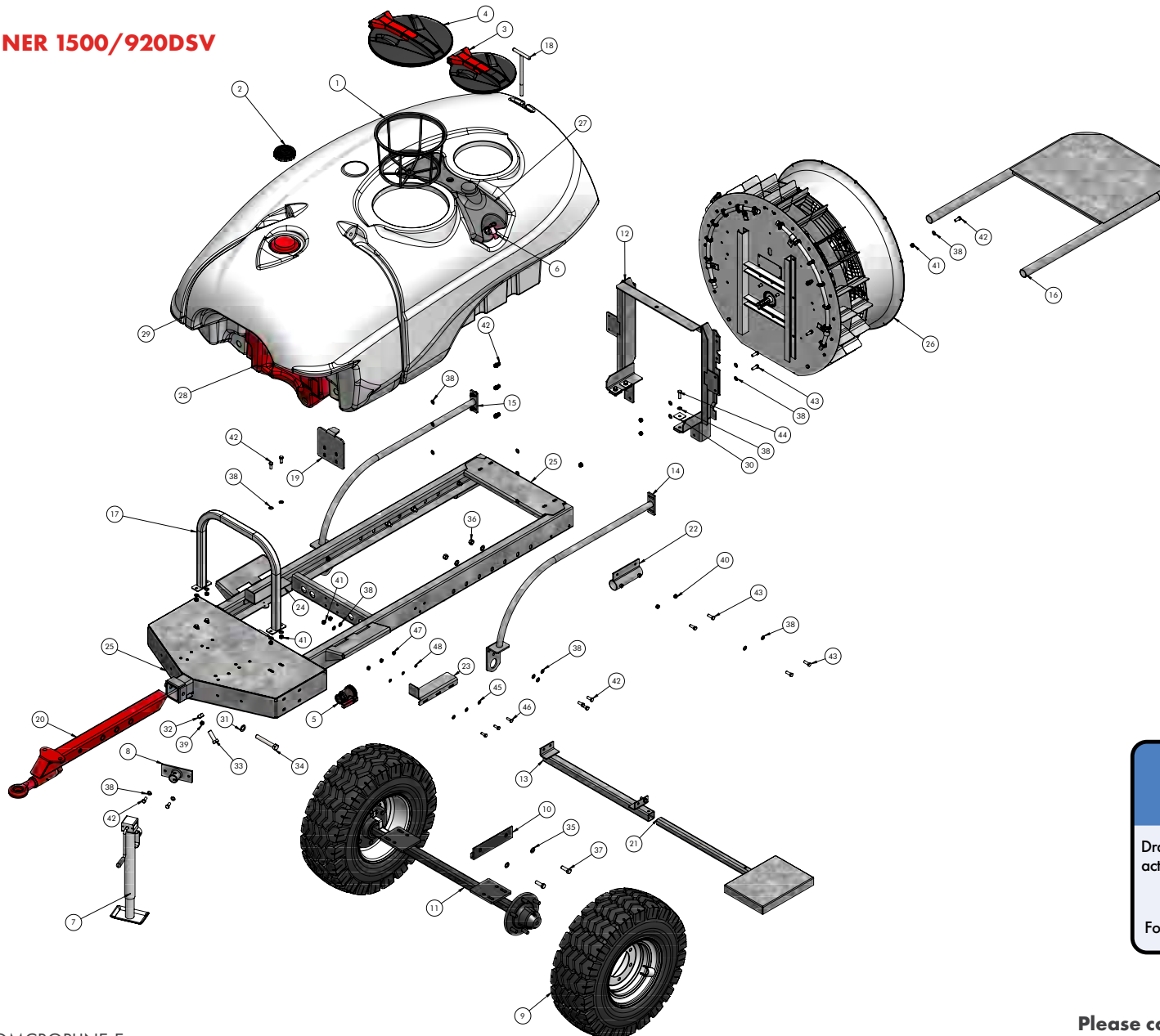

ITEM NO.	PART NUMBER	DESCRIPTION	QTY.
1	A300130	FILTER BASKET LARGE 254MM DEEP	1
2	A354030	LID 4" C/W BREATHER & SEAL	1
3	A356040	LID HINGED 355MM 180DEG	1
4	A356060	LID HINGE 455MM 180DEG	1
5	A454135	VALVE BALL POLY 1 1/4" 2 WAY	1
6	A553018	TAP HANDWASH 17.5MM TAIL	1
7	BP-184	JOCKEY STAND LONG PINTO	1
8	HP-006	SPIGOT PLATE JACK STAND	1
9	HP-200	TYRE & WHEEL AWT 11.5/80-15.3	2
10	HP-205D-1	BOLTING ANGLE	2
11	HP-205DA	AXLE ASSEMBLY 50X50X1200 FL/FL	1
12	HP-284AB	FAN & TANK BRACKET 1500LT	1
13	HP-302-1	HOUSING 1500LT	1
14	HP-304BL	SIDE RAIL 1500LT L.H. HAYLITE	1
15	HP-304BR	SIDE RAIL 1500LT L.H. HAYLITE	1
16	HP-310	BUMPER C/W LEAF SHIELD 1500LT	1
17	HP-311B-001	FRONT TANK SUPPORT	1
18	HP-315A	REAR TIE DOWN 1500LT	1
19	HP-317	MAIN TANK TIE DOWN	1
20	HP-400A	DRAWBAR LONG	1
21	HP-402A-2	STEP	1
22	HP-406	BUMPER BRACKET	2
23	HP-1500B-1L	FLUSH TANK SUPPORT LEFT	1
24	HP-1500B-1R	FLUSH TANK SUPPORT RIGHT	1
25	HP1500B-001LC	CHASSIS 1500LT SERIES 2	1
26	KH-503S	FAN ASSY 920DSV SSTEEL	1
27	P1500AC-15RAW	HAND WASH TANK 1500H	1
28	P1500AC-120RAW	1500LT FLUSH TANK LOS ANGELES	1
29	P1500AC-RAW	TANK 1500L POLY VP	1
30	50SQWASHER	50MM SQUARE WASHER	10
31	M20FWASHER	M20 FLAT WASHER ZP	2
32	M20HNUT	M20 HALF NUT ZP	3
33	M20X60	M20 X 60 SET SCREW HT ZP	2
34	M20X140	M20 X 140 BOLT	1
35	M16FWASHER	M16 FLAT WASHER ZP	8
36	M16HNUT	M16 HEX NUT HT ZP	4
37	M16X50	M16 X 50 HEX HEAD SET SCREW HT ZP	4
38	M12FWASHER	M12 FLAT WASHER ZP	66
39	M12HNUT	M12 HEX NUT HT ZP	2
40	M12SSHNUIT	M12 HEX NUT HT S/S	11
41	M12NNUT	M12 NYLOC NUT HT ZP	31
42	M12X30	M12 X 30 SET SCREW HT ZP	22
43	M12X25	M12 X 25 SET SCREW HT ZP	12
44	M12X40	M12 X 40 HEX HEAD SET SCREW HT ZP	6
45	M10FWASHER	M10 FLAT WASHER ZP	6
46	M10X30	M10 X 30 SET SCREW HT ZP	6
47	M10NNUT	M10 NYLOC NUT HT ZP	6
48	M8FWASHER	M8 FLAT WASHER ZP	7

NOTE

Drawings are for illustration purpose only - refer to sprayer for actual plumbing. Parts listed are indicative of the sprayer type.

Items in *italics* or without a part number are non stocked items and may need to be specially ordered.

For further parts information refer to: www.croplands.com.au

Please contact Technical support for further details

SECTION 10

ASSEMBLY DRAWINGS, PARTS & SCHEMATICS

CROPLINER 5000 PLUMBING SYSTEM

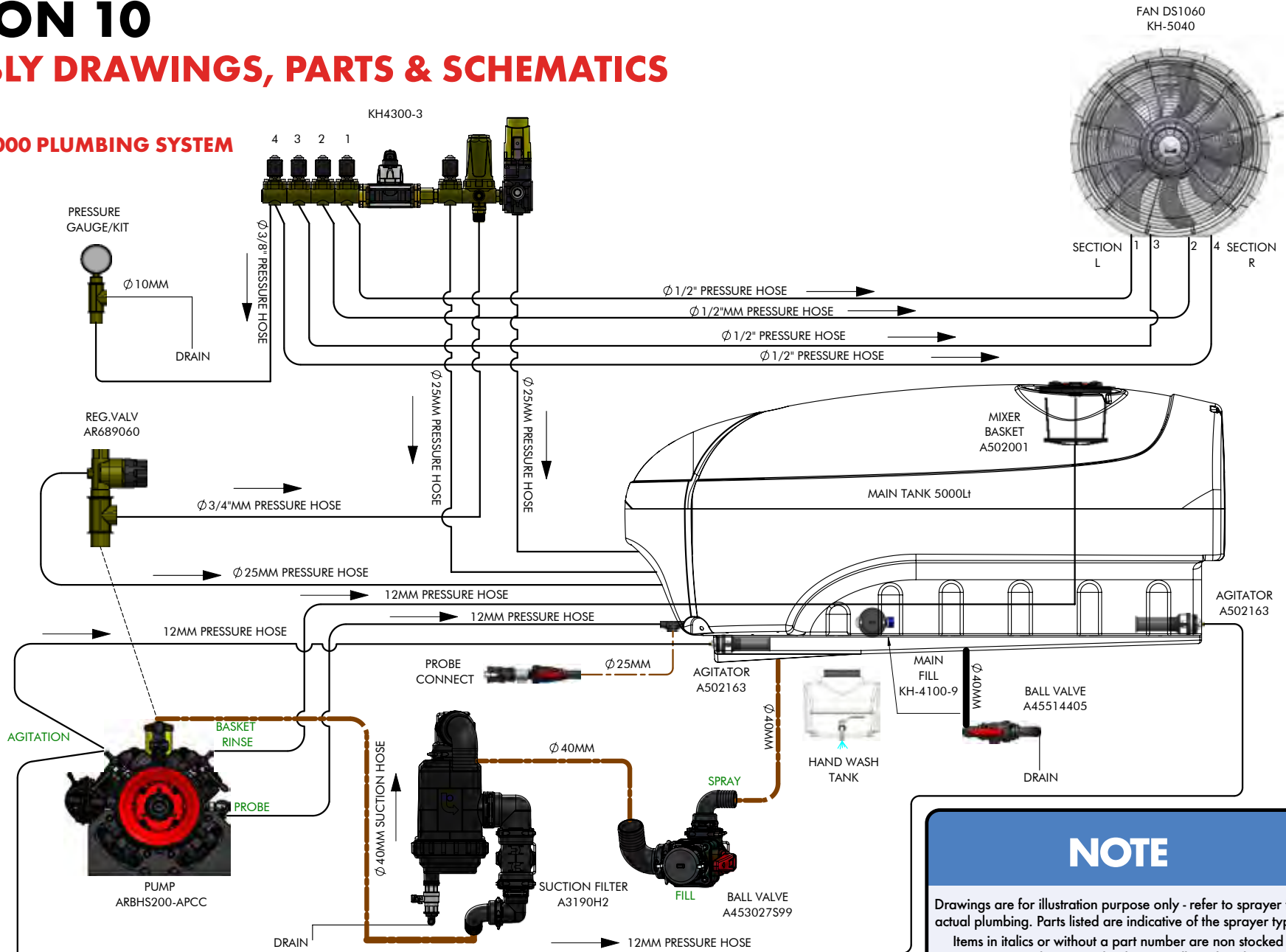

Please contact Technical support for further details

SECTION 10

ASSEMBLY DRAWINGS, PARTS & SCHEMATICS

CROPLINER 4000 PLUMBING SYSTEM

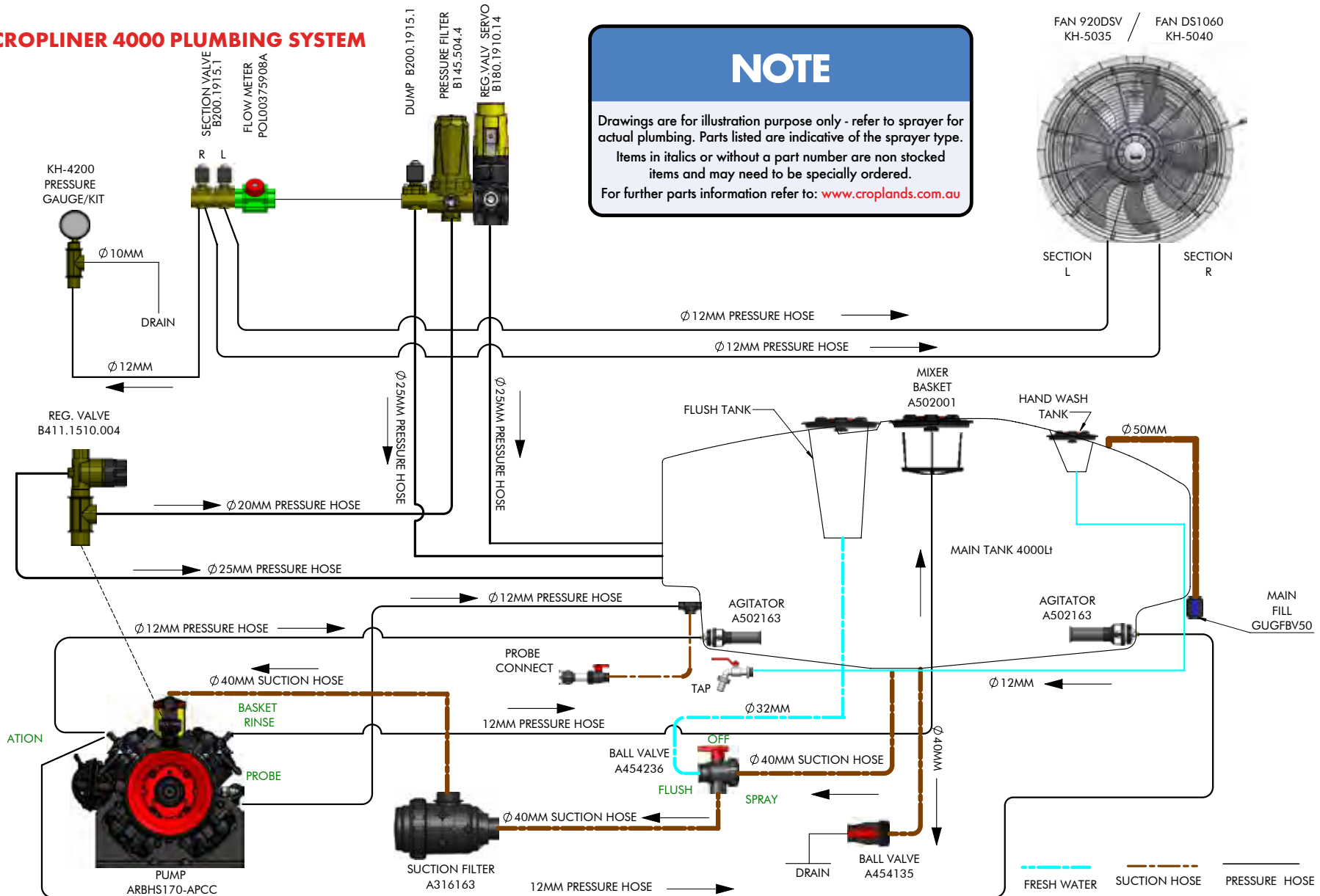

Please contact Technical support for further details

SECTION 10

ASSEMBLY DRAWINGS, PARTS & SCHEMATICS

CROPLINER 3000 PLUMBING SYSTEM

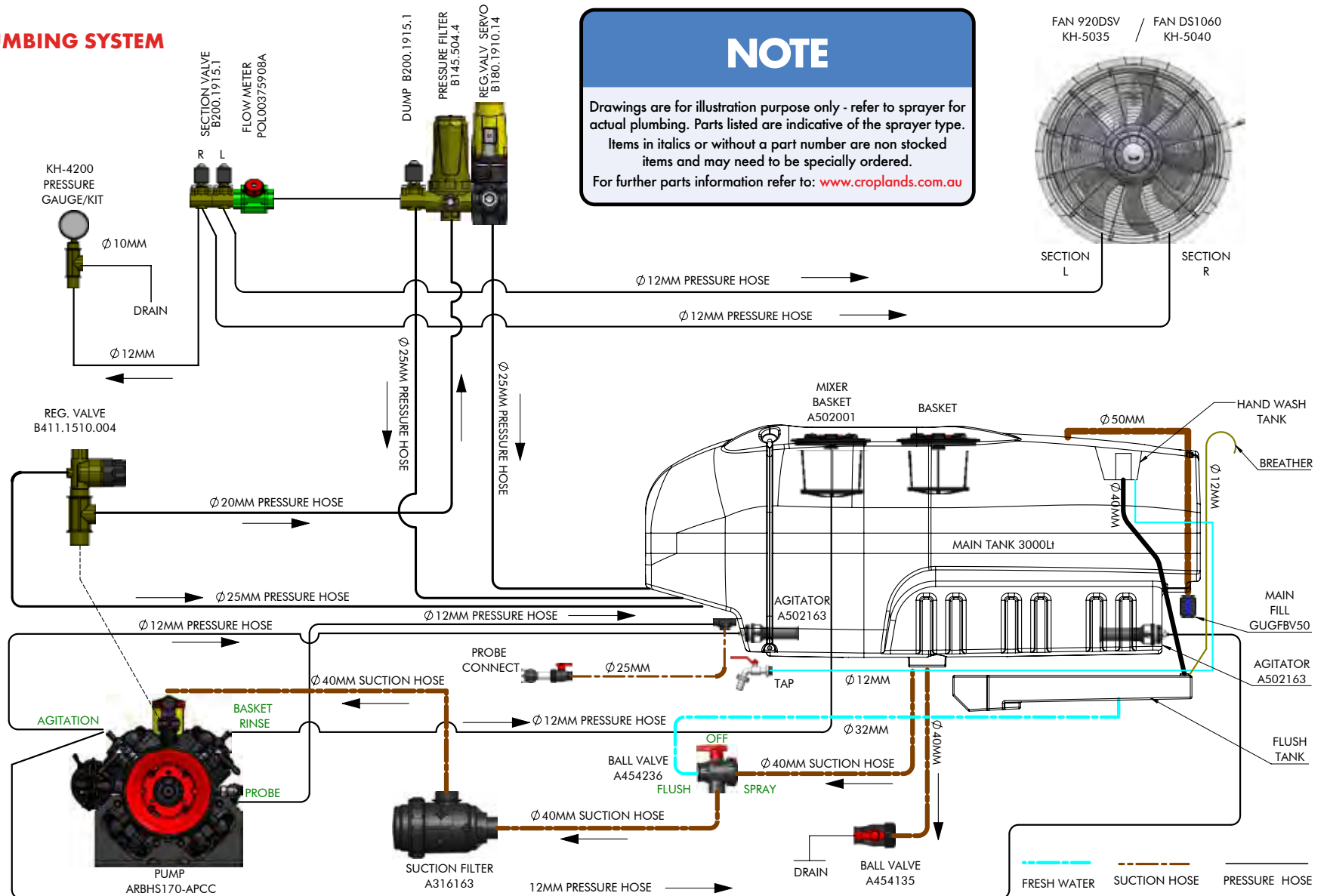

NOTE

Drawings are for illustration purpose only - refer to sprayer for actual plumbing. Parts listed are indicative of the sprayer type. Items in *italics* or without a part number are non stocked items and may need to be specially ordered. For further parts information refer to: www.croplands.com.au

FAN 920DSV / KH-5035 / FAN DS1060 / KH-5040

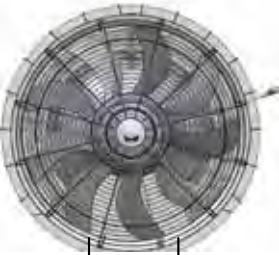

Please contact Technical support for further details

SECTION 10

ASSEMBLY DRAWINGS, PARTS & SCHEMATICS

CROPLINER 2000 PLUMBING SYSTEM

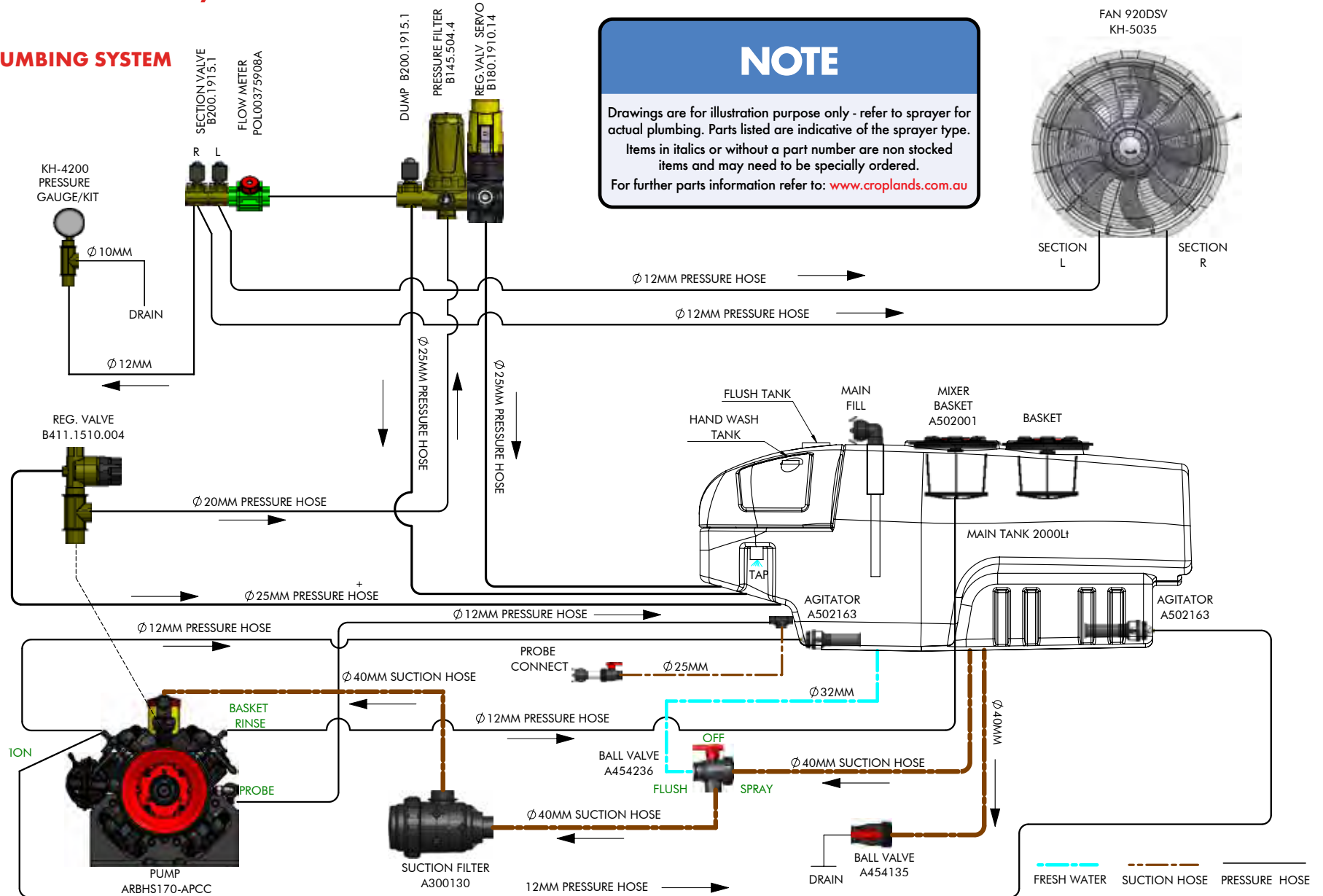

Please contact Technical support for further details

SECTION 10

ASSEMBLY DRAWINGS, PARTS & SCHEMATICS

CROPLINER 1500 PLUMBING SYSTEM

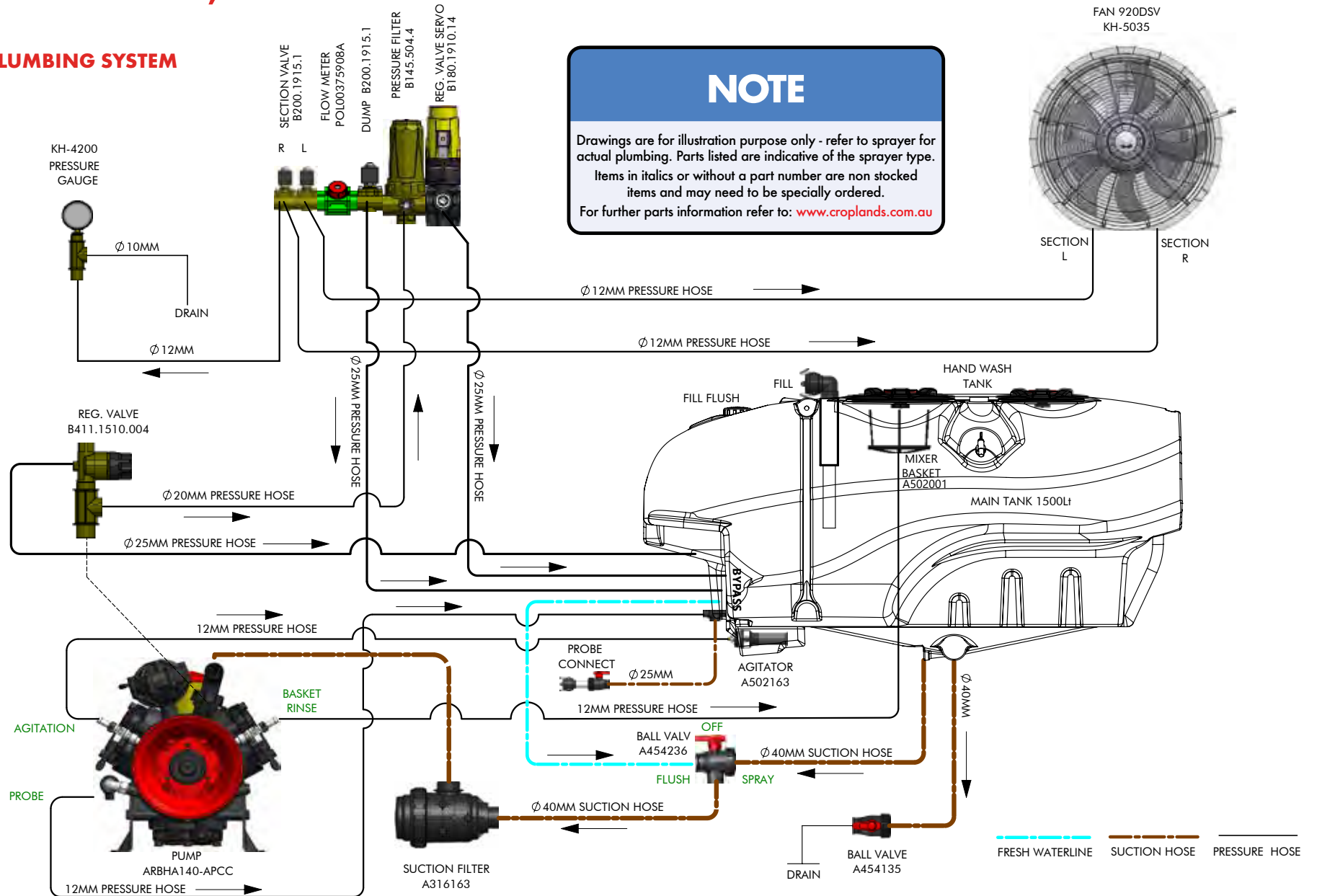

Please contact Technical support for further details

SECTION 10

ASSEMBLY DRAWINGS, PARTS & SCHEMATICS

CROPLINER ELECTRICAL / CONTROLLER - HV4000

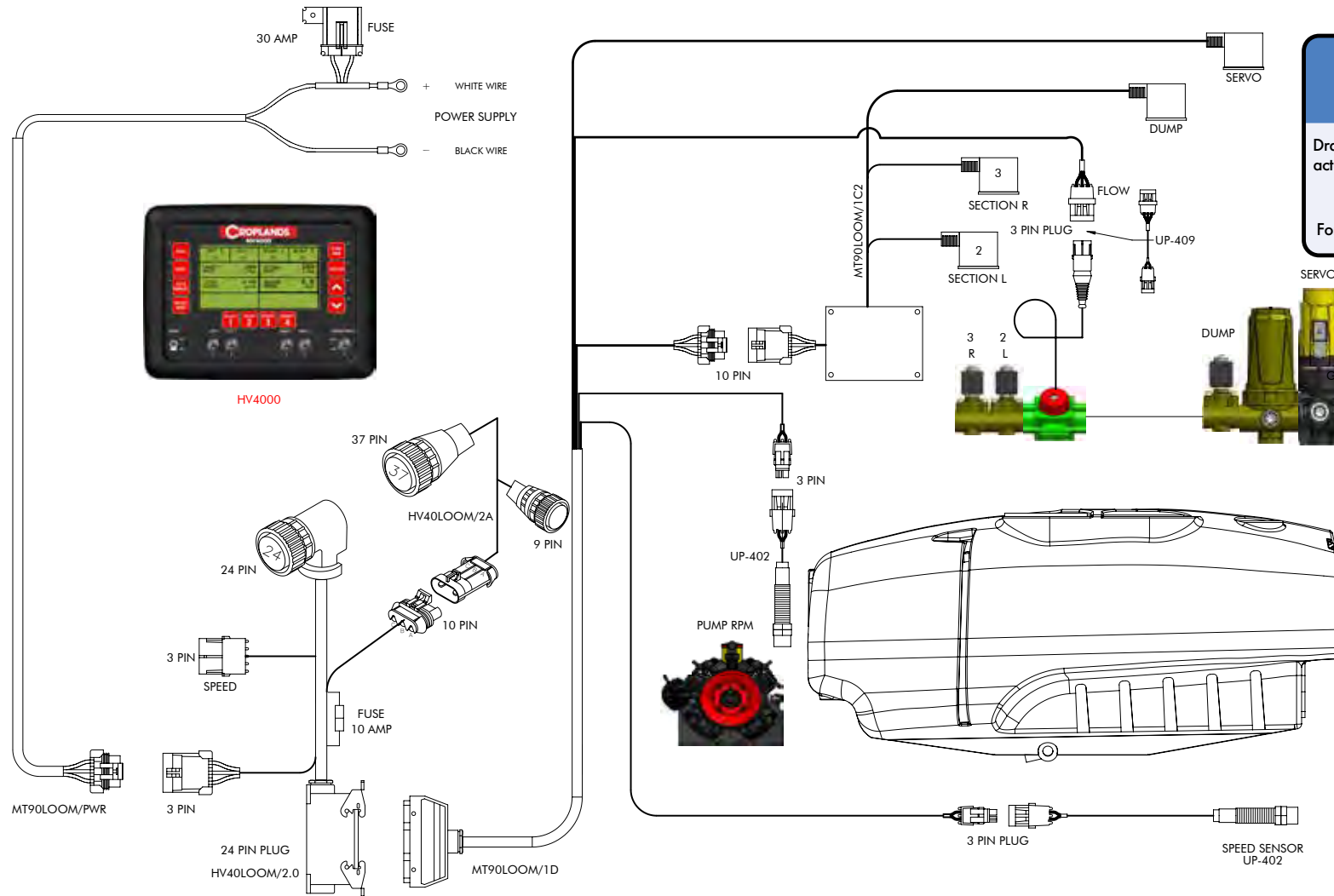

NOTE

Drawings are for illustration purpose only - refer to sprayer for actual plumbing. Parts listed are indicative of the sprayer type. Items in italics or without a part number are non stocked items and may need to be specially ordered. For further parts information refer to: www.croplands.com.au

SECTION 10

ASSEMBLY DRAWINGS, PARTS & SCHEMATICS

CROPLINER ELECTRICAL / CONTROLLER - HV2400

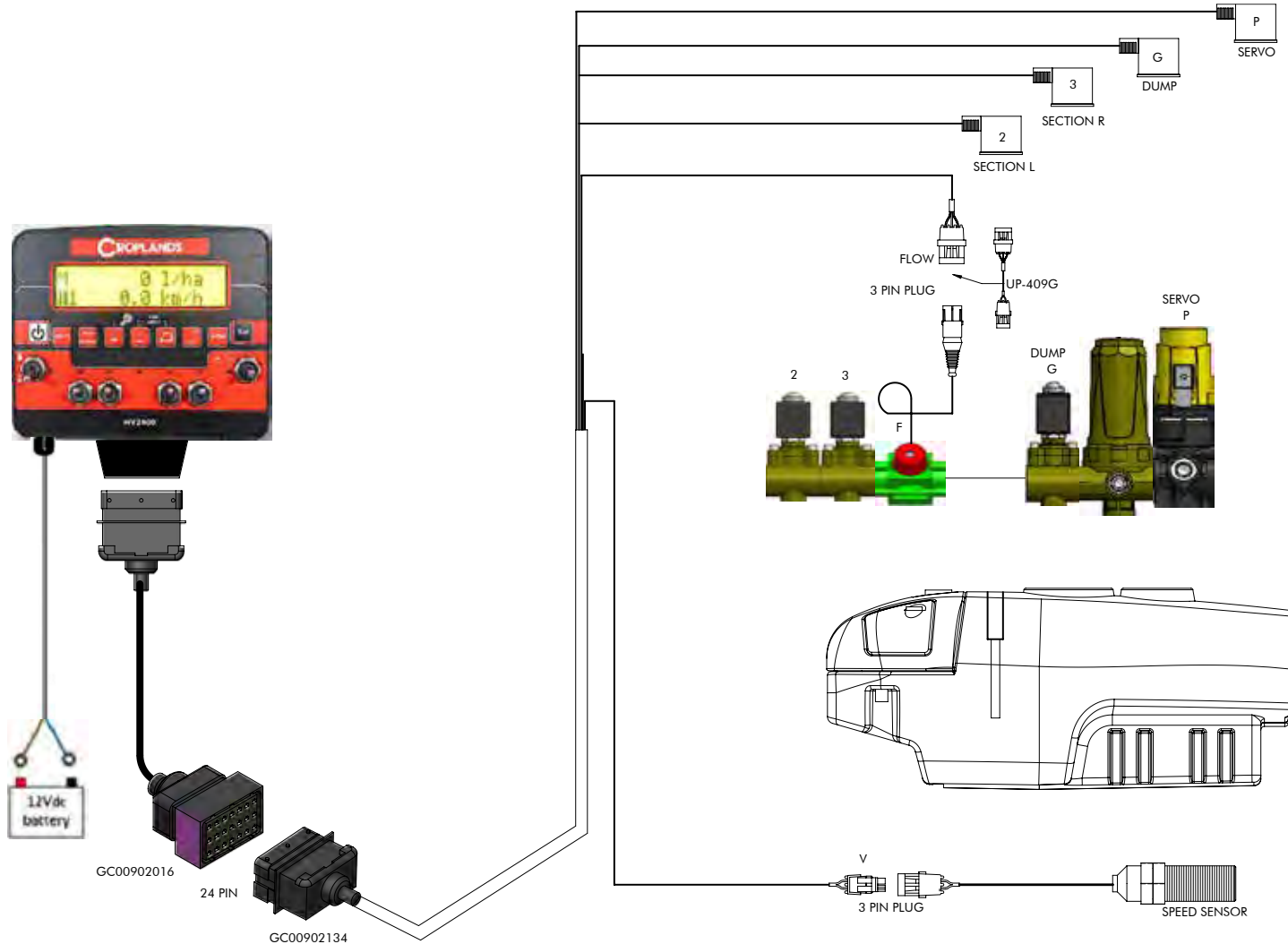

NOTE

Drawings are for illustration purpose only - refer to sprayer for actual plumbing. Parts listed are indicative of the sprayer type.

Items in *italics* or without a part number are non stocked items and may need to be specially ordered.

For further parts information refer to: www.croplands.com.au

Please contact Technical support for further details

SECTION 10

ASSEMBLY DRAWINGS, PARTS & SCHEMATICS

CROPLINER ELECTRICAL / CONTROLLER - BRAVO 180S

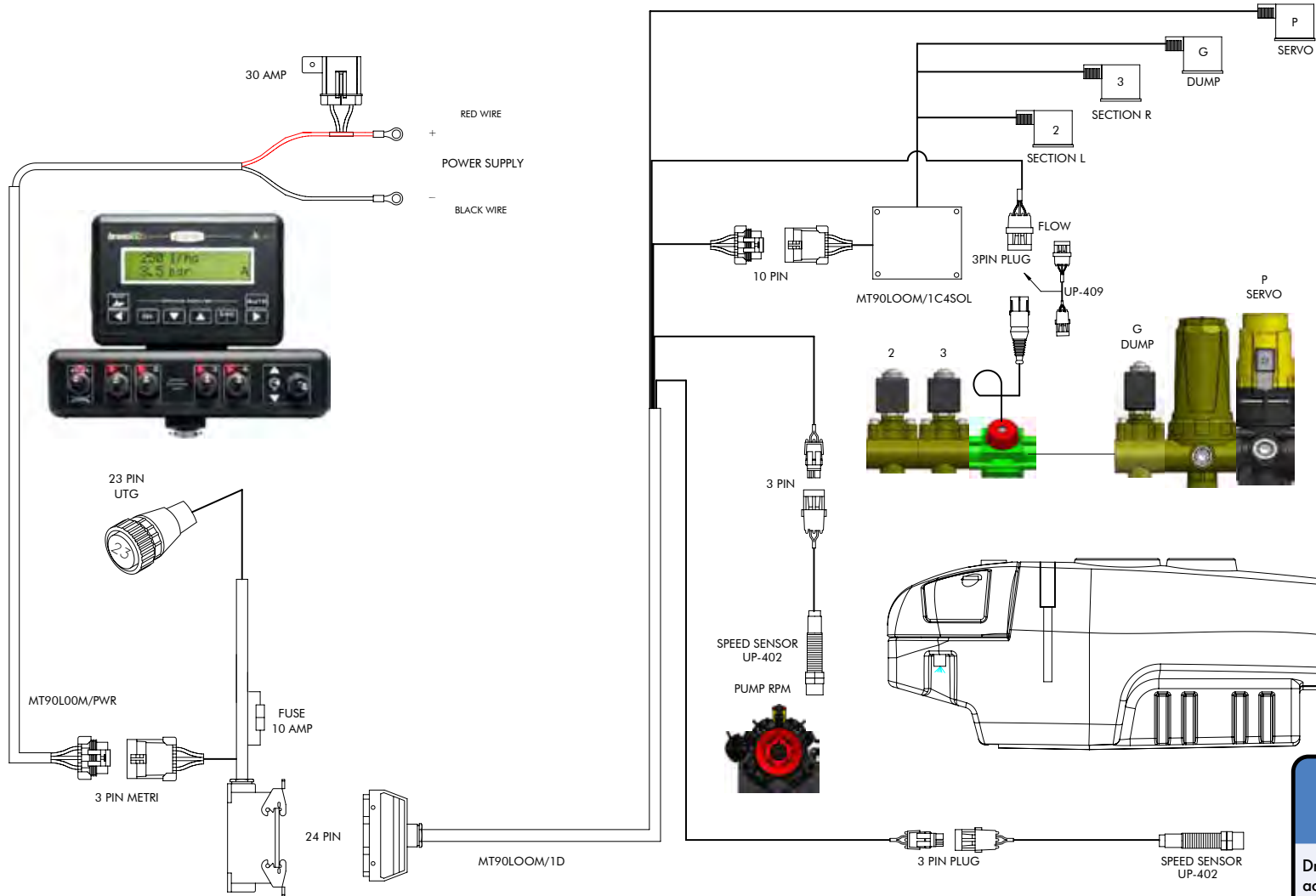

NOTE

Drawings are for illustration purpose only - refer to sprayer for actual plumbing. Parts listed are indicative of the sprayer type. Items in *italics* or without a part number are non stocked items and may need to be specially ordered. For further parts information refer to: www.croplands.com.au

Please contact Technical support for further details

SECTION 10

ASSEMBLY DRAWINGS, PARTS & SCHEMATICS

CROPLINER ELECTRICAL / CONTROLLER - BRAGLIA

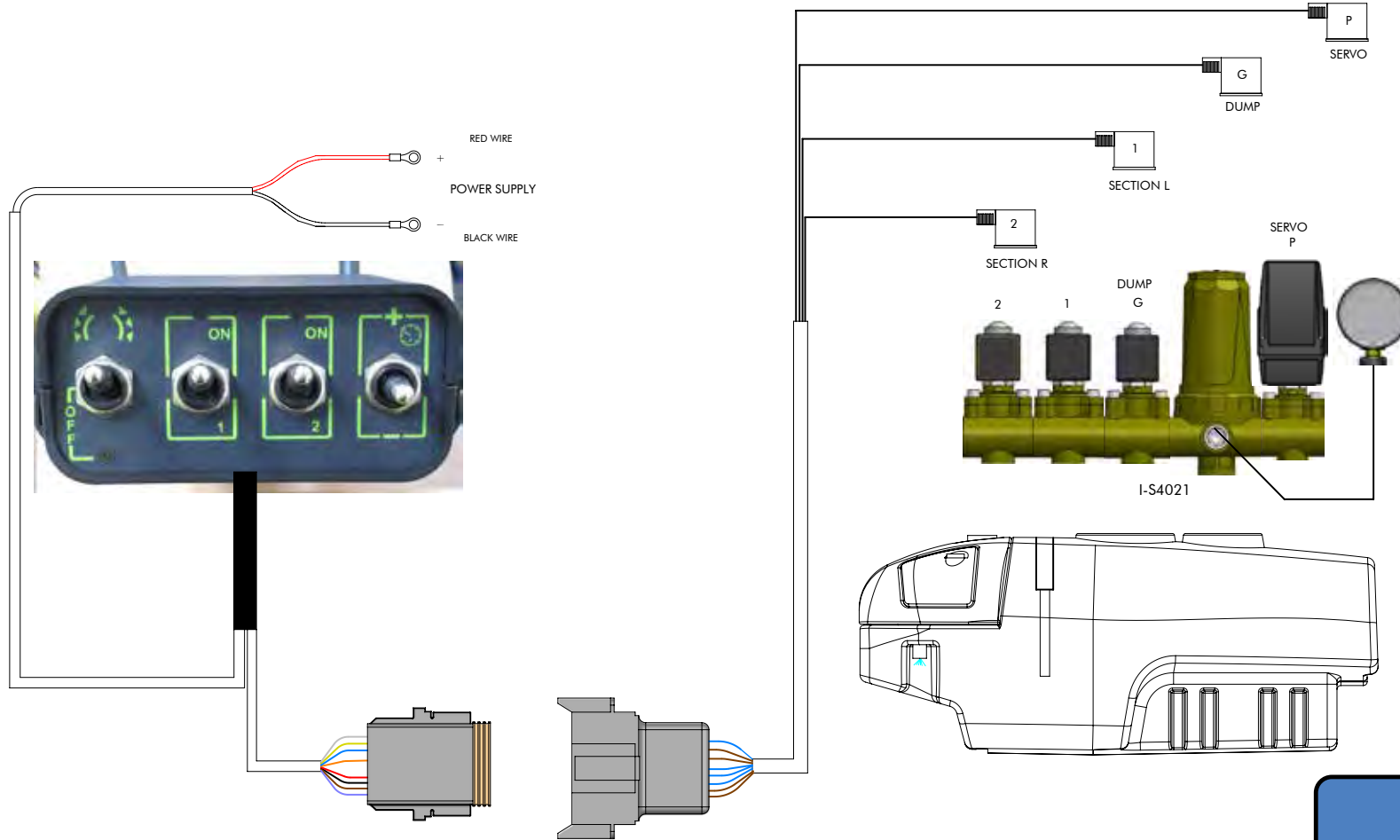

NOTE







Drawings are for illustration purpose only - refer to sprayer for actual plumbing. Parts listed are indicative of the sprayer type. Items in *italics* or without a part number are non stocked items and may need to be specially ordered. For further parts information refer to: www.croplands.com.au

Please contact Technical support for further details

SECTION 10

ASSEMBLY DRAWINGS, PARTS & SCHEMATICS

PTO SHAFT OPTIONS

MODEL	PTO SHAFT, TRACTOR TO PUMP		PUMP	THROUGH SHAFT, PUMP TO FAN	FAN SIZE
CROPLINER 1500XL	SH6AG-1200 / SHCV		AR 140 BHA	SHABTT1520	FIENI 920 DSV
CROPLINER 2000XL	SH6AG-1200 / SHCV		AR 170 BHS / AR 200 BHS	SHABTT1520	FIENI 920 DSV
CROPLINER 3000XL	SH6AG-1200 / SHCV		AR 170 BHS / AR 200 BHS	SHABTT2000	FIENI 920 DSV
CROPLINER 3000XL	SH6AG-1200 / SHCV60		AR 170 BHS / AR 200 BHS	SHABTT4000	FIENI 1060 DSV
CROPLINER 4000XL	SH6AG-1200 / SHCV		AR 170 BHS / AR 200 BHS	SHABTT4000	FIENI 920 DSV
CROPLINER 4000XL	SH6AG-1200 / SHCV60		AR 170 BHS / AR 200 BHS	SHABTT4000	FIENI 1060 DSV
CROPLINER 5000XV	SH6AG-1200 / SHCV60		AR 200 BHS / IDS-260	SHABTT5000	FIENI 1060 DSV



NOTE

Drawings are for illustration purpose only - refer to sprayer for actual plumbing. Parts listed are indicative of the sprayer type.

Items in italics or without a part number are non stocked items and may need to be specially ordered.

For further parts information refer to: www.croplands.com.au

SECTION 10

ASSEMBLY DRAWINGS, PARTS & SCHEMATICS

MISCELLANEOUS

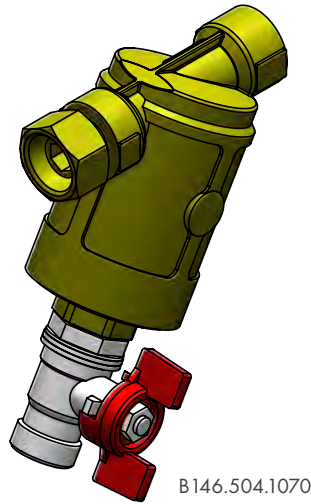

B146.504.1070

IN-LINE PRESSURE FILTER

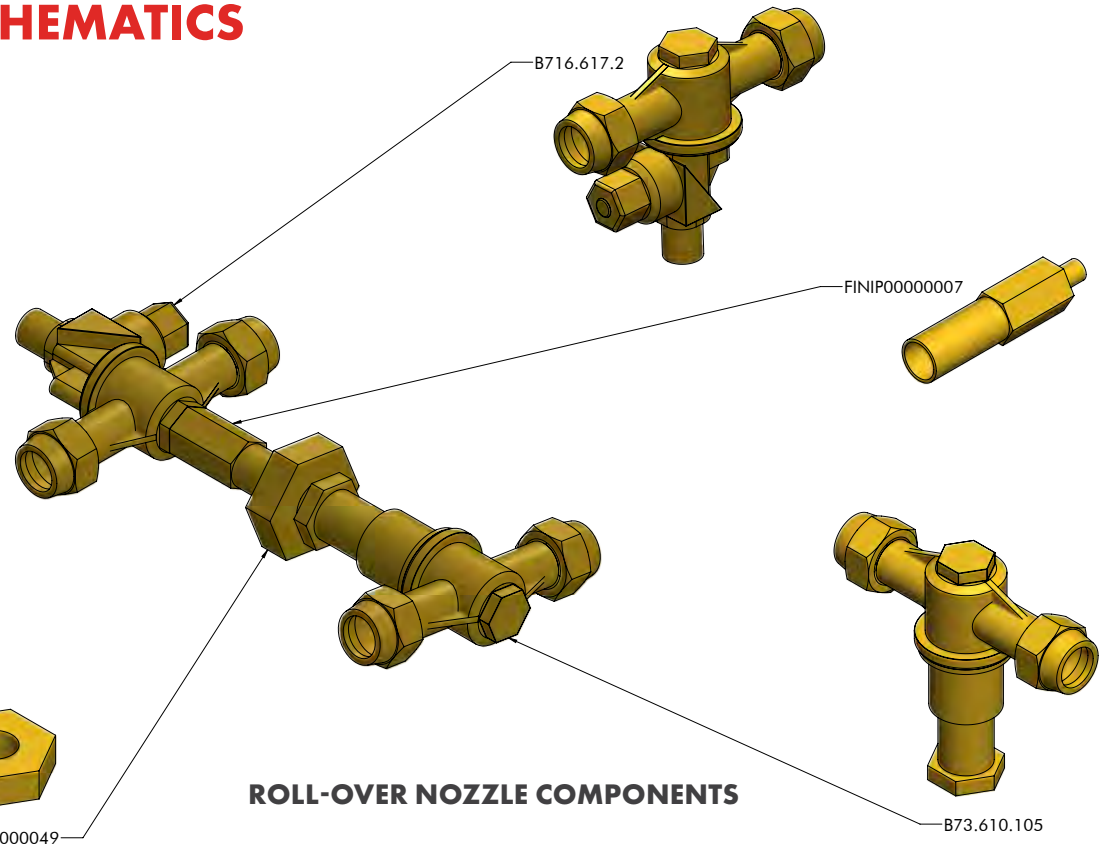

ROLL-OVER NOZZLE COMPONENTS



HT-PROBE

NOTE

Drawings are for illustration purpose only - refer to sprayer for actual plumbing. Parts listed are indicative of the sprayer type.

Items in *italics* or without a part number are non stocked items and may need to be specially ordered.

For further parts information refer to: www.croplands.com.au

Please contact Technical support for further details

SECTION 11

INDEX

- Access platform** 6, 23
- Agitation** 14, 35, 36, 51, 53, 54, 63, 64, 67, 68, 101, 112-116
- Albuz ATR chart** 57, 75, 76, 77, 82
- AR Pump** 14, 34, 50, 58, 94, 95, 96, 99-101, 112-116
- ARBMH50** 15, 38, 51, 54
- Assembly drawings** 104-111
- Auto rate controller** 8, 15, 39, 40, 46-49, 52-56, 71, 79, 117-120
- Axle** 14, 24, 104-111
- Basket & rinse** 15, 25, 27, 28, 30, 32, 33, 36, 51, 53, 62, 63, 67, 68, 104-116
- Bravo 180S controller** 15, 40, 47, 52-56, 71, 119
- Bystanders and children** 6, 53
- Calculate water & chemical quantities** 65, 80
- Calibration** 71, 72
- Chassis** 14, 23, 104-111
- Chemical disposal** 6, 29, 31, 32, 33
- Chemical probe** 15, 36, 37, 64
- Chemical probe operation** 53, 64
- Chemicals – working with** 6, 60, 61, 62, 64, 66
- Cleaning the sprayer** 66-69, 93
- Clearing blockages** 93, 96-102
- Confirming functionality** 50-54, 58
- Connection to tractor** 42-49
- Controller serial number** 5, 8
- Conversion chart, L/Ha to L/100M** 79, 81
- Croplands address** back cover
- Croplands customer service** back cover
- Croplands technical support** 103, back cover
- Croplands web site** 103, back cover
- Crush points** 6, 7
- Customer support** Back cover & croplands.com
- Date of publication** 4
- Diagnose problems** 55, 99-102
- Dimensions** 9-11
- Disc & Core chart** 77, 83
- Drain** 29, 30, 32, 33, 68, 69
- Drawbar** 14, 23, 44, 45, 104-111
- Dump valve** 35 i, 51, 52
- Electric brakes** 9-11
- Electrical connections** 6, 39, 46-49
- Emergency procedures** 6, 59
- Fan cleaning** 22, 58, 68
- Fan – Fieni** 12, 13, 17-22, 56, 104-111
- Fan leaf guard** 22
- Fan operational limits** 17, 20, 22
- Fan set-up** 17 ~21
- Fill camlock** 14, 27, 28, 30, 32, 33, 62, 67
- Fill flush tank** 26, 28, 30-31, 32, 33, 35, 51, 62, 67
- Fill handwash tank** 25~26, 28, 30-31, 32, 33, 35, 62
- Fill main tank** 25-26, 27, 28, 30, 31, 32. 33, 35, 51, 62
- Fill system** 14, 25-26, 35, 62-63
- Filter cleaning** 35, 50, 58, 60-61, 97-98, 99-101
- Filter mesh** 26 2, 35, 50, 58, 60-61, 96-98, 112-116 (Note: actual mesh is colour specific)
- Flotation tyres** 14, 24
- Flowmeter calibration** 55, 71-74
- Flushing after spraying** 66-68
- Flushing tank** 14, 25, 26, 27, 28, 30, 32, 33, 35, 51, 62, 99 - 69
- Gloves** 6, 25, 26, 50, 58, 60, 61, 64, 97
- Go spraying** 58, 59, 66
- Guards** 22, 58, 93, 94
- Hand wash tank** 14, 25, 26, 27, 28, 30, 31, 32, 33, 62, 112 - 116
- Hand wash tap** 14, 25, 27, 31, 32, 33, 104-111
- Highway speed** 6, 7, 8
- Hook-up controllers** 38 - 40, 42, 46 - 49, 51 - 56
- Hook-up sprayer** 42 - 45, 69
- HV2400 controller** 15, 39, 48, 52 - 56, 118
- HV4000 controller** 15, 39, 46, 52 - 56, 71, 117

SECTION 11

INDEX

- Important information** 4, 5
- In-line pressure filter** 61, 98
- Intended use of machine** 4, 12
- Jockey stands** 23, 42, 44, 50, 58, 69, 104 - 111
- Ladders & steps** 6, 14, 23
- Lid basket** 15, 25, 27, 28, 30, 32, 33, 36, 51, 53, 62, 63, 67, 68, 104-116 (see basket rinse)
- Liquid systems** 35 - 37, 50 - 56, 60 - 64, 66 - 68
- Litres per 100m / Row** 79, 81
- Loading & unloading** 6, 8, 42 -45
- Looms** 46- 49, 117-120
- Main tank** 14, 25, 27-33, 62, 104-111
- Maintenance – diaphragm pumps** 34, 58, 94 ~ 96, 99, 100
- Maintenance – filters** 26, 35, 50, 58, 60, 61, 96 ~ 98, 101
- Maintenance – general** 20, 58, 72, 73, 93, 94
- Maintenance – greasing schedules** 94
- Maintenance – service hours** 20, 94 ~ 98
- Manuals** 4, 5, 6, 34, 38 ~ 40, 71
- Non-Drip Diaphragms** 14, 21, 98
- Nozzle charts** 56, 71, 75, 82, 83
- Nozzles, roll-over bodies** 14, 21, 56, 57, 76, 98
- Nozzles selection** 14, 56, 57, 74 ~ 78
- Nufarm** 2
- NuPoint GPS tracking & mapping** 15, 46, 47
- Operator training** 6, 58, 60, 71
- Operational pointers** 66
- Operator responsibilities** 6, 59, 60, 71
- Parts list** 7, 82, 83, section 10
- Power lines** 6
- PPE (personal protective equipment)** 6
- Prestart checks** 6, 5-56, 58, 66
- Pre-operation checklist** 58
- Pressure gauge** 36, 54
- Pressure Gauge - Vent relief** 36
- Pressure plumbing** 35-40, 5-54
- Probe** 15, 36, 37, 64, 121
- Product features & familiarisation** Section 4, 16 ~ 40
- PTO fitment** 17, 18, 34, 42 - 45
- PTO maintenance** 58, 94 + PTO manual
- PTO safety** 6, 7, 34, 42, 43, 45, 50
- PTO Shafts** 6, 14, 20, 22, 34, 120
- Pump – diaphragm** 34, 50, 58, 96, 96, 99, 100
- Repairs** 93
- Risk assessment** 5, 6, 59, 60
- Road transport** 6, 7, 8, 42, 58, 59
- Safety chains** 5, 6, 45
- Safety first** 4, 5, 6, 7, 22, 34, 42, 45, 50, 58 ~ 64, 66, 93
- Safety manual** 5, 6
- Safety signs and decals** 4, 6, 7, 8, 22, 25, 45, 50, 62, 66
- Safety terminology** 4, 6
- Schematics – electrical** 117 ~ 120
- Schematics – plumbing** 112 - 116
- Schematics – sprayer assemblies** 105 ~ 111
- Sections controls - electrical** 35, 36, 39, 40, 102
- Section Controls - manual** 38
- Self-steer drawbar 2-point** 44, 69
- Serial number** 5, 8
- Sprayer set-up** 18, 21, section 5, 41 ~ 57
- Sight gauge** 14, 27 ~ 33
- Spray controller** 15, 38 ~ 40, 46 ~ 49, 51 ~ 56
- Spray pressure – adjusting** 35, 38, 39, 53 ~ 56
- Spray manifolds/rings** 17, 21, 36, 56, 57
- Fan cleaning** 22, 58, 68
- Sprayer identification** 5, 8
- Sprayer options** 13, 14, 15, 24, 39, 40

SECTION 11

INDEX

Sprayer specification 5, 12 ~ 15

Spraying calibration worksheet 76, 77, 85 ~ 92

Spraying on sloping or uneven ground 6, 66

Spraying steps 1 – 12

Flowmeter, checking & cleaning 72, 73

Determining actual speed of travel 74

Determining spraying volume required 74

Determining sprayer configuration 74

Determining ideal spray pressure 75

Determining correct nozzles 75, 76, 77

Fit & Test nozzles 78

Calculate actual application rate 78, 79

Check and retest application rates 79

Coverage assessment 79

Add chemical to the tank 80

Record data for future 80

Spraywise book 71

Step 6, 14, 23, 27, 106 ~ 110

Stopping 59, 69

Storage of sprayer 68, 69, section 8 inc p.96

Suction plumbing 35, 60 ~ 62, 96, 97, 99 ~ 101

Table of contents 3, 16, 41, 59, 70, 93, 103

Tank & equipment cleaners 68, 69

Tank draining 7, 27, 29 ~ 33, 50, 58, 67 ~ 69

Tank fill 14, 27 ~ 33, 35, 62

Tank level 27 ~ 33

Tank lids 14, 25, 26, 28, 30, 32, 33, 62, 63, 104 ~ 110

Tank Selection Valve 26, 35, 51, 53, 60, 63, 64, 66 ~ 68, 112 ~ 115

Technical support 103 & Croplands.com

Tow connection 6, 23, 42 ~ 45, 50, 69

Towing 6, 7, 8, 44, 69

Tractor requirements 5, 6, 7, 15, 17, 42

Tractor speed 5, 6, 7

Troubleshooting – diaphragm pumps 96, 99, 100

Troubleshooting – dump valve operation 101, 102

Troubleshooting – general sprayer problems 101

Troubleshooting – rate controller problems 55

Troubleshooting – motor valve problems 102

Tyre pressure 58

Unhitching the sprayer 69

Warranty 5, 95

Washdown 68, 69

Weather conditions 71, Spraywise

Weight & balance 8, 42, 44, 62

Wheel chocks 6, 62, 69

Wheels nuts 5, 7, 58

Wiring looms 46 ~ 49, 102, 116 ~ 119

Working environment 6, 66

Working on or underneath machines 6

Working together 6, 22, 66

CROPLANDS

AUSTRALIA

Croplands Equipment Pty Ltd
ACN 006 450 184

PO Box 2441
Dry Creek
50 Cavan Road
Dry Creek SA 5094
Australia

Freecall: 1800 999 162
Freefax: 1800 623 778
Email: sales@croplands.com.au
Website: www.croplands.com.au

NEW ZEALAND

Croplands Equipment Ltd
PO Box 2004,
Stortford Bridge, Hastings 4120

Location:
1422 Omaha Road,
Hastings 4120
New Zealand

Freecall: 0800 106 898
Freefax: 0800 117 711
Email: sales@croplands.co.nz
Website: www.croplands.co.nz

Your nearest Croplands Dealer
can be found in the dealer section
on the Croplands website