

# CROPLANDS

## Quantum Mist™

QM-500 Vineyard Sprayers



# Parts & Operator's Manual



**Foreword**

**Important Information**

---

**Section 1**

**Pre-Operation**

---

**Section 2**

**Sprayer Operation**

---

**Section 3**

**Sprayer Calibration**

---

**Section 4**

**Lubrication & Maintenance**

---

**Section 5**

**Trouble Shooting**

---

**Section 6**

**Assembly Drawings & Parts Listings**

---

**Section 7**

# Foreword

## About This Manual

This manual provides assembly, setting up, operating and maintenance instructions for the Croplands Quantum Mist™ sprayer.

Some features explained in this manual may not be installed on your sprayer.

Please pass on this manual with the sprayer at the time of resale for usage by the new owner.

## Terminology

These terms/symbols used throughout this manual:

- **NOTE** - to convey useful operating information.
- **CAUTION** - to highlight potential injury or machinery damage.
- **WARNING** - to stress potential dangers and the importance of personal safety.

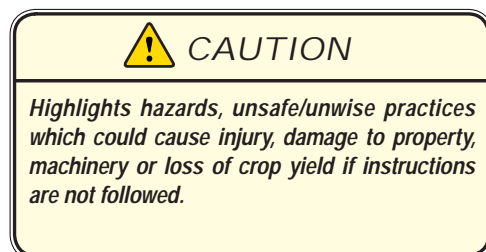
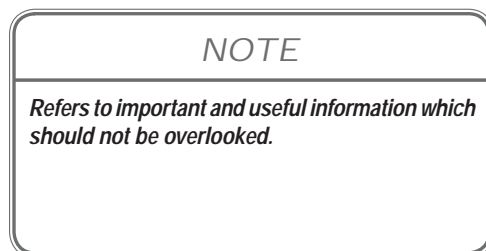

## Before Operating Your Sprayer

- 1 Before attempting to use your sprayer, make sure you **read the Operator's Manual** and properly understand:
  - All Safety Issues.
  - Assembly & Installation instructions.
  - Calibration of the sprayer.
  - Sprayer Operation.
  - Sprayer Maintenance.
- 2 Read and follow instructions on chemical manufacturers' labels.
- 3 Always wear applicable protective clothing.



*Read and understand this Operators' Manual before operating the sprayer.*



<b>Introduction</b>	<b>1.2</b>
<b>General Specifications</b>	<b>1.3</b>
<b>Warranty Policy</b>	<b>1.4</b>
<b>Safety</b>	<b>1.5</b>
<b>Shipping Information &amp; Product ID</b>	<b>1.6</b>



*Sean Mulvaney, General Manager of Croplands*

Congratulations on the purchase of your new Croplands sprayer.

Croplands have been in the business of building and selling spraying equipment since 1972. For over 40 years we have been supplying sprayers to farmers, contractors, growers and all our customers involved in growing crops and in the control of pests and diseases.

Croplands is a wholly owned subsidiary of Nufarm Ltd, the largest supplier of crop protection chemicals in Australasia, and one of the fastest growing global suppliers world-wide.

At Croplands, we pride ourselves on our commitment to supplying machinery that is at the forefront of the industry's needs. We believe we can back up our products and through constant research and development, bring to you the best equipment you can find.

We welcome any feedback from you about our equipment.

On this page you will find our contact details, and locations where our staff can be reached during business hours.

After hours, you can e-mail us and expect a reply the following morning.

Please read this manual in its entirety before you operate your sprayer. This will ensure you have a trouble-free start up.

In this manual you will find the parts listings you need should you have any breakdowns in the future.

Bear in mind that over time, some parts may become obsolete or be replaced with better options. You can contact us for alternative options if this is the case.

We trust you will get years of good use from your Croplands Sprayer.

Yours sincerely

Sean Mulvaney  
General Manager

Contact details:

## **AUSTRALIA**

Croplands Equipment Pty Ltd  
ACN 006 450 184  
PO Box 2441, Dry Creek  
50 Cavan Road, Dry Creek  
S.A. 5094  
Australia

FreePhone: 1800 999 162

FreeFax: 1800 623 778

e-mail: [sales@croplands.com.au](mailto:sales@croplands.com.au)

website: [www.croplands.com.au](http://www.croplands.com.au)

## **NEW ZEALAND**

Croplands Equipment Ltd  
PO Box 2004  
Stotford Lodge, Hastings 4120,  
1422 Omahu Road,  
Hastings 4120  
New Zealand

FreePhone: 0800 10 68 98

FreeFax: 0800 11 77 11

e-mail: [sales@croplands.com.au](mailto:sales@croplands.com.au)

website: [www.croplands.com.au](http://www.croplands.com.au)





2000 litre Quantum Mist.

## General Description & Specifications

The Quantum Mist™ vineyard sprayer comes in three basic configurations - single row, double row and three row.

Each machine has specific parts and chassis differences covered in this manual. The basic system and components are the same for all three configurations.

The Quantum Mist™ uses individual, hydraulically driven spray heads with SARDI 5-blade fans to give the maximum possible coverage in grapes and dwarf tree crops.

Using slower moving, high volume air, which is infinitely adjustable within the speed range, the heads are targeted to the canopy to make use of the turbulent air and low drift characteristics.

### Tank Sizes

1500, 2000, 3000 and 4000 litre tanks are available and are constructed of impact resistant polyethylene and UV stabilized.

Each tank has an incorporated flushing tank and a sight tube for filling level indication. All tanks drain completely via a large drain valve and sump.

Lid-strainers & chemical mixing baskets are standard on all models.

### Fans

Quantum mist fans are hydraulically driven by a case drained motor, coupled through a fully sealed double bearing-block with a rugged compression coupler bolted to the hub. The QM380 is driven by a 6.5cc motor, while the QM500 fan runs with a 9.8cc motor.

The cowl is of rotomolded material and designed for strength, light weight & durability.

The 5-blade fan has been scientifically designed for maximum air efficiency in the agricultural environment with excellent characteristics for canopy spraying.

Fully adjustable nozzles (6 on a QM380, 8 on a QM500), incorporated in the cowl design, provide maximum flexibility with liquid application rates.

A new liquid delivery ring ensures high water rates can be achieved if required.

### Hydraulic System

An integrated hydraulic control block takes care of all hydraulic functions and includes the main pressure relief valve, anti-cavitation valve, soft-start mechanism, two test ports (pressure and return).

This control block feeds the fan distribution manifold, which are suited to each machine (single, 2-row and 3-row).

An in-cab control device takes care of the folding & optional wing-lift/terracing/outer arm adjustment via electric over hydraulic valves.

All hydraulic supply is from the tractor to maximise efficiency of the sprayer/tractor combination.

### Nozzles

Each spray head comes with 6 or 8 nozzles depending on your choice of fan. These will achieve the owners desired application rate at the time of order.

Each nozzle is totally adjustable for canopy or bunchline spraying, and is integrated with the cowl design.

Spray rate capability for the Quantum Mist™ is from 150 to 3000+ L/ha.

### Pump & Drive

Quantum mist sprayers run with positive displacement diaphragm pumps, complete with oil backed HDPS diaphragms and chemical resistant anodized body. Depending on the sprayer model, an Annovi Reverberi pump with a capacity of 125, 160, 180 or 250 l/min will be fitted.

A heavy duty PTO shaft is supplied with all PTO driven pumps. This will be supplied to suit the drawbar fitted also.

Hydraulic driven pumps are also an option when a Hydraulic powerpack is fitted to the machine.

### Agitation

The agitation system is driven by the pump via venturi tank agitators & bypass agitation. Single supra-flow venturi on 1500 litre models, twin supra-flow venturis on 2000, 3000 & 4000 models.

### Filtration

Lid strainer, large suction filter, self-cleaning pressure filter & nozzle filters fitted.

### Chassis

Hot-dipped galvanised full-length heavy-duty chassis with optional suspension system, a choice of fixed or self-tracking drawbar, adjustable step & jockey stand.

On 2 & 3-row units, the hydraulic-fold over-row assembly is powder-coated and made from heavy duty steel.

### Controls

Choices include manual-tap controls, electric in-cab controls with or without pressure adjustment and fully auto-rate control.

All options are matched to the machine delivered.

### Wheels

Depending on model, wheel options are:

- 11.5/80 x15.3 wheels with tubeless tyres
- 400 x 15.5 flotation wheels & tyres
- Tandem axle simplicity suspension available with 15" Landcruiser or 11.5/80 x 15.3 wheels depending on sprayer model.

### Suspension

Standard axle suspension is fitted on the 2000, 3000 & 4000 litre models.

**Power required** at the PTO on flat terrain:

- Single-row - 25 HP
- 2-row - 40 HP
- 3-row - 65 HP

### Options

Options include electric or auto-rate controls, self-tracking drawbar, wheels as listed above, hydraulic terracing kit, hydraulic outer row adjustment kit, wing-lift kit.

A self contained hydraulic powerpack and hydraulic driven pump is also an option.

Chemical suction probe, quick-fill system, hydraulic pressure filter.

8 x additional nozzles on double-nozzle bodies per head.

*Machine specifications are subject to change without prior notification.*

# SECTION 1

## WARRANTY POLICY

Each sprayer will be delivered with a Warranty & Pre-Delivery Booklet which includes:

- the Sprayer's unique serial number,
- the Sprayer's specification sheet,
- a pre-delivery checklist and
- outlines the Croplands Warranty policy.

Always contact your Croplands Dealer first and foremost for warranty matters.

### NOTE

For full conditions of warranty and warranty policy, please see the Warranty & Pre-Delivery booklet provided with this sprayer.

# CROPLANDS

## SPRAYER SPECIFICATIONS WARRANTY & PRE-DELIVERY HORTICULTURE

[WWW.CROPLANDS.COM.AU](http://WWW.CROPLANDS.COM.AU)

### STOP

BEFORE COMMENCING operation, **ENSURE** you read & understand this manual, its contents, and any additional information supplied.



GP-WARH-A | updated Jan 2021



# SECTION 1

## SAFETY

### SAFETY FIRST

Please read and understand all supplied manuals, guides and safety decals before operating this sprayer. This includes the **Croplands Operators Safety Manual** – as pictured here.

This manual is available on the Croplands Web site, or for printed versions contact Croplands customer support and ask for part number GP-SAFE-A (or later version if available).





Use tie-down points provided when transporting.



2000 litre Quantum Mist.



Quantum Mist Serial Number (A)

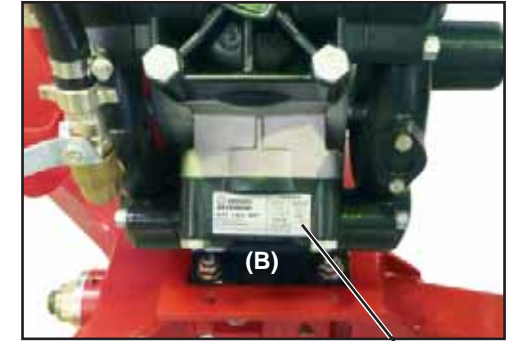

AR Pump Serial Number (B)

## Shipping Information

The following shipping information is provided but variations can occur without prior notification.

### Approx Weight

Model	Boom	Dry Weight (kg)
1500	Single-row	740
2000	Single-row	780
4000	Single-row	TBA
2000	Double-row	1340
4000	Double-row	TBA
4000	Three-row	2160

### Maximum Towing Speed

Do not exceed 25 kph when towing on roads.

### Dimensions (Approximately)

Model	Boom (folded)	L(m)	x	W(m)	x	H(m)
1500	Single-row	3.9	x	1.5	x	2.6
2000	Single-row	4.3	x	1.6	x	2.6
4000	Single-row	4.3	x	1.9	x	2.7
2000	Double-row	4.8	x	2.0	x	2.7
4000	Double-row	5.0	x	2.25	x	2.7
4000	Three-row	5.7	x	2.25	x	2.7

## Product Identification

Always use the serial number of the Quantum Mist when requesting service information or when ordering parts.

Early or later models (identification made by serial number) may use different parts, or it may be necessary to use a different procedure for specific service operations.

## Quantum Mist Serial Number Plate

The Quantum Mist Serial Number Plate is located on the main frame at the front of the left hand wheel (A).

This plate shows name of manufacturer, serial number, product code and date of manufacture.

## Pump Serial Number Plate

The Pump Serial Number Plate is located on the pump (B).

This plate shows name of manufacturer, serial number, type of pump, year of manufacture, maximum flow rate and maximum working pressure of the pump.

<b>Hook-up</b>	<b>2.2</b>
<b>Unhitching</b>	<b>2.9</b>
<b>Pre-Operation Check</b>	<b>2.10</b>



2000 litre Quantum Mist.



Optional self-tracking drawbar.



Hitch fitted in the lower position.

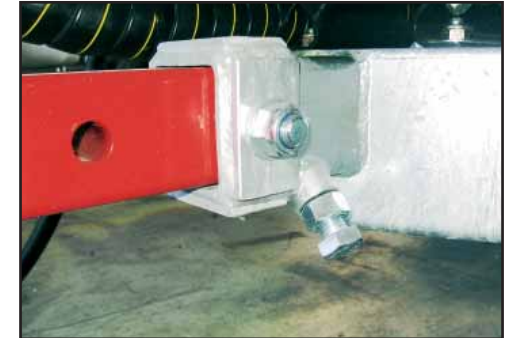

Loosen the bolts and locking nuts that hold the hitch.

## Assembly Instructions

The Quantum Mist™ is supplied fully assembled with the following components requiring some assembly after shipping from the factory:

- 1 Connect the Quantum Mist™ and PTO shaft to the tractor (see pages 2.12-2.13).
- 2 Fit the hydraulic hoses to the tractor.
- 3 Fit the spray controller to the tractor:
  - Manual Controls
  - Electric Controller
  - Auto Rate Controller (if ordered).
  - Flowtrak Monitor (if ordered).
- 4 Fit the Boom controls to the tractor (if purchased).

### 1 Connect the Quantum Mist to the Tractor

The Quantum Mist™ must be connected to a suitable tractor, making sure the drawbar and PTO shaft are fitted according to the instructions that follow:

- 1 Align drawbars of tractor and Quantum Mist™, then insert & lock the drawbar pin in position ensuring it cannot come out while transporting or operating.  
Lift up and/or remove the hitch jack for sprayer operation.
- 2 Check the Quantum Mist™ is level fore and aft. The sprayer should be slightly lower at the front (up to approximately 3 degrees). If not make the necessary adjustments to tractor and/or sprayer drawbars and axle to achieve level position (see pages 2.10 - 2.11).

#### NOTE

When connected to your tractor drawbar, the Quantum Mist should be level or slope slightly downwards at the front.

### Hitch Adjustment

The Quantum Mist™ standard hitch can be adjusted for height and length to match your tractor drawbar.

#### 1 Height Adjustment

To adjust the height of the Quantum Mist™ hitch:

- a) Make sure the Quantum Mist™ cannot roll.

Support the front of the frame and remove the hitch jack.

Hitch fitted in the upper position.



- b) Loosen the locking nut and bolt under the Quantum Mist™ hitch.
- c) Remove the nut and then the bolt that goes through the hitch.
- d) Slide the hitch out of the Quantum Mist™ frame, turn it the other way up and then slide it back into the frame.
- e) Replace the bolt through the hitch and then the locking nut.
- f) Retighten bolt and the locking nut under the Quantum Mist™ hitch.
- g) Refit the hitch jack.
- h) Connect trailer towing safety chains (not on self steer drawbars).

#### NOTE

When connected to your tractor drawbar, the drawbar pin connecting the tractor and Quantum Mist™ should be centred between the two universal joints of a PTO shaft (see illustration on page 2.12), except where a constant velocity drive shaft is being used.

Where a constant velocity drive shaft is used, the towing pivot point should be as close as possible to the constant velocity joint of the driveshaft (see the illustration on page 2.13).



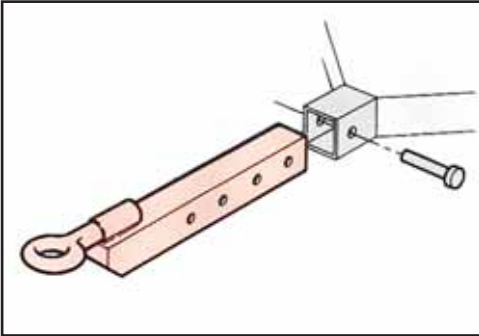

Select the hole position to set hitch length.

## 2 Length Adjustment

To adjust the length of the Quantum Mist™ hitch:

- Make sure the Quantum Mist™ cannot roll.  
Support the front of the frame and remove the hitch jack.
- Loosen the locking nut and bolt under the Quantum Mist™ hitch.
- Remove the nut and then the bolt that goes through the hitch.
- Slide the hitch in out of the Quantum Mist™ frame to the length required.
- Replace the bolt through the hitch and then the locking nut.
- Retighten bolt and the locking nut under the Quantum Mist™ hitch.



Optional self-tracking drawbar.

## Self-Tracking Drawbar

If your Quantum Mist is fitted with a self-tracking drawbar, ensure the pivot points are greased regularly (every spray-round).

To adjust the self-tracking drawbar length, follow the steps as instructed for "Length Adjustment" (shown left) for the standard drawbar hitch.

With the pump mounted on the top of the self-tracking drawbar, the PTO shaft will remain unchanged in length & direction during turning.

Ensure the drawbar is cut to the correct length for your tractor prior to operation & that the PTO shaft is greased every 4 hours during operation.

See your dealer about cutting the PTO to the correct length.

For more instruction on the self-tracking drawbar, see page 2.13.



Spring suspension axle.

## Optional Suspension Axle

The two row Quantum Mist is fitted standard with a spring suspension axle.

The axle can be adjusted along the chassis if necessary for weight balance and stability.

Tandem axle options are available.

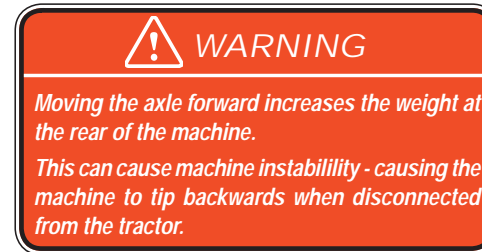

Optional Tandem Axle.



Optional self-contained hydraulic system & self-tracking drawbar.

## Self-Contained Hydraulic Option

If your Quantum Mist is fitted with a self-contained hydraulic option, ensure the pivot points are greased regularly (every spray-round).

Axle spring.

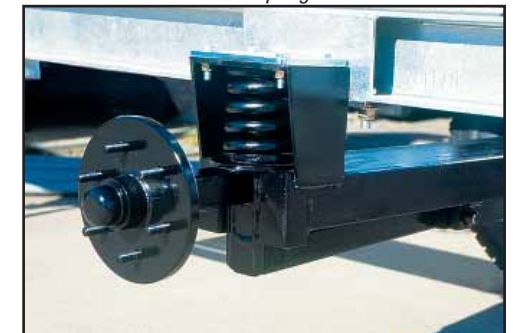



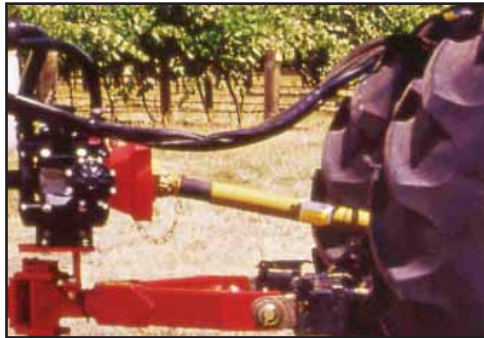

Connect the Quantum Mist™ to the tractor.

## 2 Fit the PTO Shaft

The PTO shaft is inspected at the factory and is disconnected and packed for transit.

Follow the instructions below to fit the PTO shaft onto the Quantum Mist™ after transit:

- 1 Remove the PTO shaft which is strapped to the Quantum Mist™ frame.
- 2 Check the PTO shaft has not been damaged in transit.
- 3 Grease the universal joints, telescoping shafts & safety cover bushes.
- 4 Measure and fit the PTO to the Quantum Mist ensuring the locking pin is correctly located.

Make sure you read and understand “Important factors for fitting the PTO shaft” on the next page.

**Cutting the PTO shaft to length requires knowledge of this procedure. If you have not carried out this procedure before, ensure your dealer carries out this important step.**

- 5 Before operating the drive shaft, be sure that all safety guards are in place & safety chains are securely fitted.
- 6 **Do not exceed maximum RPM of the pump or gearbox (550 RPM).**

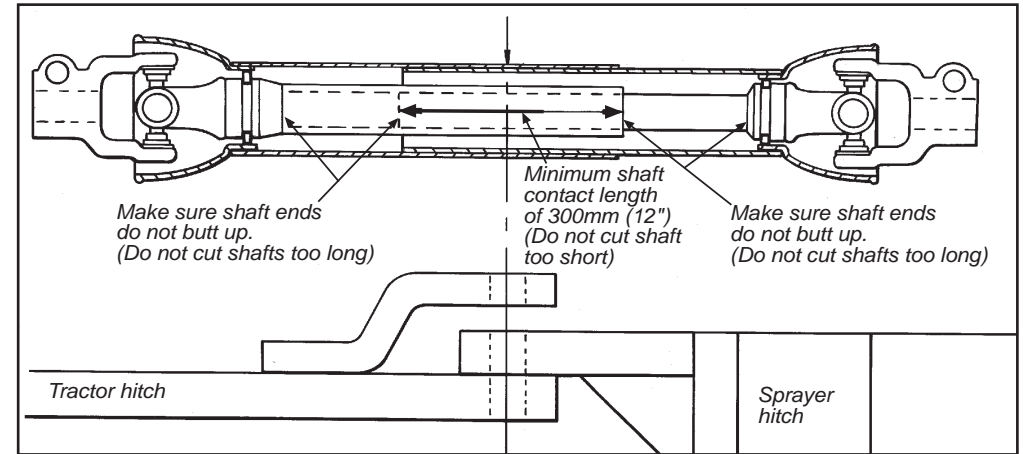

On Standard PTO shafts, the drawbar pin connecting the tractor & Quantum Mist should be centred between the two universal joints of the PTO shaft. For wide angle (constant velocity) shafts, see page 2.12 for alternative settings.

## Important Factors when Fitting the PTO Shaft

The following three factors must be correct to avoid pump damage and maximise PTO operating life:

- 1 When travelling straight ahead, the point at which the sprayer drawbar pin is joined to the tractor should be as close to halfway as possible between the universal joints of a Standard PTO shaft, as illustrated.

The tractor is then able to make maximum turns with minimal bending of the universals.

- 2 When the tractor is towing the sprayer straight ahead, the two telescopic sections of the power take-off shaft are at maximum extension.

When turning or crossing an inversion, the telescopic shaft length will vary.

### NOTE

Full instructions are given on the following pages to ensure the PTO is set-up correctly BEFORE use.

If you are inexperienced in the procedures, this step should be carried out by your dealer.

### NOTE

Incorrect hitching of PTO shaft will result in excessive pump vibration and damage to the pump.

### NOTE

**IMPORTANT:** Do not allow more than 10% difference in the two halves of drawbar length. If more than 10% difference occurs, a wide angle shaft must be used.

### CAUTION

Ensure that the drive shaft is the correct length to avoid any "butt up" damage to the pump.

## Standard PTO

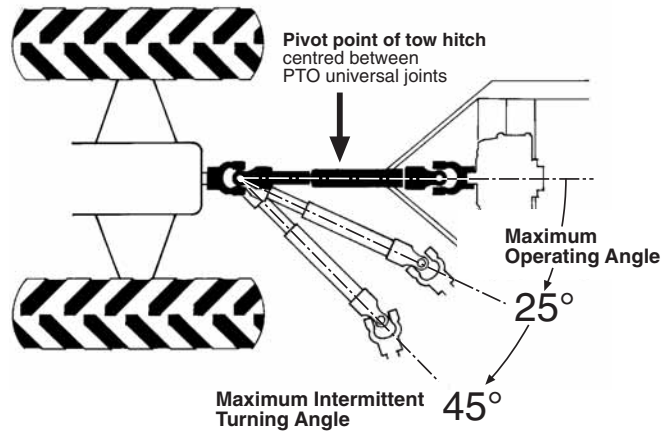

- The height difference between the tractor PTO spline and the PTO spline of Quantum Mist should not be more than 100mm.

This ensures PTO joint angles are approx equal and do not exceed limits. If greater than 100mm, a wide angle (constant velocity) PTO should be used.

See Hitch height adjustment instructions on page 2.9.

## Heed the Operating Limits of the Standard PTO Shaft

The standard Quantum Mist is fitted with a STANDARD PTO shaft.

The maximum intermittent turning angles of the Standard PTO shaft is only recommended where should not exceed 45° turning angle of the PTO.

Standard PTO Operating Limits

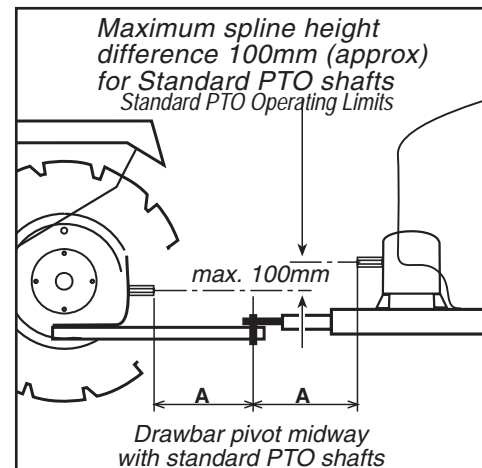

### CAUTION

Pump warranty is not valid for damage caused by incorrect PTO shaft mounting.

## Optional Wide Angle (Constant Velocity) PTO

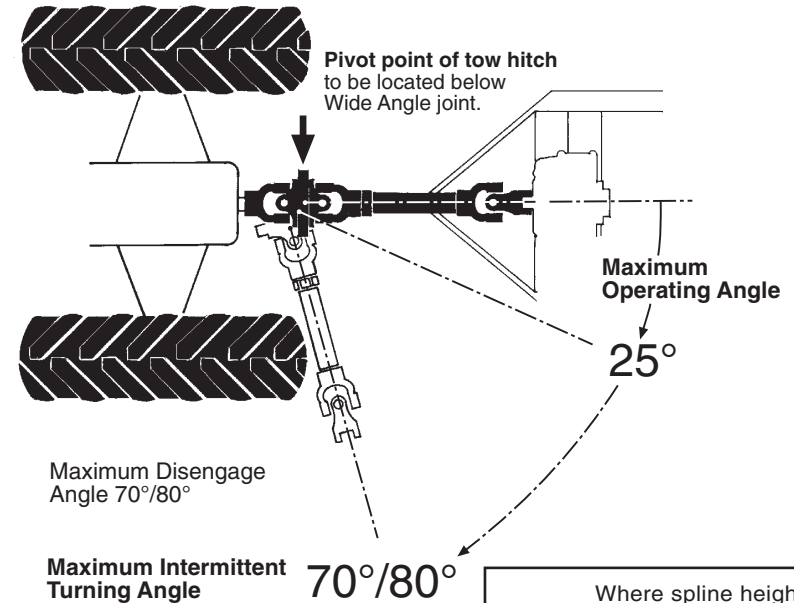

## Optional Wide Angle PTO

The wide angle (constant velocity) PTO or swivel drawbar must be used where tight turning requires greater than 45° turning angle of the PTO shaft.

Where height variance between the tractor output spline and Quantum Mist™ input shaft is greater than 100mm, a wide angle (constant velocity) PTO must be used.

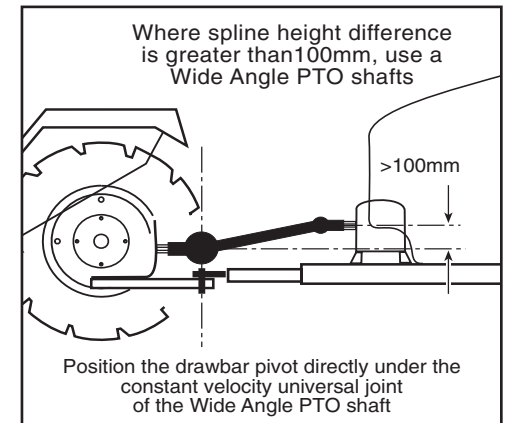

### WARNING

Always operate the PTO fitted to your Quantum Mist™ within the specified limits. Follow the information on pages 2.12 - 2.13.

Failure to operate the PTO as instructed can result in serious damage to the pump, PTO and any components connected to the drive train of the tractor and Quantum Mist. Incorrect operating will void warranty claims.



Optional self-tracking drawbar.

## Optional Self-Tracking Drawbar

The self-tracking drawbar can be used where tight turning requires greater than 45° turning angle of a PTO shaft and in lieu of the wide angle PTO option.

It is also suitable for ensuring the sprayer wheels track on the same lines as those of the tractor to make row exit & entry easier.

Follow the instructions below to connect the self-tracking drawbar to the tractor:

- 1 Connect the tractor linkage arms to the self-tracking drawbar linkage pins Cat 1 & fit the holding clips.



Failure to lock linkage arms may cause damage or injury.

- 2 Ensure the sprayer chassis is horizontal (it may be up to approximately 3 degrees lower at the front).
- 3 Fit locking bars to lock the tractor linkage arms into position.

**Important:** Locking bars must be fitted to tractor linkage arms to prevent the sprayer tipping up and causing damage or injury.

- 4 Fit the PTO shaft to the tractor and to the sprayer pump.

Ensure the PTO shaft is cut to the correct length.

### NOTE

*When connected to your tractor drawbar, the drawbar pin connecting the tractor and Quantum Mist™ should be centred between the two universal joints of a PTO shaft (see illustration on page 2.12), except where a constant velocity drive shaft is being used.*

*Where a constant velocity drive shaft is used, the towing pivot point should be as close as possible to the constant velocity joint of the driveshaft (see the illustration on page 2.13).*



3/4" female back-to-tank return fitting supplied with the Quantum Mist.

## 3 Connect the Hydraulic Hoses to the Tractor

Once the hitch & PTO adjustments are complete, it is important to correctly set up the hydraulic supply for the tractor.

Your dealer will carry out this step to ensure no damage or warranty issues will result from incorrect set up.

A small charge may be incurred for this procedure.

A 3/4" return fitting is supplied with your Quantum Mist.

This is the DIRECT BACK-TO-TANK fitting required to ensure there is no back-pressure on the oil return from the Quantum Mist sprayer.



Return fitting installed and ready for hook-up of the return line.

On all models, it is important that these steps are done - to make it easy for you to use your sprayer, and to protect the sprayer's hydraulic system:

- 1 Ask your dealer to fit the 3/4" female return coupler direct back-to-tank.
- 2 Decide on the best supply remote on your tractor to use for oil supply for the fan system.

### NOTE

*It is recommended to mark each of the hoses and the tractor remotes with cable ties or coloured markers once the hoses are in place. This will ensure that any operator in the future can easily hook up your Quantum Mist sprayer in the future.*

*Electric in-cab switch for left/right fold & unfold of outer booms (over-row models only).*

### WARNING

*Locking bars must be fitted to tractor linkage arms to prevent the sprayer tipping up and causing damage or injury.*

*Failure to lock the tractor linkage arms may cause damage or injury.*

### WARNING

*Tight turning in excess of 80 degrees with the self-tracking drawbar will result in damage to the pump and pump mounting.*



Connect hydraulic hoses to the tractor.

- 3 Plug the 1/2" oil supply line coupling to your selected remote and ensure the hydraulic line does not foul your PTO or any working parts at the rear of the tractor.

Allow sufficient slack in the hydraulic line for turning.

- 4 Hook up the 3/4" return line to the tractor.

As with the pressure line, ensure there is sufficient slack & no interference with tractor working parts.

For instructions on the operation of hydraulic systems, refer to pages 2.17-2.18.

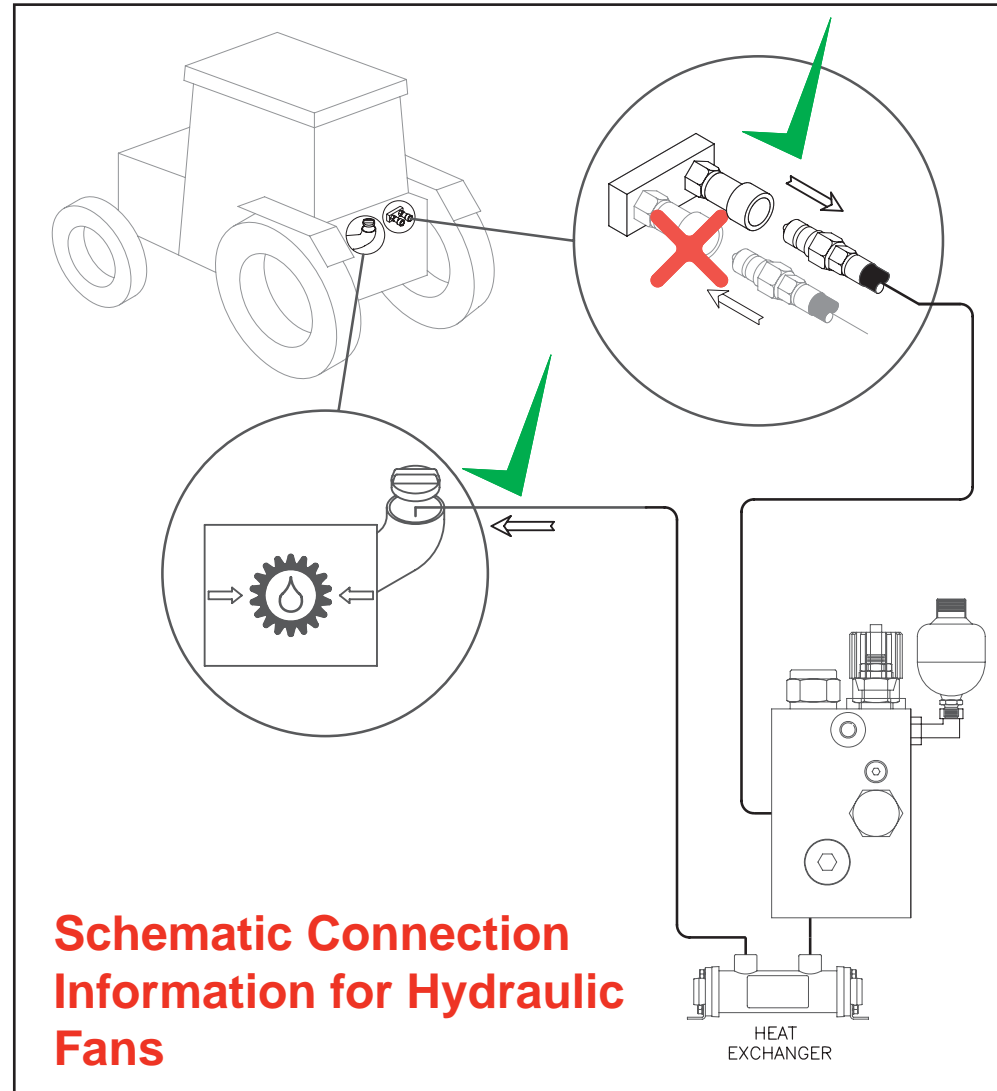

Connect the Tower fold/unfold hoses to the tractor (Fold Tower models only).

## Connect the Boom Arm Hydraulic Hoses (Fold Tower models only)

Follow the steps below to connect the boom arm fold/unfold hydraulic hoses (Fold Tower models only):

- 1 As with the hydraulic oil supply lines, select the appropriate remotes at the rear of the tractor for the fold/unfold hydraulic supply hoses.  
  
Plug the hoses in, again ensuring there is no interference with tractor working parts or the PTO shaft, and ensure there is enough slack in the hoses to allow easy turning.
- 2 The boom arm adjust function has an electric selector valve on the sprayer to select left from right with an in-cab control.

### CAUTION

Ensure all hydraulic connectors are clean prior to connection otherwise, damage to the hydraulic system may occur.





*In-cab control switch for fold/unfold and wiring connector.*

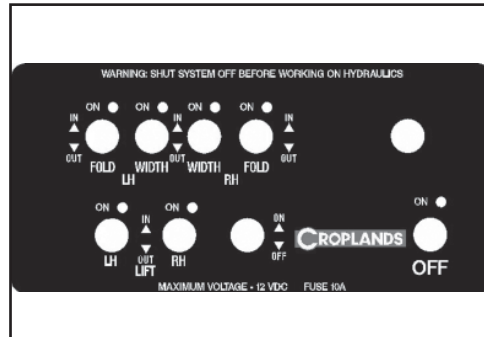

*Multi-function switch box.*



*Electric controller.*



*Auto Rate Controllers*

### Fit the Electric In-Cab Switch for the Upper Boom (Option only)

Follow the instructions below to connect the electric in-cab switch for left/right fold & unfold of upper arms:

- 1 Unpack the switch box and secure it in a convenient location in the tractor cab.
- 2 Run the power cable to for the in-cab control switch to a reliable power source. This switch requires good power, so direct to battery is recommended.  
  
Ensure the RED wire is attached to the positive terminal & the BLACK wire to negative.
- 3 Connect the loom from the cab to the loom from the sprayer and ensure the wiring cannot interfere with the PTO shaft or any tractor functions.

### 4 Fit the Controller to the Tractor

Follow the appropriate instructions to fit the controller to the tractor.

#### Electric Controller (if ordered)

When ordered, the electric controller has been fitted and fully tested at the factory but has been disconnected and packed for transit.

Follow the instructions below to fit the unit after transit:

- 1 Unpack the electric controller from the Quantum Mist.
- 2 Connect the electric controller couplings together, and fit the controller console onto the tractor in a convenient & safe location for the operator.
- 3 Follow the electric controller instructions to connect the unit power connections to the tractor battery.
- 4 Follow instructions to test, calibrate and operate the controller.

#### Auto Rate Controller (if ordered)

When ordered, the Auto Rate Controller has been fitted and fully tested at the factory but has been disconnected and packed for transit.

Follow the instructions below to fit the unit after transit:

- 1 Unpack the Auto Rate Controller from the Quantum Mist™.
- 2 Connect the Auto Rate Controller couplings together, and fit the controller console onto the tractor in a convenient and safe location for the operator.
- 3 Locate the Auto Rate Controller operators manual and follow the instructions to connect the unit power connections to the tractor battery.
- 4 Follow the instructions in the Auto Rate Controller operators manual to test, calibrate and operate the controller.





*Flowtrak monitor.*

## Flowtrak Monitor (if ordered)

When ordered, the Flowtrak monitor has been fitted and fully tested at the factory but has been disconnected and packed for transit.

Follow the instructions below to fit the unit after transit:

- 1 Unpack the Flowtrak monitor from the Quantum Mist™.
- 2 Connect the Flowtrak monitor couplings together, and fit the monitor console onto the tractor in a convenient and safe location for the operator.
- 3 Follow the Flowtrak monitor instructions to connect the unit power connections to the tractor battery.
- 4 Follow instructions to test, calibrate and operate the monitor.



*Attach & adjust hitch jack before removing drawbar pin.*

## Unhitching the Quantum Mist from the Tractor

- 1 Locate sprayer on level ground and block the wheels so that sprayer does not roll when drawbar pin is removed.
- 2 Disconnect PTO shaft, hydraulic hoses, hydraulic & spray controllers from the tractor.
- 3 Attach and adjust the hitch jack and then remove the drawbar pin.
- 4 Ensure caps for the hydraulic fittings are utilised to prevent dust & dirt entering you tractor hydraulic system next time you operate your Quantum Mist.
- 5 Put caps (supplied) on the loom plugs if you have the Auto Rate Controller fitted.

Model	Single Row	2-Row	3-Row
No of heads	4	8	12
Oil requirement	22 l/min @ 2700 psi*	44 l/min @ 2700 psi*	66 l/min @ 2700 psi*

\*as tested at the hydraulic control block – see “testing hydraulic pressure, Step 3” in this section.

Tractor hydraulic requirements.

## Check the Fan Hydraulics

### 1 Tractor Oil Supply (standard)

The hydraulic circuit on the Quantum Mist is powered from the oil supply of your tractor.

The table above shows the oil requirements, at the tractor remotes, for each model of Quantum Mist.

Your oil flow and pressure may be adjusted on the tractor once your maximum pressure is set. This allows you to vary your air speed and volume at your tractor to suit the canopy size and density.

If you have an HV4000 controller with fan speed adjustment fitted, air speed and volume can be adjusted through the console.

The quantum mist is fitted with an auxiliary heat exchanger to ensure oil is cooled before it returns to the tractor.



Auxillary heat exchanger.

The heat exchanger is fitted with a constant liquid supply through an orifice from the pump.

Note: If the D6 orifice is missing, this will result in a system pressure drop.

The heat exchanger also has a flushing switch on the UCM connecting to this line, to flush chemical out at the end of the operation.



Constant liquid supply to heat exchanger with orifice.



Left hand UCM switch for Heat Exchange Flushing shown in the 'ON' position

### NOTE

#### NOTES ON AIR ADJUSTMENT:

Once the maximum air speed is set with the PRV as described on page 2.17, the manual Pressure/Flow can be used to adjust you air speed & volume at any time to suit you canopy requirements.

A full report, called the "Independent Quantum Mist Report", prepared by SARDI for Croplands, explains the best set-up and air requirements at full crop-loading in sprawl-type canopies.

Testing of the Quantum Mist is continuing on other

canopy types and trimmed or "managed" canopies. What we do know is that full air-speed at 2000 rpm (fan RPM) is detrimental to spray coverage during the early season spray period.

When the canopy is still "soft" (shoots & leaves not fully developed), there is a tendency for too much air to "ball-up" to canopy and decrease coverage.

Slow moving, softer air will do much better job in these circumstances.

As a rule of thumb, you can consider starting off at bud break through to 15cm shoot length stage with

the fan speed set at 1500 RPM (& subsequent air output) to 1750 RPM, up until the canopy is filled out and flowers are formed (pre-flowering).

From flowering onwards, full speed (2000 RPM) and air speed/volume is recommended, although this will depend on how developed your canopy is.

For mechanically pruned vines, full air speed/volume may be necessary at an earlier stage.

Air speed/volume requirements will differ from

vineyard to vineyard. Experimenting and consulting your agronomist or advisor will be needed to determine you best spray coverage options.



Hook up the hydraulic supply & return lines to the tractor.



Loosen the lock nut on the PRV.



Adjust the PRV with the hex key.



Set maximum pressure on the TPP port to the required pressure.

### The following steps must be performed by your dealer, on your tractor:

It is recommended you follow the steps with you dealer to ensure you understand the process for future reference.

Although this procedure is already done at the factory, each tractor is different and will require adjustments on the sprayer.

### Step 1

Connect the hydraulic hoses to the tractor. The larger hose (3/4") is the RETURN hose, and must be fitted into the 3/4" hydraulic fitting supplied and fed directly back to tank.

The setup of the 3/4" back-to-tank female hydraulic fitting will be done by your dealer.

The pressure line is the smaller diameter hydraulic hose with a 1/2" male hydraulic fitting on the end.

This is connected to the remote of your choice and is the main oil supply to the sprayer, from the tractor.

### Step 2

Engage the hydraulic remote lever in the cab that corresponds to the remote you are using for your fan hydraulic supply.

Ensure your tractor revs are operating at the recommended RPM to achieve required oil flow/pressure from the tractor.

In general, if the oil pump on the tractor is in good condition, this can be achieved at about 60% of full power.

After 5 seconds or so, the fans will start to rotate.

### Step 3

This step requires specialised tools, so your dealer will show you how & why this is done.

At the front hydraulic control block, attach a test gauge to the pressure test port (marked TPP).

Using the correct spanner, undo the lock-nut on the pressure relief valve assembly, and using the correct hexagonal allen-key, adjust the PRV to achieve desired oil pressure.

The standard setting is 2750 psi, and this is also maximum recommended pressure.

### NOTE

The left/right fold hydraulic lines require a separate set of remotes as explained on page 2.14 of this manual.

### CAUTION

Maximum allowable pressure at TPT Port is 6 BAR.

Recommended operating pressure should not exceed 4 BAR.





Maximum pressure at TPT (low pressure port) should not exceed 6 BAR (4 BAR during operation).

If desired, and if your tractor has sufficient oil pressure & flow, you can adjust the pressure up to 2800psi at the control block.

Tighten the lock-nut and recheck the pressure on the gauge.



Check fan speed using an RPM meter.

### Step 4

Your dealer should now check the RPM of the fans to ensure they are operating at 2200 RPM (standard full speed) using an RPM meter.

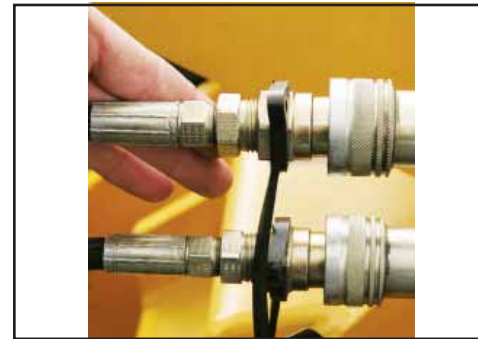

Plug boom-fold hydraulic hoses into tractor remotes.

## 2 Independent Oil Supply Models (Built Only to Order)

In some situations, an independent oil-supply model of the Quantum Mist is supplied.

If you have taken delivery of this model, the set-up procedures are slightly different than the tractor oil-supply model (standard).



Independent oil supply fitted with hydraulic drive pump.

For adjustment of oil pressure, the procedure is the same as for the tractor supply model.

The pressure will have been *factory set*, and **will not** require adjustment.

However, if adjustment is required in the future (after service work or maintenance), the procedure for setting the base pressure is the same as is described in steps 3 & 4 on the previous page.



*Optional PTO driven hydraulic pack.*

The tractor must be running and the PTO engaged to perform pressure adjustment as the oil pump on the sprayer is driven by the tractor PTO.

The left/right fold of the boom arms is controlled via the tractor remotes, so there are two hoses for pressure and return that should be plugged into the tractor remotes.



*Optional PTO mounted hydraulic supply.*

An in-cab control for left/right fold is supplied and will need to be wired direct to battery.

The product pump will be driven hydraulically from the tractor with this option.

The product pump speed (max 540 rpm) should be set using the flow control valve on the tractor (if available), and the bypass valve on the the hydraulic motor closed (needle valve) or max flow to priority setting on other valves.





Read Operators' Manuals before operating machine.

## Pre-Operation Checklist

- 1 Before attempting to use this machine, Read Operator's Manuals thoroughly.
- 2 Read and follow instructions on chemical manufacturers labels.
- 3 Always wear applicable protective clothing.
- 4 Check that all maintenance procedures have been followed.
- 5 Check all plumbing and fittings to ensure they are tight, not damaged or leaking.
- 6 Check PTO shaft is correctly set up.
- 7 Grease the PTO shaft if necessary.
- 8 Ensure the PTO safety chains are fitted securely.



Check pump oil level.

- 9 Check diaphragm pump oil level.
- 10 Check air pressure in the diaphragm pump air chamber is 70 - 100 kPa (10-15 psi). As a general guideline it should be 10% - 20% of operating pressure.

Check pump air chamber pressure.



Check suction filter is clean.

- 11 Check that the suction and pressure filters are clean.  
**Clean the suction and pressure filters out after initial use, and nozzles if necessary.**



For filling, use the main lid with the basket filter in place.

- 12 Check overall spraying functions using the:  
The Electric controller - (Refer to "Check Electric Controller Operation" instructions page 2.21).  
OR  
The Auto Rate Controller - (Refer to "Check Auto Rate Controller Operation" instructions page 2.22).

### NOTE

**IMPORTANT:** Clean the suction filter out after initial use.

Whilst all precautions are taken during assembly, it is possible to get fillings in the tank and lines. These will accumulate in the suction filter during first use.



Adjust the sprayer pressure with the pressure-control knob.



Test the operation of the selector valves.



The pump suction valve OPEN to the main spray tank.



Front and rear tank agitator valves in ON position.

## Check the Operation of the Quantum Mist

To check the operation of the Quantum Mist, there are three sections to consider:

- 1 Manual-tap controls
- 2 Electric controls
- 3 Auto Spray Rate Controllers (2 options)

For all three pre-operation checks, ensure you have sufficient clean water in the sprayer, and the pump suction valve is open for sourcing liquid from the main tank.

### 1 Manual-Tap Controls

If your Quantum Mist is fitted with standard manual-tap controls, the UCM Manual Control Unit will come with a remote-mount kit to attach the unit to the tractor.

- a) Fit the control unit to the tractor where the operator can best access it.
- b) Fit the pressure and bypass lines to the controller and ensure they are tight (no leaks)
- c) Wind the pressure control knob anti-clockwise to ensure the sprayer starts up with limited pressure.

- d) Start the pump by engaging the PTO from the tractor and operate at your required revs.
- e) Turn on the LEFT & RIGHT selector taps to start the nozzles spraying.

The fans do not have to be engaged during this process.

Make sure you have your chosen nozzle selection fitted to the sprayer so that your application will be correct.

- f) Slowly wind the pressure control knob clockwise until your chosen operating pressure is reached.

Maximum recommended pressure is 12 bar.

- g) Check LEFT/RIGHT operation with the selector taps.

### WARNING

**Important:** Do not have pesticides in the spray tank when checking the sprayer.

### NOTE

Maximum PTO speed for the pump is 540 RPM. It is recommended that a minimum of 400 RPM is used for best results.

### WARNING

Always ensure the sprayer controls are turned off, hydraulic fan drive and PTO disengaged when making any repairs or adjustments. Making adjustments while sprayer is operating can lead to serious injury.



Fit the electric control console in the cab and wire the power cable to the battery.

## 2 Electric Controls (Optional)

If your Quantum Mist is fitted with electric controls, the control panel and wiring loom for the tractor end will be supplied, ready to connect to the sprayer.

Complete the following steps to test the electric controls:

- Fit the electric control panel in a convenient location for the operator.
- Wire the control console power cable direct to the battery, ensuring the positive and negative polarity is correct.

Check the tank agitator & adjust angle if necessary.



Test master ON/OFF and LEFT/RIGHT functions.

- Connect the control console tractor-end loom to the sprayer-end loom.
- Flick the Master switch to ON, then test the left & right switches by listening to hear if the left/right valves open and close.
- Flick the Master switch to OFF. Start the tractor and engage the PTO to the sprayer.  
Ensure you have your chosen nozzle selection fitted to the sprayer so that your application will be correct.
- Turn the LEFT & RIGHT and Master Switch to the ON position. If the sprayer has a pressure UP/DOWN option, press and hold the pressure UP switch (▲) until maximum pressure is reached.



If fitted, test pressure UP/DOWN switch and ensure maximum pressure is 12 bar.

- With the nozzles still going, adjust the main pressure control knob (PRV) on the sprayer itself by winding it in or out until the maximum operating pressure is set to 12 bar on the gauge.  
Ensure you have the agitators on during this procedure.
- Back at the control console, check the LEFT/RIGHT operation of the electric valves, and the Master ON/OFF function.



Adjust pressure control knob (PRV) if required.

- If the sprayer has a pressure UP/DOWN (▲▼) switch, press the UP/DOWN switch in both directions and check the gauge so that spraying pressure can be controlled from 0-12 bar using the UP/DOWN switch.  
If not, re-adjust the PRV on the sprayer.

### NOTE

With electric in-cab controls, the electric LEFT/RIGHT valves will bypass the liquid back to the tank when the switch is in the OFF position.

This is to protect the sprayer from any over-pressure during shut-off.

Your electric controls are an important part of the sprayer. Look after them and store them correctly when not in use.

If the electric controls are not functioning, contact your dealer.





Compensator section valves.



Auto Rate Controllers



Fit the console in the cab & wire power cables to the battery.



Hold the pressure up switch until maximum pressure is achieved.

## To calibrate:

- 1) Turn one section valve off at your controller while leaving the others running.
- 2) Adjust the corresponding section valves compensator until the pressure level is restored to where it was previously set with all valves open.
- 3) Open and close the valve at the controller and ensure pressure remains even.
- 4) Calibrate all sections.

If the Nozzles and number of nozzles are the same in all sections you can put the same value setting on all valves.

If nozzles or number of nozzles are different, you must calibrate each valve separately.

## 3 Auto Spray-Rate Controls - MT3405F & HV4000 Models

The Auto-Spray Rate controllers perform the same function as electric controls with the added feature that once the sprayer is being operated, the Auto-Rate Controller will automatically control the output of the sprayer to match your pre-set spray rate.

To perform a pre-operation check, follow these instructions:

- a) Fit the Auto Spray-Rate control console in a convenient location in the tractor cab.
- b) Wire the power cable directly to the battery or appropriate direct-power source.
- c) Connect the tractor-end loom to the sprayer-end loom and secure the loom plugs so they cannot be damaged during use.
- d) With the correct choice of nozzles fitted to the Quantum Mist, start the PTO shaft and bring the pump up to your chosen PTO operating speed (between 400 - 540 RPM)
- e) Power-up the controller by switching ON the power switch.
- f) Push the MANUAL/START button on the face of the controller so that the word "MAN" or "MANUAL" appears on the screen.

For the HV4000, "MANUAL" will appear in the "Target Rate" box on the screen.

For the purpose of the pre-operation check, the controller will be operated in Manual mode.

### NOTE

**IMPORTANT:** Read the MT3405F or HV4000 Manual carefully, and enter the calibration values you require to achieve your target spray rate.

### WARNING

Do not have pesticides in the spraytank when checking the sprayer.

### NOTE

If independent oil supply for the fans is fitted, operate the spray pump at 400 - 540 RPM using the hydraulic flow control.



Test RUN/HOLD and LEFT/RIGHT functions.



Test the pressure UP/DOWN with console in Manual Mode (MT3405).



Adjust PRV for Pressure Control.



Read the Manual before operating the Quantum Mist.

- g) Flick the master RUN/HOLD switch to the RUN position and ensure the appropriate LEFT/RIGHT selector switches are ON.

Depending on the number of sections your sprayer has, this will be either 2 or 4 switches on the console face.

- h) With water now coming out the nozzles, press the "+" or "▲" key for 8 - 10 seconds to bring spraying pressure up to maximum.

Check the gauge during this process.

Maximum pressure should be set at 12 bar.

- i) If maximum pressure is below or above 12 bar, adjust the PRV valve on the sprayer by winding it in or out until maximum pressure (12 bar) is achieved on the gauge.

- j) Return to the Auto Spray-Rate console and check the LEFT/RIGHT and master RUN/HOLD functions.

If you have problems testing the sprayer, or if any functions are not operating correctly, consult your dealer.

For full and final operation of the Auto Spray-Rate control, read the specific MT3405F or HV4000 manual fully before operating the Quantum Mist.

## NOTE

The maximum spraying pressure will vary with different nozzles.

We recommend you re-adjust your maximum pressure if you change your nozzle selection.

## NOTE

Ensure the tank agitators are ON and operating during the pre-operation check.

## NOTE

Additional copies of the MT3405 manual can be downloaded in a PDF file format from the Internet.

For the micro-trak MT3405, log onto [www.micro-trak.com](http://www.micro-trak.com) and follow the menu.



<b>Filling</b>	<b>3.2</b>
<b>Filters</b>	<b>3.3</b>
<b>Chemical Mixing</b>	<b>3.4</b>
<b>Proceed to Spray</b>	<b>3.6</b>
• <b>Operating Pointers</b>	<b>3.6</b>
• <b>Position Spray Heads</b>	<b>3.6</b>
• <b>Adjust Nozzle Settings</b>	<b>3.7</b>
<b>Terracing Kit</b>	<b>3.8</b>
<b>Cleaning</b>	<b>3.9</b>



Open the lid & fill main tank using the basket filter.

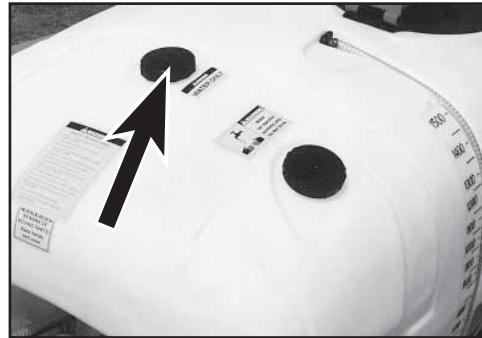

Remove the lid shown to fill the flushing tank on 2000 litre.

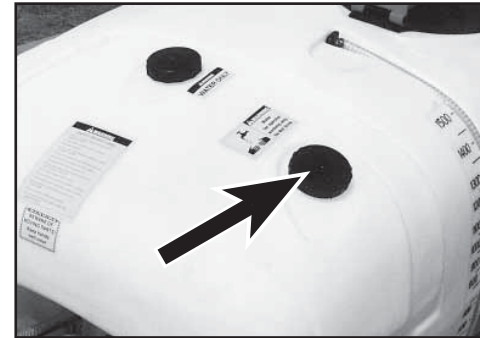

Remove the lid shown to fill the fresh water tank on 2000 litre..



CLOSE the pump suction valve before filter cleaning.

## Filling the Sprayer

The Quantum Mist features three tanks for easy operation, cleaning and safety.

### 1 Main Tank

When filling the main tank, open the spray tank lid and fill the tank with the basket filter in place.

Use fresh water (preferably rainwater), free of suspended organic matter or clay. Some chemicals are de-activated when they contact these materials.

Ensure sufficient water quantity to allow correct product blending.

3000 litre handwash tank with flush tank filling dropper hose.



### 2 Flushing Tank

Use fresh water (preferably rainwater) in the flushing tank. Unscrew the lid (shown above) and fill before spraying.

Replace the lid after filling.

**NOTE**

*The flush tank on a 3000 litre model is filled through the handwash tank.*

*Fill the flush tank via the dropper hose in the centre of the handwash tank opening. The handwash tank lid is positioned at the rear of the main tank.*

Lid configuration for 4000 litre models.



### 3 Fresh Water Tank

Use only rainwater in the flushing tank. Unscrew the lid (shown below) and fill before spraying.

Replace the lid after filling.

Remove the lid shown to fill the flush tank (4000 litre only).



## Filters

Filters will ensure that no solids enter the system to block or damage pump or nozzles.

- 1 Always ensure the basket filter is in place when filling the main tank.
- 2 All filters should be cleaned regularly, or after each spraying period.

If the filter screen is damaged, replace with a new screen.

Remove the lid shown to fill the fresh water tank (4000 litre only).





Thoroughly clean the suction filter and reassemble.

### Cleaning the Suction Filter

The suction filter should be cleaned regularly or after each spray tank has been emptied.

To clean the filter:

- 1 Completely stop all sprayer functions.
- 2 Place the pump suction valve in the closed position to shut off liquid from the main tank.
- 3 Remove the outer filter screw and bowl, and then remove the filter and thoroughly clean it.

Check the condition of O-Ring before reassembling the filter.



Clean pressure line filter regularly.

### Cleaning the Pressure Filter

The pressure line filter should be cleaned regularly or after each spray tank has been emptied.

To clean the pressure line filter:

- 1 Completely stop all sprayer functions.
- 2 Open the valve at the bottom of the filter to ensure all pressure is removed from the filter.
- 3 Remove the outer filter bowl, and then remove the filter and thoroughly clean it before re-assembling the filter.

Make sure the valve, at the bottom of the filter, is closed before operation.



Regularly clean nozzle filters (if fitted).

### Cleaning Nozzle Filters

Nozzle filters (if fitted) should be cleaned regularly to avoid nozzle blockages.

To clean the nozzle filters:

- 1 Completely stop all sprayer functions.
- 2 Remove the nozzle cap and nozzle, and then remove the filter.
- 3 If necessary remove the seal and nozzle from the cap to clean the nozzle.
- 4 Thoroughly clean the nozzle filter and nozzle before reassembling the units.



Front and rear tank agitator valves in ON position.

### Agitation

When chemical is added to the tank, the pump and agitator(s) must be operating at all times to ensure chemical does not settle in the tank.

Check to see that tank agitators are correctly adjusted.

If agitation causes too much foaming in the tank, turn off the agitator.

If chemical settles, through pump break down or other reasons, start up the sprayer after the fault has been rectified, then let the mixture in the tank agitate for a length of time to ensure thorough mixing of the chemical.

#### NOTE

*Be careful not to damage or deform the mesh or gasket while cleaning and refitting the filters and nozzle caps.*

#### NOTE

*Two agitators are fitted standard to 2000 litre tank models.*





Agitator and mixing basket valves CLOSED.



Agitator and mixing basket valves OPEN.



The pump suction valve OPEN to the main spray tank.



Agitator valves OPEN & mixing basket valve CLOSED.

## Mixing Basket

A separate chemical mixing basket is provided in the main tank to allow the operator to add and mix chemicals to the main tank while it is filling. This will save down time in spraying operations.

To operate the mixing basket:

- 1 Fill the main tank with the appropriate amount of water.
- 2 Measure the chemical required for the tank mix and place the chemical (liquid, powder or granules) into the mixing basket & close the mixer lid
- 3 Check the pump suction valve (located at the front of the sprayer) is open for sourcing liquid from the main tank.
- 4 Open agitator valves.

5. Open the mixing basket valve.
- 6 Place sprayer controls in start up position by placing the master switch in OFF position.
- 7 Engage PTO and bring the PTO speed up to 540 RPM.
- 8 Pressurise the system and operate the tank agitator by placing the master switch in ON position.
- 9 Allow the chemical to mix into the tank and close the mixing basket valve.
- 10 Keep the PTO engaged and the agitators operating while chemical is in the tank.

The mixing basket assists adding chemicals to the tank.



### CAUTION

Always follow chemical label safety instructions.

When handling chemicals always wear protective clothing ie. gloves, face mask, spray suit.

Should chemical come in contact with skin immediately rinse off with water.





Accurately calculate the amount of chemical required.



25 litre measuring bucket.

## Calculate Water & Chemical Quantities

Before spraying it is necessary to calculate the exact quantities of water and chemical needed to spray the required area of orchard or vines.

a) For chemical rates expressed in litres or kg per hectare (land area), use the formula:

**Chemicals required (litres)**

=

**Tank Volume (l) x Recommended Chemical Rate (l/ha) ÷ Spray Application Rate (l/ha)**

eg.

$$1500 \times 5 \div 400 = 18.75 \text{ litres.}$$

b) For volume of mixture required to spray the selected area, use the following formula:

**Tank Volume Required (litres)**

=

**Area (ha) x Spray Application Rate (l/ha)**

eg.

$$18.75 \times 400 = 1500 \text{ litres}$$

**Area Covered (ha)**

=

**Tank Volume (litres) ÷ Spray Application Rate (l/ha)**

eg.

$$1500 \div 400 = 3.75 \text{ hectares}$$

c) For chemical rates expressed in litres or kg per 100 litres of water (water volume), use the formula:

**Chemicals Required (litres)**

=

**Tank Volume (litres) x Recommended Chemical Rate (l/100 litres) ÷ 100**

eg.

$$1500 \times 3.0 \div 100 = 45 \text{ litres.}$$

### NOTE

*Important: Be sure to mix only enough spray mixture to cover the area required. Avoid wastage and problems of needless chemical disposal.*



Adjust height of fan on inner/outer tube.



Spin mount to move fan closer to canopy, and to allow tilt adjustment.



Adjust mount for tilt (upwards or downwards) in relation to canopy.



Adjust mount for forward/rearward fan adjustment.

## Proceed to Spray

Once the chemical mixture is in the tank, proceed to spray:

- 1 Adjust the pressure to correct operating pressure by adjusting pressure (up or down) according to instructions of the controller fitted (Refer to pages 2.20 -2.21).
- 2 Turn spray booms ON and OFF as required to spray according to the instructions of the controller fitted (Refer to pages 2.22 - 2.25 of this manual, and also the separate controller manual).

## Operating Pointers

While spraying, continually ensure that:

- 1 Engine and PTO speed are correct.
- 2 Correct operating pressure is being maintained.
- 3 Ground speed is correct and constant.
- 4 Quantum Mist spray heads are operating correctly and aimed toward the target foliage.

## Position the Spray Heads

The Quantum Mist spray heads can be adjusted individually for width & direction.

Each head should be individually adjusted to maximise coverage and penetration into the target foliage.

### a) Individual Fan Width & Height Adjustment

To individually adjust each Quantum Mist spray head width and height:

- 1 Loosen the clamp bolts.
- 2 Adjust the mast or wing uprights and fan head assemblies up or down & in or out.
- 3 Retighten the clamp bolts after adjustments have been made.
- 4 Repeat steps 1 - 3 as necessary for each fan head assembly.

### b) Directional Adjustment

To adjust individual Quantum Mist fan head direction:

- 1 Loosen the cradle-to-upright bolts and adjust the head up or down to suit.
- 2 Retighten the cradle-to-upright bolts.
- 3 Loosen the cradle-to-motor bolts and adjust the head fore or aft to suit.
- 4 Retighten the cradle-to-motor bolts.
- 5 Repeat steps 1 - 4 as necessary for each fan head.

### NOTE

Refer to the Independent Quantum Mist Report to learn about suitable spray head settings for your canopy.



*Nozzles adjusted inwards for bunch line applications.*



*Nozzles adjusted for canopy spraying.*



*Right & left booms are activated by boom switches 1 & 2. Switch 4 is used to activate the main On/Off dump valve.*

## Adjust the Nozzle Settings

Eight nozzles are standard on each Quantum Mist spray head.

Each set of nozzles on the spray heads can be adjusted to suit varying application requirements.

Two general nozzle settings are available:

- 1 Adjust both nozzles inwards to concentrate the bulk of the spray pattern into the centre of the airstream.  
(Suited to concentrated bunch line applications).
- 2 Adjust each nozzle inwards and outwards consecutively, to give the widest and most uniform spray coverage within the airstream.  
(Suited to most applications where widest coverage is wanted).

## Optional MT3405

If the optional MT3405 is fitted, the left and right booms are activated by Boom Switches 1 & 2.

Switch 4 is used to activate the main On/Off dump valve, in conjunction with the RUN/HOLD switch.

*Tighten nozzle swivel to hold setting.*





Optional terrace boom allows individual boom arm height adjustment.



Terrace boom height adjustment hydraulic rams in mid point position.



Terrace boom hydraulic manifold with CETOP3 valves.

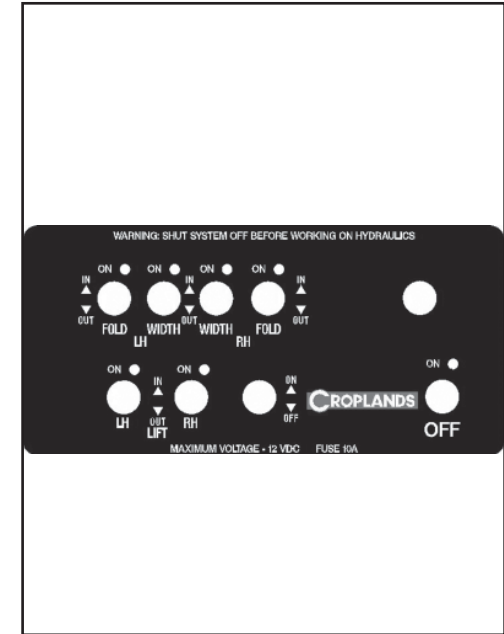

Multi-function hydraulic switch box/control panel.

## Terracing Kit (Optional)

While operating, press the Left & Right RAISE & LOWER buttons to position the height of the booms as required.



WARNING

Always wear protective gloves when cleaning filters containing toxic chemicals.

## Flushing the Quantum Mist

The Quantum Mist may be equipped with a flushing tank for cleaning the sprayer when changing chemicals, and at the end of the day.

To flush the Quantum Mist:

- 1 Ensure the site for flushing and cleaning the Quantum Mist meets with environmental and statutory regulations.
- 2 Open tank drain valve (valve located at the base of the tank) to drain remaining spray mixture from the tank.



*OPEN the Tank drain valve.*

- 3 Open the pump suction valve to the flushing tank.
- 4 Open the mixing basket valve.
- 5 Check that agitator valves are open.
- 6 Place sprayer controls in start up position according to the instructions of the controller fitted (see page ??)
- 7 Engage PTO and bring the PTO speed up to 540 RPM.

All pumped liquid is now being passed through the dump valve back into the tank. The system is not pressurised and tank agitators are not working.

- 8 Pressurise the system and operate the tank agitators.

*The pump suction valve OPEN to the flushing tank.*



*Remove & clean the filter element & components.*

- 9 Adjust pressure to desired operating pressure by adjusting pressure up or down.
- 10 Engage the hydraulics to drive the fan heads.
- 11 Turn the spray booms ON.

Fresh water now flushes through the suction line, suction filter, pump, agitator(s), pressure lines, nozzles and mixing basket.

All water comes into the tank from the flushing tank. Water remaining in the tank drains out of the tank through the drain outlet.

- 12 On completion of flushing, shut down all controls and disengage the PTO and hydraulic fan drive.
- 13 Remove and clean the suction filter and screen, and reassemble.



*Tank drain valve CLOSED.*

- 14 Adjust all valves back to operating (non-flushing) mode.
  - a) Close mixing basket valve.
  - b) Close tank drain valve.
  - c) Open pump suction valve to the main tank.
  - d) Open the agitator valves.
- 15 Wash/hose down the outside of the sprayer.

NOTE

Ensure the drained mixture is disposed of as required by law. Read chemical instructions.

NOTE

Be careful not to damage or deform the mesh or O-ring while cleaning and refitting the filters.

NOTE

Sulphur & Copper compounds lead to rapid deterioration of metal and polyethylene on your sprayer.  
It is strongly recommended that you use an exterior cleaner such as FARM MATE after every spray.  
FARM MATE is available from your Spray Shop.



Pump suction valve OPEN for liquid from the main tank.



Agitator & mixing basket valves OPEN.



Remove & clean suction filter screen and reassemble.



Fresh water tap for personal safety.

## Using Tank and Equipment Cleaners

If a cleaning agent is required (refer to chemical label), first completely flush the Quantum Mist with water as outlined in Steps 1 - 15 on page 3.9, then:

- 1 Fill the spray tank with fresh water.
- 2 Add cleaning agent into the mixer basket (use according to instructions).
- 3 Open the pump suction valve to the main tank.
- 4 Open mixing basket valve.
- 5 Open the agitator valves.
- 6 Place sprayer controls in start up position according to the instructions of the controller fitted (see the "Pre-Operation" section).

### NOTE

Ensure the drained mixture is disposed of as required by law. Read chemical instructions.

- 7 Engage PTO and bring the PTO speed up to 540 RPM.  
All pumped liquid is now being passed through the dump valve back into the tank. The system is not pressurised and tank agitators are not working.
- 8 Pressurise the system and operate the tank agitators.
- 9 Adjust pressure to desired operating pressure by adjusting pressure up or down using the toggle switch on the electric sprayer controller.
- 10 Turn the spray booms ON to put cleaner through the spray lines and nozzles.
- 11 If you require the cleaning agent to soak or stand for a period, turn the spray booms OFF and completely shut down the sprayer for a period.

- 12 When soaking is completed, start the machine following steps to flush the tank and spray lines (see page 28).
- 9 Stop flushing by switching booms off, turning controls off, disengaging the PTO and hydraulic fan drive.
- 10 Open spray tank drain valve and allow cleaning mixture to drain from the tank.
- 11 Completely flush the sprayer with fresh water as outlined on page 3.9.

## Fresh Water Tank (model dependent)

The Quantum Mist incorporates a fresh water tank on some models for personal safety when operating the unit in the field.

<b>Calibration Procedure</b>	<b>4.2</b>
<b>ALBUZ-ATR Hollow Cone Nozzle Chart</b>	<b>4.8</b>
<b>Calibration Work Sheet</b>	<b>4.9</b>



*Proper calibration considers all spraying variables.*

Applying the correct amount of chemical to a crop is only possible if:

- the sprayer is calibrated correctly.
- the sprayer is operated correctly.
- the sprayer is maintained correctly.

The variables of spray application (distance, time, working width, liquid and chemical volumes) must be measured and controlled accurately to ensure chemicals are applied at the correct rate.

The automatic spray controller measures and controls the variables of speed and flow rate to give constant application.

However proper nozzle selection, checking calibration of nozzles, speed and flow rate as well as correct mixing of chemicals must be done to ensure the accuracy and performance of the sprayer and its controller.

Accurate calibration is essential to ensure uniform application of the recommended dose of chemical to the target.

Proper calibration involves setting up the sprayer (nozzle selection, pressure, speed), calculating chemical and water rates and measuring the performance of the sprayer itself. Only then can you be totally confident in applying chemical correctly.

## Fully Automatic Spray Controller (Optional)

The fully automatic spray controller maintains the application rate (set by the operator) when operated in Auto position.

The controller monitors speed of travel (speed sensor) and flow rate (flow meter) and automatically adjusts flow rate (via a servo valve) to maintain correct application rate irrespective of speed variations within the limits of the nozzles used.

## IMPORTANT:

- 1 It should be remembered that the spray controller does not eliminate the necessity to measure and check the accuracy of nozzle spray patterns and outputs. These must be checked regularly to ensure correct and uniform application rates because nozzles wear with use.
- 2 Flow meters used by the controller also needs to be checked and calibrated on a regular basis.

On the following page, you will see how to maintain and check your Rapid-check flowmeter. It is recommended you do this regularly during the spraying season.

See the Controller Operator's Manual for detailed information and calibrating procedures specific to you spray controller.



*Rapid Check Flowmeter (optional).*

## Calibration Procedure

For accurate spray rate application, follow this calibration procedure:

### Step 1

### Ensure Equipment Is In Good Working Order.

Tank, pump, boom, filters and nozzles must be clean, free of leakages and functioning properly.

Follow the pre-operation checklist, maintenance and operating instructions in this manual.

Install, calibrate and operate the spray controller according to the spray controller Installation/Operators Manual.



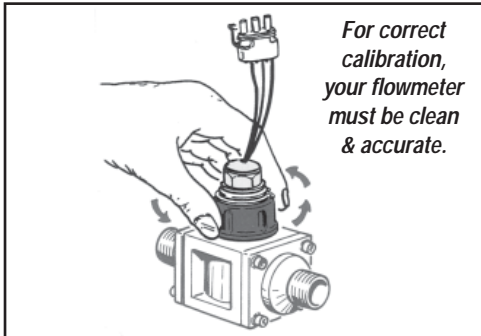

*For correct calibration, your flowmeter must be clean & accurate.*

*Unscrew the the Rapid Check assembly.*

### Daily Check & Maintenance of Flowmeter (optional)

This is to be performed every day after work is finished:

- 1 Unscrew the assembly that holds the Rapid Check unit in the body.
- 2 Remove the Rapid Check unit from the body.

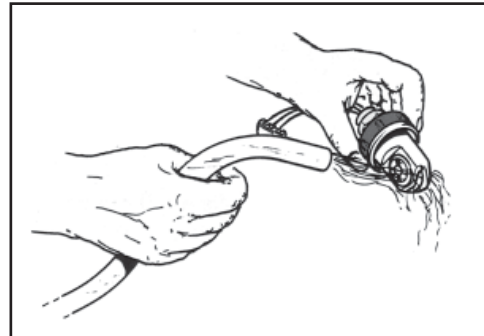

*Wash any impurities out of the removable turbine unit.*

- 3 Use clean water to wash any impurities out of the removable turbine unit.
- 4 Use compressed air to verify that the turbine unit rotates freely (maximum air pressure 1 BAR [15 psi]).

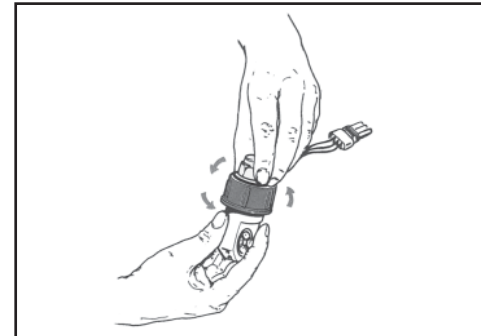

*Unscrew the sensor.*

### Every 50 Hours

Carry out the following procedure after every 50 hours of operation:

- 1 Unscrew the sensor.
- 2 Separate the sensor from the Rapid Check unit.

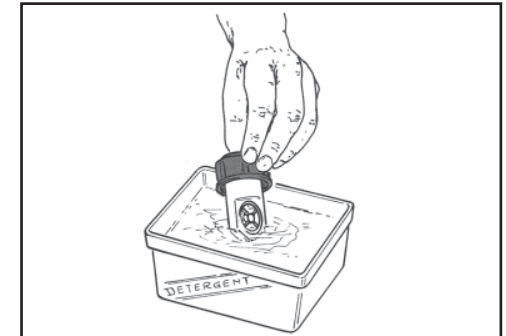

*Place the Rapid Check unit in a detergent bath.*

- 3 Place the Rapid Check unit in a detergent bath for a few hours.
- 4 Remove the Rapid Check unit from detergent bath.

Use compressed air to verify that the turbine unit rotates freely (maximum air pressure 1 BAR [15 psi]).

If necessary, replace the Rapid Check unit with a new one.

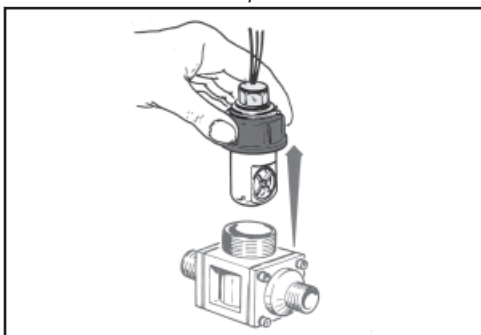

*Remove the Rapid Check unit.*

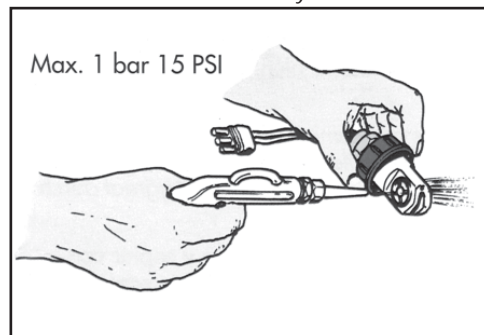

*Use compressed air to check that the turbine unit rotates freely.*

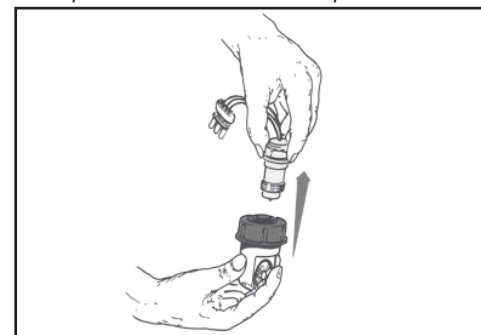

*Separate the sensor from the Rapid Check unit.*

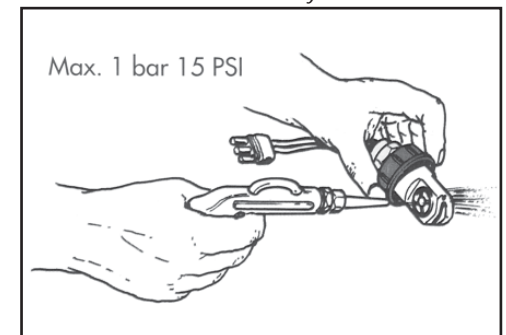

*Use compressed air to check that the turbine unit rotates freely.*

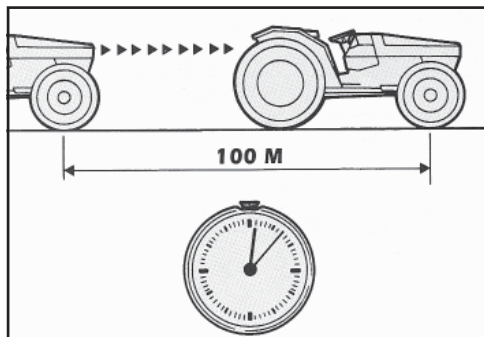

Determine actual speed of travel.



Determine spraying volume required.



Buyers Guide - courtesy of TeeJet.



Fan head nozzles can be turned On or Off.

## Step 2 Determine Actual Speed of Travel

It is essential to use actual speed of travel when calibrating application rates.

- Half fill the sprayer tank with water and mark out a test strip of 100 metres (simulating spraying conditions).
- Set the sprayer operating and record the time taken to travel 100 metres at your required spraying speed.
- Calculate the actual speed of travel using the formula:

$$\text{km/hr} = \frac{\text{Distance (m)} \times 3.6}{\text{Time (sec)}}$$

eg.  $100 \times 3.6 \div 100 = 3.6 \text{ km/hr}$

An alternative formula is:

$$\text{km/hr} = \frac{\text{Metres travelled in 1 minute}}{60}$$

## Step 3 Determine Spraying Volume Required

It is essential to determine the **liquid volume per hectare** required to effectively spray a crop without overspraying or underspraying.

The term “litres per hectare” must be related to foliage and not just to land area.

The amount of liquid needed to effectively spray any given crop will vary greatly with:

- The type of crop,
- Row spacing,
- Width of canopy,
- Height of canopy.
- Stage of growth,
- Density of foliage,
- Type of leaf surface,
- Type of fruit (single or bunched)
- Type of sprayer used.

## Step 4 Determine Sprayer Configuration

Once the volume of required spray volume per hectare is established, the next step in calibrating your sprayer is to determine:

- The **number of row(s)** to be sprayed in one pass, and
- The **total number of nozzles** to be used on the sprayer.

Both these factors can vary with the type of sprayer used and other factors mentioned under step 3 (on this page).

### Example 1

A Quantum Mist to spray apples – using six spray heads, each with 8 nozzles (total 48 nozzles) to spray one row per pass.

### Example 2

A Quantum Mist to spray Citrus – using eight spray heads, each with 8 nozzles (total 64 nozzles) to spray one row per pass.

### NOTE

*Always use Actual Speed of Travel for speed in the calibration formula.*

### NOTE

*Use your own experience or a registered rate calibration consultant to determine effective application rates in litres per hectare.*



Select and fit nozzles to the spray heads.



Measure how much water is required to refill the tank.

## Step 5 Determine & Select Nozzles

Knowing actual travel speed, application rate required, number of rows to be sprayed in one pass and total number of nozzles to be used, we can determine the nozzles required for the sprayer. Use the formula below:

$$\frac{\text{Litres/Minute/Nozzle}}{=} \frac{\text{Litres/Ha} \times \text{Km/hr} \div 600 \div \text{Total Number of Nozzles Used} \times \text{Row Spacing (m)} \times \text{Number of Rows in One Pass}}$$

### Example 1

$$500 \text{ (l/ha)} \times 3.9 \text{ km/hr} \div 600 \div 32 \text{ (nozzles)} \times 3 \text{ m (row spacing)} = 0.122 \text{ litres/minute/nozzle}$$

### CAUTION

Do not use worn nozzles to set the pressure setting and nozzle rates, otherwise inaccurate calibration will occur.

### Example 2

$$400 \text{ (l/ha)} \times 3.9 \text{ km/hr} \div 600 \div 64 \text{ (nozzles)} \times 3 \text{ m (row spacing)} \times 2 \text{ (rows/pass)} = 0.244 \text{ litres/minute/nozzle}$$

Once the the flow rate per nozzle is known, it is necessary to select an appropriate nozzle size from the relevant nozzle chart(s) (see pages 4.8).

### Example 2, Nozzle Selection

Using the TXB-VK Nozzle chart on page 4.8, the closest matches for 0.244 litres/minute/nozzle are:

- TXB800050VK giving 0.223 l/min, operating at 4 Bar (60 psi).

This nozzle with a marginal increase in pressure will meet our requirements.

### NOTE

The flow rate of each nozzle is dependent on the nozzle size and operating pressure.

## Step 6 Fit & Test Selected Nozzles

Now, the most important calibration is to test for the **actual litres per hectare** achieved through your sprayer.

Use the following method to fit and test the selected nozzles:

- Fit selected nozzles to the sprayer.
- Fill your spray tank to overflowing & set the specified pump pressure and operate the sprayer for a short period to make sure all lines are full and nozzles are working properly (no blockages, leaks etc).
- Stop the sprayer and top up the tank with water to overflowing again.

### NOTE

Remember when selecting nozzle outputs that higher pressures and wider spray angles usually give finer droplet sizes than lower pressures and narrower spray angles.

- Operate the sprayer in the stationary position at the required pressure for approximately one minute.

- Measure how much water is required to refill the tank to the brim.

Now, divide the volume measured by the time taken (minutes).

$$\frac{\text{Output/min (l/min)}}{=} \frac{\text{Output (litres)} \div \text{Time (minutes)}}$$

### Example 1

$$9.75 \text{ litres} \div 1.25 \text{ minutes} = 7.8 \text{ litres/min.}$$

### Example 2

$$19.5 \text{ litres} \div 1.25 \text{ minutes} = 15.6 \text{ litres/min.}$$

### WARNING

Do not use mixed pesticides for testing. Use only clean water. Use of pesticides when testing is hazardous to your health.



+/- keys (Optional Auto Rate Controller).

## Step 7 Calculate the Actual Application Rate

Actual application rate is the objective of setting up and calibrating your sprayer.

To calculate actual application rate (litres per hectare), use the following formula:

$$\text{Application Rate (l/ha)} =$$

$$\frac{\text{Total Sprayer Output (l/min)} \times 600 \div \text{Speed (Km/hr)} \div \text{Row Spacing (m)} \div \text{Number Rows in One Pass}}{}$$

### Example 1

$$7.8 \text{ (l/min)} \times 600 \div 3.9 \text{ km/hr} \div 3\text{m (row spacing)} \div 2 \text{ (rows/pass)} = 200 \text{ litres/ha.}$$

### Example 2

$$15.6 \text{ (l/min)} \times 600 \div 3.9 \text{ km/hr} \div 3\text{m (row spacing)} \div 2 \text{ (rows/pass)} = 400 \text{ litres/ha.}$$

## Step 8 If the Tested Rate is Unsatisfactory

If your tested application rate does not meet your requirements, your options are:

**a) In Auto mode** - if application rate is not being achieved:

- i) Operating pressure will climb if nozzles are too small or blocked or speed is too fast. Likewise, if your pressure filter is blocked (even partially), you may experience excessive pressure at the pump.

Make adjustments accordingly.

- ii) Operating pressure will fall if nozzles are too large or speed is too slow. Make adjustments accordingly.

### CAUTION

*Do not use worn nozzles to set the pressure setting and nozzle rates, otherwise inaccurate calibration will occur.*

**b) In Manual mode** - the Controller application rate can be altered by:

- i) Adjusting pressure up or down to increase or decrease rate of application (use +/- keys).
- ii) Adjusting spraying speed up or down to decrease or increase rate of application.
- iii) Changing to a different nozzle capacity.

Repeat necessary testing procedures and calculation of application rate if adjustments or changes are made.

### NOTE

*The flow rate of each nozzle is dependent on the nozzle size and operating pressure.*

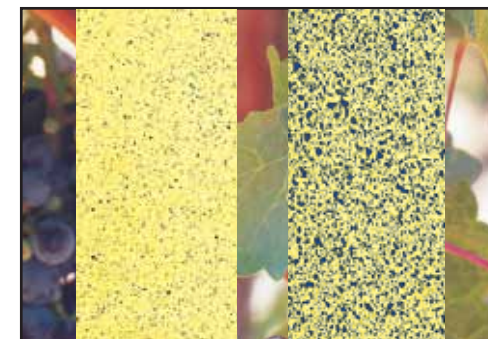

Samples of water sensitive paper tests.

## Step 9 Field Check Coverage

Operate your sprayer in the required orchard or vineyard to check the actual spray coverage achieved on foliage.

This is important because it is the only real measure you have of actual coverage and effective penetration of your sprayer.

Coverage checks can be done using:

- A fluorescent dye system - often available through chemical and spray equipment suppliers.
  - Water or oil sensitive papers available through chemical and spray equipment suppliers.
- Ensure cards are strategically placed on both upper and lower surfaces.

It is recommended to test the unit using water only as a test run, and again when applying your chemical mixture.



### Step 10 Add The Correct Amount Of Chemical To The Tank

a) For land area rates (litres or kg per hectare), use the following formula:

$$\text{Chemical Required (litres)} =$$

$$\frac{\text{Tank Volume (litres)} \times \text{Recommended Chemical Rate (l/ha)}}{\text{Spray Application Rate (l/ha)}}$$

eg,  $\frac{[2000 \times 2.0]}{50}$   
= 80 litres

b) If chemical recommendation is given in water volume rates use the following formula:

$$\text{Chemical Required (litres)} =$$

$$\frac{\text{Tank Volume (litres)} \times \text{Recommended Chemical Rate (l/100 litres)}}{100}$$

eg,  $\frac{[2000 \times 4]}{100}$   
= 80 litres

c) For tank volume required, use the formula:

$$\text{Tank Volume Required (litres)} =$$

$$\text{Area (ha)} \times \text{Spray Application Rate (l/ha)}$$

eg,  $20 \times 50$   
= 1000 litres

### Step 11 Adjust Fans

Fan angle and height can drastically affect spray coverage.

Contact your dealer for advice and information on optimum setup.

(Adjustment steps are shown on Page 3.6)

### Step 12 Record All Data For Future Reference

Record all your calibration data on the work sheets given at the end of this section.

Photocopy the work sheets to obtain the number of work sheets required.

#### NOTE

*Mix only the amount required. Avoid wastage and the problem of needless chemical disposal.*

#### NOTE

*All nozzles have a pressure and flow rate range to achieve the best results. Ensure you have selected the nozzle which best suits your application to avoid any problems.*

#### NOTE

*Full instructions of controller operation are contained in your separate Controller Manual.*



## Features:

- Angle of 80° at 5 bar
- Easy dismantling for cleaning
- Hollow cone nozzle producing fin droplets
- Albus durable pink ceramic allows precision high pressure spraying
- Polished ceramics ensure perfect sealing and precise flow rate.

## Applications:

- For fungicides and insecticides
- Recommended for orchards and vineyards.

ALBUZ NOZZLE	PART NUMBER	MESH	5 Bar	6 Bar	7 Bar	8 Bar	9 Bar	10 Bar	11 Bar	12 Bar
WHITE	AZ-ATR-WE-80C	100	0.27	0.29	0.32	0.34	0.36	0.38	0.39	0.41
LILAC	AZ-ATR-LC-80C	50	0.36	0.39	0.42	0.45	0.48	0.50	0.52	0.55
<b>CURRENT STANDARD</b>	BROWN	AZ-ATR-BN-80C	50	0.48	0.52	0.56	0.60	0.64	0.67	0.70
<b>CURRENT STANDARD</b>	YELLOW	AZ-ATR-YW-80C	50	0.73	0.80	0.86	0.92	0.97	1.03	1.07
	ORANGE	AZ-ATR-OE-80C	50	0.99	1.08	1.17	1.24	1.32	1.39	1.45
	RED	AZ-ATR-RD-80C	50	1.38	1.51	1.62	1.73	1.83	1.92	2.01
	GREY	AZ-ATR-GY-80C	50	1.50	1.63	1.76	1.87	1.98	2.08	2.17
	GREEN	AZ-ATR-GN-80C	50	1.78	1.94	2.09	2.22	2.35	2.47	2.58
	BLACK	AZ-ATR-BK-80C	50	2.00	2.18	2.35	2.50	2.64	2.78	2.90
	BLUE	AZ-ATR-BE-80C	50	2.45	2.67	2.87	3.06	3.24	3.40	3.56

COMPARITIVE COMMENT	ALBUZ NOZZLE	TXB NOZZLE	MESH	5 Bar	6 Bar	7 Bar	8 Bar	9 Bar	10 Bar	11 Bar	12 Bar
Slightly Lower Output	WHITE	TXB800050VK	100	0.25	0.27	0.28	0.30	0.32	0.33	0.35	0.36
Slightly Lower Output	LILAC	TXB800067VK	50	0.33	0.36	0.39	0.41	0.43	0.45	0.47	0.49
Slightly Higher Output	BROWN	TXB8001VK	50	0.50	0.54	0.58	0.62	0.65	0.68	0.71	0.74
Slightly Lower Output	YELLOW	TXB80015VK	50	0.75	0.82	0.89	0.94	1.00	1.05	1.10	1.15
Slightly Higher Output	ORANGE	TXB8002VK	50	1.01	1.10	1.18	1.26	1.33	1.40	1.47	1.53
Substantially Lower Output	RED	TXB8003VK	50	1.53	1.67	1.80	1.93	2.04	2.15	2.25	2.35
Slightly Lower Output	GREY	TXB8003VK	50	1.53	1.67	1.80	1.93	2.04	2.15	2.25	2.35
Substantially Higher Output	GREEN	TXB8003VK	50	1.53	1.67	1.80	1.93	2.04	2.15	2.25	2.35
Slightly Higher Output	BLACK	TXB8004VK	50	2.03	2.23	2.40	2.57	2.72	2.87	3.01	3.14
Substantially Higher Output	BLUE	TXB8004VK	50	2.03	2.23	2.40	2.57	2.72	2.87	3.01	3.14

**Step 1 Check the Sprayer is in Good Working Order**

**Step 2 Determine Actual Speed of Travel**

Measure and mark a straight path of 100 metres (or more) of travelling conditions similar to the orchard or vineyard you are going to spray.

Half fill the spray tank & record the time (in seconds) to travel the measured distance.

Make sure that the tractor is travelling at spraying speed when you pass the start and finish marks and ensure the the fan and pump are at operational speed.

If you have a hectare metre or automatic controller you need to check the speed calibration of the contoller.

Tractor model	
Gear	
Range	
Dual power	
Engine RPM	
Speed in Km/hr	

**Kilometres per Hour**  
=  
**Distance traveled (m) x 3.6**

**Step 3 Determine Spraying Volume Required**

It is essential to determine the liquid volume per hectare required to effectively spray a crop without overspraying or underspraying.

Use your own experience or a registered rate calibration consultant to determine effective volume in litres per hectare.

..... litres/ha

**Step 4 Determine Sprayer Configuration**

- **Number of row(s)** to be sprayed in one pass .....
- **Total number of nozzles** to be used .....

**Step 5 Determine & Select Nozzles**

Determine nozzle flow rate required:

**Litres/Minute/Nozzle**  
=  
**Litres/Ha x Km/hr ÷ 600 ÷ Total Number of Nozzles Used x Row Spacing (m) x Number of Rows in One Pass**

eg.  
..... x ..... ÷ 600 ÷ ..... x ..... x .....  
= ..... litres/minute/nozzle.

Once the flow rate per nozzle is known, select an appropriate nozzle size from the nozzle charts [see pages 4.9 -4.11].

Nozzle Selection: .....

**Step 6 Fit & Test Selected Nozzles**

The most important calibration is to test for actual litres per hectare.

Fill your spray tank to overflowing and run the sprayer for one minute, at the above operating settings, and record the total litres per minute used.

**Output/min (l/min)**  
=  
**Output (litres) ÷ Time (minutes)**  
..... ÷ .....  
= ..... litres/min.

**Step 7 Calculate the Actual Application Rate**

To calculate actual application rate (litres per hectare), use the following formula:

**Application Rate (l/ha)**  
=  
**Total Sprayer Output (l/min) x 600 ÷ Speed (Km/hr) ÷ Row Spacing (m) ÷ Number Rows in One Pass**  
..... x 600 ÷ ..... ÷ ..... ÷ .....  
= ..... litres/ha.

**Record your data:**

Farm location	
Crop to be sprayed	
Canopy width (m)	
Canopy Height (m)	
Spray Volume litres/ha	
No. Rows in one pass	
No. of nozzles used	
Litres/minute/nozzle	
Nozzle pressure	
Nozzle type	
Nozzle size & colour	
Tested Output in l/min	
Actual Litres/Hectare	

**Note:** If your sprayer has a flow meter fitted, you should calibrate it regularly. The calibration setting on the tag is a factory setting only and needs to be regularly checked - taking into consideration changes in density and/or viscosity of the product to be sprayed.

**Step 1 Check the Sprayer is in Good Working Order**

**Step 2 Determine Actual Speed of Travel**

Measure and mark a straight path of 100 metres (or more) of travelling conditions similar to the orchard or vineyard you are going to spray.

Half fill the spray tank & record the time (in seconds) to travel the measured distance.

Make sure that the tractor is travelling at spraying speed when you pass the start and finish marks and ensure the the fan and pump are at operational speed.

If you have a hectare metre or automatic controller you need to check the speed calibration of the contoller.

Tractor model	
Gear	
Range	
Dual power	
Engine RPM	
Speed in Km/hr	

$$\text{Kilometres per Hour} = \text{Distance traveled (m)} \times 3.6$$

**Step 3 Determine Spraying Volume Required**

It is essential to determine the liquid volume per hectare required to effectively spray a crop without overspraying or underspraying.

Use your own experience or a registered rate calibration consultant to determine effective volume in litres per hectare.

..... litres/ha

**Step 4 Determine Sprayer Configuration**

- **Number of row(s)** to be sprayed in one pass .....
- **Total number of nozzles** to be used .....

**Step 5 Determine & Select Nozzles**

Determine nozzle flow rate required:

$$\text{Litres/Minute/Nozzle} = \frac{\text{Litres/Ha} \times \text{Km/hr} \div 600 \div \text{Total Number of Nozzles Used} \times \text{Row Spacing (m)} \times \text{Number of Rows in One Pass}}$$

eg. .... x .... ÷ 600 ÷ .... x .... x ....  
= ..... litres/minute/nozzle.

Once the flow rate per nozzle is known, select an appropriate nozzle size from the nozzle charts [see pages 4.9 -4.11].

Nozzle Selection: .....

**Step 6 Fit & Test Selected Nozzles**

The most important calibration is to test for actual litres per hectare.

Fill your spray tank to overflowing and run the sprayer for one minute, at the above operating settings, and record the total litres per minute used.

**Output/min (l/min)**

=

**Output (litres) ÷ Time (minutes)**

..... ÷ .....  
= ..... litres/min.

**Step 7 Calculate the Actual Application Rate**

To calculate actual application rate (litres per hectare), use the following formula:

$$\text{Application Rate (l/ha)} = \frac{\text{Total Sprayer Output (l/min)} \times 600 \div \text{Speed (Km/hr)} \div \text{Row Spacing (m)} \div \text{Number Rows in One Pass}}$$

..... x 600 ÷ ..... ÷ ..... ÷ .....  
= ..... litres/ha.

**Record your data:**

Farm location	
Crop to be sprayed	
Canopy width (m)	
Canopy Height (m)	
Spray Volume litres/ha	
No. Rows in one pass	
No. of nozzles used	
Litres/minute/nozzle	
Nozzle pressure	
Nozzle type	
Nozzle size & colour	
Tested Output in l/min	
Actual Litres/Hectare	

**Note:** If your sprayer has a flow meter fitted, you should calibrate it regularly. The calibration setting on the tag is a factory setting only and needs to be regularly checked - taking into consideration changes in density and/or viscosity of the product to be sprayed.



**Step 1 Check the Sprayer is in Good Working Order**

---

**Step 2 Determine Actual Speed of Travel**

Measure and mark a straight path of 100 metres (or more) of travelling conditions similar to the orchard or vineyard you are going to spray.

Half fill the spray tank & record the time (in seconds) to travel the measured distance.

Make sure that the tractor is travelling at spraying speed when you pass the start and finish marks and ensure the the fan and pump are at operational speed.

If you have a hectare metre or automatic controller you need to check the speed calibration of the contoller.

Tractor model	
Gear	
Range	
Dual power	
Engine RPM	
Speed in Km/hr	

**Kilometres per Hour**  
= **Distance traveled (m) x 3.6**

**Step 3 Determine Spraying Volume Required**

It is essential to determine the liquid volume per hectare required to effectively spray a crop without overspraying or underspraying.

Use your own experience or a registered rate calibration consultant to determine effective volume in litres per hectare.

..... litres/ha

---

**Step 4 Determine Sprayer Configuration**

- **Number of row(s)** to be sprayed in one pass .....
- **Total number of nozzles** to be used .....

---

**Step 5 Determine & Select Nozzles**

Determine nozzle flow rate required:

**Litres/Minute/Nozzle**  
= **Litres/Ha x Km/hr ÷ 600 ÷ Total Number of Nozzles Used x Row Spacing (m) x Number of Rows in One Pass**

eg.  
..... x ..... ÷ 600 ÷ ..... x ..... x .....  
= ..... litres/minute/nozzle.

Once the flow rate per nozzle is known, select an appropriate nozzle size from the nozzle charts [see pages 4.9 -4.11].

Nozzle Selection: .....

**Step 6 Fit & Test Selected Nozzles**

The most important calibration is to test for actual litres per hectare.

Fill your spray tank to overflowing and run the sprayer for one minute, at the above operating settings, and record the total litres per minute used.

**Output/min (l/min)**  
=  
**Output (litres) ÷ Time (minutes)**  
..... ÷ .....  
= ..... litres/min.

---

**Step 7 Calculate the Actual Application Rate**

To calculate actual application rate (litres per hectare), use the following formula:

**Application Rate (l/ha)**  
=  
**Total Sprayer Output (l/min) x 600 ÷ Speed (Km/hr) ÷ Row Spacing (m) ÷ Number Rows in One Pass**

..... x 600 ÷ ..... ÷ ..... ÷ .....  
= ..... litres/ha.

**Record your data:**

Farm location	
Crop to be sprayed	
Canopy width (m)	
Canopy Height (m)	
Spray Volume litres/ha	
No. Rows in one pass	
No. of nozzles used	
Litres/minute/nozzle	
Nozzle pressure	
Nozzle type	
Nozzle size & colour	
Tested Output in l/min	
Actual Litres/Hectare	

**Note:** If your sprayer has a flow meter fitted, you should calibrate it regularly. The calibration setting on the tag is a factory setting only and needs to be regularly checked - taking into consideration changes in density and/or viscosity of the product to be sprayed.

**Step 1 Check the Sprayer is in Good Working Order**

**Step 2 Determine Actual Speed of Travel**

Measure and mark a straight path of 100 metres (or more) of travelling conditions similar to the orchard or vineyard you are going to spray.

Half fill the spray tank & record the time (in seconds) to travel the measured distance.

Make sure that the tractor is travelling at spraying speed when you pass the start and finish marks and ensure the the fan and pump are at operational speed.

If you have a hectare metre or automatic controller you need to check the speed calibration of the contoller.

Tractor model	
Gear	
Range	
Dual power	
Engine RPM	
Speed in Km/hr	

$$\text{Kilometres per Hour} = \text{Distance traveled (m)} \times 3.6$$

**Step 3 Determine Spraying Volume Required**

It is essential to determine the liquid volume per hectare required to effectively spray a crop without overspraying or underspraying.

Use your own experience or a registered rate calibration consultant to determine effective volume in litres per hectare.

..... litres/ha

**Step 4 Determine Sprayer Configuration**

- **Number of row(s)** to be sprayed in one pass .....
- **Total number of nozzles** to be used .....

**Step 5 Determine & Select Nozzles**

Determine nozzle flow rate required:

$$\text{Litres/Minute/Nozzle} = \frac{\text{Litres/Ha} \times \text{Km/hr} \div 600 \div \text{Total Number of Nozzles Used} \times \text{Row Spacing (m)} \times \text{Number of Rows in One Pass}}$$

eg. .... x .... ÷ 600 ÷ .... x .... x ....  
= ..... litres/minute/nozzle.

Once the flow rate per nozzle is known, select an appropriate nozzle size from the nozzle charts [see pages 4.9 -4.11].

Nozzle Selection: .....

**Step 6 Fit & Test Selected Nozzles**

The most important calibration is to test for actual litres per hectare.

Fill your spray tank to overflowing and run the sprayer for one minute, at the above operating settings, and record the total litres per minute used.

**Output/min (l/min)**

=

**Output (litres) ÷ Time (minutes)**

..... ÷ .....  
= ..... litres/min.

**Step 7 Calculate the Actual Application Rate**

To calculate actual application rate (litres per hectare), use the following formula:

$$\text{Application Rate (l/ha)} = \frac{\text{Total Sprayer Output (l/min)} \times 600 \div \text{Speed (Km/hr)} \div \text{Row Spacing (m)} \div \text{Number Rows in One Pass}}$$

..... x 600 ÷ ..... ÷ ..... ÷ .....  
= ..... litres/ha.

**Record your data:**

Farm location	
Crop to be sprayed	
Canopy width (m)	
Canopy Height (m)	
Spray Volume litres/ha	
No. Rows in one pass	
No. of nozzles used	
Litres/minute/nozzle	
Nozzle pressure	
Nozzle type	
Nozzle size & colour	
Tested Output in l/min	
Actual Litres/Hectare	

**Note:** If your sprayer has a flow meter fitted, you should calibrate it regularly. The calibration setting on the tag is a factory setting only and needs to be regularly checked - taking into consideration changes in density and/or viscosity of the product to be sprayed.

<b>Greasing &amp; Service Procedures</b>	<b>5.2</b>
<b>Grease Points</b>	<b>5.3</b>
<b>Diaphragm Pumps</b>	<b>5.4</b>
<b>Filters</b>	<b>5.6</b>
<b>General Maintenance</b>	<b>5.7</b>
<b>Assembly of the QM500 Spray Head</b>	<b>5.9</b>

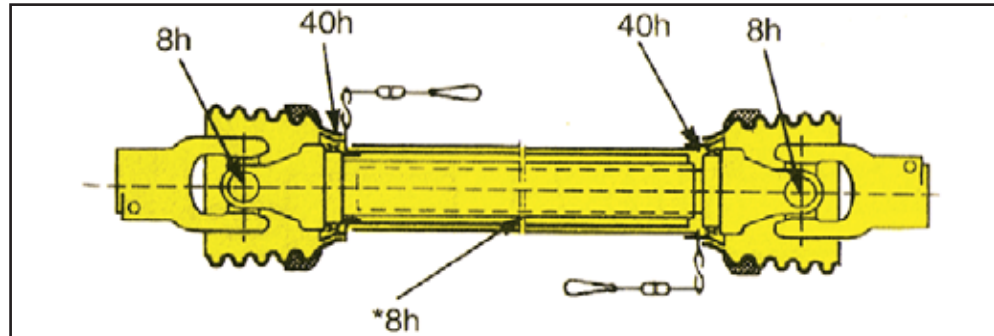

Grease the PTO shaft as shown. \* Pull shaft apart - apply grease to the inside of the outer telescopic profile.



Remove & soak nozzles in Farm Mate cleaner.

## Greasing & Service Procedures

- 1 Clean suction line filter with each tank load.
- 2 Clean pressure line filter.
- 3 Check nozzle filters.
- 4 Check tyre pressure (350kPa), and check wheel nuts.
- 5 Clean Rapid-check flowmeter (refer to page 4.3), if fitted.

- 6 Grease tractor to sprayer PTO universal joints every 8 hours.  
Grease lightly until grease becomes firm in seals. Over greasing will break seals and allow dust and moisture to penetrate - increasing wear.
- 7 Grease PTO inner tubes every 8 hours.  
To lubricate the inner tube, slide PTO shaft apart, clean the telescopic tubes, grease and reassemble.
- 8 Grease the PTO covers every 20 hours.
- 9 Ensure safety covers and safety chains are in place and in good working order

- 10 Grease self steer drawbar every 20 hours.
- 11 Check pump air chamber pressure on a regular basis. As a general guideline it should be 10%-20% of operating pressure (70-100 kPa [10-15 psi]). Refer to page 2.19 for more information.
- 12 To ensure trouble free spraying, flush the sprayer with fresh water thoroughly each day, and before changing chemicals.  
Dispose of tank wash according to chemical manufacturers instructions.
- 13 Grease all boom joints, height adjuster points and other grease points (refer diagram on page 5.3).

## Every 200 Hours

- 1 Lubricate quick release lock pins on PTO shaft.
- 2 Re-pack wheel bearings with grease.
- 3 Grease all tank lid seals with vaseline.
- 4 Check to ensure agitators have not become blocked with sulphur/chemicals.
- 5 Inspect all hydraulic lines for wear points.
- 6 Check pump mounts.
- 7 Check fan RPM and oil pressure at test port.
- 8 Soak all nozzles in FARM MATE cleaner, and thoroughly flush/clean sprayer with tank cleaner.

### NOTE

Ensure the sliding inner tubes of the PTO are greased every 8 hours (working around the clock equals 3 times/day), especially when doing a lot of tight turning.



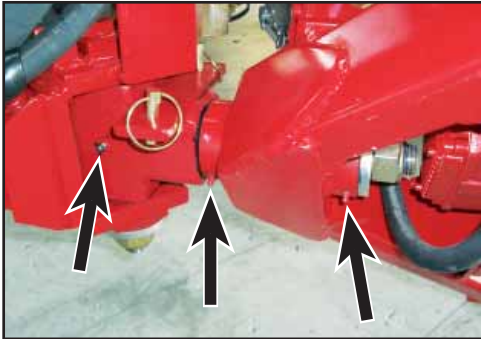

*Grease all swivel drawbar grease points.*

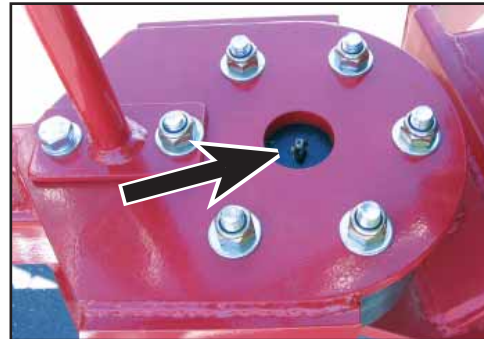

*Grease the self steer ball assembly regularly.*



*Grease wheel hubs.*

## Grease Points

- 1 Swivel eye on drawbar - see page 2.10.
- 2 Wheel hubs, if fitted with grease nipples.
- 3 PTO shaft - all crosses (knuckles), both ends and sliding tubes. Refer to page 5.2 for frequency.



AR185 - 180l/min diaphragm pump.

## Diaphragm Pump Maintenance

Annovi & Reverberi (A&R) pumps are of the piston-diaphragm type. All parts in contact with the spray liquid, which are subject to corrosion, are protected, making them ideal for spraying.

### Daily Before Starting the Pump

- 1 Check that oil is visible in sight glass (half way up) and top up if necessary with good clean motor oil 20W/30 or 20W/40.
- 2 Clean all sprayer filters. Blocked or semi blocked filters place extra stress on diaphragms.
- 3 Start with zero pressure and the pump will self prime immediately and clear air locks in suction line.

### Daily after Use

- 1 Flush pump with clean water.
- 2 Drain filters and clean. A high percentage of pump failures are due to blocked filters.

### Every 50 Hours

Check surge chamber pressure and adjust as follows:

- Air pressure 70-100kPa (10- 15psi) [Should be 10-20% of operating pressure].

Vibration of the delivery hose usually indicates that the air pressure in the surge chamber is incorrect.

The main cause of surge chamber diaphragm fracture is low pressure in this chamber.

Surge chamber pressure can be checked with an ordinary tyre gauge.

The above pressure range is a guide to the correct pressure.

However, if difficulties recur, adjust the pressure until an even flow is obtained from the pump (no pulsing of liquid at operating RPM). The pressure is best increased with a bicycle pump, hand pump or foot pump.

### Every 250 hours or Every Season - Whichever Comes Sooner

- 1 Change oil and refill with 20W/30 oil. Attention should be made to remove trapped air behind the diaphragms by rocking from side to side as instructed. It is also good practise to run the pump for 10 minutes without pressure, and then, top up with oil before working the pump.
- 2 When changing the pump oil, check diaphragms and replace them if they are showing signs of wear. Diaphragm valves should be replaced every 400 hours regardless of wear. This is normally a pre-season maintenance procedure which can be done easily as no special tools are required. You can avoid unnecessary down time in spraying seasons by carrying out the proper maintenance.
- 3 Also check inlet and outlet valves and replace if worn. Worn valves not only reduce the output of the pump, but may reduce the life of the diaphragms.



#### CAUTION

*Running a diaphragm pump faster than specified will not improve performance, but will damage and wear out moving parts.*

*Warranty will be made void by speeds in excess of those indicated on the pump name plate.*

## Excessive Diaphragm Failure

If you have excessive diaphragm failure check the following points. These will cause failure of diaphragms due to added stress or chemical attack.

- 1 **Most Important** - Pump not being flushed out daily with clean water after use.
- 2 Oil level too low allowing air between piston and diaphragm.
- 3 Air leaks in suction line.
- 4 Restricted suction line.
- 5 Restriction through suction filter.
- 6 Not cleaning suction filter regularly.
- 7 Worn suction and discharge valves.
- 8 Bypass line too small to carry full capacity of pump.
- 9 In cold climates - frozen suction/ discharge lines or water remaining in the pump after flushing.
- 10 Incorrect air setting or no air in air chamber.
- 11 Agitator excessively restricting bypass from pump.
- 12 Diaphragm material construction incorrect for chemical or solution being pumped.
- 13 Chemicals containing toluene or other aggressive solvents may require viton diaphragms - particularly if the pump is not properly flushed after use.

## Pre-Season Servicing

For thorough pre-season servicing - check all aspects of the Quantum Mist and its operating components as outlined in the pre-delivery check list on page 1.7.

## Pump Storage and Corrosion Protection

### 1 Warm Climates

If you operate in a warm climate with no chance of frost in the winter, you will not have any problems with frost damage.

If you are storing your sprayer between seasons, ensure your pump has been thoroughly flushed with clean water. A good idea is to run a mixture of 1% solution of summer mineral spraying oil through the pump and plumbing system. Summer spraying oil is water-soluble oil such as DC-Tron. This will coat and protect all internal pump parts. Ensure this mixture is flushed out before spraying commences in the new season.

### 2 Cold Climates

For prolonged storage, an anti-freeze mixture can be flushed through the pump. Ensure this is thoroughly flushed out prior to the commencement of spraying again.

If the pump is being stored overnight and a risk of freezing is imminent, drain all liquid from the pump and lines, including boom lines.



The pump suction valve **CLOSED** to the main tank.



Remove the outer filter screw and bowl.



Reassemble and tighten the outer filter screw.



Open & close the filter tap while system is pressurised.

## Filter Maintenance

Clean filters ensure that no solids enter the spraying system to block or damage pump or nozzles.

All filters should be cleaned regularly or after each spraying period.

## Suction Filter

The suction filter should be cleaned regularly, or after each spray tank has been emptied.

To clean the filter:

- 1 Completely stop all sprayer functions.
- 2 Place the pump suction valve in the closed position to shut off liquid from the main tank.
- 3 Remove the outer filter screw and bowl.
- 4 Remove the filter screen & thoroughly clean it and other components before reassembling the filter.

Remove & clean the filter element & components.



- 5 Carefully reassemble the filter, ensuring the screen O-Rings are in place, and then, tighten the outer filter screw so that the outer O-ring is properly sealed.

- 6 **Open the pump suction valve** to access liquid from the main tank, then check the filter is sealed correctly.

If leaking, further tighten the outer screw until sealed. If this does not stop the leaking, check the alignment of the O-ring and/or the condition of the O-ring. Replace if necessary.

Vaseline is the best lubricant for filter seals.

## In-line Pressure Filters

The in-line pressure filter should be cleaned regularly, or after each spray tank has been emptied.

To flush each filter, open and close the filter tap while system is pressurised.

The filter & bowl assembly will need to be disassembled for thorough cleaning.

### NOTE

Be careful not to damage or deform the mesh or O-ring while cleaning and refitting the suction filter.  
If the filter screen or O-ring is damaged, replace the part.

### CAUTION

Ensure the **PUMP SUCTION VALVE IS OPEN** before starting the pump.  
Starting the pump with the suction valve closed will seriously damage the suction valve and warranty will be made void.





*Regularly check and clean nozzle filters (if fitted).*

### Nozzle Filters

Nozzle filters should be cleaned regularly to avoid nozzle blockages.

To clean the nozzle filters:

- 1 Completely stop all sprayer functions.
- 2 Remove the nozzle cap and nozzle, and then remove the nozzle filter.
- 3 Thoroughly clean the nozzle filter.  
Replace the filter if damaged.
- 4 If necessary, remove seal and nozzle from the cap to clean the nozzle.
- 5 Reassemble the nozzle components.
- 6 Check that nozzles are sealed correctly by testing with water under full operating pressure before spraying.

If leaking, check caps are correctly fitted with seals or the condition of the seals. Replace if necessary.

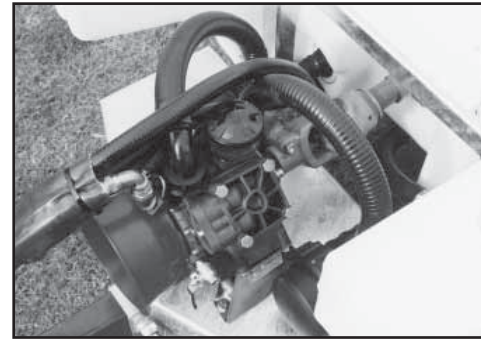

*Fresh water tanks removed for open access.*

### Removal of Fresh Water Tanks - 1500 & 2000 models only

*The fresh water tanks at the front of the sprayer can be quickly and easily removed to gain open access for servicing the pump and/or electric valves.*

To remove the fresh water tanks for servicing follow the steps outlined:

- 1 Unscrew the hose fitting flanges and & remove the hose elbow from flushing tank outlet.

*Unscrew & remove the hose from flushing tank outlet.*

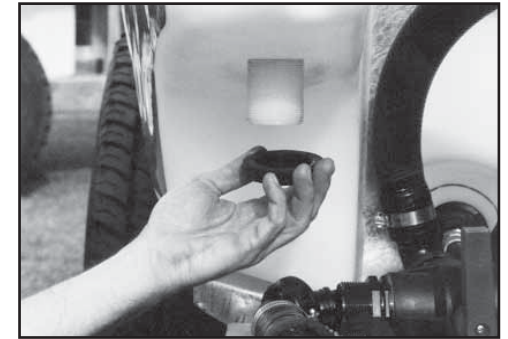
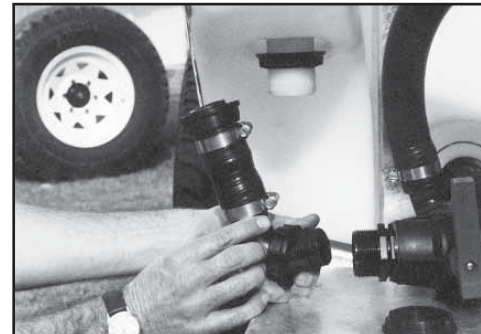

*Remove flange from flushing tank outlet.*

- 2 Unscrew and remove the flange from flushing tank outlet.
- 3 Remove the centre flange from the fresh water tanks located above the PTO shaft.

*Remove the centre flange from the fresh water tanks.*





*Remove the tap from fresh water tank outlet.*

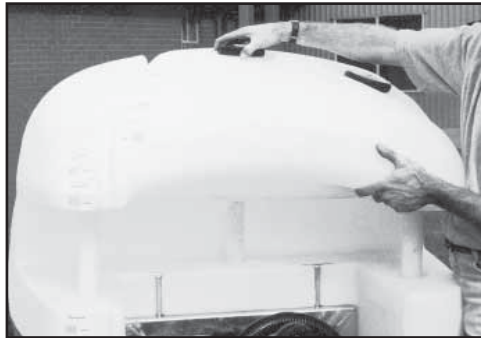

*Raise the fresh water tanks to clear outlets.*



*Front clamps of the main tank.*

- 4 Unscrew and remove the tap from fresh water tank outlet.
- 5 Unscrew and remove the flange from fresh water tank outlet.

- 6 Raise the fresh water tanks to clear the tank outlets.
- 7 Completely remove the fresh water tanks for open access to the pump and PTO shaft.

Follow the procedure in reverse to refit the tanks after servicing.

## Tank Clamps

The tank clamps located at the front and rear of the main tank should be kept tight so that the tank is not free to slide on the chassis.

Tank clamps should be checked two or three times a day when the sprayer is new and the tank and chassis are bedding-in.

Thereafter the tank clamps should be checked regularly.

## Non-Drip Diaphragms

Non-drip diaphragms should be cleaned regularly to prevent dripping from nozzles.

To clean the non-drip diaphragms:

- 1 Completely stop all sprayer functions.
- 2 Unscrew and remove the diaphragm cap.
- 3 Remove and clean any sediment off the diaphragm membrane.  
Replace the diaphragm membrane if damaged.
- 4 Replace the diaphragm.
- 5 Refit the diaphragm cap and carefully tighten.

*Remove flange from fresh water tank outlet.*



*Completely remove the fresh water tanks.*



*Rear clamps of the main tank.*



### NOTE

*Do not over tighten the diaphragm cap. Over tightening the cap may impede flow through the diaphragm.*



Drive Body, HP-219-9D (includes HP-219-25 Coupler)

## Assembly of the QM500 Spray Head

Follow these instructions to repair or replace components of the Quantum Mist spray head.

The fully assembled drive body (HP-219-9D) is now a stand alone, "non serviceable part".

It can be fitted to spray heads back to 2004. Sprayheads prior to 2004 are classified as obsolete.



Hydraulic motor HP-219M9.8CE-1.

The drive body can be coupled with:

- The HP-219M9.8CE hydraulic motor (bare hydraulic [rear port] motor),  
or
- HP-219M9.8CE-1 (hydraulic motor with:
  - Locating ring - HP-219-4A, and
  - Splined coupler - HP-219-24 (male) (ex FISEM 09).

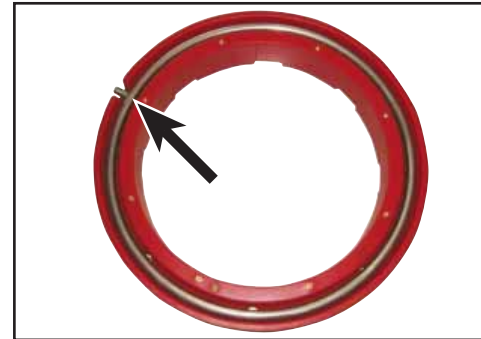

Place the spray ring into the front half of the cowling.

To assemble the QM500 spray head:

- 1 Place the spray ring (HP-219-5D) into the front half of the cowling (as shown above, then assemble the front & rear halves of the cowling.

Fasten the cowling halves and spray ring together using M6 x 60 SS bolts & washers. The nuts are moulded into the front half of the cowling.

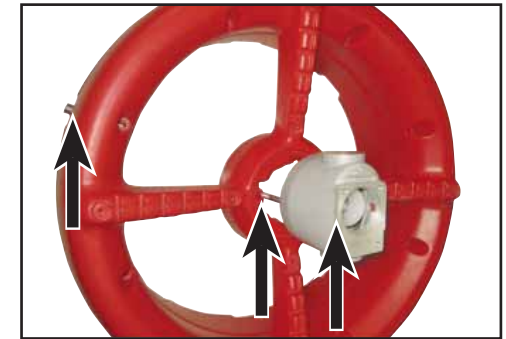

Insert the drive body into the rear of the cowling.

- 2 Assemble the drive body into the back of the cowling.

Ensure the spray ring, cowling and drive body are aligned as shown above.

Fix the drive body with the 3 x M8 x 80 SS studs included with the drive body.

- 3 Turn the unit over & install the retaining flange (HP-219-20) as shown below.

Install the retaining flange (HD-219-20)



### NOTE

There are 2 versions of the retaining flange with the same part number:

- Cast &
- Machined.

The machined version is shown right.



*Assemble the Fan & Mounting Hub.*



*Fit the fan & mounting hub to the drive body shaft*

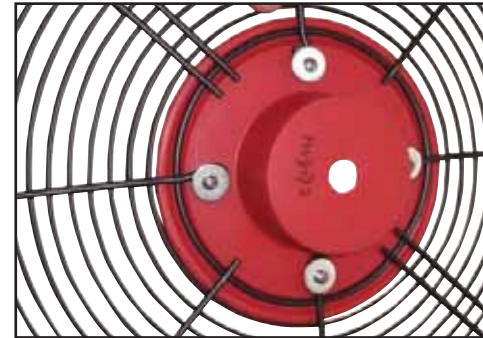

*Assemble the front guard & centre plate.*



*Fit the front guard to the front of the cowling.*

- 4 Assemble the Fan (HP-011D) and the Mounting Hub (HP-219-16C).  
Fasten the fan with M8 x 30 SS bolts and spring washers & flat washers.

- 5 Fit the assembled fan and mounting hub to the drive body shaft with a M8 x 25 SS bolt, spring washer and large flat washer.  
Use Loctite 569 on the bolt thread.  
Ensure the bolt is fully tightened.

- 6 Assemble the front guard (HP-219-6C) and centre plate (HP-219-15B).  
Use (8G) M4.2 x 19 SS screws and M5 x 20 SS washers.

- 7 Fit the front & rear guards onto the cowling using (8G) M4.2 x 19 SS screws and M5 x 20 SS washers.

## NOTE

*Removal of the mounting hub from the drive body shaft during disassembly (after removal of the fan blade) often requires the use of a puller against the hub.*



*Fit the rear guard to the back of the cowling.*



## Section 5



*Fit the swivels to the spray ring (single nozzle shown).*

- 8 Fit the swivels to the spray ring.
- Three swivel types are available:
- Single nozzle - HP-219-22A / B264.612.172
  - Shut Off Nozzle - B67.617.67
  - Double Nozzle - HP-219-23 / B264.612.171.

**Always** use thread sealant Loctite 569 or equivalent when fitting the swivels.



**Always** use thread sealant Loctite 569 or equivalent when fitting the swivels to the spray ring.



*Fit the mounting bracket to the drive body*

- 9 Fit the mounting bracket HP-219-8B to the drive body.
- Use M12 x 40 SS bolts and spring washers.



*Fit the hydraulic motor to the drive body*

- 10 Fit the hydraulic motor to the drive body using M6 x 25 SS bolts and washers.

*Shut Off Nozzle shown (left) & Double Nozzle (right).*

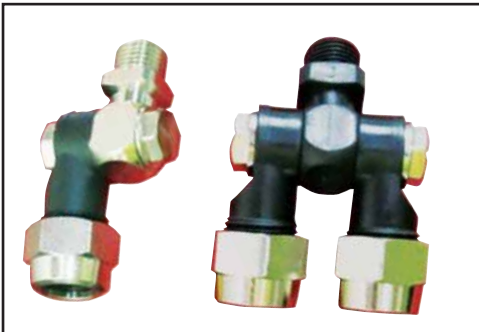



<b>Diaphragm Pump Problems</b>	<b>6.2</b>
<b>General Sprayer Problems</b>	<b>6.4</b>

PROBLEM	PROBABLE CAUSE	REMEDY
<b>A Pump does not draw or deliver liquid. Pressure gauge fluctuates badly.</b>	<ol style="list-style-type: none"> <li>1 One or more valves are not seating properly.</li> <li>2 The pump is sucking in air through suction line.</li> <li>3 Air has not been entirely evacuated from the pump.</li> <li>4 Blocked suction filter.</li> <li>5 Damaged or worn suction valves.</li> </ol>	<ol style="list-style-type: none"> <li>1 Clean valve seating.</li> <li>2 Examine the suction hose and ensure it is firmly secured.</li> <li>3 Rotate the pump with outlet hose and taps open.</li> <li>4 Clean suction filter.</li> <li>5 Replace suction valves.</li> </ol>
<b>B Liquid flow is irregular (Also check items under A)</b>	<ol style="list-style-type: none"> <li>1 The air in the air chamber of the pump is incorrectly set.</li> <li>2 Diaphragm split.</li> <li>3 Damaged or worn valves.</li> <li>4 Foreign matter holding valves open.</li> </ol>	<ol style="list-style-type: none"> <li>1 Check pressure in air chamber of pump. Set at 210-280Kpa (30-40 psi).</li> <li>2 Replace diaphragm.</li> <li>3 Replace valves.</li> <li>4 Clean valves.</li> </ol>
<b>C Pump delivers insufficient pressure</b>	<ol style="list-style-type: none"> <li>1 Regulating valve: <ul style="list-style-type: none"> <li>• Sticking open</li> <li>• Not set for pressure.</li> <li>• Damaged or worn seat or spring.</li> </ul> </li> <li>2 Cylinder diaphragm ruptured.</li> <li>3 Pump valves blocked, worn or damaged.</li> <li>4 Spray nozzles worn, missing or exceed pump capacity.</li> </ol>	<ol style="list-style-type: none"> <li>1 Fix the regulator: <ul style="list-style-type: none"> <li>• Unstick the valves.</li> <li>• Set the pressure.</li> <li>• Replace the spring.</li> </ul> </li> <li>2 Replace diaphragms.</li> <li>3 Unblock valves and or replace.</li> <li>4 Replace spray nozzles with appropriate size.</li> </ol>
<b>D Output drops &amp; pump is noisy.</b>	<ol style="list-style-type: none"> <li>1 Oil level is too low.</li> </ol>	<ol style="list-style-type: none"> <li>1 Top up with oil to correct level (1/2 way up the sight glass).</li> </ol>



PROBLEM	PROBABLE CAUSE	REMEDY
<b>E Oil being discharged through delivery line or discoloured oil in sight glass of pump.</b>	1 One or more diaphragms split or ruptured.	1 Immediately drain oil from pump and flush to remove all spray residues from sump. Remove pump heads & fit new diaphragms.  Fill to correct level with motor oil 20W/30.
<b>SUCTION SIDE OF PUMP</b>		
<b>F Suction hose vibration.</b>	1 Air getting into suction.	1 Seal all joints securely with tape or stag. Firm up clamps. 2 Check the suction filter is sealed.
<b>G Pump valves hammering.</b>	1 Suction tap partly turned off. 2 Suction strainer(s) blocked.	1 Turn tap fully on. 2 Clean filters.
<b>H No water flow in suction hose.</b>	1 Obstruction in tank or suction line. 2 Suction tap in OFF position	1 Clean foreign material from tank & suction line. 2 Turn suction tap ON.
<b>DISCHARGE SIDE OF PUMP</b>		
<b>I Pressure gauge pointer swings violently.</b>	1 Pressure control valve spindle doesn't move easily.	1 Lubricate with light oil or C.R.C.
<b>J AR control valve leaking from spindle.</b>	1 Split diaphragm or O-rings.	1 Remove 4 body set screws, replace diaphragm and O-rings.
<b>K Pressure gauge showing correct working pressure no pressure at nozzle.</b>	1 Burst discharge line. 2 Blocked discharge filter where fitted. 3 O-ring(s) jamming flow in discharge line. 4 Ants, wasps build nests in discharge line or nozzles.	1 Replace discharge line. 2 Clean discharge filter. 3 Clean discharge line of foreign materials. 4 Clean nozzles of foreign materials with tooth brush

PROBLEM	PROBABLE CAUSE	REMEDY
<b>1 No spray when turned on.</b>	<ol style="list-style-type: none"> <li>1 Filter on the inlet side of the pump blocked.</li> <li>2 Faulty pump.</li> <li>3 Control valves not working.</li> </ol>	<ol style="list-style-type: none"> <li>1 Dismantle, clean &amp; re-assemble.</li> <li>2 Change pump.</li> <li>3 Check all motor valves.</li> </ol>
<b>2 Sprays for short time only.</b>	<ol style="list-style-type: none"> <li>1 Air inlet to tank blocked.</li> <li>2 Filter on suction side of pump blocking or blocked.</li> </ol>	<ol style="list-style-type: none"> <li>1 Clean air vent.</li> <li>2 Dismantle, clean &amp; re-assemble the filter. If filter problem persists, clean out the tank &amp; start again.</li> </ol>
<b>3 Spray is uneven around the spray-head.</b>	<ol style="list-style-type: none"> <li>1 Some nozzle filters or tips are blocked.</li> <li>2 Nozzle tips worn.</li> <li>3 Different pressure at nozzles; wrong nozzles fitted.</li> </ol>	<ol style="list-style-type: none"> <li>1 Remove, clean &amp; check. Check output &amp; for streaks.</li> <li>2 Check nozzle output, replace worn nozzles.</li> <li>3 Remove a nozzle in each section &amp; check that flow rate is the same. If different, check for blockages.</li> </ol>
<b>4 Pressure going up - output going down.</b>	<ol style="list-style-type: none"> <li>1 Nozzle filters blocking.</li> <li>2 Pressure filter blocking.</li> </ol>	<ol style="list-style-type: none"> <li>1 Dismantle, clean &amp; refit. Check pressure returns to normal. Check all filters and spray mixture.</li> <li>2 Check &amp; clean the pressure filter.</li> </ol>
<b>5 Pressure falling.</b>	<ol style="list-style-type: none"> <li>1 Filter on suction side blocked.</li> <li>2 Nozzle tips worn.</li> <li>3 Pressure gauge faulty.</li> <li>4 Pump worn.</li> </ol>	<ol style="list-style-type: none"> <li>1 Dismantle &amp; clean the filter.</li> <li>2 Check nozzle output, replace worn nozzles.</li> <li>3 Check with new pressure gauge.</li> <li>4 Repair or replace the pump.</li> </ol>
<b>6 Spray pattern narrow or faltering.</b>	<ol style="list-style-type: none"> <li>1 Pressure too low.</li> <li>2 Nozzles blocked or partially blocked.</li> </ol>	<ol style="list-style-type: none"> <li>1 Check that the correct nozzles are being used.</li> <li>2 Check that the tank is not empty. If not, there is an air leak between the pump &amp; tank or in the pump. Check plumbing &amp; repair.</li> <li>3 Check nozzles &amp; clean as required.</li> </ol>
<b>7 Foam in the tank.</b>	<ol style="list-style-type: none"> <li>1 Too much agitation.</li> </ol>	<ol style="list-style-type: none"> <li>1 Switch Off one or both agitators.</li> </ol>

<b>Pumps</b>	<b>7.2</b>
<b>UCM/ECM Controllers</b>	<b>7.8</b>
<b>Single Row Drawing &amp; Parts</b>	<b>7.10</b>
<b>Over Row Drawing &amp; Parts</b>	<b>7.15</b>
<b>Three Row Drawing &amp; Parts</b>	<b>7.20</b>
<b>Axle &amp; Stub Axles</b>	<b>7.23</b>
<b>QM500 Spray Head Assembly</b>	<b>7.33</b>
<b>Liquid System Components</b>	<b>7.38</b>
<b>Electrical Diagrams</b>	<b>7.40</b>
<b>Plumbing Diagrams</b>	<b>7.43</b>
<b>Hydraulic Diagrams</b>	<b>7.48</b>
<b>Useful Formulae for Calibrating Sprayers</b>	<b>7.57</b>

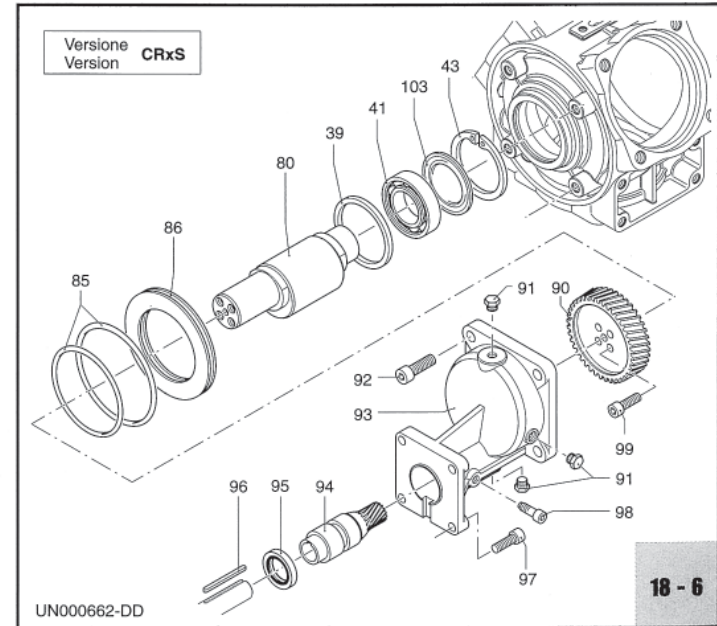
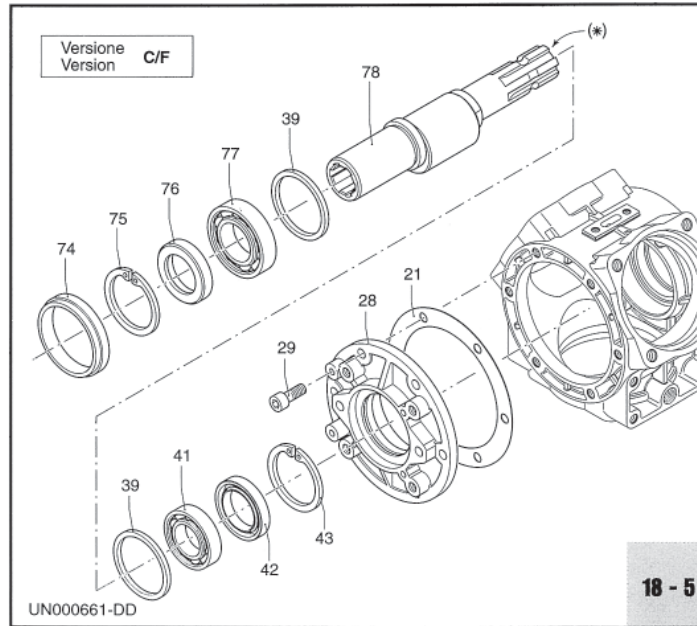
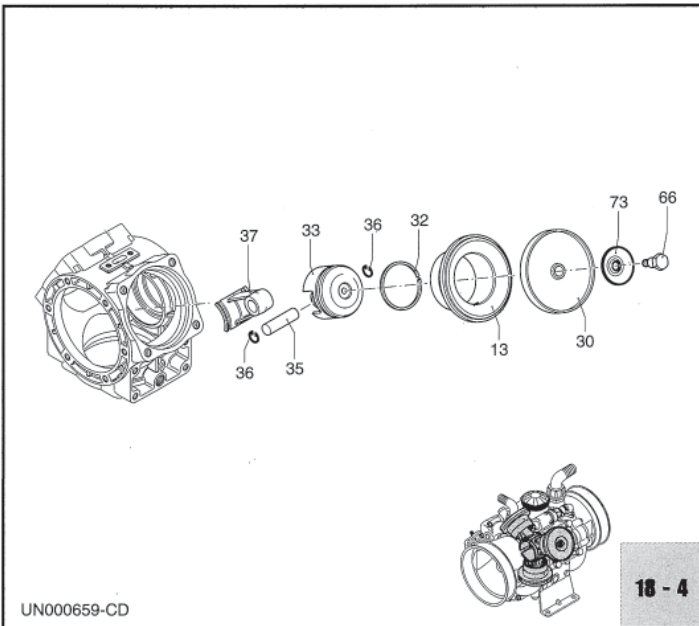
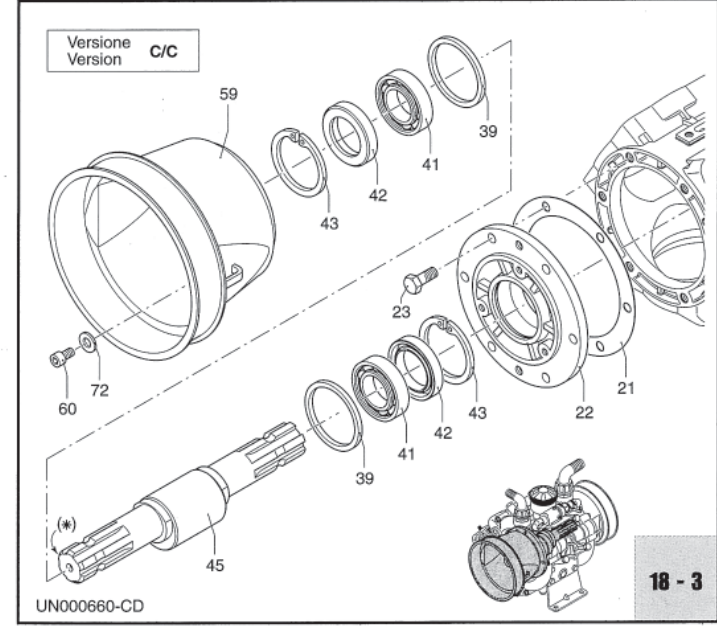
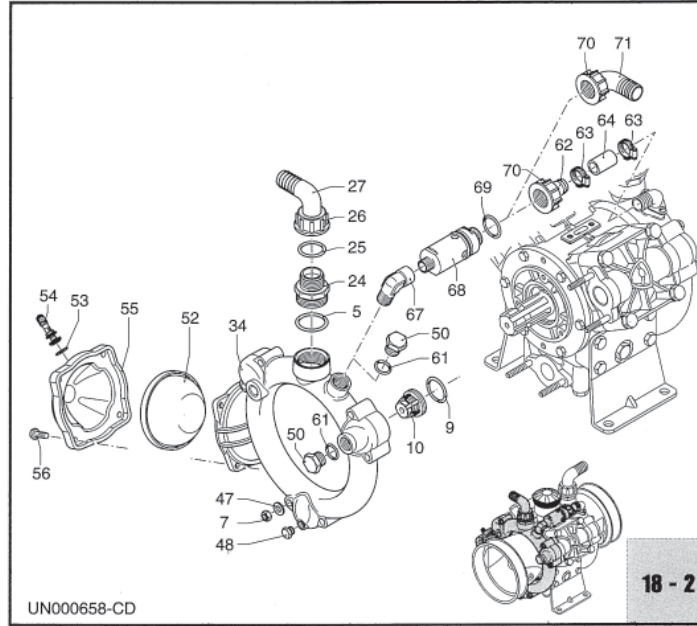
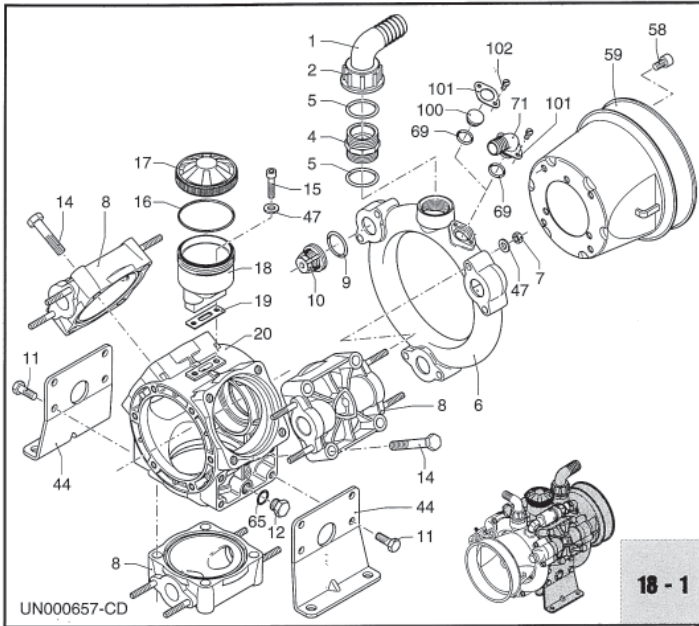



Pos	Part No	Description	Qty
1	AR540550	Elbow	1
2	AR540540	Ring nut	1
4	AR540530	Threaded adapter	1
5	AR250310	O-Ring	3
6	AR2420020	Suction manifold	1
7	AR380242	Nut	12
8	AR750100	Head	3
9	AR680070	O-Ring	6
10	AR759051	Complete valve	6
11	AR620341	Bolt	8
12	AR880530	Plug	1
13	AR750110	Sleeve	4
13	AR750115	Sleeve	4
14	AR750061	Bolt	12
15	AR680350	Bolt	2
16	AR1040060	O-Ring	1
17	AR750057	Black oil tank cap	1
17	AR750052	Red oil tank cap	1
18	AR750030	Oil tank	1
19	AR750040	Gasket	1
20	AR2420010	Pump body	1
21	AR680250	Gasket	1
22	AR680020	Shaft support	1
23	AR160672	Bolt	6
24	AR580170	Threaded adapter	1
25	AR550350	O-Ring	1
26	AR550242	Ring nut	1
27	AR550370	Elbow	1
28	AR2420180	Shaft support	1
29	AR621500	Bolt	6
30	AR550084	Diaphragm - VITON	3
30	AR550086	Diaphragm - HDPS (Recommended)	3
32	AR500260	Piston ring	3
33	AR750122	Piston	3
34	AR2420030	Manifold	1
35	AR160700	Pin	3
36	AR160691	Pin circlip	6
37	AR2420070	Connecting rod	3
39	AR2420080	Con rod ring	2
41	AR230350	Bearing	2
42	AR160740	Seal ring	2
43	AR200390	Circlip	2
44	AR2420041	Base	2
45	AR2420060	VC.' shaft	1
45	AR2420050	VC shaft	1
47	AR380243	Washer	14
48	AR620301	Plug	1
50	AR330173	Plug	2

Pos	Part No	Description	Qty
52	AR550190	Semi air chamber - STANDARD	1
52	AR550191	Semi air chamber	1
52	AR550192	Semi air chamber - VITON	1
52	AR550193	Semi air chamber	1
53	AR650542	Gasket	1
54	AR550300	Air valve	1
55	AR550233	Upper air chamber	1
56	AR550680	Bolt	4
58	AR820671	Bolt	4
59	AR1500350	Shaft guard	2
60	AR850251	Bolt	3
61	AR180101	O-Ring	2
62	AR2420130	Hose tail	1
63	AR1140690	Clamp	2
64	AR2420140	Hose	1
65	AR740290	O-Ring	1
66	AR580360	Diaphragm pin	4
67	AR881560	Safety valve elbow	1
68	AR1609000	Safety valve	1
69	AR880831	O-Ring	2
70	AR550450	Ring nut	1
71	AR550460	Elbow	1
72	AR390314	Washer	3
73	AR580370	Plate	3
74	AR2420250	Bushing	1
75	AR620330	Circlip	1
76	AR1800090	Seal ring	1
77	AR230310	Bearing	1
78	AR2420200	"C/F" shaft	1
78	AR2420190	"C/F" shaft	1
80	AR2420100	"CCxS" shaft	1
80	AR2420090	"CCxS" shaft	1
85	AR620561	O-Ring	2
86	AR621440	Spigot	1
90	AR550940	Gear	1
91	AR620301	Plug	3
92	AR160671	Bolt	4
93	AR621810	Gear box	1
94	AR621820	Pinion	1
95	AR480820	Seal	1
96	AR881090	Key	1
97	AR651000	Bolt	4
98	AR800800	Bolt	1
99	AR540290	Bolt	4
100	AR2420120	Flange plug	1
101	AR2420110	Flange	1
102	AR1982090	Bolt	2
103	AR760410	Cover	1

**NOTE**

*Parts in Italics are non-stocked items and may need to be ordered.*

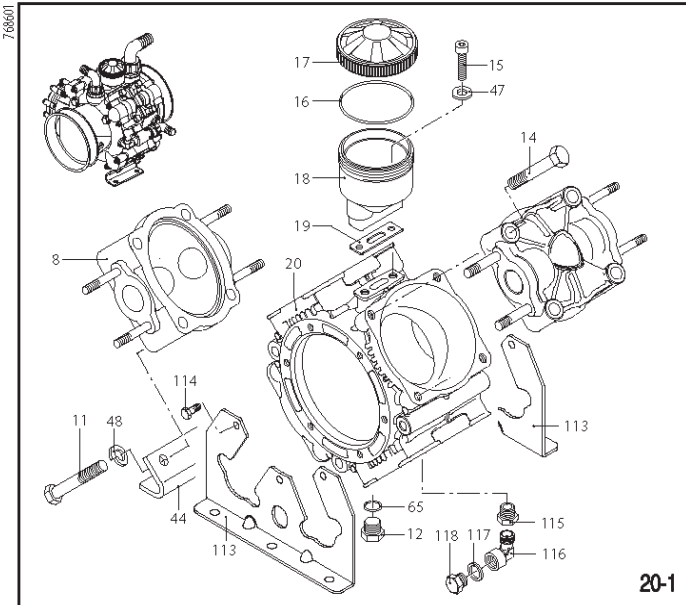

SL00209-AU

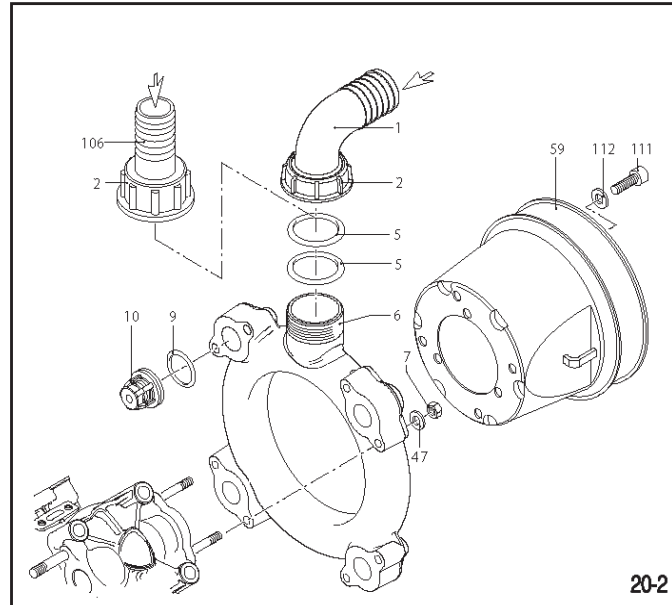

SL000155-DV

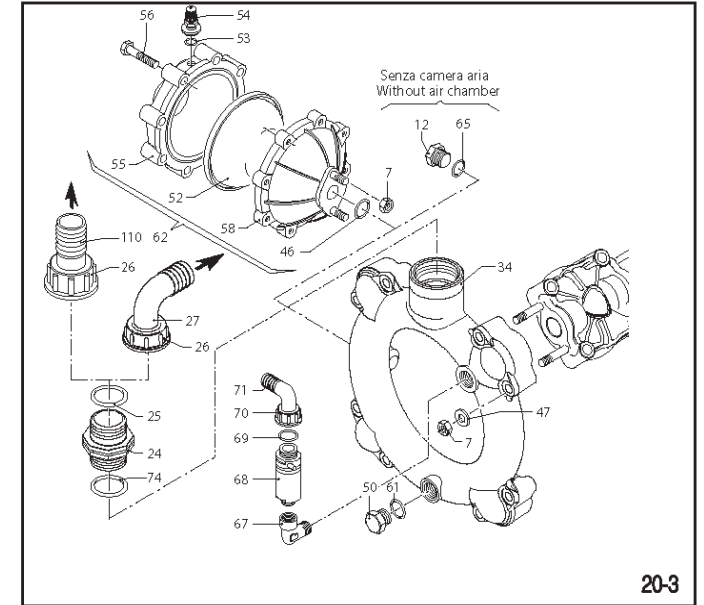

SL000156-DV

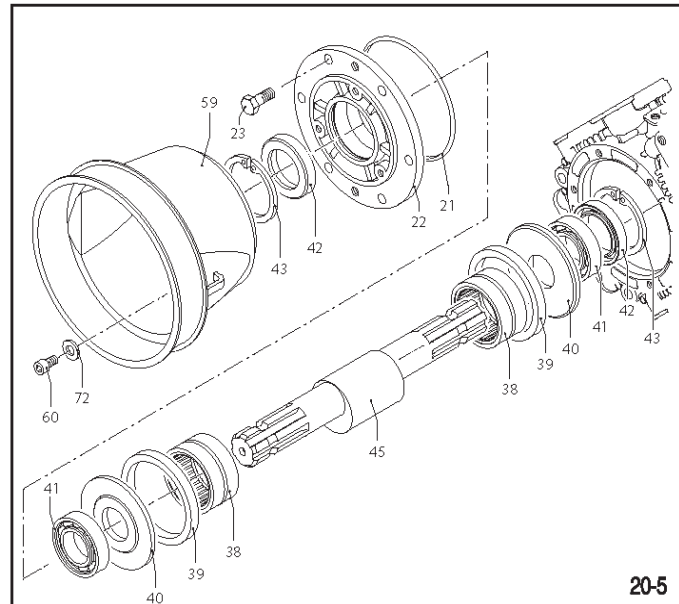

UN000714-ID

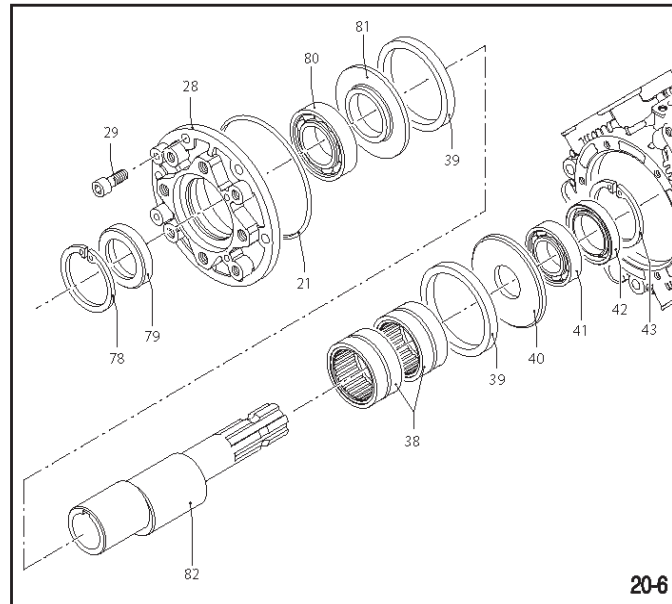

UN000715-IB

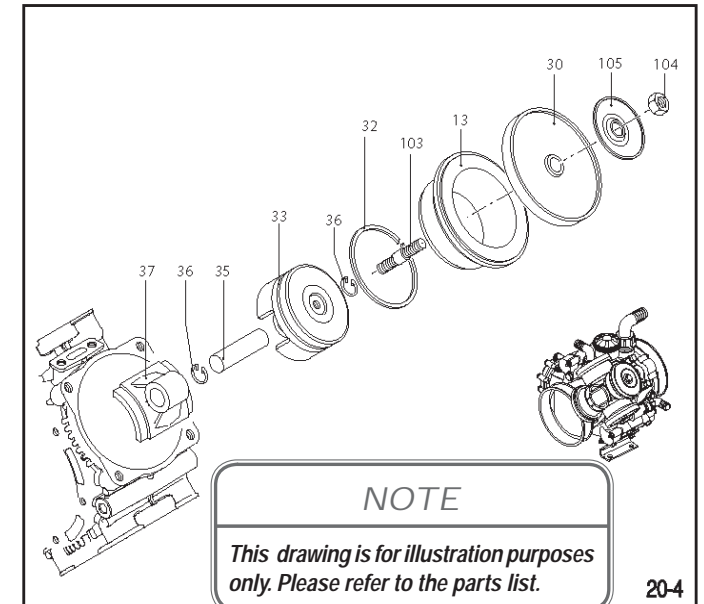

SL000208-AU

**NOTE**  
 This drawing is for illustration purposes only. Please refer to the parts list.

Pos	Part No	Description	Qty
1	AR3040430	Ø 40 Elbow - AR 160 bp	1
	AR3040440	Ø 50 Elbow - AR 185 bp	1
2	AR3040450	2" G Ring nut	1
5	AR3040470	OR Ø 39.3 x 2.6 O-ring	2
6	AR760750	Line	1
7	AR380242	M8 Nut - Geomet C 20	18
	AR380244	M8 Nut - Inox C 20	18
8	AR751350	Head	4
	AR751352	Head	4
9	AR680070	OR Ø 31.5 x 4.25 O-ring	8
10	AR759051	Valve	8
11	AR750071	TE M12 x 70 Screw - Geomet C 50	4
	AR750072	TE M12 x 70 Screw	4
12	AR880530	3/8" G Plug - C 20	2
	AR2340350	3/8" G Plug - Inox C 20	2
13	AR750110	Sleeve - AR 160 bp	4
	AR750115	Sleeve - AR 185 bp	4
14	AR750061	TE M12 x 65 Screw - Geomet C 50	12
	AR750062	TE M12 x 65 Screw - Inox C 50	12
15	AR680350	TCEI M8 x 35 Screw	2
16	AR1040060	Ø 72.69 x 2.62 O-ring	1
17	AR750057	Plug - AR 160 bp	1
	AR750052	Plug - AR 185 bp	1
18	AR750030	Tank	1
19	AR750040	Gasket	1
20	AR761010	Pump body	1
21	AR851360	Ø 120.32 x 2.62 O-ring	1
22	AR680020	Support	1
23	AR160672	TE M10 x 25 Screw - Geomet C 40	6
	AR160673	TE M10 x 25 Screw - Inox C 40	6
24	AR751130	1" 1/2 G M-M Fitting	1
25	AR390290	Ø 29x3 O-ring	1
26	AR750670	1" 1/2 G Ring nut	1
27	AR760930	Ø 25 Elbow - AR 160 bp	1
	AR3040160	Ø 35 Elbow - AR 185 bp	1
28	AR2420181	Support	1
29	AR650640	TCEI M10 x 25 Screw - Geomet C 40	6
	AR650642	TCEI M10 x 25 Screw - Inox C 40	6
30	AR550080	Diaphragm - NBR	4
	AR550084	Diaphragm - Viton	4
	AR550085	Diaphragm - Desmopan	4
	AR550086	Diaphragm - HPDS	4
32	AR500260	Piston ring	4
33	AR750122	Ø 80 Piston	4
34	AR760760	Line	1
35	AR160700	Pin	4
36	AR160691	Øi 18 Ring	8
37	AR760140	Connecting-rod	4
38	AR750090	Bearing	2
39	AR750130	Ring	2
40	AR540040	Plate	2
41	AR230350	Bearing	2
42	AR160740	Ring	2
43	AR200390	Øi 62 Ring	2
44	AR760201	Foot	2
45	AR750170	C/C m-AU Shaft - AR 160 bp	1
	AR750174	C/C m-AV Shaft - AR 185 bp	1

## NOTE

*Parts in Italics are non-stocked items and may need to be ordered.*

Pos	Part No	Description	Qty
46	AR390290	Ø 29x3 O-ring	1
47	AR380243	Washer - Geomet	18
	AR390315	Washer - Inox	18
48	AR250143	Washer - Geomet	4
	AR250144	Washer - Inox	4
50	AR330173	1/2" G Plug - Geomet C 20	1
	AR330174	1/2" G Plug - Inox C 20	1
52	AR550190	Semi air chamber - NBR	1
	AR550191	Semi air chamber - Saturflon	1
	AR550192	Semi air chamber - Viton	1
	AR550193	Semi air chamber - HPDS	1
53	AR650542	Gasket	1
54	AR180020	Air valve	1
55	AR620232	Semi air chamber	1
56	AR621781	TE M8 x 40 Screw	8
62	AR1782	TE M8 x 40 Screw	8
58	AR680180	Halfball	1
59	AR1500470	Cardan protection	2
60	AR850251	M8 x 12 Screw	3
	AR850252	TCEI M8 x 12 Screw	3
61	AR180101	Ø 17.5 x 2 O-ring	1
62	AR1552	Air chamber	1
65	AR740290	Ø 14 x 1.78 O-ring 2	
67	AR881560	1/2" G M-F Fitting 1	
68	AR1609000	Safety valve	1
69	AR880831	Ø 15.54 x 2.62 O-ring - Viton	1
70	AR550450	3/4" G Ring nut	1
71	AR550460	Ø 18 Elbow	1
72	AR390314	Washer - Geomet	3
	AR390315	Washer - Inox	3
74	AR751140	Ø 47.22 x 3.53 O-ring	1
78	AR620330	Øi 65 Ring	1
79	AR1800090	Ring	1
80	AR230310	Bearing	1
81	AR760510	Plate	1
82	AR760450	C/F Ø25 m-BX Shaft - AR 160 bp	1
	AR760520	C/F Ø32 m-BS Shaft - AR 160 bp	1
	AR760460	C/F Ø25 m-BZ Shaft - AR 185 bp	1
	AR760530	C/F Ø32 m-BT Shaft - AR 185 bp	1
103	AR2240100	Hub pin	4
104	AR2240110	M10 Nut	4
105	AR751250	Wobble plate	4
106	AR760950	Ø 40 Hose tail - AR 160 bp	1
	AR760570	Ø 50 Hose tail - AR 1854 bp	1
110	AR760920	Ø 25 Hose tail - AR 160 bp	1
	AR760940	Ø 35 Hose tail - AR 185 bp	1
111	AR820673	TCEI M10 x 16 Screw - Geomet	3
	AR820672	TCEI M10 x 16 Screw - Inox	3
112	AR320621	Washer 3 Geomet	
	AR320622	10.5 x 21x 2 Washer - Inox	3
113	AR761030	Foot	2
114	AR160672	TE M10 x 25 Screw - Geomet C 20	6
	AR160673	TE M10 x 25 Screw - Inox C 20	6
115	AR1040491	3/8" M-F Fitting	1
116	AR900210	3/8" G M-F Fitting	1
117	AR2260200	Washer	1
118	AR2281270	3/8" G Plug	1



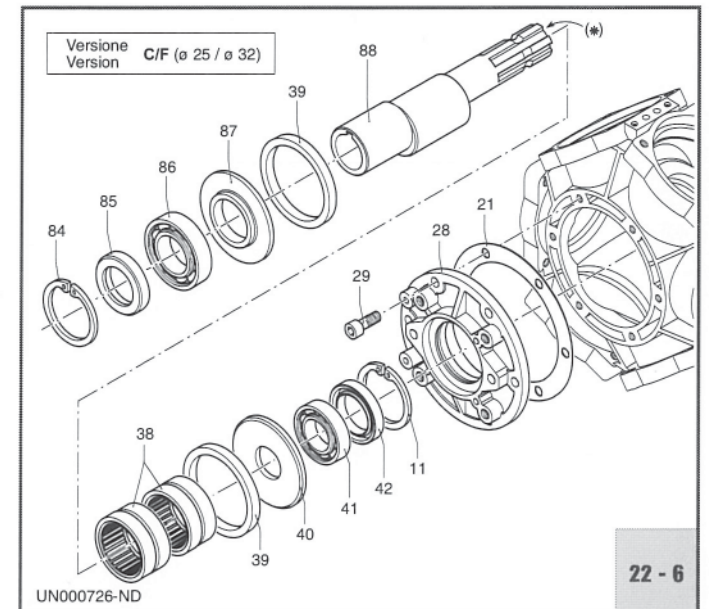
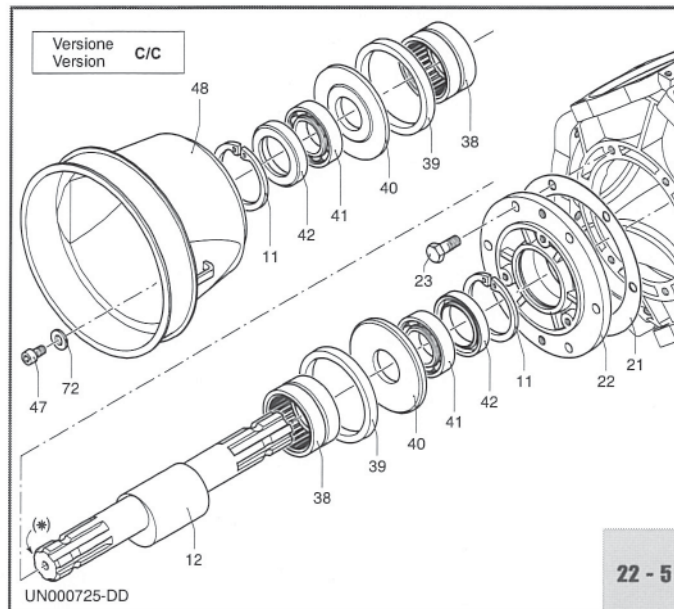
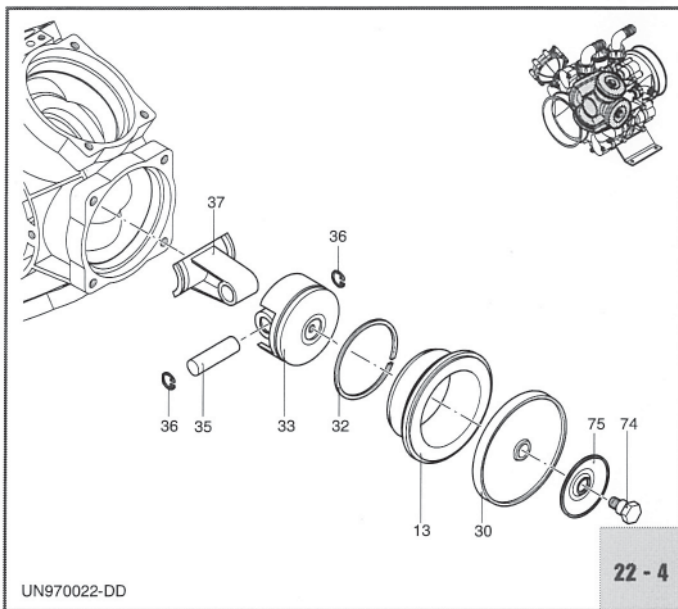
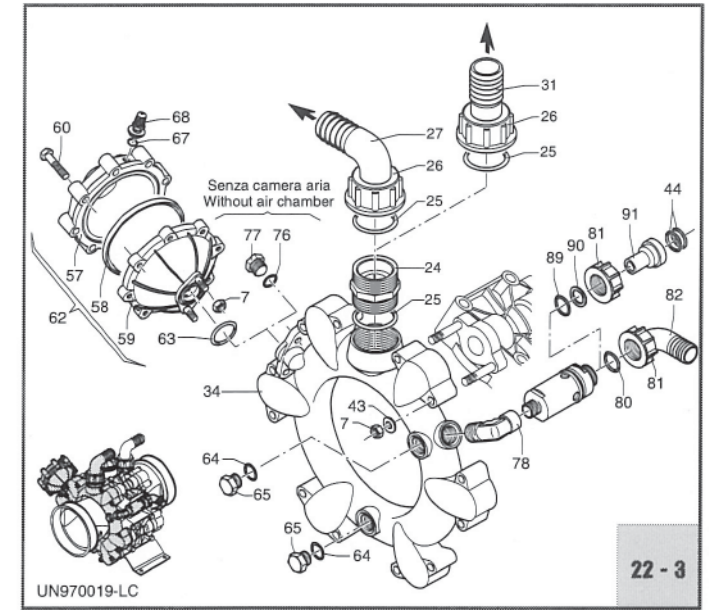
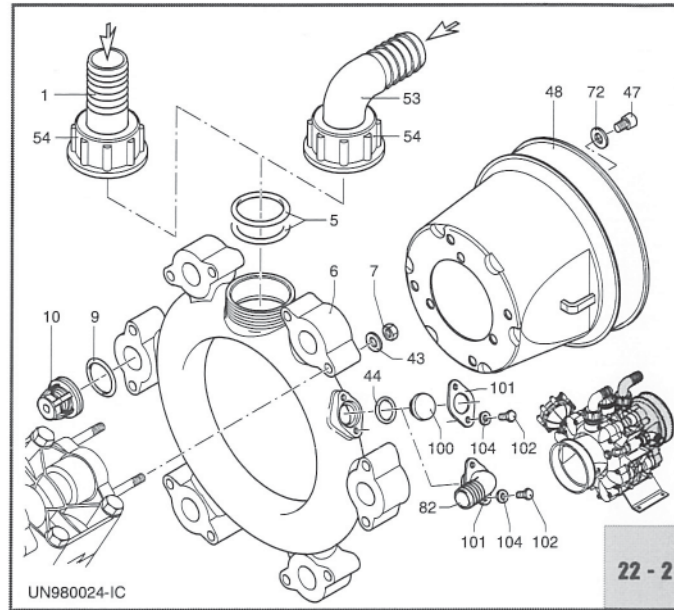
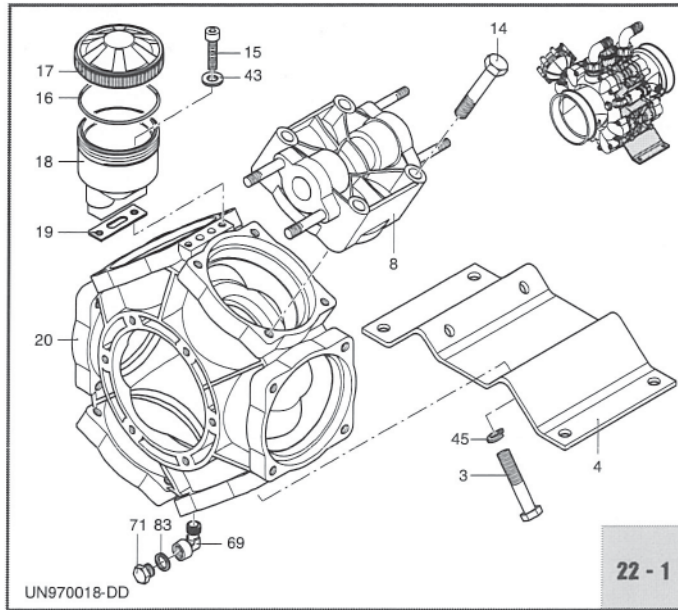



Pos	Part No	Description	Qty
1	AR750870	<i>ø 50 Hose tail</i>	1
	AR750730	<i>ø 60 Hose tail</i>	1
3	AR750071	<i>M12 x 70 Bolt</i>	4
4	AR750200	Base plate	1
5	AR750740	74 x 3.53 O-Ring	2
6	AR750860	Suction manifold	1
7	AR380242	<i>Nut</i>	26
8	AR750100	Head	6
9	AR680070	O-Ring	12
10	AR759051	Complete valve	12
11	AR200390	Circlip	2
12	AR750170	Crankshaft AR 250 bp (AU)	1
13	AR750110	<i>Sleeve AR 250 bp</i>	6
14	AR750061	<i>M 12x65 Bolt</i>	20
15	AR680350	M8 x 35 Bolt	2
16	AR1040060	O-Ring	1
17	AR750057	<i>Black oil tank cap AR 250 bp</i>	1
18	AR750030	Oil tank	1
19	AR750040	Gasket	1
20	AR750010	Pump body	1
21	AR680250	Gasket	1
22	AR680020	<i>Shaft support</i>	1
23	AR160672	<i>M 10x25 Bolt</i>	6
24	AR540530	1"1/4-1"3/4 G (M) Threaded adapter	1
25	AR250310	O-Ring	2
26	AR540540	1"3/4 G Ring nut	1
27	AR392130	<i>ø 35 Elbow</i>	1
28	AR2420180	<i>Shaft support</i>	1
29	AR621500	<i>M10 x 25 Bolt</i>	6
30	AR550084	<i>Diaphragm - VITON</i>	6
	AR550086	Diaphragm - HPDS (Recommended)	6
31	AR391930	<i>ø 35 Hose tail Optional</i>	1
32	AR500260	Piston ring	6

Pos	Part No	Description	Qty
33	AR750122	Piston 80mm	6
34	AR750420	Manifold	1
35	AR160700	Pin	6
36	AR160691	Pin circlip	12
37	AR750140	<i>Connecting rod</i>	6
38	AR750090	Roller bearing	2
39	AR750130	Con rod ring	2
40	AR540040	<i>Spacer washer</i>	2
41	AR230350	Bearing	2
42	AR160740	Seal Ring 35 x 52 x 12mm	2
43	AR380243	<i>Washer</i>	26
44	AR480440	O-Ring	3
45	AR250143	<i>Washer</i>	4
47	AR850251	<i>M8 x 12 Bolt</i>	6
48	AR1500350	Shaft guard	2
53	AR750850	<i>ø 50 Elbow AR 250 bp</i>	1
54	AR750710	2"1/2 G Ring nut	1
57	AR620232	<i>Upper air chamber</i>	1
58	AR550190	Semi air chamber - RUBBER	1
	AR550192	<i>Semi air chamber - VITON</i>	1
	AR550193	<i>Semi air chamber - HPDS</i>	1
59	AR680180	Lower air chamber	1
60	AR621781	<i>M8 x 40 Bolt</i>	8
62	AR1552	Complete air chamber	1
63	AR390290	O-Ring	1
64	AR180101	O-Ring	2
65	AR330173	<i>1/2" G Plug</i>	2
67	AR650542	Gasket	1
68	AR180020	Air valve	1

## NOTE

*Parts in Italics are non-stocked items and may need to be ordered.*

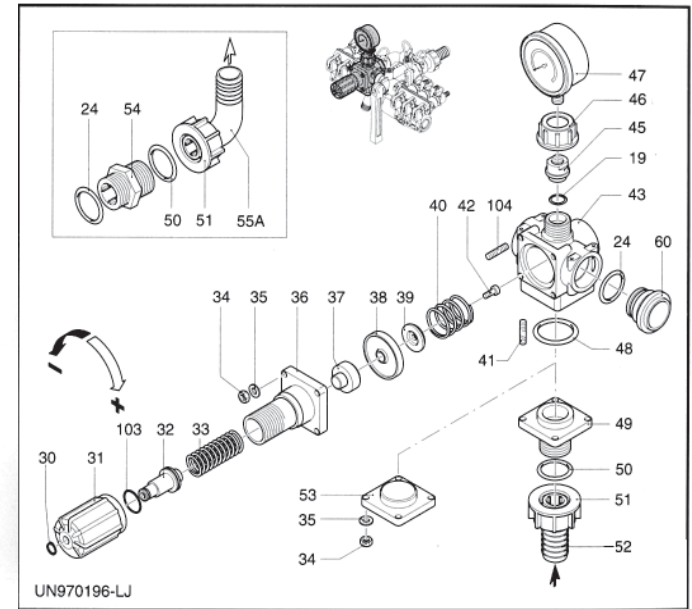
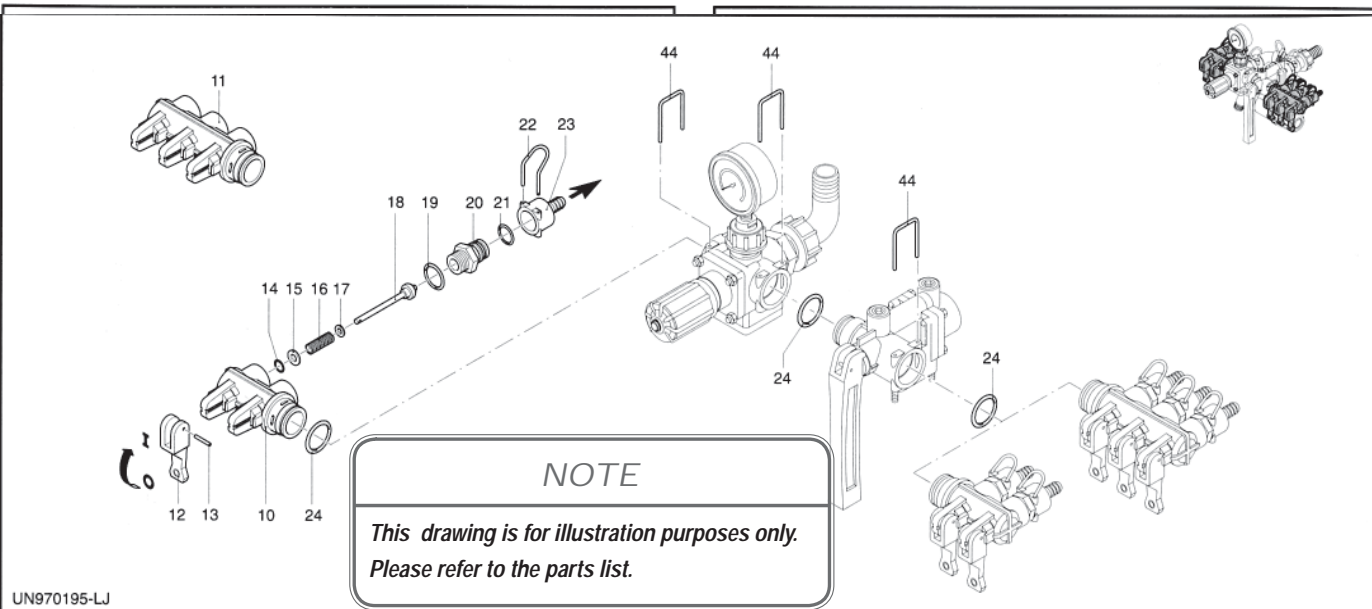
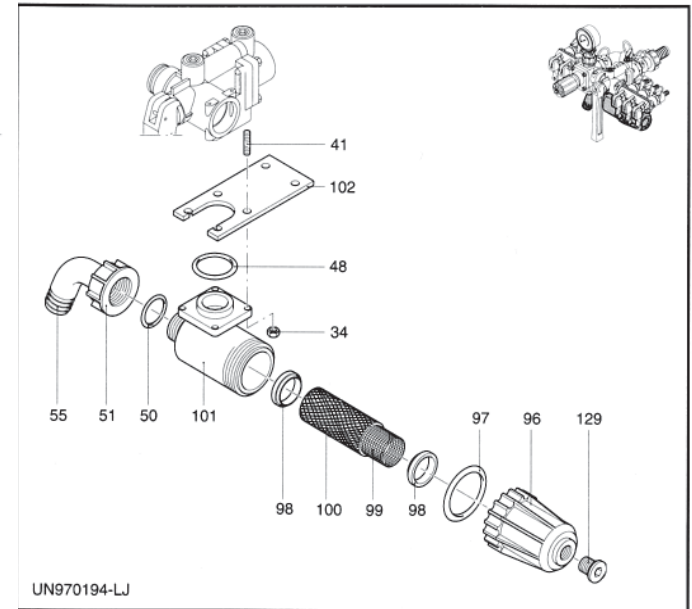
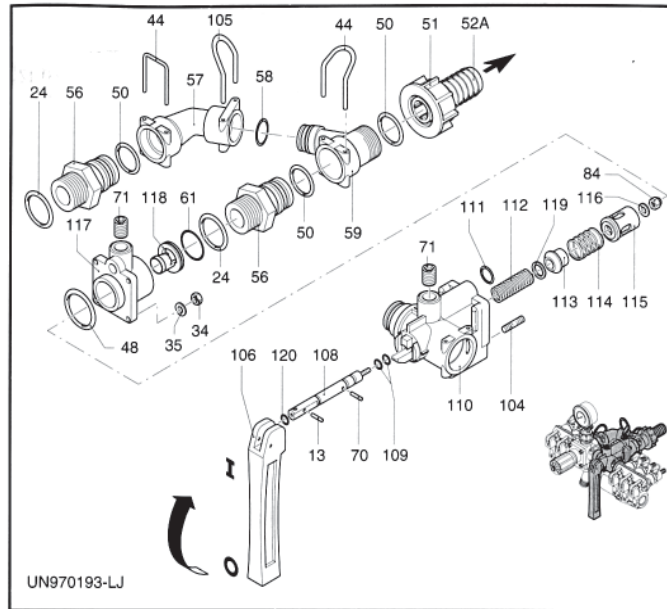
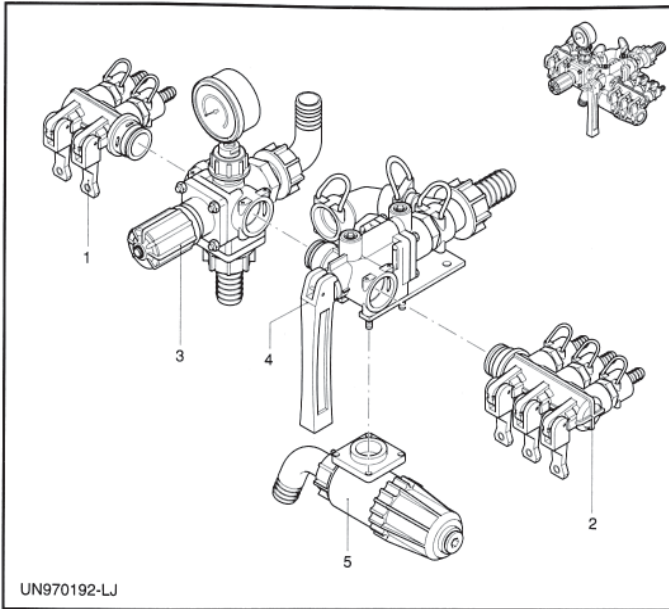

# Section 7

# UCM/ECM Controllers (Pressure Relief Valve)

Pos	Part No	Description	Qty
1	AR1547	Left 2-way valve	1
1	AR1548	Left 3-way valve	1
2	AR1571	Right 2-way valve	1
2	AR1572	Right 3-way valve	1
3	AR1348	ECM compl.reg.valve	1
3	<i>AR1349</i>	<i>UCM compl.reg.valve</i>	<i>1</i>
4	AR1351	Distributor main body	1
5	AR1553	<i>Complete filter</i>	<i>1</i>
10	AR394850	2-way valve body	1
11	AR394860	3-way valve body	1
12	AR394690	Red valve lever	4
13	AR390330	Pin	5
14	AR390341	O-Ring	4
15	AR390312	Washer	4
16	AR390300	Spring	4
17	AR390313	Washer	4
18	AR390323	Complete valve rod	4
19	AR180101	O-Ring	5
20	AR392600	Threaded adapter	4
	<i>AR392604</i>	<i>Plug - optional</i>	
21	AR640070	O-Ring	4
22	AR392580	Fork	4
23	AR392870	Hose tail	4
	AR392590	Hose tail	4
	AR392620	Hose tail	4
24	AR390291	O-Ring	5
30	AR480550	Circlip	1
31	AR394790	Adjustment knob	1
32	AR394770	Spring pin	1
33	AR1040830	Spring	1
34	AR390440	Nut	16
35	AR550331	Washer	12
36	AR394780	Upper body	1
37	AR394751	Piston	1
38	AR394741	Diaphragm - RUBBER	1
	<i>AR394740</i>	<i>Diaphragm - DESMOPAN</i>	<i>1</i>
	<i>AR394742</i>	<i>Diaphragm - VITON</i>	<i>1</i>
39	AR394720	Valve	1
40	AR394730	Spring	1
41	AR394830	Stud	8
42	AR680700	Bolt	1
43	AR394700	Regulating valve body	1
44	AR395530	Fork	5
45	AR394800	Pressure gauge attach	1
46	AR550450	Ring nut	1

Pos	Part No	Description	Qty
47	AR391240	Pressure gauge, 0-20 bar	34
48	AR660170	O-Ring	3
49	AR394810	Flange	1
50	AR550350	O-Ring	4
51	AR550242	Ring nut	2
52	AR550210	Hose tail	2
53	AR394840	Flange	1
54	AR550340	Threaded adapter	1
55	AR550370	Elbow	1
56	AR395000	Manifold nipples	2
57	AR395520	Body manifold	1
58	AR390060	O-Ring	1
59	<i>AR395020</i>	<i>Body manifold</i>	<i>1</i>
60	AR394870	Plug	1
61	AR770260	O-Ring	1
70	AR392120	Pin	1
71	AR880581	Plug	2
84	AR395390	Nut	1
96	AR396100	Filter cover	1
97	AR395081	O-Ring - VITON	1
98	AR395071	Filter gasket	2
99	AR396110	Internal filter	1
100	AR396130	External grid	1
101	AR395030	Filter box	1
102	AR394820	Bracket	1
103	AR770130	O-Ring	1
104	AR392330	Stud	8
105	AR850730	Fork	1
106	AR1660560	Control lever	1
108	AR1660020	Complete valve rod	1
109	AR480561	O-Ring - Viton	2
110	AR1660010	Main valve	1
111	AR1660230	O-Ring	1
112	AR1660541	Spring	1
113	AR1660050	Feed rod valve	1
114	AR1660090	Spring	1
115	AR1660080	Guide	1
116	AR393790	Washer	1
117	AR1660060	Flange	1
118	AR1660100	Red seat	1
	AR1660110	Orange seat	1
	AR1660120	Blue seat	1
119	AR1660140	Washer	1
120	AR1660551	O-Ring - VITON	1
129	AR396590	Plug & gasket	1

**NOTE**

*Parts in Italics are non-stocked items and may need to be ordered.*

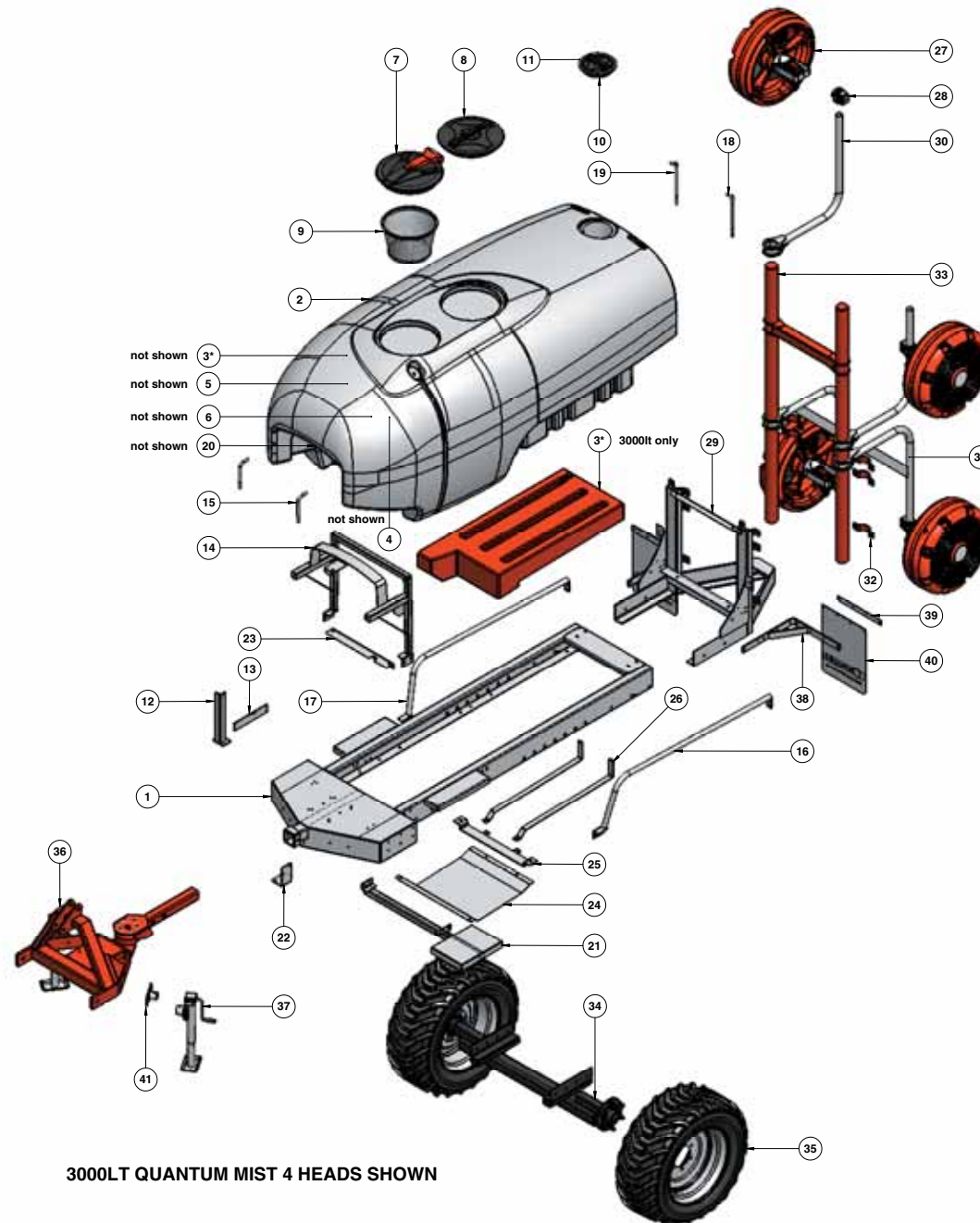

**NOTE**

*This drawing is for illustration purposes only.  
Please refer to the parts list.*



Pos	Part No	Description	Qty
1	HP1500AB	1500LT CHASSIS AIRBLAST	1
2	P1500AB	1500LT TANK POLY AIRBLAST RAW	1
3*		120LT FLUSH TANK (not shown)	1
4		15LT HAND WASH TANK (not shown)	1
5		not applicable	
6	A354030	LID 4" complete with BREATHER & SEAL (not shown)	2
7	A356060	HINGED LID 180 degree 455mm	1
8	A3522040	LID/RING KIT 355mm	1
9	A300130	FILTER BASKET LARGE 254mm DEEP	1
10		not applicable	
11		not applicable	
12	HP-286	BRACKET, CABLE CONTROL	1
13	HP-289	MANIFOLD BRACKET A463CCR008A	1
14	HP-311	FRONT TANK SUPPORT 1500LT	1
15	HP-314	FRONT TIE DOWN ROD 1000/1500LT	2
16	HP-304L	SIDE RAIL L.H. 1500LT	1
17	HP-304R	SIDE RAIL R.H. 1500LT	1
18	HP-315L	REAR LEFT TIE DOWN ROD 1000/1500LT	1
19	HP-315R	REAR RIGHT TIE DOWN ROD 1000/1500LT	1
20		not applicable	
21	HP-402	STEP CROPLINER POLY	1
22	HP-405	BRACKET FILTER SUCTION	1
23	HP-432	BRAGLIA VALVE BRACKET	1
24		not applicable	1
25		not applicable	1
26		not applicable	2

Pos	Part No	Description	Qty
27	KH-5000	QM500 9.8cc SINGLE SWIVEL	4
	KH-5002	QM380 6.5cc SINGLE SWIVEL	4
28	HP-275C	CLAMP QUICK ADJUST	4
	HP-275C-1	CLAMP MOUNT PLATE QM500	4
	HP-275C-2	CLAMP MOUNT PLATE QM380	4
29	HP-274A-1A	SUB FRAME QM 1500LT	1
30	HP-820	BRACKET HOOK TYPE 600mm x 600mm	2
31	HP-829	BRACKET HOOK TYPE 600mm X 1000mm	2
32	HP-274A-14G	CLAMP HALF SADDLE 90mm	6
33	HP-275-2	TOWER TUBE SINGLE ROW	2
34	HP-309	AXLE HOUSING 1500LT	1
	HP-408L	AXLE ADJUSTABLE L.H.	1
	HP-408R	AXLE ADJUSTABLE R.H.	1
	HP-236A	SUSPENSION ASSEMBLY (option)	1
	HP-236A-1	SPACER for SUSPENSION ASSEMBLY (option)	2
35	HP-200	WHEEL/TYRE AWT 11.5/80-15.3	2
	HP-200A	WHEEL/TYRE AWT 10.5/75-15.3 (option)	2
36	HP-400A	DRAWBAR LONG	1
37	MUJOCKEY	JOCKEY WHEEL	1
38		not applicable	
39		not applicable	
40		not applicable	
41		not applicable	

Pos	Part No	Description	Qty
1	HP2000ABA	2000LT CHASSIS AIRBLAST	1
2	P2000AAB-RAW	2000LT TANK POLY AIRBLAST RAW	1
3*	P2000AAB-130RAW	130LT FLUSH TANK (not shown)	1
4	P2000AAB-15RAW	15LT HAND WASH TANK (not shown)	1
5	A354010	LID 6" complete with BREATHER & SEAL (not shown)	1
6	A354030	LID 4" complete with BREATHER & SEAL (not shown)	1
7	A356060	HINGED LID 180 degree 455mm	1
8	A3522040	LID/RING KIT 355mm	1
9	A300130	FILTER BASKET LARGE 254mm DEEP	1
10		not applicable	
11		not applicable	
12	HP-286	BRACKET, CABLE CONTROL	1
13	HP-289	MANIFOLD BRACKET A463CCR008A	1
14	HP-411A	FRONT TANK SUPPORT 2000LT	1
15	HP-414	FRONT TIE DOWN ROD 2000LT	2
16	HP-404LA	SIDE RAIL L.H. 2000LT	1
17	HP-404RA	SIDE RAIL R.H. 2000LT	1
18	HP-415L	REAR LEFT TIE DOWN ROD	1
19	HP-415R	REAR RIGHT TIE DOWN ROD	1
20	HP-413A	TANK SPREADER BAR 2000LT (not shown)	1
21	HP-402A	STEP, RETRACTABLE	1
22	HP-405	BRACKET FILTER SUCTION	1
23	HP-432	BRAGLIA VALVE BRACKET 2000LT	1
24		not applicable	
25		not applicable	
26		not applicable	

Pos	Part No	Description	Qty
27	KH-5000	QM500 9.8cc SINGLE SWIVEL	4
	KH-5002	QM380 6.5cc SINGLE SWIVEL	4
28	HP-275C	CLAMP QUICK ADJUST	4
	HP-275C-1	CLAMP MOUNT PLATE QM500	4
	HP-275C-2	CLAMP MOUNT PLATE QM380	4
29	HP-274A-1	SUB FRAME QM 2000LT	1
30	HP-820	BRACKET HOOK TYPE 600mm x 600mm	2
31	HP-829	BRACKET HOOK TYPE 600mm X 1000mm	2
32	HP-274A-14G	CLAMP HALF SADDLE 90mm	6
33	HP-275-2	TOWER TUBE SINGLE ROW	2
34	HP-409	AXLE HOUSING 2000LT	1
	HP-408L	AXLE ADJUSTABLE L.H.	1
	HP-408R	AXLE ADJUSTABLE R.H.	1
	HP-236A	SUSPENSION ASSEMBLY POLY 2000LT (option)	1
	BP-400D	SUSPENSION TANDEM 2T 2000LT (option)	1
35	HP-200	WHEEL/TYRE AWT 11.5/80-15.3	2
	HP-202	RIM/TYRE 10R X 15 LANDCRUISER (option)	4
36	HP-400A	DRAWBAR LONG	1
37	MUJOCKEY	JOCKEY WHEEL	1
38	HP-288	BRACKET MUDFLAP (tandem option only)	2
39	BP-180	MUDFLAP PLATE (tandem option only)	2
40	BP-542	MUDFLAP WHITE (tandem option only)	2
41		not applicable	

Pos	Part No	Description	Qty
1	HP3000ABA	3000LT CHASSIS AIRBLAST version 2	1
2	P3000AB-RAW	3000LT TANK POLY AIRBLAST RAW	1
3*	P3000AB-110RAW	110LT FLUSH TANK	1
4		10LT HAND WASH TANK (integrated)	1
5		not applicable	
6		not applicable	
7	A356060	HINGED LID 180 degree 455mm	1
8	A3510060	LID/RING KIT 455mm	1
9	A300130	FILTER BASKET LARGE 254mm DEEP	1
10	A3522120	LID 255MM CLOSED	1
11	A350620	LID RING WITH GASKET (3000LT only)	1
12	HP-286	BRACKET, CABLE CONTROL	1
13	HP-289	MANIFOLD BRACKET A463CCR008A	1
14	HP-511A	FRONT TANK SUPPORT 3000LT	1
15	HP-514	FRONT TIE DOWN ROD	2
16	HP-504LA	SIDE RAIL L.H. 3000LT	1
17	HP-504RA	SIDE RAIL R.H. 3000LT	1
18	HP-515L	REAR LEFT TIE DOWN ROD	1
19	HP-515R	REAR RIGHT TIE DOWN ROD	1
20		not applicable	
21	HP-402A	STEP, RETRACTABLE	1
22	HP-405	BRACKET FILTER SUCTION	1
23	HP-432A	BRAGLIA VALVE BRACKET 3000LT	1
24	HP-512	SUMP GUARD QM CHASSIS 3000LT	1
25	HP-520	CROSS RAIL BRACKET FLUSH TANK 3000LT	1
26	HP-521	SUPPORT STRAP FLUSH TANK 3000LT	2
27	KH-5000	QM500 9.8cc SINGLE SWIVEL	4
	KH-5002	QM380 6.5cc SINGLE SWIVEL	4

Pos	Part No	Description	Qty
28	HP-275C	CLAMP QUICK ADJUST	4
	HP-275C-1	CLAMP MOUNT PLATE QM500	4
	HP-275C-2	CLAMP MOUNT PLATE QM380	4
29	HP-283E2	SUB FRAME QM 3000LT version 2	1
30	HP-820	BRACKET HOOK TYPE 600mm x 600mm	2
31	HP-829	BRACKET HOOK TYPE 600mm X 1000mm	2
32	HP-274A-14G	CLAMP HALF SADDLE 90mm	6
33	HP-275-2	TOWER TUBE SINGLE ROW	2
34	HP-205B	AXLE ASSEMBLY SOLID POLY 3000LT	1
	HP-236D	SUSPENSION SINGLE AXLE 3000LT (option)	1
	BP-400JL	SUSPENSION TANDEM ASSEMBLY 3T 3000LT (option)	1
35	HP-202G	WHEEL/TYRE 400 X 15.5 LUG	2
	HP-200A	RIM/TYRE AWT 10.5/75-15.3 (tandem option only)	4
36	HP-024C	3 POINT LINKAGE SELF STEER DRAWBAR	1
37	BP-184	JOCKEY STAND (long)	2
38	HP-288	BRACKET MUDFLAP (tandem option only)	2
39	BP-180	MUDFLAP PLATE (tandem option only)	2
40	BP-542	MUDFLAP WHITE (tandem option only)	2
41	HP-006	SPIGOT PLATE JACK STAND	2

Pos	Part No	Description	Qty
1	HP4000ABA	4000LT CHASSIS AIRBLAST	1
2	P4000AB-RAW	4000LT TANK POLY AIRBLAST RAW	1
3*		80LT FLUSH TANK (integrated)	1
4		not applicable	
5		not applicable	
6		not applicable	
7	A356060	HINGED LID 180 degree 455mm	1
8	A3510060	LID/RING KIT 455mm	1
9	A300130	FILTER BASKET LARGE 254mm DEEP	1
10		not applicable	
11		not applicable	
12	HP-286	BRACKET, CABLE CONTROL	1
13	HP-289	MANIFOLD BRACKET A463CCR008A	1
14	HP-711A	FRONT TANK SUPPORT 4000LT	1
15		not applicable	
16	HP-704LA	SIDE RAIL L.H. 4000LT	1
17	HP-704RA	SIDE RAIL R.H. 4000LT	1
18	HP-715L	REAR LEFT TIE DOWN ROD	1
19	HP-715R	REAR RIGHT TIE DOWN ROD	1
20		not applicable	
21	HP-702A	STEP, RETRACTABLE 2000LT	1
22	HP-405	BRACKET FILTER SUCTION	1
23		not applicable	
24		not applicable	
25		not applicable	
26		not applicable	
27	KH-5000	QM500 9.8cc SINGLE SWIVEL	4
	KH-5002	QM380 6.5cc SINGLE SWIVEL	4

Pos	Part No	Description	Qty
28	HP-275C	CLAMP QUICK ADJUST	4
	HP-275C-1	CLAMP MOUNT PLATE QM500	4
	HP-275C-2	CLAMP MOUNT PLATE QM380	4
29	HP-283D	SUB FRAME QM 4000LT	1
30	HP-820	BRACKET HOOK TYPE 600mm x 600mm	2
31	HP-829	BRACKET HOOK TYPE 600mm X 1000mm	2
32	HP-274A-14G	CLAMP HALF SADDLE 90mm	6
33	HP-275-2	TOWER TUBE SINGLE ROW	2
34	HP-205A	AXLE ASSEMBLY SOLID POLY 4000LT	1
	HP-236CL	SUSPENSION SINGLE AXLE 4000LT (option)	1
	BP-400ADL	SUSPENSION TANDEM ASSEMBLY 4.4T 4000LT (option)	1
35	HP-202G	WHEEL/TYRE 400 X 15.5 LUG (option)	2
	HP-200	RIM/TYRE AWT 11.5/80-15.3 (tandem option only)	4
36	HP-024C	3 POINT LINKAGE SELF STEER DRAWBAR	1
37	BP-184	JOCKEY STAND (long)	1
38	HP-288	BRACKET MUDFLAP (tandem option only)	2
39	BP-180	MUDFLAP PLATE (tandem option only)	2
40	BP-542	MUDFLAP WHITE (tandem option only)	2
41	HP-006	SPIGOT PLATE JACK STAND	2



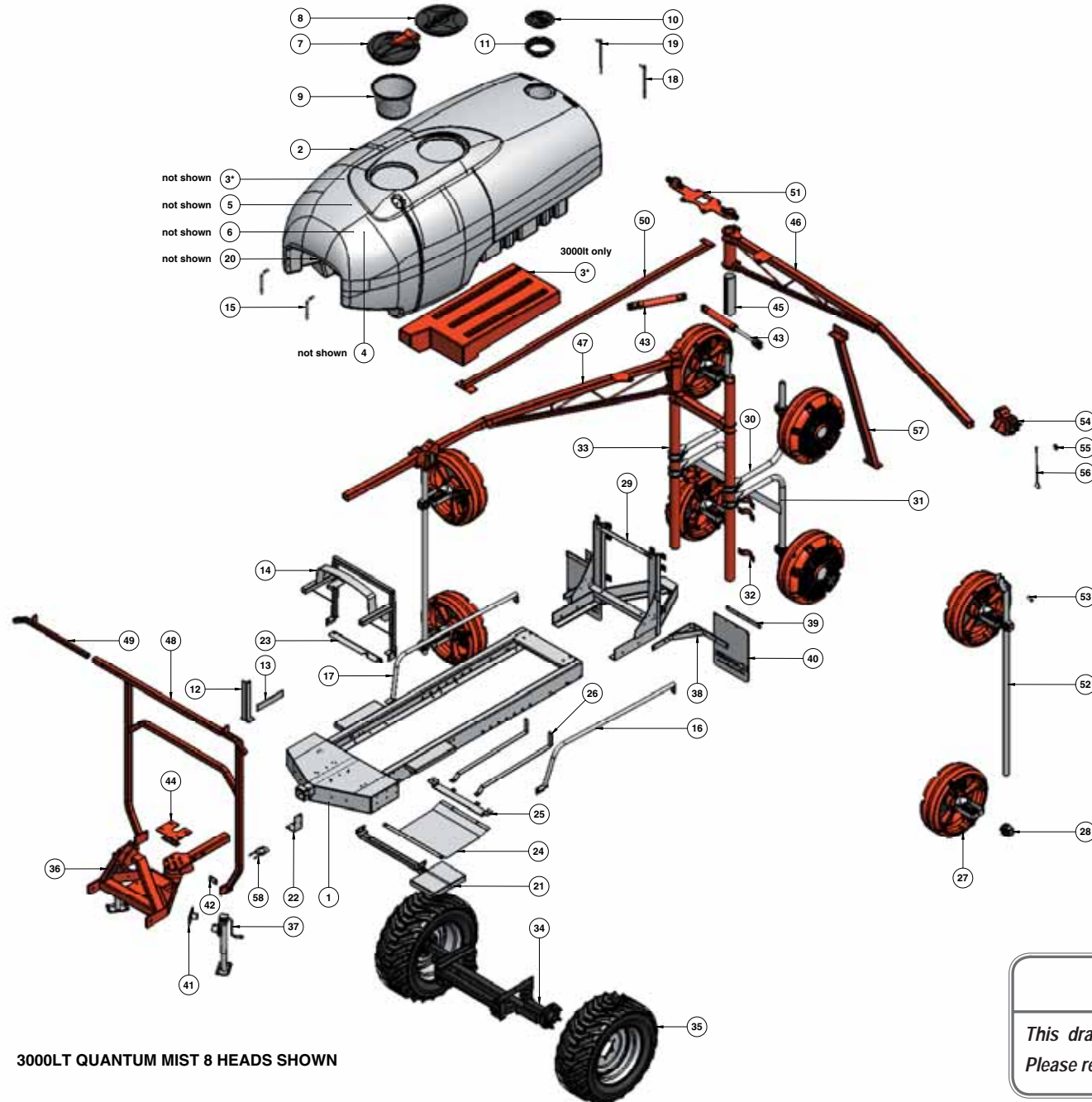

Pos	Part No	Description	Qty
1	HP1500AB	1500LT CHASSIS AIRBLAST	1
2	P1500AB	1500LT TANK POLY AIRBLAST RAW	1
3		120LT FLUSH TANK (not shown)	1
4		15LT HAND WASH TANK (not shown)	1
5		not applicable	
6	A354030	LID 4" complete with BREATHER & SEAL (not shown)	2
7	A356060	HINGED LID 180 degree 455mm	1
8	A3522040	LID/RING KIT 355mm	1
9	A300130	FILTER BASKET LARGE 254mm DEEP	1
10		not applicable	
11		not applicable	
12	HP-286	BRACKET, CABLE CONTROL	1
13	HP-289	MANIFOLD BRACKET A463CCR008A	1
14	HP-311	FRONT TANK SUPPORT 1500LT	1
15	HP-314	FRONT TIE DOWN ROD 1000/1500LT	2
16	HP-304L	SIDE RAIL L.H. 1500LT	1
17	HP-304R	SIDE RAIL R.H. 1500LT	1
18	HP-315L	REAR LEFT TIE DOWN ROD 1000/1500LT	1
19	HP-315R	REAR RIGHT TIE DOWN ROD 1000/1500LT	1
20		not applicable	
21	HP-402	STEP CROPLINER POLY 2000LT	1
22	HP-405	BRACKET FILTER SUCTION	1
23	HP-432	BRAGLIA VALVE BRACKET 2000LT	1
24		not applicable	1
25		not applicable	1
26		not applicable	2
27	KH-5000	QM500 9.8cc SINGLE SWIVEL	8
	KH-5002	QM380 6.5cc SINGLE SWIVEL	8
28	HP-275C	CLAMP QUICK ADJUST	8
	HP-275C-1	CLAMP MOUNT PLATE QM500	8
	HP-275C-2	CLAMP MOUNT PLATE QM380	8

Pos	Part No	Description	Qty
29	HP-274A-1A	SUB FRAME QM 1500LT	1
30	HP-820	BRACKET HOOK TYPE 600mm x 600mm	2
31	HP-829	BRACKET HOOK TYPE 600mm X 1000mm	2
32	HP-274A-14G	CLAMP HALF SADDLE 90mm	6
33	HP-274A-1A	SUB FRAME 1500LT	1
34	HP-236F	SUSPENSION ASSEMBLY POLY 2000LT	1
	HP-236A-1	SPACER for SUSPENSION ASSEMBLY (not shown)	2
35	HP-200	WHEEL/TYRE AWT 11.5/80-15.3	2
	HP-200A	WHEEL/TYRE AWT 10.5/75-15.3 (option)	2
36	HP-024C	3 POINT LINKAGE SELF STEER DRAWBAR	1
37	BP-184	JOCKEY STAND (long)	1
38		not applicable	
39		not applicable	
40		not applicable	
41	HP-006	SPIGOT PLATE JOCKEY STAND	1
42		not applicable	
43	HP-016	HYDRAULIC CYLINDER 2.0" X 10"	2
44	HP-024-1	PUMP MOUNT for 3PTL SELF STEER D/BAR	1
45	HP-268	BOOM SHIM 275 X 400 2mm thick	2
46	HP-274A-2D	BOOM ARM L.H. QM version 3 2000LT	1
47	HP-274A-3D	BOOM ARM R.H. QM version 3 2000LT	1
48	HP-274A-4A	PARKING BRACKET QM 1500LT	1
49	HP-274A-5	PARKING ARM	2
50	HP-274A-6A	TOP BRACE QM 1500LT	1
51	HP-274A-7	TOP BRACKET	1
52	HP-274A-10	DROPPER ARM OUTER	2
53	HP-274A-11	STEEL BUSH QM	2
54	HP-274A-12B	SWIVEL BRACKET ASSEMBLY version 3	2
55	HP-274A-16A	NYLON BUTTON 50 X 10	8
56	HP-274A-18	ACTUATOR ROD SWIVEL BRACKET	2
57		not applicable	
58		not applicable	

Pos	Part No	Description	Qty
1	HP2000ABA	2000LT CHASSIS AIRBLAST	1
2	P2000AAB-RAW	2000LT TANK POLY AIRBLAST RAW	1
3*	P2000AAB-130RAW	130LT FLUSH TANK (not shown)	1
4	P2000AAB-15RAW	15LT HAND WASH TANK (not shown)	1
5	A354010	LID 6" complete with BREATHER & SEAL (not shown)	1
6	A354030	LID 4" complete with BREATHER & SEAL (not shown)	1
7	A356060	HINGED LID 180 degree 455mm	1
8	A3522040	LID/RING KIT 355mm	1
9	A300130	FILTER BASKET LARGE 254mm DEEP	1
10		not applicable	
11		not applicable	
12	HP-286	BRACKET, CABLE CONTROL	1
13	HP-289	MANIFOLD BRACKET A463CCR008A	1
14	HP-411A	FRONT TANK SUPPORT 2000LT	1
15	HP-414	FRONT TIE DOWN ROD 2000LT	2
16	HP-404LA	SIDE RAIL L.H. 2000LT	1
17	HP-404RA	SIDE RAIL R.H. 2000LT	1
18	HP-415L	REAR LEFT TIE DOWN ROD	1
19	HP-415R	REAR RIGHT TIE DOWN ROD	1
20	HP-413	TANK SPREADER BAR 2000LT (not shown)	1
21	HP-402A	STEP, RETRACTABLE	1
22	HP-405	BRACKET FILTER SUCTION	1
23	HP-432	BRAGLIA VALVE BRACKET 2000LT	1
24		not applicable	
25		not applicable	
26		not applicable	
27	KH-5000	QM500 9.8cc SINGLE SWIVEL	8
	KH-5002	QM380 6.5cc SINGLE SWIVEL	8
28	HP-275C	CLAMP QUICK ADJUST	8
	HP-275C-1	CLAMP MOUNT PLATE QM500	8

Pos	Part No	Description	Qty
	HP-275C-2	CLAMP MOUNT PLATE QM380	8
29	HP-274A-1	SUB FRAME QM 2000LT	1
30	HP-820	BRACKET HOOK TYPE 600mm x 600mm	2
31	HP-829	BRACKET HOOK TYPE 600mm X 1000mm	2
32	HP-274A-14G	CLAMP HALF SADDLE 90mm	6
33	HP-275-2	TOWER TUBE SINGLE ROW	2
34	BP-400D	SUSPENSION TANDEM 2T 2000LT	1
	HP-236F	SUSPENSION ASSEMBLY POLY 2000LT (option)	1
35	HP-202	RIM/TYRE 10R X 15 LANDCRUISER	4
	HP-200	WHEEL/TYRE AWT 11.5/80-15.3 (option)	2
36	HP-024C	3 POINT LINKAGE SELF STEER DRAWBAR	1
37	BP-184	JOCKEY STAND (long)	1
38	HP-288	BRACKET MUDFLAP (tandem option only)	2
39	BP-180	MUDFLAP PLATE (tandem option only)	2
40	BP-542	MUDFLAP WHITE (tandem option only)	2
41	HP-006	SPIGOT PLATE JOCKEY STAND	1
42	BP-541	PLATE for 50mm U-BOLT	1
43	HP-016	HYDRAULIC CYLINDER 2.0" X 10"	2
44	HP-024-1	PUMP MOUNT for 3PTL SELF STEER D/BAR	1
45	HP-268	BOOM SHIM 275 X 400 2mm thick	2
46	HP-274A-2	BOOM ARM L.H. QM version 3 3000/4000LT	1
47	HP-274A-3	BOOM ARM R.H. QM version 3 3000/4000LT	1
48	HP-274A-4	PARKING BRACKET QM 2000LT	1
49	HP-274A-5	PARKING ARM	2
50	HP-274A-6	TOP BRACE QM version 2 3000LT	1
51	HP-274A-7	TOP BRACKET	1
52	HP-274A-10	DROPPER ARM OUTER	2
53	HP-274A-11	STEEL BUSH QM	2
54	HP-274A-12B	SWIVEL BRACKET ASSEMBLY version 3	2
55	HP-1274A-16A	NYLON BUTTON 50 X 10	8
56	HP-274A-18	ACTUATOR ROD SWIVEL BRACKET	2
57	HP-283D-1	not applicable	

Pos	Part No	Description	Qty
1	HP3000ABA	3000LT CHASSIS AIRBLAST version 2	1
2	P3000AB-RAW	3000LT TANK POLY AIRBLAST RAW	1
3*	P3000AB-110RAW	110LT FLUSH TANK	1
4		10LT HAND WASH TANK (integrated)	
5		not applicable	
6		not applicable	
7	A356060	HINGED LID 180 degree 455mm	1
8	A3510060	LID/RING KIT 455mm	1
9	A300130	FILTER BASKET LARGE 254mm DEEP	1
10	A3522120	LID 255MM CLOSED	1
11	A350620	LID RING WITH GASKET (3000LT only)	1
12	HP-286	BRACKET, CABLE CONTROL	1
13	HP-289	MANIFOLD BRACKET A463CCR008A	1
14	HP-511A	FRONT TANK SUPPORT 3000LT	1
15	HP-514	FRONT TIE DOWN ROD	2
16	HP-504LA	SIDE RAIL L.H. 3000LT	1
17	HP-504RA	SIDE RAIL R.H. 3000LT	1
18	HP-515L	REAR LEFT TIE DOWN ROD	1
19	HP-515R	REAR RIGHT TIE DOWN ROD	1
20		not applicable	
21	HP-402A	STEP, RETRACTABLE	1
22	HP-405	BRACKET FILTER SUCTION	1
23	HP-432A	BRAGLIA VALVE BRACKET 3000LT	1
24	HP-512	SUMP GUARD QM CHASSIS 3000LT	1
25	HP-520	CROSS RAIL BRACKET FLUSH TANK 3000LT	1
26	HP-521	SUPPORT STRAP FLUSH TANK 3000LT	2
27	KH-5000	QM500 9.8cc SINGLE SWIVEL	8
	KH-5002	QM380 6.5cc SINGLE SWIVEL	8
28	HP-275C	CLAMP QUICK ADJUST	8
	HP-275C-1	CLAMP MOUNT PLATE QM500	8
	HP-275C-2	CLAMP MOUNT PLATE QM380	8
29	HP-283E2	SUB FRAME QM 3000LT version 2	1

Pos	Part No	Description	Qty
30	HP-820	BRACKET HOOK TYPE 600mm x 600mm	2
31	HP-829	BRACKET HOOK TYPE 600mm X 1000mm	2
32	HP-274A-14G	CLAMP HALF SADDLE 90mm	6
33	HP-274A-15	MAIN TOWER ASSEMBLY	1
34	HP-236D	SUSPENSION SINGLE AXLE 3000LT	1
	BP-400JL	SUSPENSION TANDEM ASSEMBLY 3T 3000LT (option)	1
35	HP-202G	WHEEL/TYRE 400 X 15.5 LUG	2
	HP-200A	RIM/TYRE AWT 10.5/75-15.3 (tandem option only)	4
36	HP-024C	3 POINT LINKAGE SELF STEER DRAWBAR	1
37	BP-184	JOCKEY STAND (long)	2
38	HP-288	BRACKET MUDFLAP (tandem option only)	2
39	BP-180	MUDFLAP PLATE (tandem option only)	2
40	BP-542	MUDFLAP WHITE (tandem option only)	2
41	HP-006	SPIGOT PLATE JOCKEY STAND	2
42	BP-541	PLATE for 50mm U-BOLT	1
43	HP-016	HYDRAULIC CYLINDER 2.0" X 10"	2
44		not applicable	
45	HP-268	BOOM SHIM 275 X 400 2mm thick	2
46	HP-274A-2E	BOOM ARM L.H. QM version 3 3000/4000LT	1
47	HP-274A-3E	BOOM ARM R.H. QM version 3 3000/4000LT	1
48	HP-274A-4B1	PARKING BRACKET QM version 2 3000/4000LT	1
49	HP-274A-5	PARKING ARM	2
50	HP-274A-6D1	TOP BRACE QM version 2 3000LT	1
51	HP-274A-7	TOP BRACKET	1
52	HP-274A-10	DROPPER ARM OUTER	2
53	HP-274A-11	STEEL BUSH QM	2
54	HP-274A-12B	SWIVEL BRACKET ASSEMBLY version 3	2
55	HP-274A-16A	NYLON BUTTON 50 X 10	8
56	HP-274A-18	ACTUATOR ROD SWIVEL BRACKET	2
57	HP-283D-1	TOWER SUPPORT BRACKET QM	1
58	HP-434	BRACKET DAM FILL HORT 3000/4000LT	1



Pos	Part No	Description	Qty
1	HP4000ABA	4000LT CHASSIS AIRBLAST	1
2	P4000AB-RAW	4000LT TANK POLY AIRBLAST RAW	1
3*		80LT FLUSH TANK (integrated)	1
4		not applicable	
5		not applicable	
6		not applicable	
7	A356060	HINGED LID 180 degree 455mm	1
8	A3510060	LID/RING KIT 455mm	1
9	A300130	FILTER BASKET LARGE 254mm DEEP	1
10		not applicable	
11		not applicable	
12	HP-286	BRACKET, CABLE CONTROL	1
13	HP-289	MANIFOLD BRACKET A463CCR008A	1
14	HP-711A	FRONT TANK SUPPORT 4000LT	1
15		not applicable	
16	HP-704LA	SIDE RAIL L.H. 4000LT	1
17	HP-704RA	SIDE RAIL R.H. 4000LT	1
18	HP-715L	REAR LEFT TIE DOWN ROD	1
19	HP-715R	REAR RIGHT TIE DOWN ROD	1
20		not applicable	
21	HP-702A	STEP, RETRACTABLE 2000LT	1
22	HP-405	BRACKET FILTER SUCTION	1
23		not applicable	
24		not applicable	
25		not applicable	
26		not applicable	
27	KH-5000	QM500 9.8cc SINGLE SWIVEL	8
	KH-5002	QM380 6.5cc SINGLE SWIVEL	8
28	HP-275C	CLAMP QUICK ADJUST	8
	HP-275C-1	CLAMP MOUNT PLATE QM500	8
	HP-275C-2	CLAMP MOUNT PLATE QM380	8
29	HP-283D	SUB FRAME QM 4000LT	1

Pos	Part No	Description	Qty
30	HP-820	BRACKET HOOK TYPE 600mm x 600mm	2
31	HP-829	BRACKET HOOK TYPE 600mm X 1000mm	2
32	HP-274A-14G	CLAMP HALF SADDLE 90mm	6
33	HP-274A-15	MAIN TOWER ASSEMBLY	1
34	HP-236CL	SUSPENSION SINGLE AXLE 4000LT	1
	BP-400ADL	SUSPENSION TANDEM ASSEMBLY 4.4T 4000LT (option)	1
35	HP-202G	WHEEL/TYRE 400 X 15.5 LUG	2
	HP-200	RIM/TYRE AWT 11.5/80-15.3 (tandem option only)	4
36	HP-024C	3 POINT LINKAGE SELF STEER DRAWBAR	1
37	BP-184	JOCKEY STAND (long)	2
38	HP-288	BRACKET MUDFLAP (tandem option only)	2
39	BP-180	MUDFLAP PLATE (tandem option only)	2
40	BP-542	MUDFLAP WHITE (tandem option only)	2
41	HP-006	SPIGOT PLATE JOCKEY STAND	2
42	BP-541	PLATE for 50mm U-BOLT	1
43	HP-016	HYDRAULIC CYLINDER 2.0" X 10"	2
44		not applicable	
45	HP-268	BOOM SHIM 275 X 400 2mm thick	2
46	HP-274A-2E	BOOM ARM L.H. QM version 3 3000/4000LT	1
47	HP-274A-3E	BOOM ARM R.H. QM version 3 3000/4000LT	1
48	HP-274A-4B1	PARKING BRACKET QM version 2 3000/4000LT	1
49	HP-274A-5	PARKING ARM	2
50	HP-274A-6B1	TOP BRACE QM version 2 4000LT	1
51	HP-274A-7	TOP BRACKET	1
52	HP-274A-10	DROPPER ARM OUTER	2
53	HP-274A-11	STEEL BUSH QM	2
54	HP-274A-12B	SWIVEL BRACKET ASSEMBLY version 3	2
55	HP-274A-16A	NYLON BUTTON 50 X 10	8
56	HP-274A-18	ACTUATOR ROD SWIVEL BRACKET	2
57	HP-283D-1	TOWER SUPPORT BRACKET QM	1
58	HP-434	BRACKET DAM FILL HORT 3000/4000LT	1

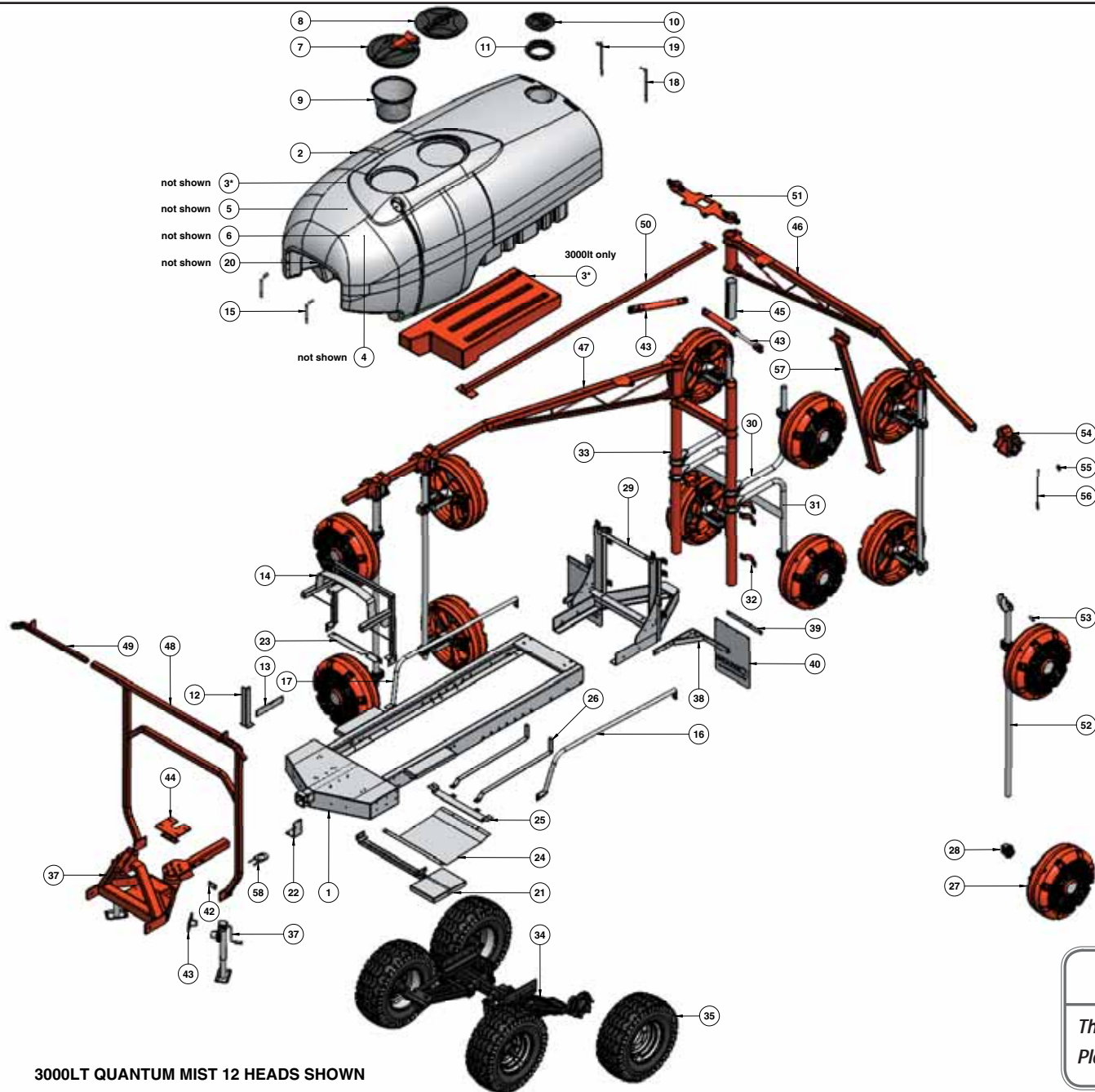

3000LT QUANTUM MIST 12 HEADS SHOWN

**NOTE**  
 This drawing is for illustration purposes only.  
 Please refer to the parts list.

Pos	Part No	Description	Qty
1	HP3000ABA	3000LT CHASSIS AIRBLAST version 2	1
2	P3000AB-RAW	3000LT TANK POLY AIRBLAST RAW	1
3	P3000AB-110RAW	110LT FLUSH TANK	1
4		10LT HAND WASH TANK (integrated)	
5		not applicable	
6		not applicable	
7	A356060	HINGED LID 180 degree 455mm	1
8	A3510060	LID/RING KIT 455mm	1
9	A300130	FILTER BASKET LARGE 254mm DEEP	1
10	A3522120	LID 255MM CLOSED	1
11	A350620	LID RING WITH GASKET (3000lt only)	1
12	HP-286	BRACKET, CABLE CONTROL	1
13	HP-289	MANIFOLD BRACKET A463CCR008A	1
14	HP-511A	FRONT TANK SUPPORT 3000LT	1
15	HP-514	FRONT TIE DOWN ROD	2
16	HP-504LA	SIDE RAIL L.H. 3000LT	1
17	HP-504RA	SIDE RAIL R.H. 3000LT	1
18	HP-515L	REAR LEFT TIE DOWN ROD	1
19	HP-515R	REAR RIGHT TIE DOWN ROD	1
20		not applicable	
21	HP-402A	STEP, RETRACTABLE	1
22	HP-405	BRACKET FILTER SUCTION	1
23	HP-432A	BRAGLIA VALVE BRACKET 3000LT	1
24	HP-512	SUMP GUARD QM CHASSIS 3000LT	1
25	HP-520	CROSS RAIL BRACKET FLUSH TANK 3000LT	1
26	HP-521	SUPPORT STRAP FLUSH TANK 3000LT	2
27	KH-5000	QM500 9.8cc SINGLE SWIVEL	12
	KH-5002	QM380 6.5cc SINGLE SWIVEL	12
28	HP-275C	CLAMP QUICK ADJUST	12
	HP-275C-1	CLAMP MOUNT PLATE QM500	12
	HP-275C-2	CLAMP MOUNT PLATE QM380	12
29	HP-283E2	SUB FRAME QM 3000LT version 2	1

Pos	Part No	Description	Qty
30	HP-820	BRACKET HOOK TYPE 600mm x 600mm	2
31	HP-829	BRACKET HOOK TYPE 600mm X 1000mm	2
32	HP-274A-14G	CLAMP HALF SADDLE 90mm	6
33	HP-274A-15	MAIN TOWER ASSEMBLY 1500/2000LT	1
34	BP-400JL	SUSPENSION TANDEM ASSEMBLY 3T 3000LT	1
35	HP-200A	RIM/TYRE AWT 10.5/75-15.3	4
36	HP-024C	3 POINT LINKAGE SELF STEER DRAWBAR	1
37	BP-184	JOCKEY STAND (long)	2
38	HP-288	BRACKET MUDFLAP	2
39	BP-180	MUDFLAP PLATE	2
40	BP-542	MUDFLAP WHITE	2
41	HP-006	SPIGOT PLATE JOCKEY STAND	2
42	BP-541	PLATE for 50mm U-BOLT	1
43	HP-016	HYDRAULIC CYLINDER 2.0" X 10"	2
44		not applicable	
45	HP-268	BOOM SHIM 275 X 400 2mm thick	2
46	HP-274A-2E	BOOM ARM L.H. QM version 3 3000/4000LT	1
47	HP-274A-3E	BOOM ARM R.H. QM version 3 3000/4000LT	1
48	HP-274A-4B1	PARKING BRACKET QM version 2 3000/4000LT	1
49	HP-274A-5	PARKING ARM	2
50	HP-274A-6D1	TOP BRACE QM version 2 3000LT	1
51	HP-274A-7	TOP BRACKET	1
52	HP-274A-10	DROPPER ARM OUTER	4
53	HP-274A-11	STEEL BUSH QM	4
54	HP-274A-12B	SWIVEL BRACKET ASSEMBLY version 3	4
55	HP-274A-16A	NYLON BUTTON 50 X 10	16
56	HP-274A-18	ACTUATOR ROD SWIVEL BRACKET	4
57	HP-283D-1	TOWER SUPPORT BRACKET QM	1
58	HP-434	BRACKET DAM FILL HORT 3000/4000LT	1

Pos	Part No	Description	Qty
1	HP4000ABA	4000LT CHASSIS AIRBLAST	1
2	P4000AB-RAW	4000LT TANK POLY AIRBLAST RAW	1
3*		80LT FLUSH TANK (integrated)	1
4		not applicable	
5		not applicable	
6		not applicable	
7	A356060	HINGED LID 180 degree 455mm	1
8	A3510060	LID/RING KIT 455mm	1
9	A300130	FILTER BASKET LARGE 254mm DEEP	1
10		not applicable	
11		not applicable	
12	HP-286	BRACKET, CABLE CONTROL	1
13	HP-289	MANIFOLD BRACKET A463CCR008A	1
14	HP-711A	FRONT TANK SUPPORT 4000LT	1
15		not applicable	
16	HP-704LA	SIDE RAIL L.H. 4000LT	1
17	HP-704RA	SIDE RAIL R.H. 4000LT	1
18	HP-715L	REAR LEFT TIE DOWN ROD	1
19	HP-715R	REAR RIGHT TIE DOWN ROD	1
20		not applicable	
21	HP-702A	STEP, RETRACTABLE	1
22	HP-405	BRACKET FILTER SUCTION	1
23		not applicable	
24		not applicable	
25		not applicable	
26		not applicable	
27	KH-5000	QM500 9.8cc SINGLE SWIVEL	12
	KH-5002	QM380 6.5cc SINGLE SWIVEL	12
28	HP-275C	CLAMP QUICK ADJUST	12
	HP-275C-1	CLAMP MOUNT PLATE QM500	12
	HP-275C-2	CLAMP MOUNT PLATE QM380	12
29	HP-283D	SUB FRAME QM 4000LT	1

Pos	Part No	Description	Qty
30	HP-820	BRACKET HOOK TYPE 600mm x 600mm	2
31	HP-829	BRACKET HOOK TYPE 600mm X 1000mm	2
32	HP-274A-14G	CLAMP HALF SADDLE 90mm	6
33	HP-274A-15	MAIN TOWER ASSEMBLY 1500/2000LT	1
34	BP-400ADL	SUSPENSION TANDEM ASSEMBLY 4.4T 4000LT	1
35	HP-200	RIM/TYRE AWT 11.5/80-15.3	4
36	HP-024C	3 POINT LINKAGE SELF STEER DRAWBAR	1
37	BP-184	JOCKEY STAND (long)	1
38	HP-288	BRACKET MUDFLAP	2
39	BP-180	MUDFLAP PLATE	2
40	BP-542	MUDFLAP WHITE	2
41	HP-006	SPIGOT PLATE JOCKEY STAND	1
42	BP-541	PLATE for 50mm U-BOLT	1
43	HP-016	HYDRAULIC CYLINDER 2.0" X 10"	2
44	HP-024-1	PUMP MOUNT for 3PTL SELF STEER D/BAR	1
45	HP-268	BOOM SHIM 275 X 400 2mm thick	2
46	HP-274A-2E	BOOM ARM L.H. QM version 3 3000/4000LT	1
47	HP-274A-3E	BOOM ARM R.H. QM version 3 3000/4000LT	1
48	HP-274A-4B1	PARKING BRACKET QM version 2 3000/4000LT	1
49	HP-274A-5	PARKING ARM	2
50	HP-274A-6B1	TOP BRACE QM version 2 4000LT	1
51	HP-274A-7	TOP BRACKET	1
52	HP-274A-10	DROPPER ARM OUTER	4
53	HP-274A-11	STEEL BUSH QM	4
54	HP-274A-12B	SWIVEL BRACKET ASSEMBLY version 3	4
55	HP-274A-16A	NYLON BUTTON 50 X 10	16
56	HP-274A-18	ACTUATOR ROD SWIVEL BRACKET	4
57	HP-283D-1	TOWER SUPPORT BRACKET QM	1
58	HP-434	BRACKET DAM FILL HORT 3000/4000LT	1



## PART NO: HP-198B 1500L/2000L XL ADJUSTABLE SOLID SINGLE AXLE

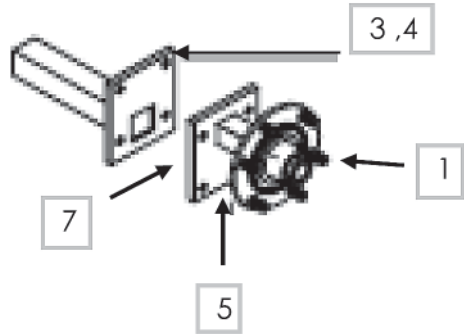

## PART NO: HP-199F STUB AXLE

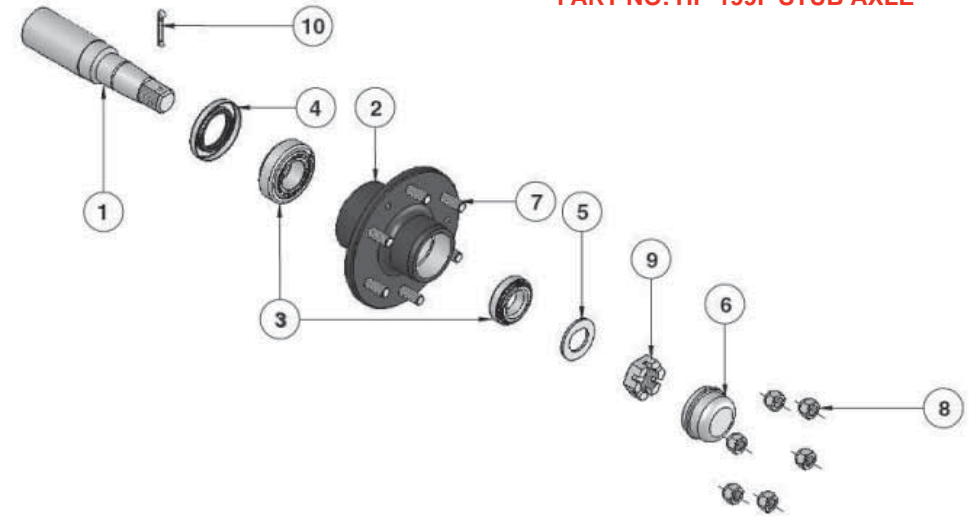

Pos	Part No	Description	Qty
1	HP-199F	STUB AXLE 6STUD 75MM SQUARE	2
2	HP-309	AXLE HOUSING 1500L (not shown)	1
2A	HP-409	AXLE HOUSING 2000L (not shown)	1
3	HP-408L	AXLE ADJUSTABLE LEFT HAND	1
4	HP-408R	AXLE ADJUSTABLE RIGH THAND	1
5	HP-198B	STUB AXLE / PLATE ASSEMBLY	2
6	MT10013	SPEED SENSOR MOUNTING BRACKET (not shown)	1
7	HP-201	PLATE	2

Pos	Part No	Description	Qty
1	<i>HP-199F-1</i>	<i>STUB 50SQ x 338LG</i>	
2	<i>HP-199F-2</i>	<i>HUB DRILLED 6/205PCD</i>	
3	<i>HP-199F-3</i>	<i>BEARING KIT 32209/32206</i>	
4	<i>HP-199F-4</i>	<i>SEAL M85 x 54 x 10</i>	
4a	<i>HP-199F-4A</i>	<i>SEAL RING M46 x 54 x 13 (not shown)</i>	
5	<i>HP-199F-5</i>	<i>FLAT WASHER 1 1/8"</i>	
6	<i>HP-199F-6</i>	<i>DUST CAP (3 screws items 11 &amp; 12)</i>	
7	<i>HP-199F-7</i>	<i>WHEEL STUD M18 x 1.5 x 65</i>	
8	<i>HP-199F-8</i>	<i>WHEEL NUT M18 x 1.5</i>	
9	<i>HP-199F-9</i>	<i>SLOTTED NUT M27 x 2</i>	
10	<i>HP-199F-10</i>	<i>SPLIT PIN M5 x 50</i>	
11	<i>HP-199F-11</i>	<i>SOCKET HEAD CAP SCREW M6 x 30 (not shown)</i>	
12	<i>HP-199F-12</i>	<i>RIB LOCK WASHER M6 (not shown)</i>	

### NOTE

*Drawing are for illustration purposes only.  
Please refer to the parts list.*

### NOTE

*Parts in Italics are non-stocked items and may need to be ordered.*

## PART NO: BP-205DA 1500L/2000L SOLID AXLE

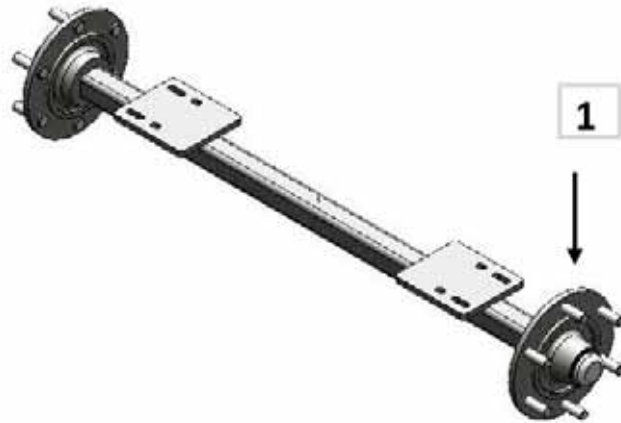

## PART NO: HP-199F STUB AXLE

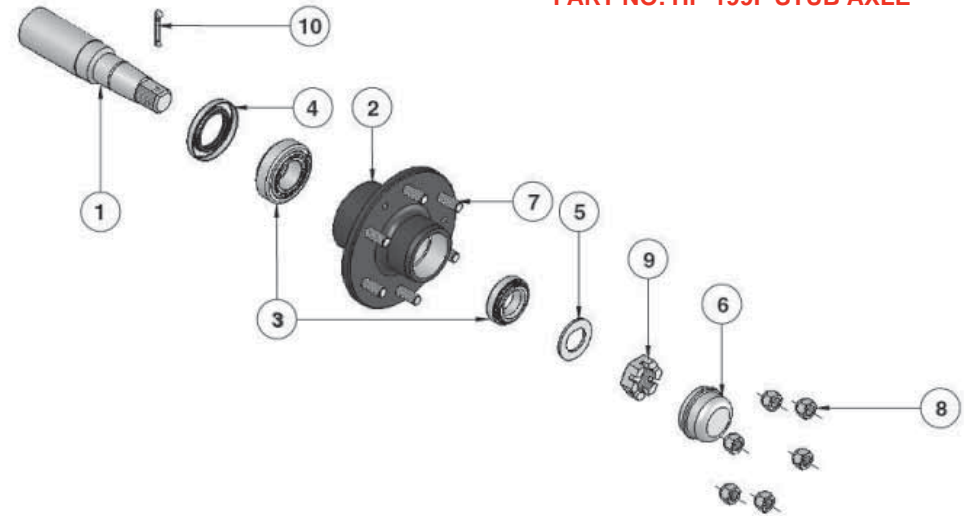

Pos	Part No	Description	Qty
1	HP-199F	AXLE/HUB 6/205 50SQ ANDYS	2
2	HP-205D-1	AXLE BRACKET (not shown)	2
3	MT10013	SPEED SENSOR MOUNTING BRACKET (not shown)	1

Pos	Part No	Description	Qty
1	<i>HP-199F-1</i>	<i>STUB 50SQ x 338LG</i>	
2	<i>HP-199F-2</i>	<i>HUB DRILLED 6/205PCD</i>	
3	<i>HP-199F-3</i>	<i>BEARING KIT 32209/32206</i>	
4	<i>HP-199F-4</i>	<i>SEAL M85 x 54 x 10</i>	
4a	<i>HP-199F-4A</i>	<i>SEAL RING M46 x 54 x 13 (not shown)</i>	
5	<i>HP-199F-5</i>	<i>FLAT WASHER 1 1/8"</i>	
6	<i>HP-199F-6</i>	<i>DUST CAP (3 screws items 11 &amp; 12)</i>	
7	<i>HP-199F-7</i>	<i>WHEEL STUD M18 x 1.5 x 65</i>	
8	<i>HP-199F-8</i>	<i>WHEEL NUT M18 x 1.5</i>	
9	<i>HP-199F-9</i>	<i>SLOTTED NUT M27 x 2</i>	
10	<i>HP-199F-10</i>	<i>SPLIT PIN M5 x 50</i>	
11	<i>HP-199F-11</i>	<i>SOCKET HEAD CAP SCREW M6 x 30 (not shown)</i>	
12	<i>HP-199F-12</i>	<i>RIB LOCK WASHER M6 (not shown)</i>	

### NOTE

*Drawing are for illustration purposes only.  
Please refer to the parts list.*

### NOTE

*Parts in Italics are non-stocked items and may need to be ordered.*

## PART NO: BP-205A 3000L SOLID AXLE

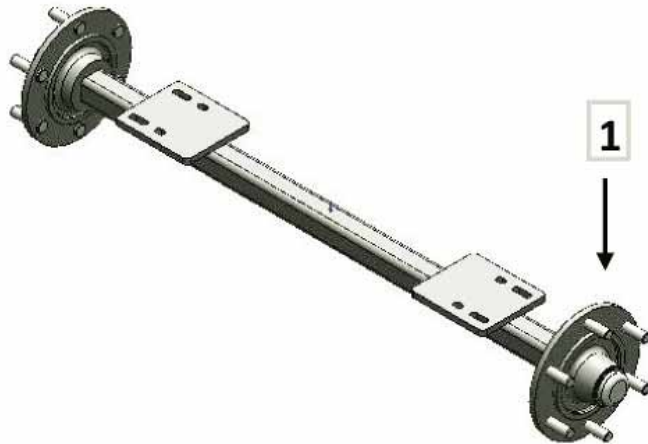

## PART NO: HP-199E STUB AXLE

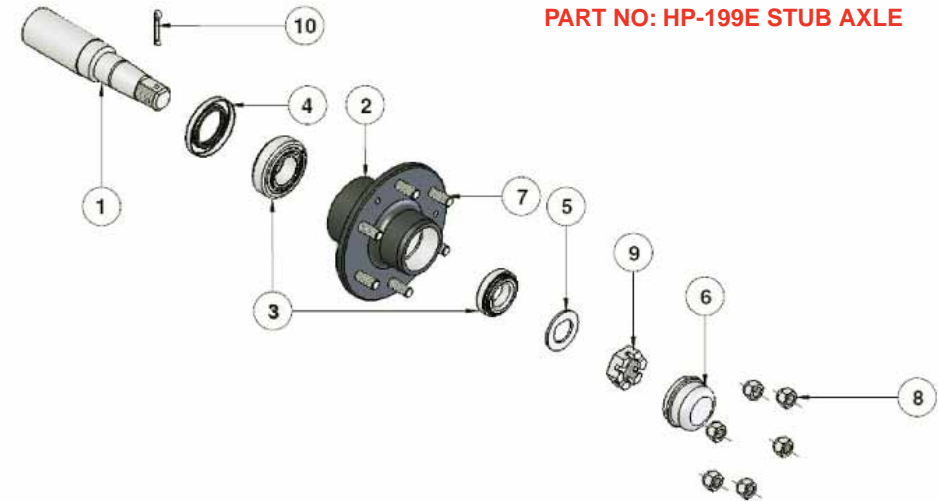

Pos	Part No	Description	Qty
1	HP-199E	AXLE/HUB 6/205 50SQ ANDYS	2
2	MT10013	SPEED SENSOR MOUNTING BRACKET (not shown)	1

Pos	Part No	Description	Qty
1	<i>HP-199E-1</i>	<i>STUB 85SQ x 395LG</i>	
2	<i>HP-199E-2</i>	<i>WHEELHUB 6/205 PCD</i>	
3	HP-199E-3	BEARING KIT 32213/32210	
4	HP-199E-4	TRIPLE LIP SEAL 125 x 90 x 12mm	
4	<i>HP-199E-4A</i>	<i>SEAL RING 70.5x90x16.5mm (not shown)</i>	
4	<i>HP-199E-4B</i>	<i>WEAR RING (to suit T.L.S [not shown])</i>	
5	N/A	N/A	
6	<i>HP-199E-6</i>	<i>DUST CAP (3 screws items 11 and 12)</i>	
7	HP-199E-7	WHEEL STUD M18 x 1.5 x 65	
8	HP-199E-8	WHEEL NUT M18 x 1.5	
9	<i>HP-199E-9</i>	<i>SLOTTED/CASTLE NUT M39 x 2</i>	
10	<i>HP-199E-10</i>	<i>SPLIT PIN 60 x 6mm</i>	
11	<i>HP-199E-11</i>	<i>SOCKET HEAD CAP SCREW M8 x 30 (not shown)</i>	
12	<i>HP-199E-12</i>	<i>M8 RIB LOCK WASHERS (not shown)</i>	

### NOTE

*Drawing are for illustration purposes only.  
Please refer to the parts list.*

### NOTE

*Parts in Italics are non-stocked items and may need to be ordered.*

## PART NO: BP-205B 4000L SOLID AXLE

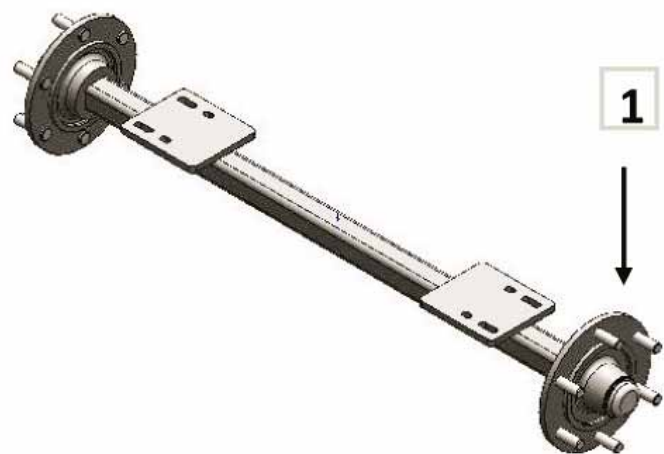

## PART NO: HP-199E STUB AXLE

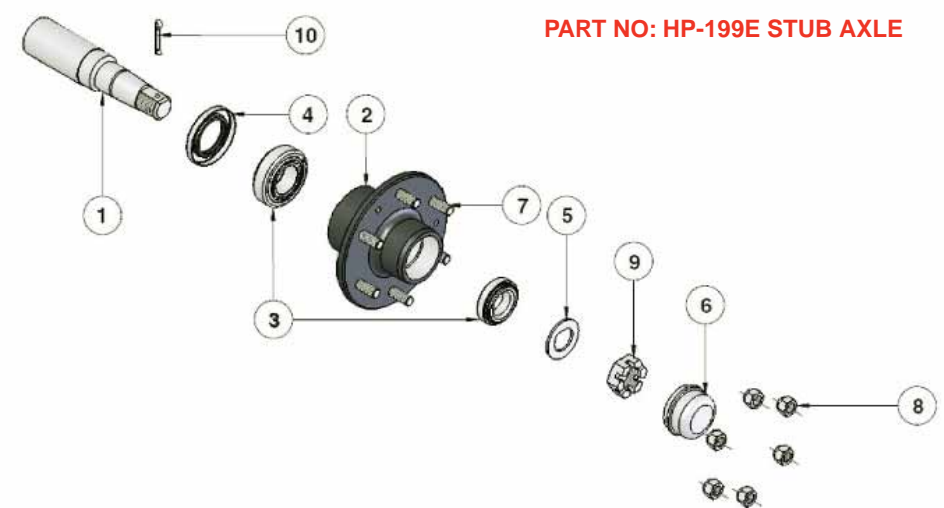

Pos	Part No	Description	Qty
1	HP-199F	AXLE/HUB 6/205 50SQ ANDYS	2
2	HP-205D-1	AXLE BRACKET (not shown)	2
3	MT10013	SPEED SENSOR MOUNTING BRACKET (not shown)	1

**NOTE**

*Drawing are for illustration purposes only.  
Please refer to the parts list.*

**NOTE**

*Parts in Italics are non-stocked items and may need to be ordered.*

Pos	Part No	Description	Qty
1	<i>HP-199E-1</i>	<i>STUB 85SQ x 395LG</i>	
2	<i>HP-199E-2</i>	<i>WHEELHUB 6/205 PCD</i>	
3	HP-199E-3	BEARING KIT 32213/32210	
4	HP-199E-4	TRIPLE LIP SEAL 125 x 90 x 12mm	
4	<i>HP-199E-4A</i>	<i>SEAL RING 70.5x90x16.5mm (not shown)</i>	
4	<i>HP-199E-4B</i>	<i>WEAR RING (to suit T.L.S [not shown])</i>	
5	N/A	N/A	
6	<i>HP-199E-6</i>	<i>DUST CAP (3 screws items 11 and 12)</i>	
7	HP-199E-7	WHEEL STUD M18 x 1.5 x 65	
8	HP-199E-8	WHEEL NUT M18 x 1.5	
9	<i>HP-199E-9</i>	<i>SLOTTED/CASTLE NUT M39 x 2</i>	
10	<i>HP-199E-10</i>	<i>SPLIT PIN 60 x 6mm</i>	
11	<i>HP-199E-11</i>	<i>SOCKET HEAD CAP SCREW M8 x 30 (not shown)</i>	
12	<i>HP-199E-12</i>	<i>M8 RIB LOCK WASHERS (not shown)</i>	



## PART NO: BP-236F 1500L/2000L SUSPENSION SINGLE AXLE

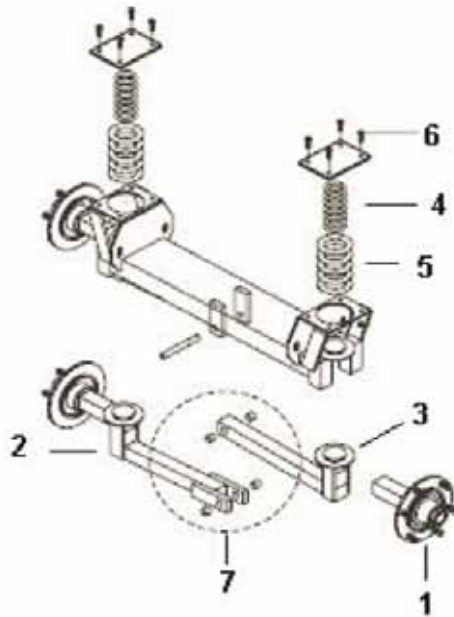

## PART NO: HP-199F STUB AXLE

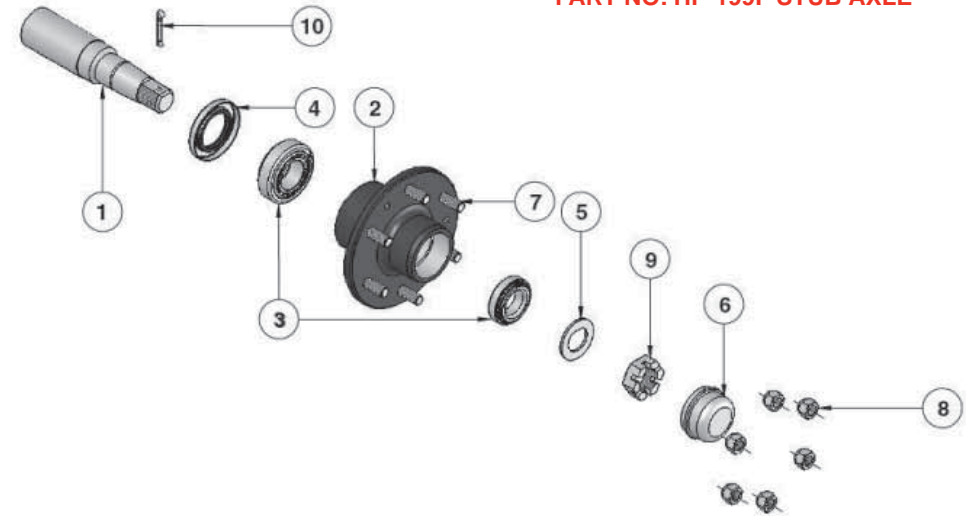

Pos	Part No	Description	Qty
1	HP-199F	STUB AXLE 6STUD 75MM SQUARE	2
2	HP-236ARMC	SUSPENSION ARM (CLEVIS)	1
3	HP-236ARMT	SUSPENSION ARM (TANG)	1
4	HP-271A	SPRING INNER (SMALL)	2
5	HP-271	SPRING OUTER (LARGE)	2
6	XCON	BOLTS M12x35	8
7	HP-236A-2	BRASS BUSH	8
8	HP-236A-1	SPACER FOR 1500L (not shown)	1
9	MT10013	SPEED SENSOR MOUNTING BRACKET (not shown)	1

Pos	Part No	Description	Qty
1	<i>HP-199F-1</i>	<i>STUB 50SQ x 338LG</i>	
2	<i>HP-199F-2</i>	<i>HUB DRILLED 6/205PCD</i>	
3	<i>HP-199F-3</i>	<i>BEARING KIT 32209/32206</i>	
4	<i>HP-199F-4</i>	<i>SEAL M85 x 54 x 10</i>	
4a	<i>HP-199F-4A</i>	<i>SEAL RING M46 x 54 x 13 (not shown)</i>	
5	<i>HP-199F-5</i>	<i>FLAT WASHER 1 1/8"</i>	
6	<i>HP-199F-6</i>	<i>DUST CAP (3 screws items 11 &amp; 12)</i>	
7	<i>HP-199F-7</i>	<i>WHEEL STUD M18 x 1.5 x 65</i>	
8	<i>HP-199F-8</i>	<i>WHEEL NUT M18 x 1.5</i>	
9	<i>HP-199F-9</i>	<i>SLOTTED NUT M27 x 2</i>	
10	<i>HP-199F-10</i>	<i>SPLIT PIN M5 x 50</i>	
11	<i>HP-199F-11</i>	<i>SOCKET HEAD CAP SCREW M6 x 30 (not shown)</i>	
12	<i>HP-199F-12</i>	<i>RIB LOCK WASHER M6 (not shown)</i>	

### NOTE

*Drawing are for illustration purposes only.  
Please refer to the parts list.*

### NOTE

*Parts in Italics are non-stocked items and may need to be ordered.*

## PART NO: HP-236D 3000L SUSPENSION SINGLE AXLE

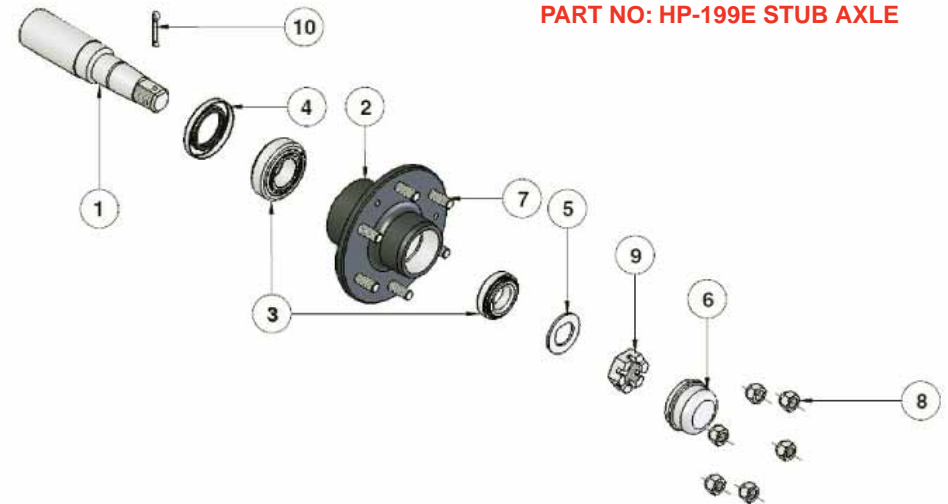
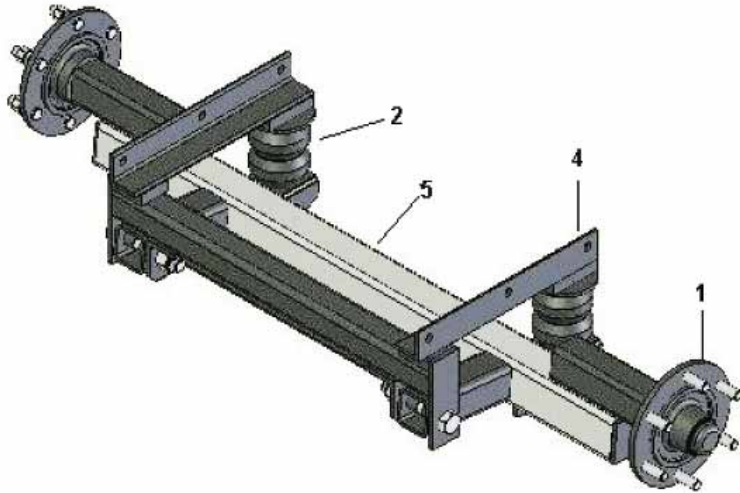

## PART NO: HP-199E STUB AXLE

Pos	Part No	Description	Qty
1	HP-199E	STUB AXLE 6STUD 75MM SQUARE	2
2	HP-236CL-1A	RUBBER SPRING A560-65	2
3	HP-236CLA-1A-1	BUSH 32x13.5X22.5 (not shown)	2
4	HP-236D-1	AXLE HOUSING	1
5	HP-236D-2	AXLE BEAM	1
6	MT10013	SPEED SENSOR MOUNTING BRACKET (not shown)	1

Pos	Part No	Description	Qty
1	<i>HP-199E-1</i>	<i>STUB 85SQ x 395LG</i>	
2	<i>HP-199E-2</i>	<i>WHEELHUB 6/205 PCD</i>	
3	HP-199E-3	BEARING KIT 32213/32210	
4	HP-199E-4	TRIPLE LIP SEAL 125 x 90 x 12mm	
4	<i>HP-199E-4A</i>	<i>SEAL RING 70.5x90x16.5mm (not shown)</i>	
4	<i>HP-199E-4B</i>	<i>WEAR RING (to suit T.L.S [not shown])</i>	
5	<i>N/A</i>	<i>N/A</i>	
6	<i>HP-199E-6</i>	<i>DUST CAP (3 screws items 11 and 12)</i>	
7	HP-199E-7	WHEEL STUD M18 x 1.5 x 65	
8	HP-199E-8	WHEEL NUT M18 x 1.5	
9	<i>HP-199E-9</i>	<i>SLOTTED/CASTLE NUT M39 x 2</i>	
10	<i>HP-199E-10</i>	<i>SPLIT PIN 60 x 6mm</i>	
11	<i>HP-199E-11</i>	<i>SOCKET HEAD CAP SCREW M8 x 30 (not shown)</i>	
12	<i>HP-199E-12</i>	<i>M8 RIB LOCK WASHERS (not shown)</i>	

### NOTE

*Drawing are for illustration purposes only.  
Please refer to the parts list.*

### NOTE

*Parts in Italics are non-stocked items and may need to be ordered.*

## PART NO: HP-236CLA 4000L SUSPENSION SINGLE AXLE

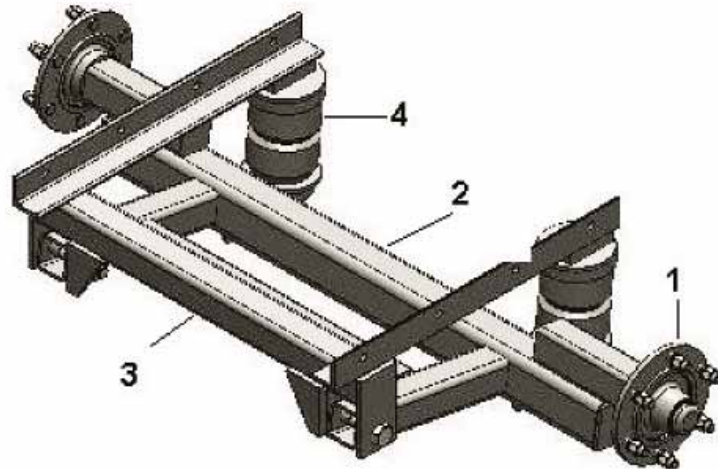

## PART NO: HP-199E STUB AXLE

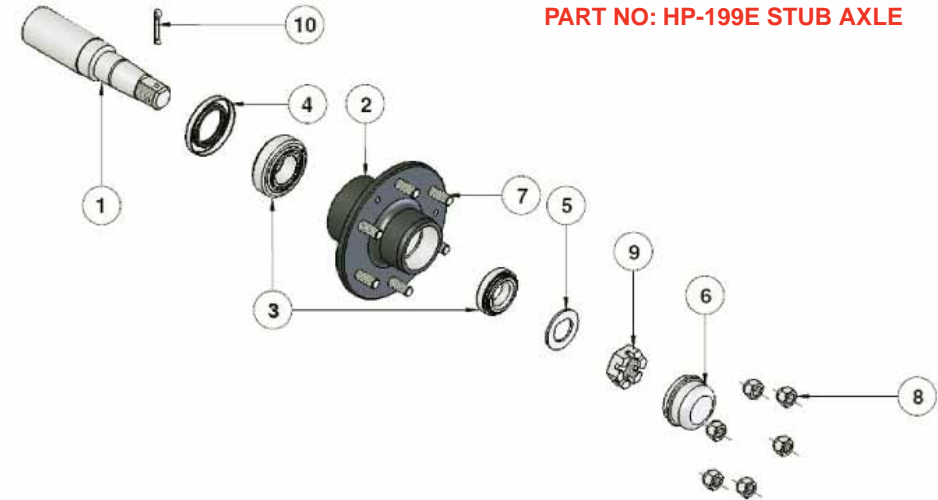

Pos	Part No	Description	Qty
1	HP-199E	STUB AXLE 6STUD 75MM SQUARE	2
2	HP-236CLA-2	AXLE BEAM	1
3	HP-236CLA-1	AXLE HOUSING	1
4	HP-236CL-1A	RUBBER SPRING A560-65	2
5	HP-236CL-1A-1	BUSH 32x13.5X22.5 (not shown)	2
6	MT10013	SPEED SENSOR MOUNTING BRACKET (not shown)	1

Pos	Part No	Description	Qty
1	<i>HP-199E-1</i>	<i>STUB 85SQ x 395LG</i>	
2	<i>HP-199E-2</i>	<i>WHEELHUB 6/205 PCD</i>	
3	HP-199E-3	BEARING KIT 32213/32210	
4	HP-199E-4	TRIPLE LIP SEAL 125 x 90 x 12mm	
4	<i>HP-199E-4A</i>	<i>SEAL RING 70.5x90x16.5mm (not shown)</i>	
4	<i>HP-199E-4B</i>	<i>WEAR RING (to suit T.L.S [not shown])</i>	
5	<i>N/A</i>	<i>N/A</i>	
6	<i>HP-199E-6</i>	<i>DUST CAP (3 screws items 11 and 12)</i>	
7	HP-199E-7	WHEEL STUD M18 x 1.5 x 65	
8	HP-199E-8	WHEEL NUT M18 x 1.5	
9	<i>HP-199E-9</i>	<i>SLOTTED/CASTLE NUT M39 x 2</i>	
10	<i>HP-199E-10</i>	<i>SPLIT PIN 60 x 6mm</i>	
11	<i>HP-199E-11</i>	<i>SOCKET HEAD CAP SCREW M8 x 30 (not shown)</i>	
12	<i>HP-199E-12</i>	<i>M8 RIB LOCK WASHERS (not shown)</i>	

### NOTE

*Drawing are for illustration purposes only.  
Please refer to the parts list.*

### NOTE

*Parts in Italics are non-stocked items and may need to be ordered.*

## PART NO: BP-400D 2000L SUSPENSION TANDEM AXLE

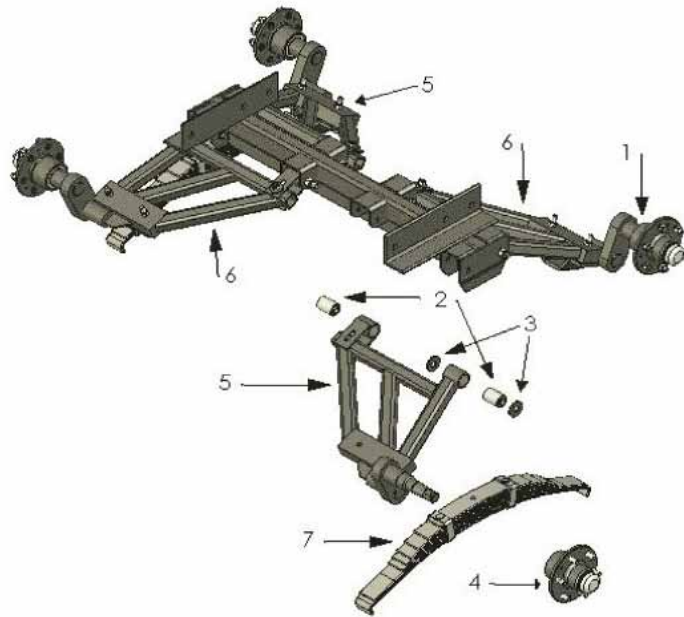

## PART NO: BP-400D STUB AXLE

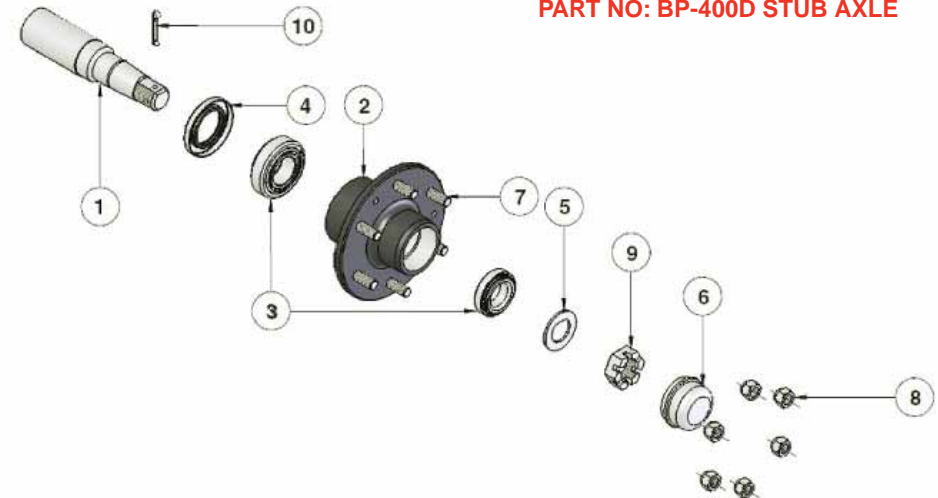

Pos	Part No	Description	Qty
1	BP-400DSTUB	STUB AXLE A75 (Stub and Hub)	4
2	BP-400-2	PIVOT BUSH TRAILING ARM 5/8"	8
3	BP-400-3	THRUST WASHER	4
4	BP-400-4	HUB COMPLETE (Bearings, Seal & Dust Cap)	4
5	<i>BP-400-5</i>	<i>TRAILING ARM LEFT FRONT / RIGHT BACK</i>	2
6	<i>BP-400-6</i>	<i>TRAILING ARM RIGHT FRONT/LEFT BACK</i>	2
7	BP-400DSPRING	SPRING ASSEMBLY	2
7a	BP-400SPRING	Heavy Duty Spring Assy (optional spare part)	
8	MT10013	SPEED SENSOR MOUNTING BRACKET (not shown)	1

Pos	Part No	Description	Qty
1	<i>BP-400DSTUB-1</i>	<i>ROUND STUB (DROP AXLE MACHINED)</i>	
2	<i>BP-400DSTUB-2</i>	<i>HUB</i>	
3	BP-400DSTUB-3	BEARING KIT 2788 /2720 + LM67048 /LM67010	
4	BP-400DSTUB-4	DUST SEAL 3" x 1 7/8" x 3/8"	
5	<i>BP-400DSTUB-5</i>	<i>KEYED WASHER 1 1/4"</i>	
6	BP-400DSTUB-6	DUST CAP 59mm	
7	BP-400DSTUB-7	WHEEL STUD 1/2"	
8	BP-400DSTUB-8	WHEEL NUT 1/2"	
9	<i>BP-400DSTUB-9</i>	<i>SLOTTED NUT 1 1/4" UNF</i>	
10	<i>BP-400DSTUB-10</i>	<i>SPLIT PIN 50 x 5mm</i>	

### NOTE

*Drawing are for illustration purposes only.  
Please refer to the parts list.*

### NOTE

*Parts in Italics are non-stocked items and may need to be ordered.*



## PART NO: BP-400JA 3000L SUSPENSION TANDEM AXLE

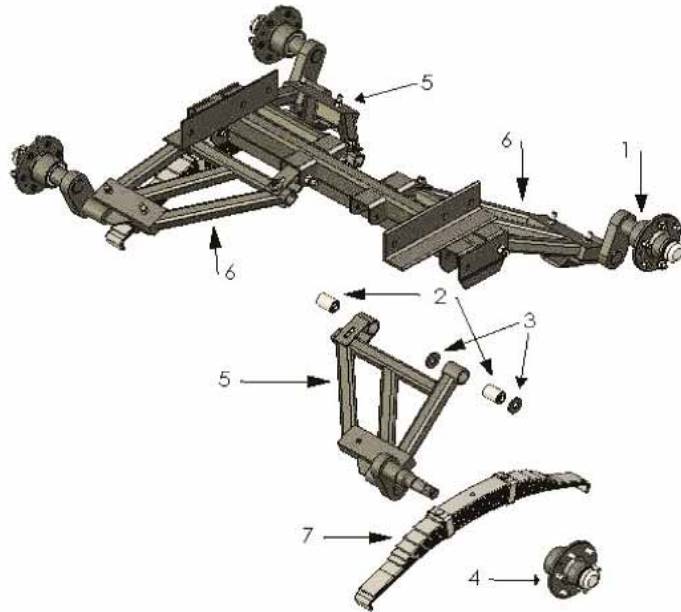

## PART NO: HP-199DA STUB AXLE

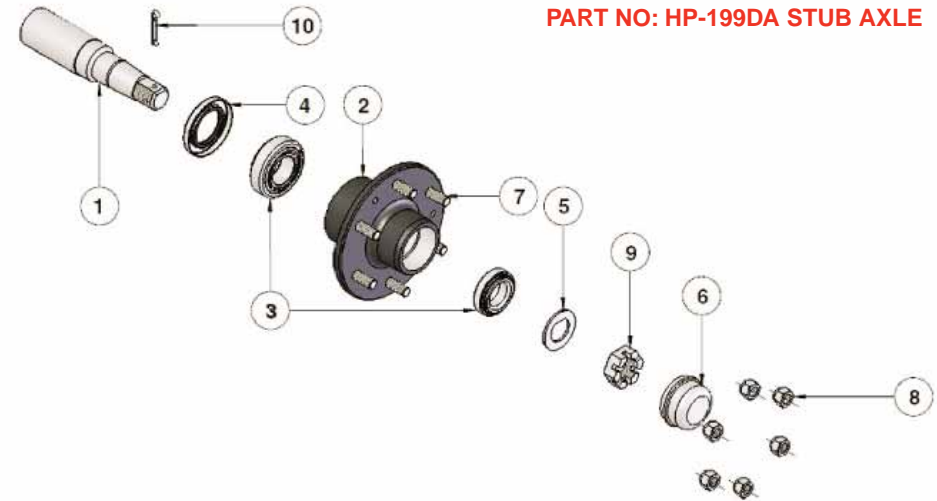

Pos	Part No	Description	Qty
1	HP-199DA	STUB AXLE 65MM ROUND 6/205PCD	4
2	BP-400-2	PIVOT BUSH TRAILING ARM 5/8"	8
3	BP-400-3	THRUST WASHER	4
4	<i>BP-400JA-4</i>	<i>HUB COMPLETE (Bearings, Seal and Dust Cap)</i>	
5	BP-400J-1	TRAILING ARM LEFT FRONT / RIGHT BACK	2
6	<i>BP-400J-2</i>	<i>TRAILING ARM RIGHT FRONT / LEFT BACK</i>	2
7	BP-400JLSPRING	SPRING ASSY BP-400JL	
8	MT10013	SPEED SENSOR MOUNTING BRACKET (not shown)	1

Pos	Part No	Description	Qty
1	<i>HP-199DA-1</i>	<i>STUB AXLE 65RD x 438LG</i>	
2	<i>HP-199DA-2</i>	<i>HUB 6/205PCD</i>	
3	HP-199DA-3	BEARING KIT 30208/30211	
4	<i>HP-199DA-4</i>	<i>TRIPLE LIP SEAL 100 x 70 x 12mm</i>	
4a	<i>HP-199DA-4A</i>	<i>SEAL RING 57 x 70.5 x 16.5mm (not shown)</i>	
4b	<i>HP-199DA-4B</i>	<i>WEAR RING TO SUIT T.L.S (not shown)</i>	
5	N/A	N/A	
6	<i>HP-199DA-6</i>	<i>DUST CAP (3 screws items 11 and 12)</i>	
7	HP-199DA-7	WHEEL STUD M18 x 1.5 x 65	
8	HP-199DA-8	WHEEL NUT M18 x 1.5	
9	<i>HP-199DA-9</i>	<i>SLOTTED NUT M33 x 2</i>	
10	<i>HP-199DA-10</i>	<i>SPLIT PIN M50x6</i>	
11	<i>HP-199DA-11</i>	<i>SOCKET HEAD CAP SCREW M8 x 25 (not shown)</i>	
12	<i>HP-199DA-12</i>	<i>RIB LOCK WASHER M8 (not shown)</i>	

### NOTE

Drawing are for illustration purposes only.  
Please refer to the parts list.

### NOTE

Parts in *Italics* are non-stocked items and may need to be ordered.

## PART NO: BP-400ADA 4000L SUSPENSION TANDEM AXLE

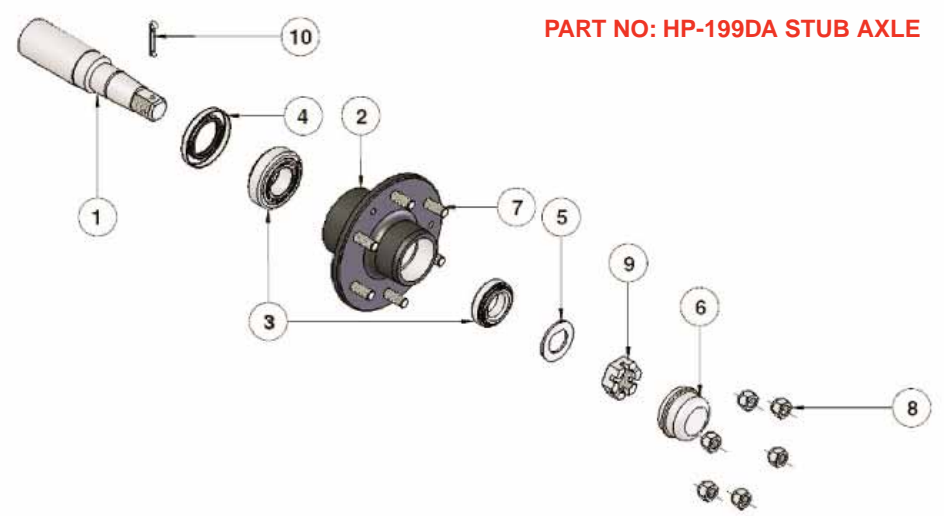
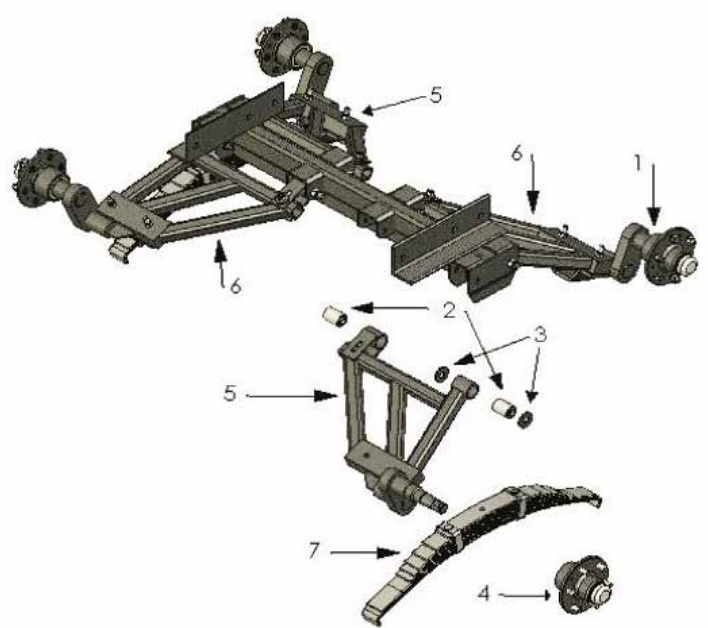

## PART NO: HP-199DA STUB AXLE

Pos	Part No	Description	Qty
1	HP-199DA	STUB AXLE 65MM ROUND 6/205PCD	4
2	BP-400-2	PIVOT BUSH TRAILING ARM 5/8"	8
3	BP-400-3	THRUST WASHER	4
4	BP-400ADA-4	HUB COMPLETE (Bearings, Seal and Dust Cap)	
5	BP-400AD-1	TRAILING ARM LEFT FRONT / RIGHT BACK	2
6	BP-400AD-2	TRAILING ARM RIGHT FRONT / LEFT BACK	2
7	BP-400ADLSPRING	SPRING ASSY BP-400ADL	2
8	MT10013	SPEED SENSOR MOUNTING BRACKET (not shown)	1

Pos	Part No	Description	Qty
1	<i>HP-199DA-1</i>	<i>STUB AXLE 65RD x 438LG</i>	
2	<i>HP-199DA-2</i>	<i>HUB 6/205PCD</i>	
3	<i>HP-199DA-3</i>	<i>BEARING KIT 30208/30211</i>	
4	<i>HP-199DA-4</i>	<i>TRIPLE LIP SEAL 100 x 70 x 12mm</i>	
4a	<i>HP-199DA-4A</i>	<i>SEAL RING 57 x 70.5 x 16.5mm (not shown)</i>	
4b	<i>HP-199DA-4B</i>	<i>WEAR RING TO SUIT T.L.S (not shown)</i>	
5	<i>N/A</i>	<i>N/A</i>	
6	<i>HP-199DA-6</i>	<i>DUST CAP (3 screws items 11 and 12)</i>	
7	<i>HP-199DA-7</i>	<i>WHEEL STUD M18 x 1.5 x 65</i>	
8	<i>HP-199DA-8</i>	<i>WHEEL NUT M18 x 1.5</i>	
9	<i>HP-199DA-9</i>	<i>SLOTTED NUT M33 x 2</i>	
10	<i>HP-199DA-10</i>	<i>SPLIT PIN M50x6</i>	
11	<i>HP-199DA-11</i>	<i>SOCKET HEAD CAP SCREW M8 x 25 (not shown)</i>	
12	<i>HP-199DA-12</i>	<i>RIB LOCK WASHER M8 (not shown)</i>	

**NOTE**  
 Drawing are for illustration purposes only.  
 Please refer to the parts list.

**NOTE**  
 Parts in Italics are non-stocked items and may need to be ordered.

## SARDI Fans



PART No.	DESCRIPTION	DATE
HP-011DA	FAN – SARDI 500mm (It)	2007 - 2009
HP-011D	FAN – SARDI 500mm (Ch)	2009 - 2012
HP-011DB	FANJ – SARDI 500mm (Ch)	2012+



PART No.	DESCRIPTION	DATE
HP-119-10	FAN – SARDI 380mm (Aust)	2007 - 2010
HP-119-10A	FAN – SARDI 380mm (Ch)	2010 -

## NOTE

*This drawing is for illustration purposes only.  
Please refer to the parts list.*

## Quantum Mist, QM-500 Spray Head Assembly (2007 - Current)

### Drive Body, HP-219-9D

The fully assembled drive body is now a stand alone, "non serviceable part".



Includes HP-219-25 Coupler (ex FISEM10)



#### NOTE

*The Drive Body, HP-219-9D will fit spray heads back to 2004. Prior to 2004 is now classified as obsolete.*

#### NOTE

*The motor shown in this picture is the 6.5cc version (HP-219M6.5CE) (which is used in some QM-500 applications (citrus)).*

*The only visible difference is the length of the main body - the red section of the 6.5cc motor is 60mm long.*

### Hydraulic Motor:

- **HP-219M9.8CE**

The bare hydraulic (rear port) motor



HP-219M9.8CE

OR

- **HP-219M9.8CE-1,**

The HP-219M9.8CE motor combined with:

- Locating ring - HP-219-4A, and
- Splined coupler - HP-219-24 (male) (ex FISEM 09)

HP-219-4A  
Locating Ring



HP-219-24 (male) Coupling  
(ex FISEM 09)



HP-219M9.8CE-1



Use motor housing bolts:  
M6 x 25 SS bolts + washers

#### NOTE

*In some cases the motor supplied will be painted in a protective black epoxy coating.*



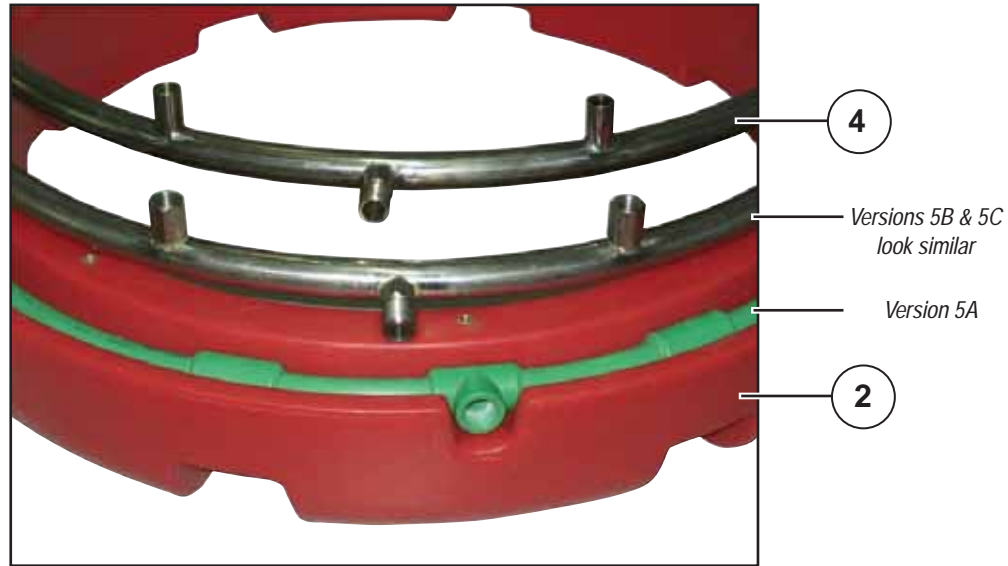

Pos	Part No	Description
1	HP-219-3B	Fan Cowling - Front & Rear (Sold as a matched pair, red colour)
2	HP-219-6B	Front Guard (Powder coated, stainless steel, black colour)
3	HP-219-7B	Rear Guard (Powder coated, stainless steel, black colour)
4	HP-219-5D	Spray Ring (stainless steel) - See notes the different versions
5	HP-219-15B	Centre Cover Plate (Incorporates the Croplands/SARDI Label)
6	HP-219-20	Retaining Flange (Note there are 2 versions (cast or machined))

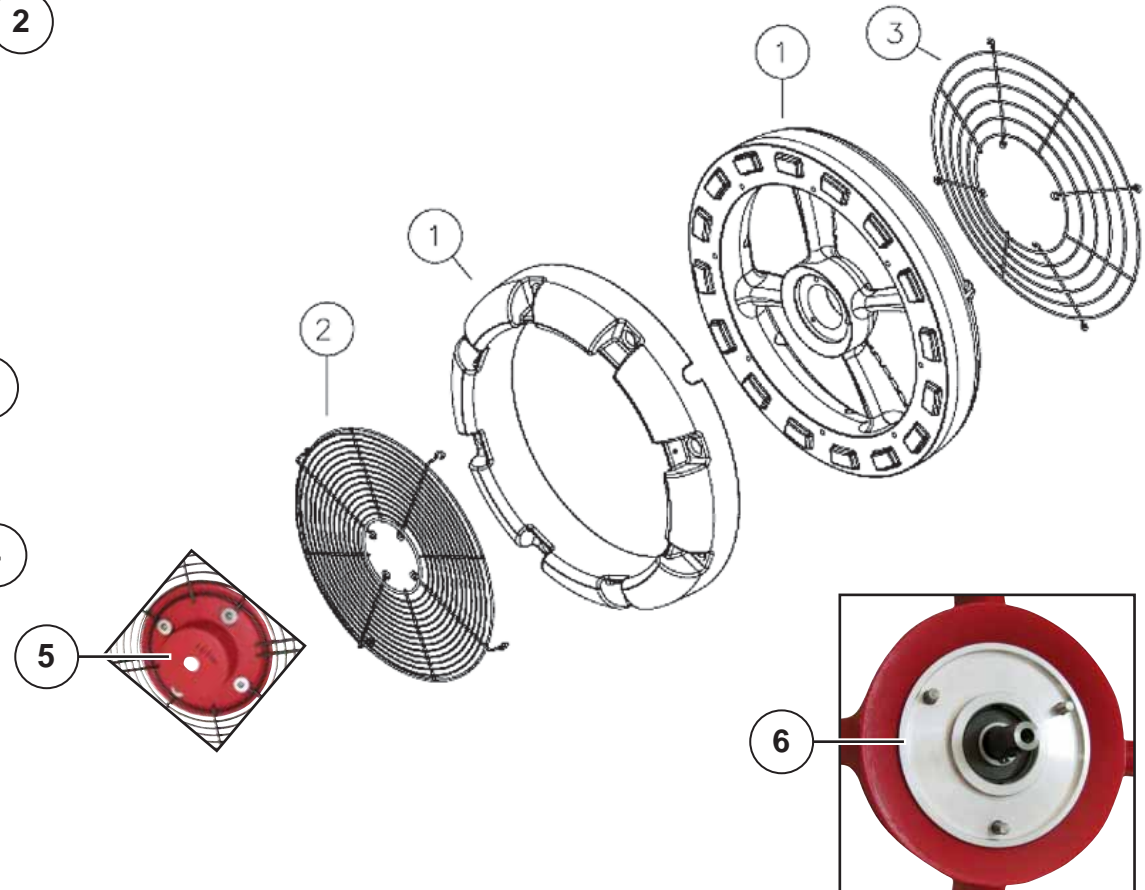
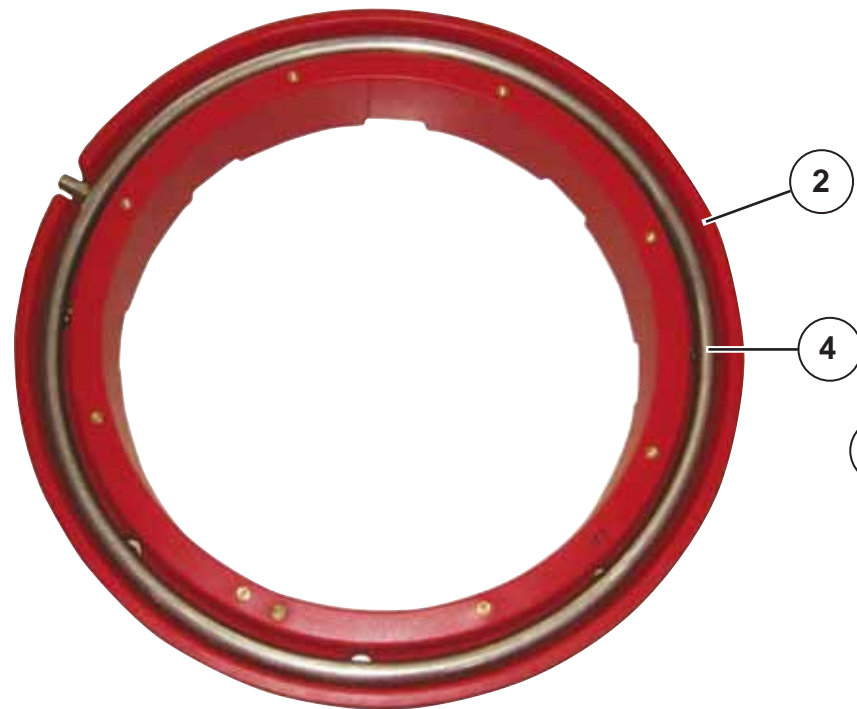



Shaft bolt M8 x 25 SS,  
spring washer & large  
flat washer

Fan bolts M8 x 30 SS,  
spring washers & flat  
washers

Mounting Hub  
HP-219-16C

Fan HP-011D



Mounting bolts M12 x 40 SS  
& spring washers

Mounting Bracket  
HP-219-8B

Drive Body  
HP-219-9D



**Swivels**



Single, HP-219-22A / B264.612.172



Shut off nozzle, B67.617.67



Double nozzle, HP-219-23 / B264.612.171

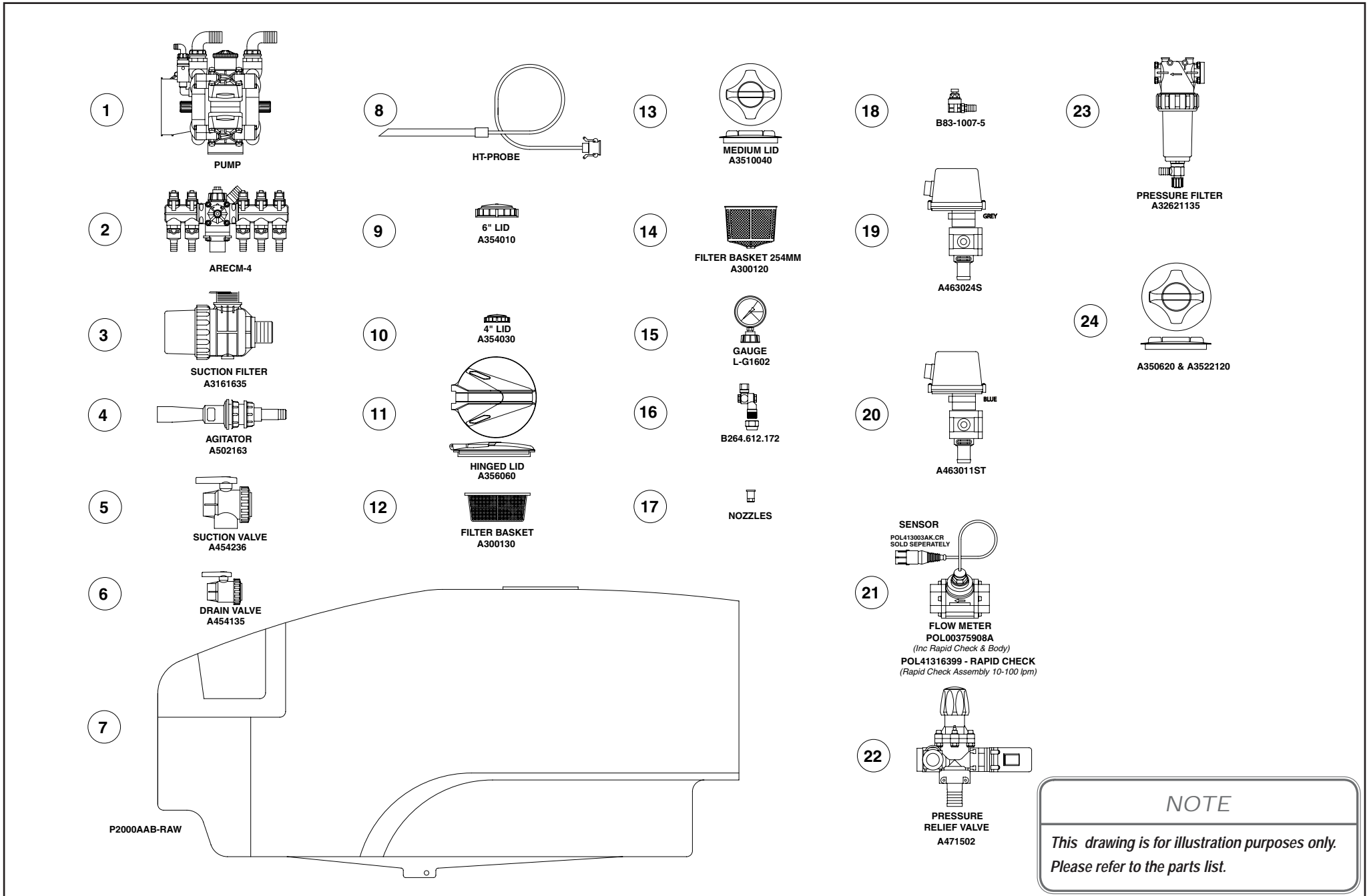

**NOTE**

*This drawing is for illustration purposes only.  
Please refer to the parts list.*



Pos	Part No	Description	Qty
1	AR PUMP	AR PUMP	1
2	ARECM-4	ECM 4 WAY LESS FILTER #30027	1
3	A3161635	FILTER 1 1/2" 50 MESH	1
4	A502163	AGITATOR	2
5	A344236	BALL VALVE POLY 1 1/2" 3 WAY	1
6	A454135	BALL VALVE POLY 1 1/4" 2 WAY	1
7	P2000AB-RAW	TANK 2000LT POLY RAW AIRBLAST	1
7a	P2000AAB-130RAW	2000 HORT 130L FLUSH TANK	1
7b	P2000AAB-15RAW	2000 HORT 15L HANDWASH TANK	1
8	HT-PROBE	CHEMICAL SUCTION PROBE (option)	1
9	A354010	LID 6" c/w BREATHER & SEAL	1
10	A354030	LID 4" c/w BREATHER & SEAL	1
11	A356060	LID, HINGED 180degrees 382mm	1
12	A300130	FILTER BASKET 254mm DEEP	1
13	A3510040	LID, MEDIUM 355mm	1
14	A300120	FILTER BASKET 254mm DEEP	1
15	L-G1612	GAUGE 100MM 2500KPA	1
16	B264.612.172	SWIVEL NOZZLE SINGLE 1/4"BSPM	8/fan
17	AZ-ATR-YW-80C	JET CONE ATR 80 DEG (YELLOW)	4/fan
	AZ-ATR-BN-80C	JET CONE ATR 80 DEG (BROWN)	4/fan
18	B83-1007-5	DIAPHRAM TAP 1/4"BSP	1/fan
19	A463024S	PROPORTIONAL SERVO VALVE 7 SEC	2
20	A463011ST	DUMP/BOOM SHUT OFF VALVE 3 WIRE	1

Pos	Part No	Description	Qty
21	POL00375908A	FLOW METER R/CHECK ZAFF	1
22	A471502	RELIEF & DUMP VALVE ASSEMBLY	1
23	A32621135	FILTER S/F 80MESH FLANGED TYPE	1
24	HP-298-8	OIL COOLER 25EK1/1	1
25	<i>HP-223B</i>	<i>MANIFOLD SOFT START FLOW</i>	1
26	HP-223B-1	ACCUMULATOR 0.75/250/M14X1.5	1

**NOTE**

*Parts in Italics are non-stocked items and may need to be ordered.*

Arag wiring diagram key			
Pin pos.	Colour	Function	(+/-)
1			
2			
3	Pink	Boom 1	(-)
4	Black	Pressure	(-)
5	Red	Pressure	(+)
6	Y/Green	Boom 1	(+)
7	Brown	Dump	(-)
8	Purple	Boom 2	(-)
9	Light Blue	Boom 2	(+)
10	Blue	Dump	(+)
11	Grey	Boom3	(-)
12	White	Boom 3	(+)

ARAG CONTROL PANEL

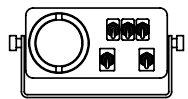

A4662632

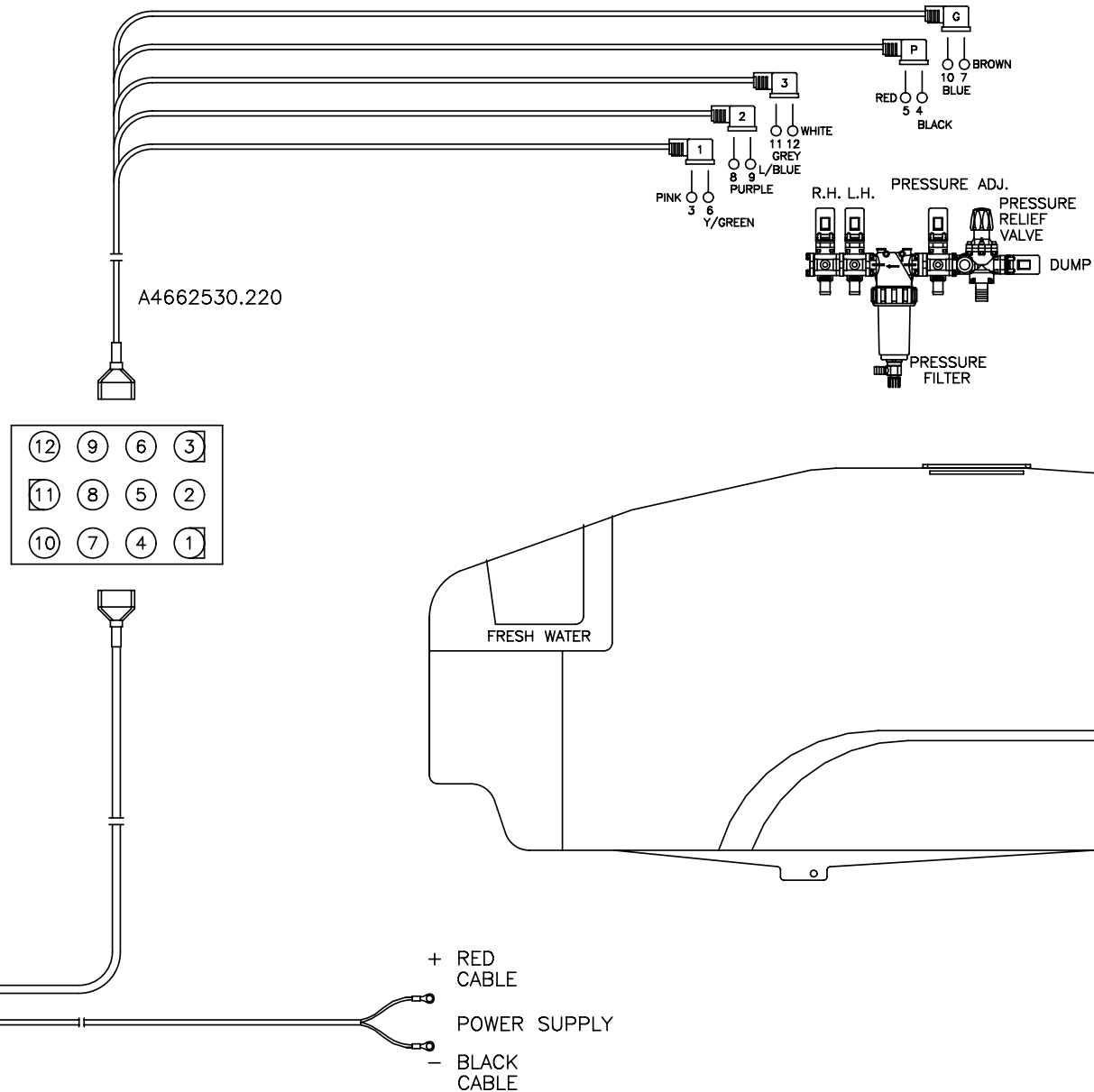



# Electrical Diagram - Terracing Hydraulics Assembly Drawings & Parts

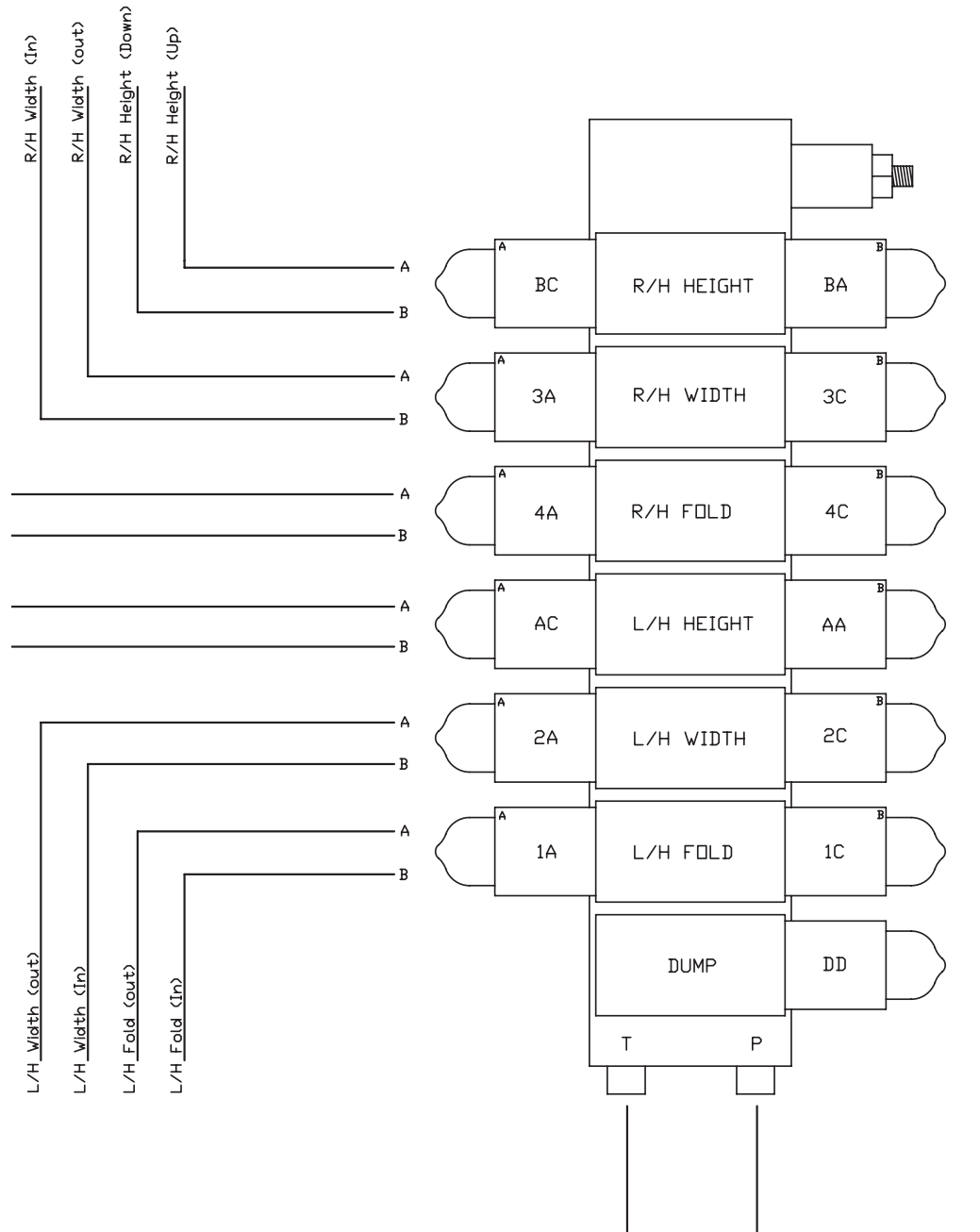
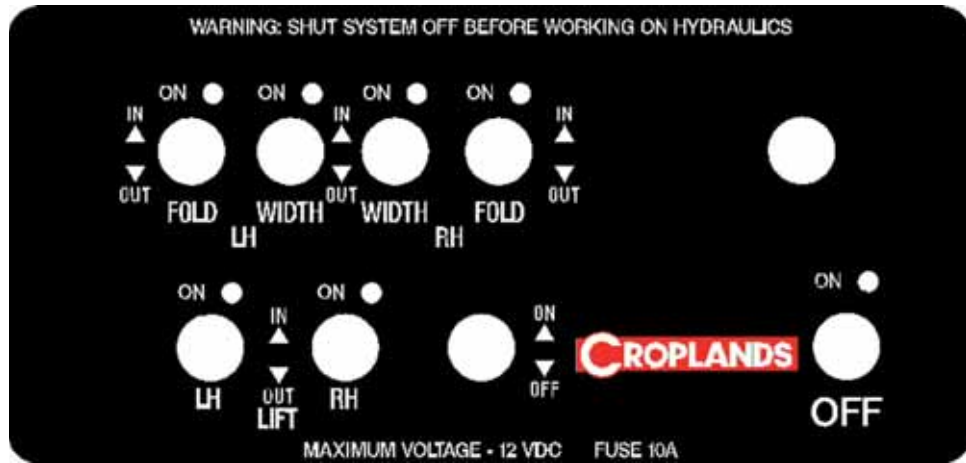



## Suction/Pressure Line Plumbing HT-ARAG

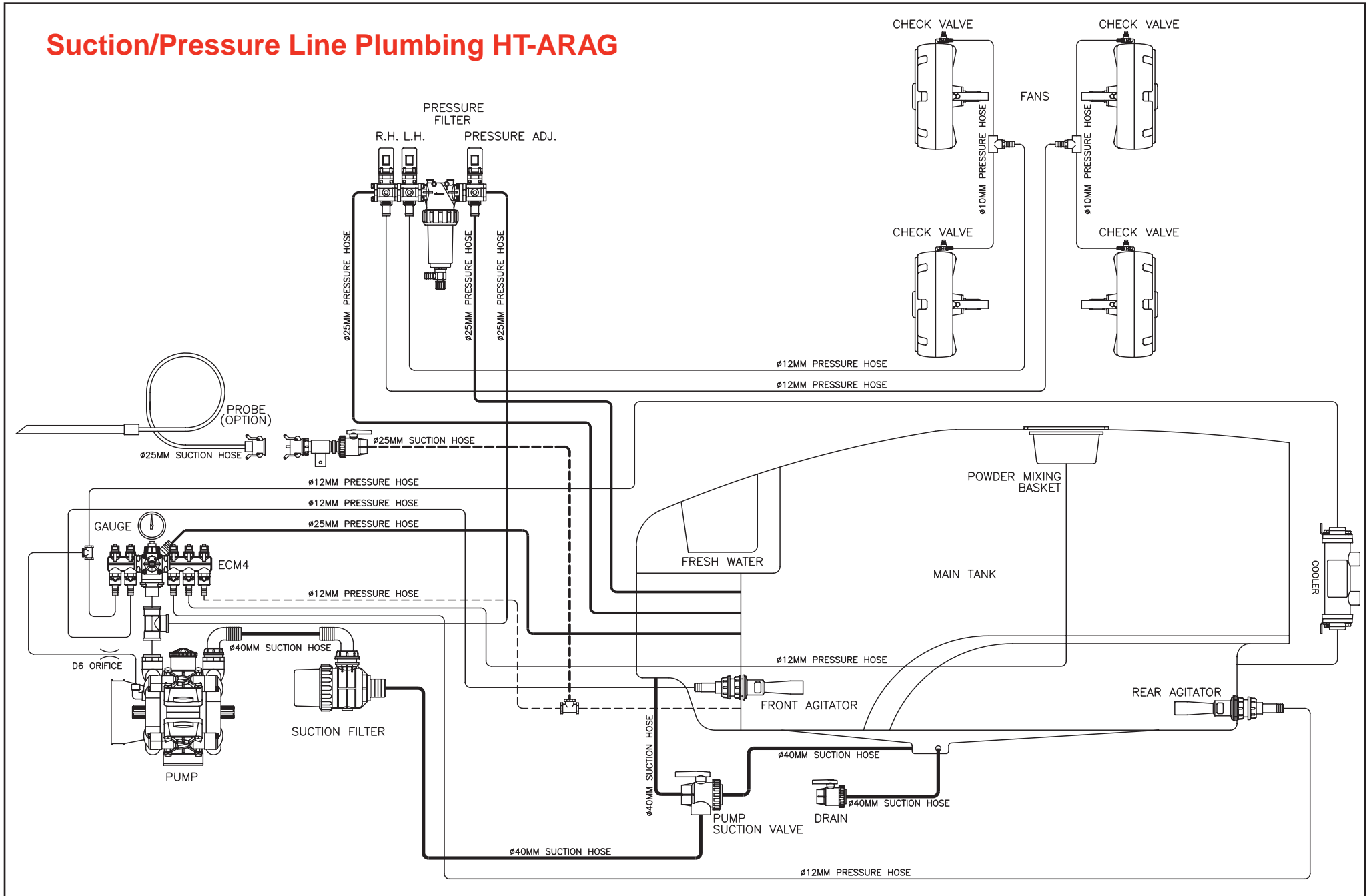

## Suction/Pressure Line Plumbing MT3405F/HV4000

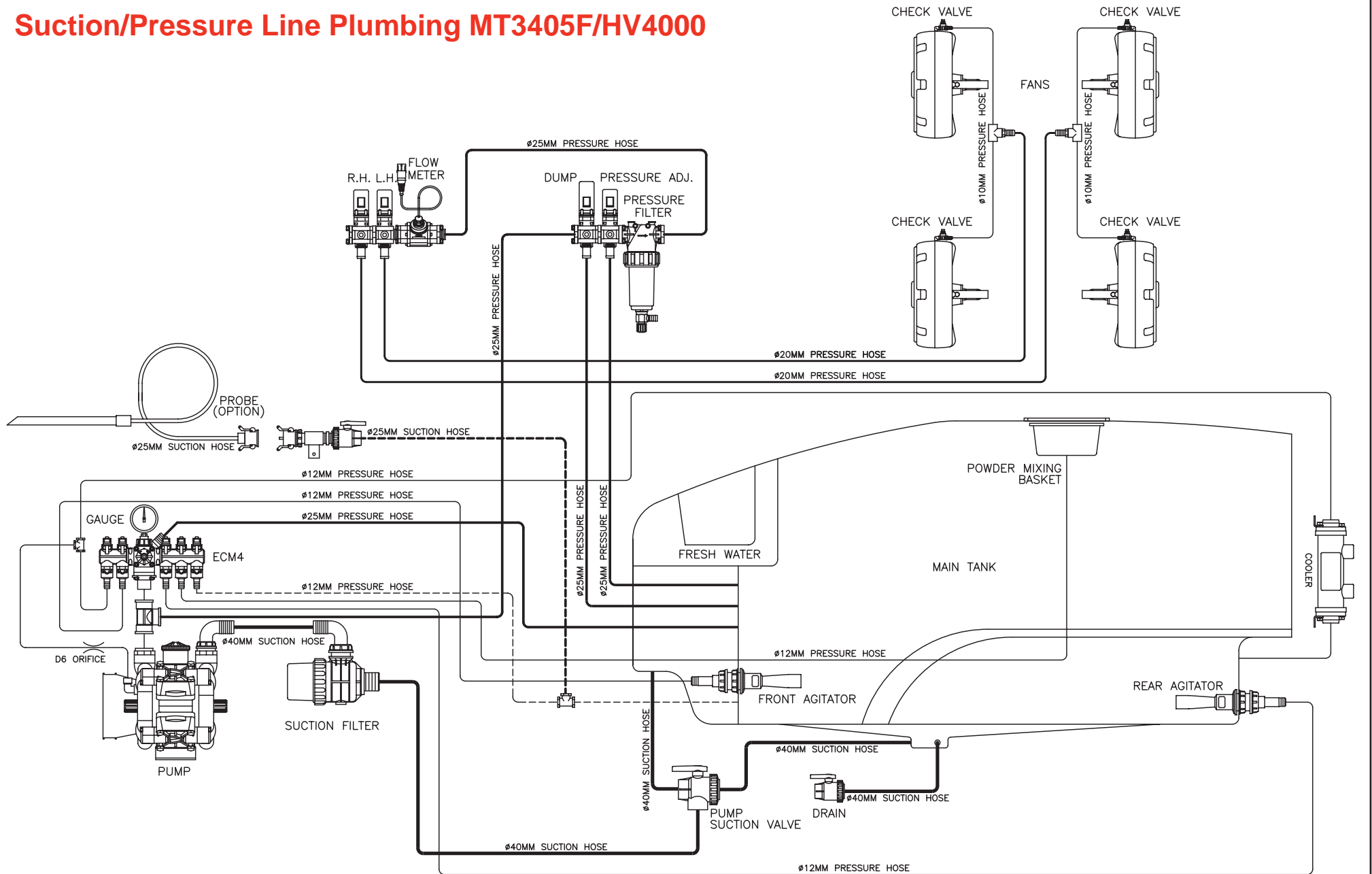

## Suction/Pressure Line Plumbing Manual Control

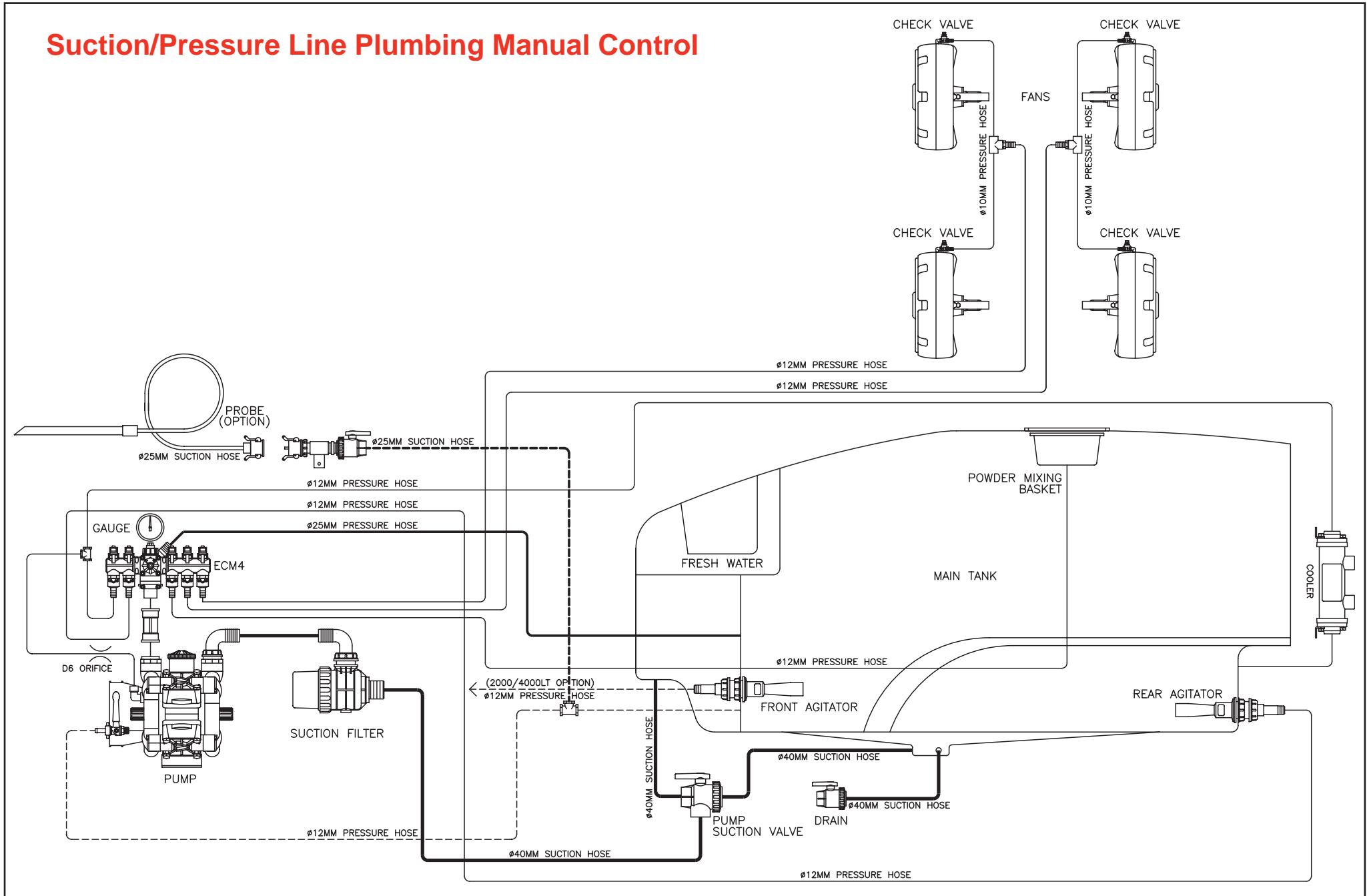

## Suction/Pressure Line Plumbing HT-ARAG

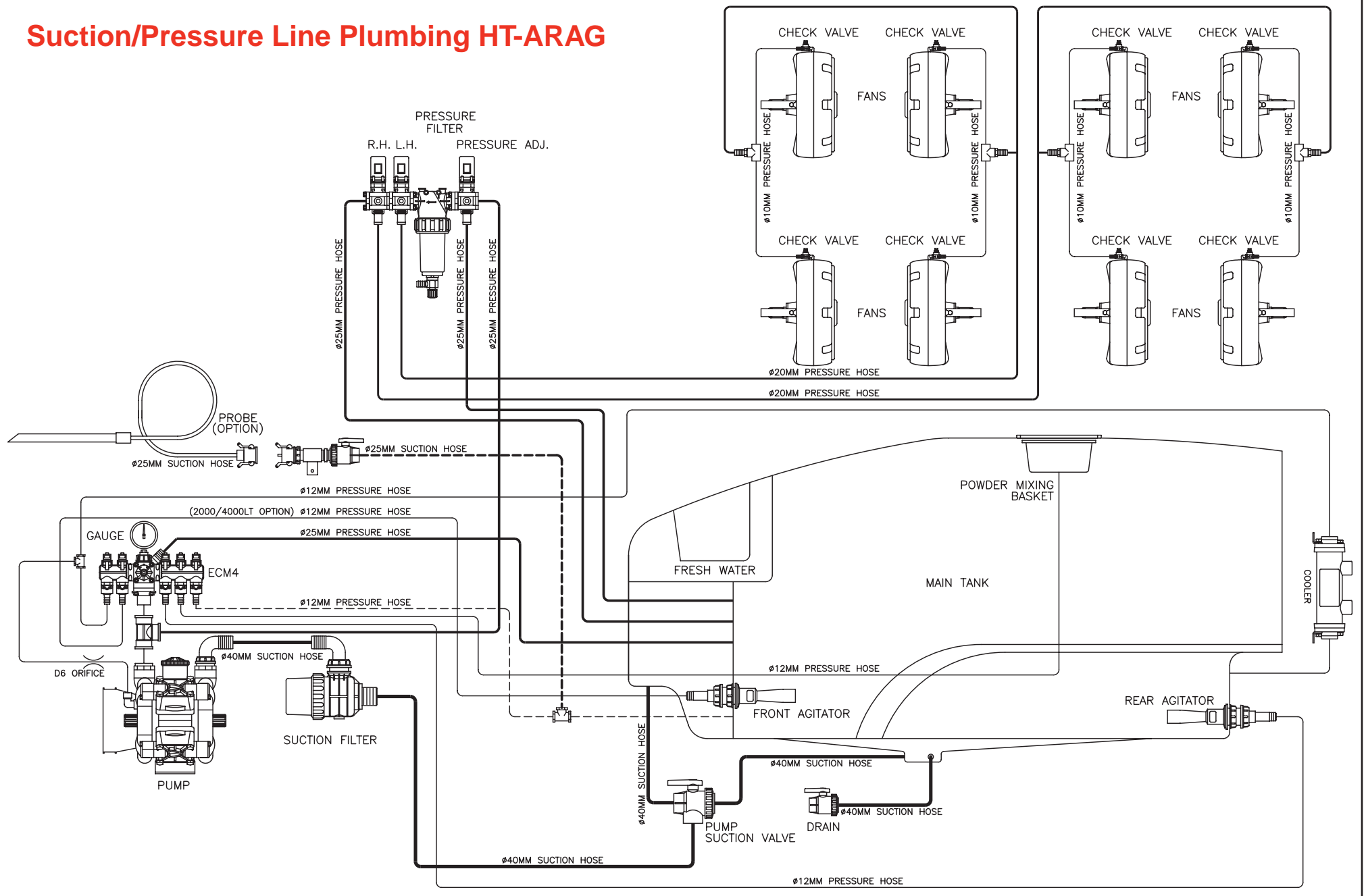

## Suction/Pressure Line Plumbing MT3405F/HV4000

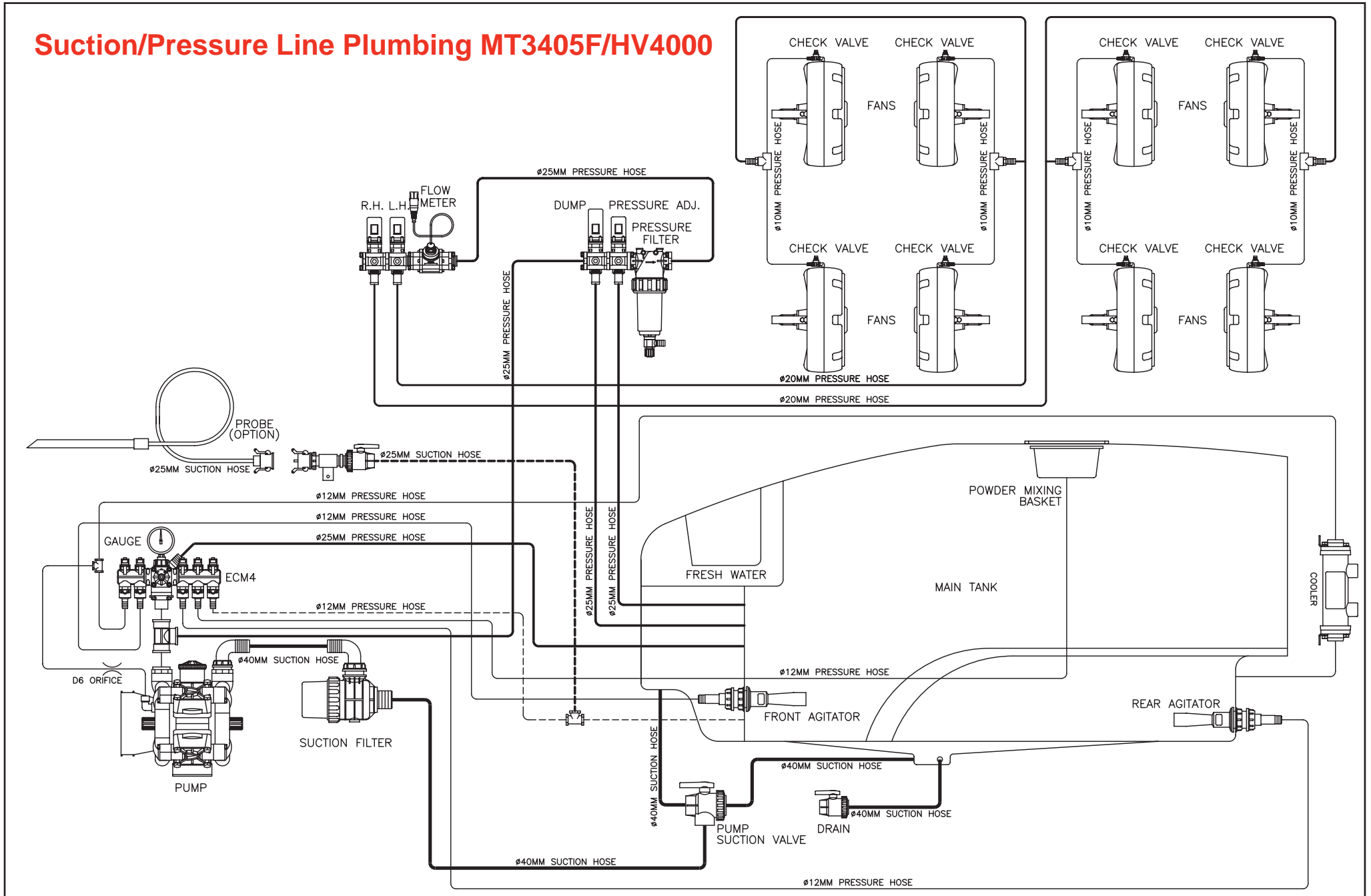



## Hydraulic Wing Fold - Over Row & Single Row

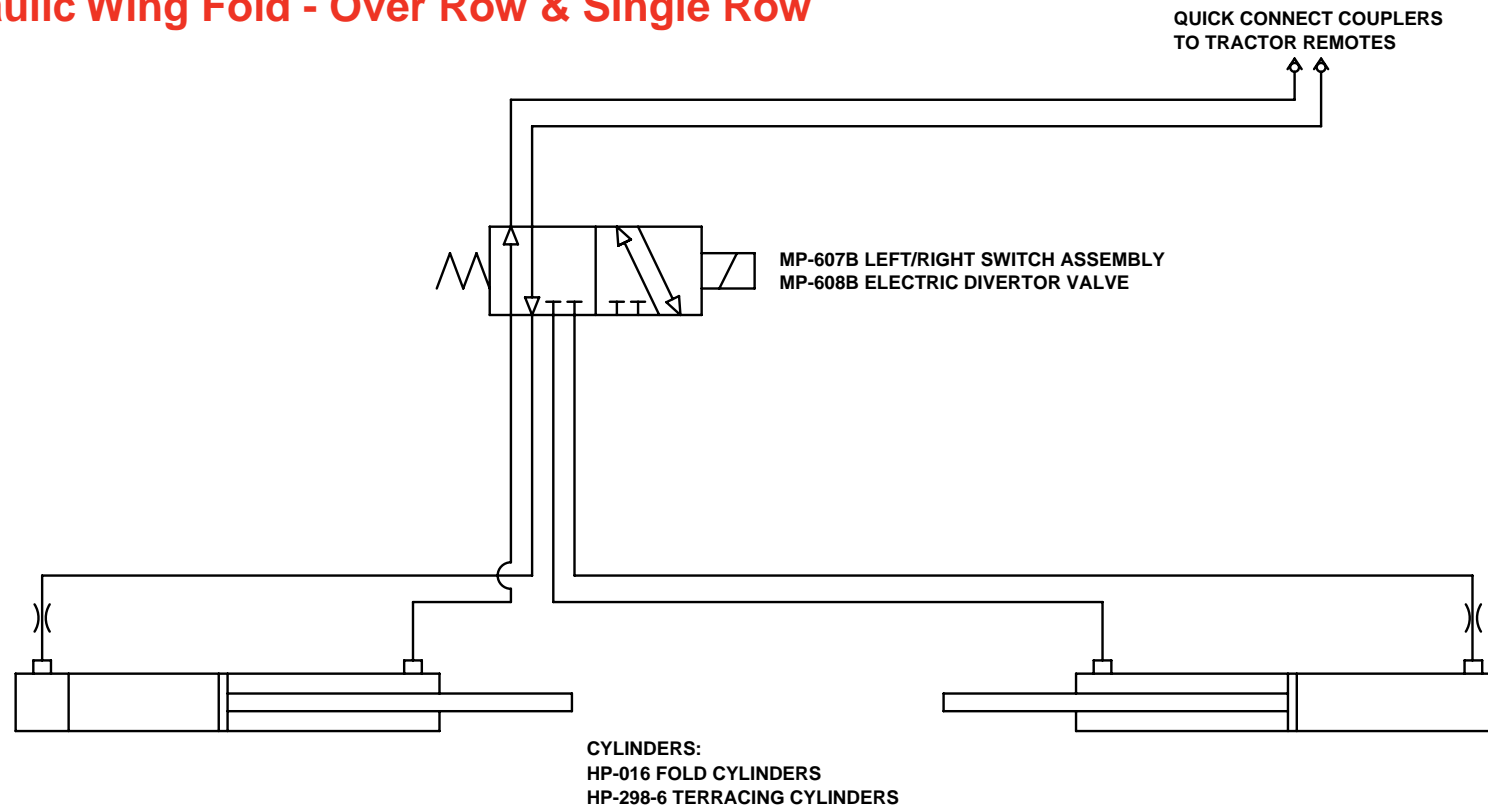

CYLINDERS:  
HP-016 FOLD CYLINDERS  
HP-298-6 TERRACING CYLINDERS

HYDRAULIC SCHEMATIC:  
OVER ROW FOLD OPTION  
AND SINGLE ROW TERRACE OPTION

HP-298-5A CONTROL

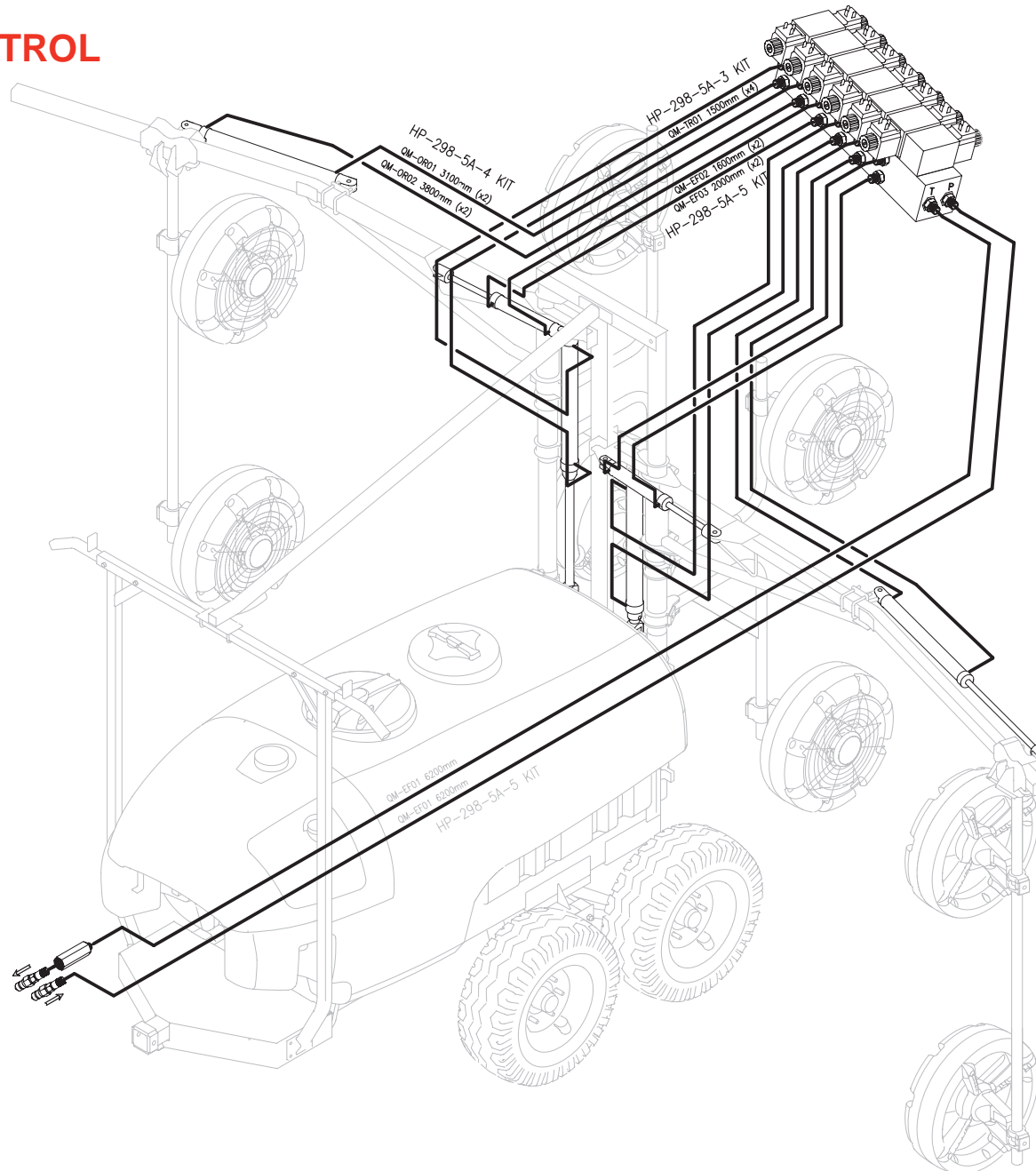

## HP-223C FAN CONTROL - Multiple Parallel Circuits

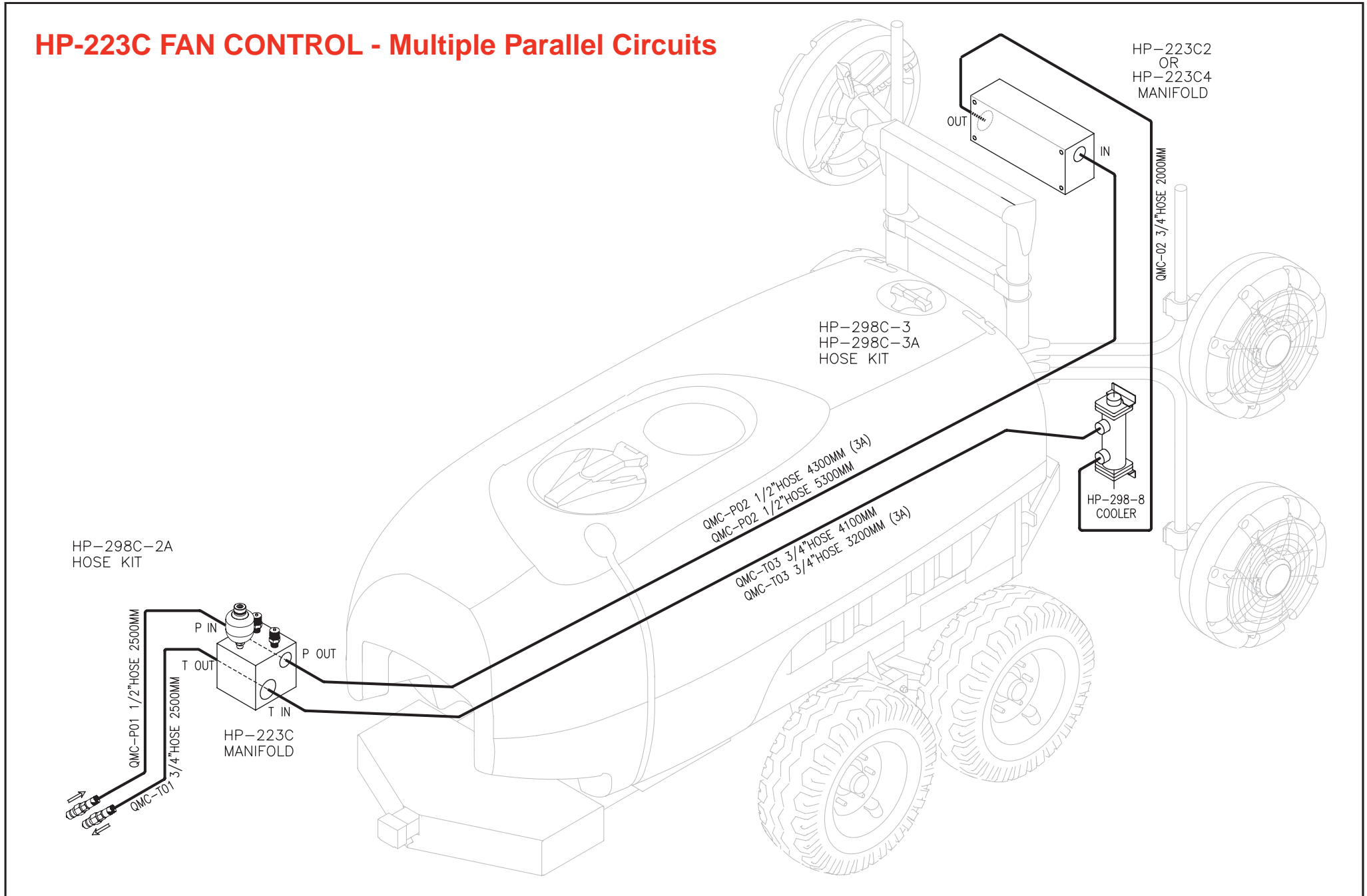

HP-223C FAN CONTROL - Single Fan Trailed Circuit

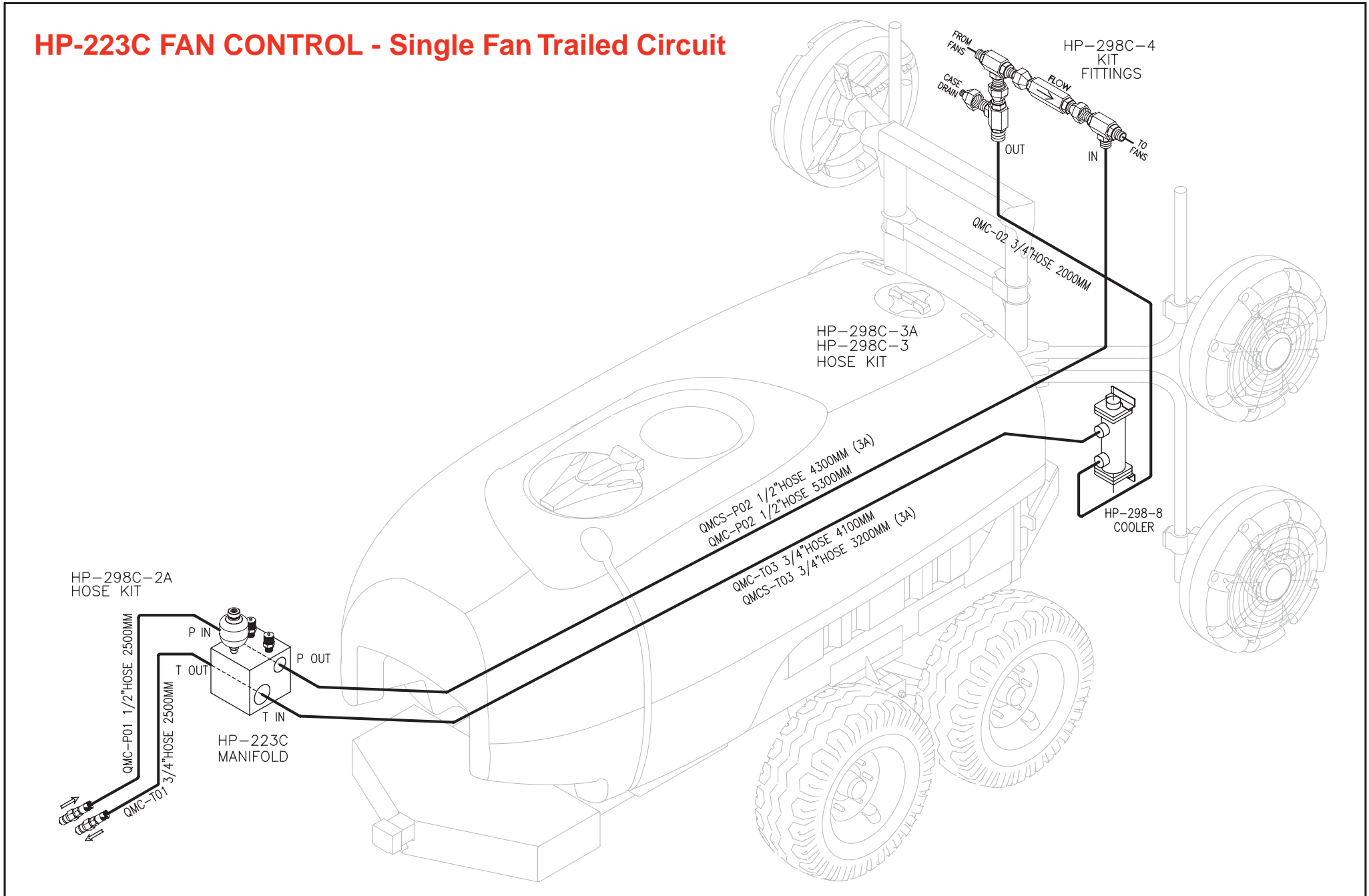

## HP-223C FAN CONTROL c/w HYDPACK2 - Multiple Parallel Circuits

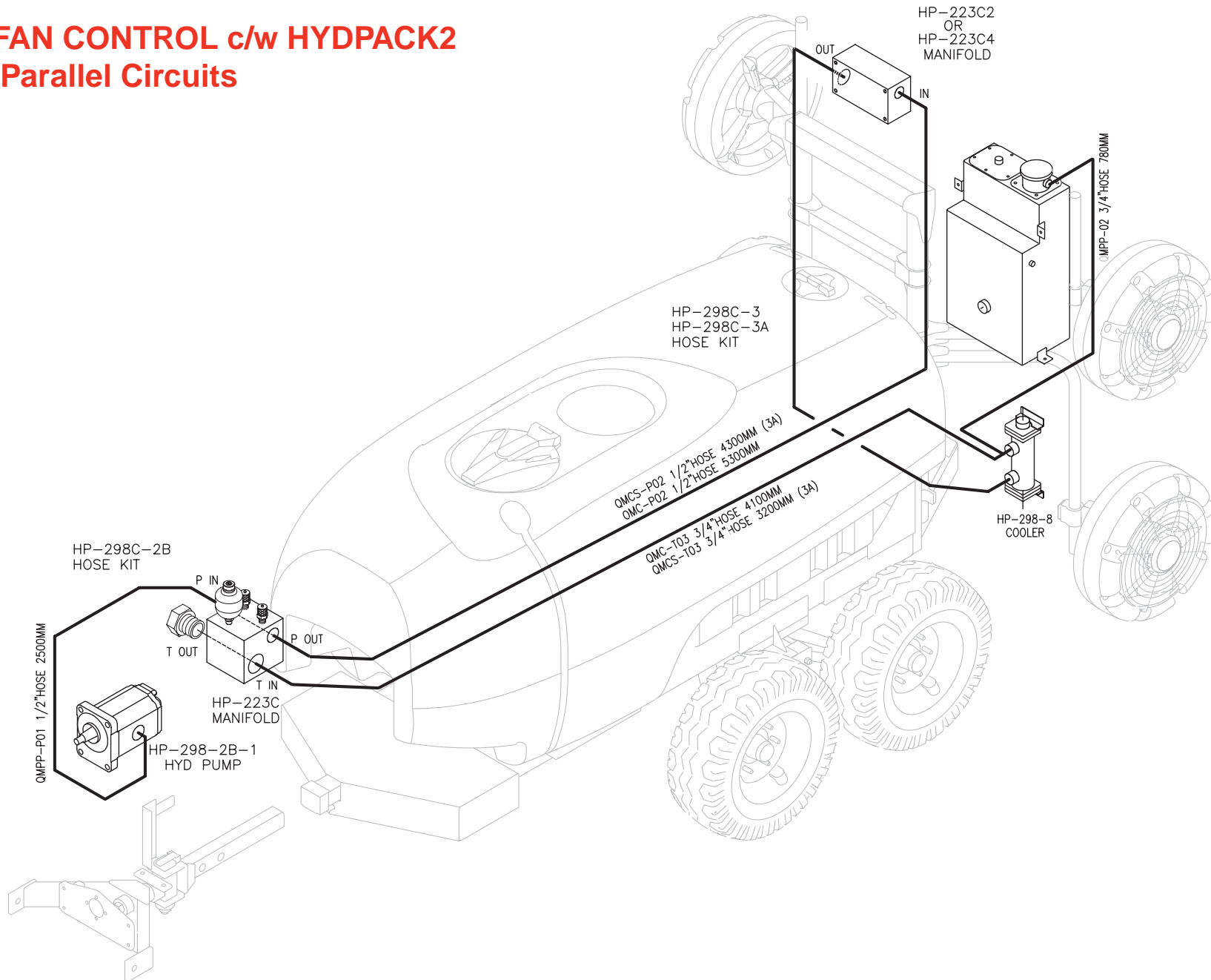



## HP-223C FAN CONTROL c/w HYDPACK3 - Multiple Parallel Circuits

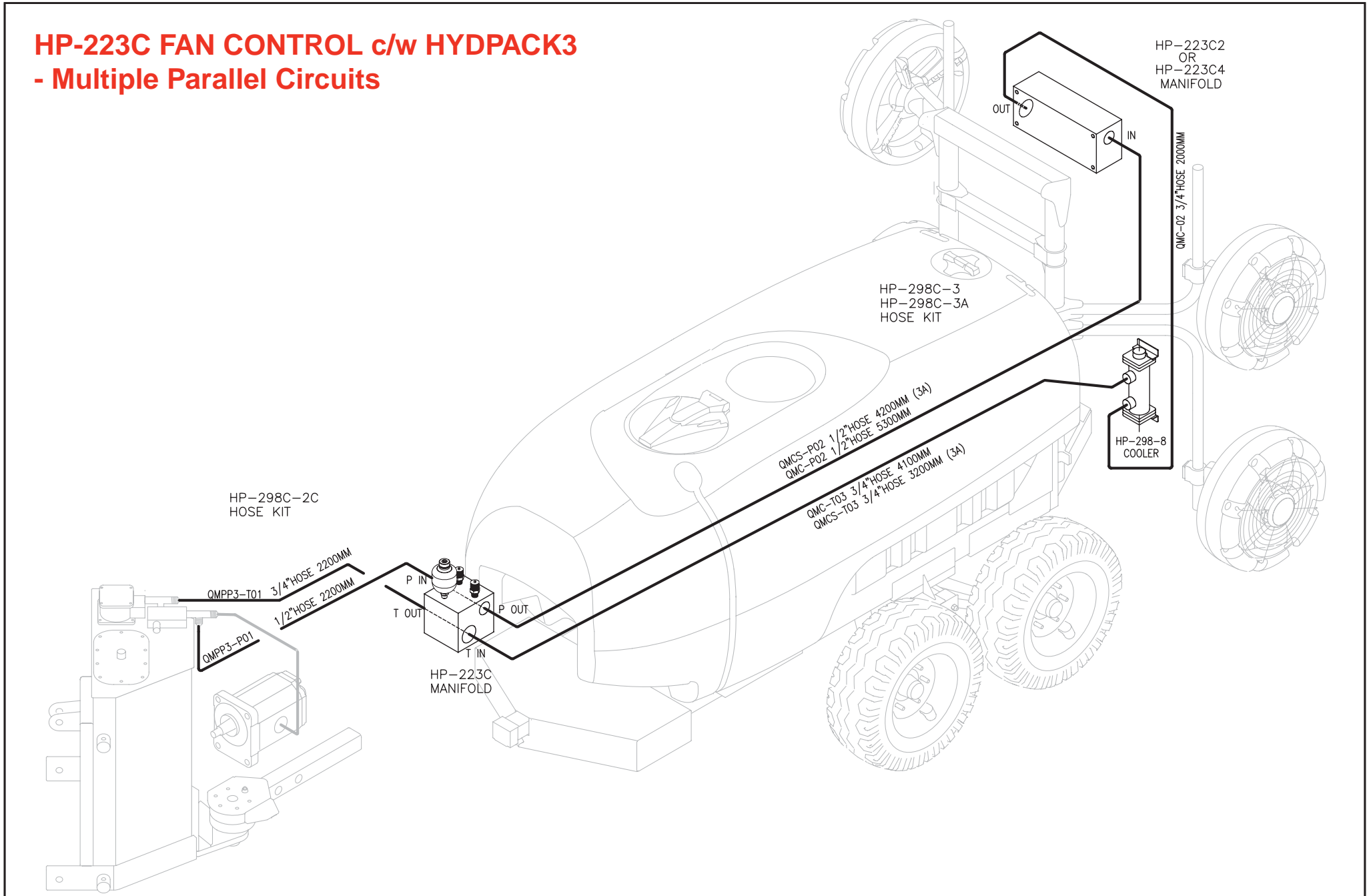

## HP-223C FAN CONTROL - Single Row Sprayer

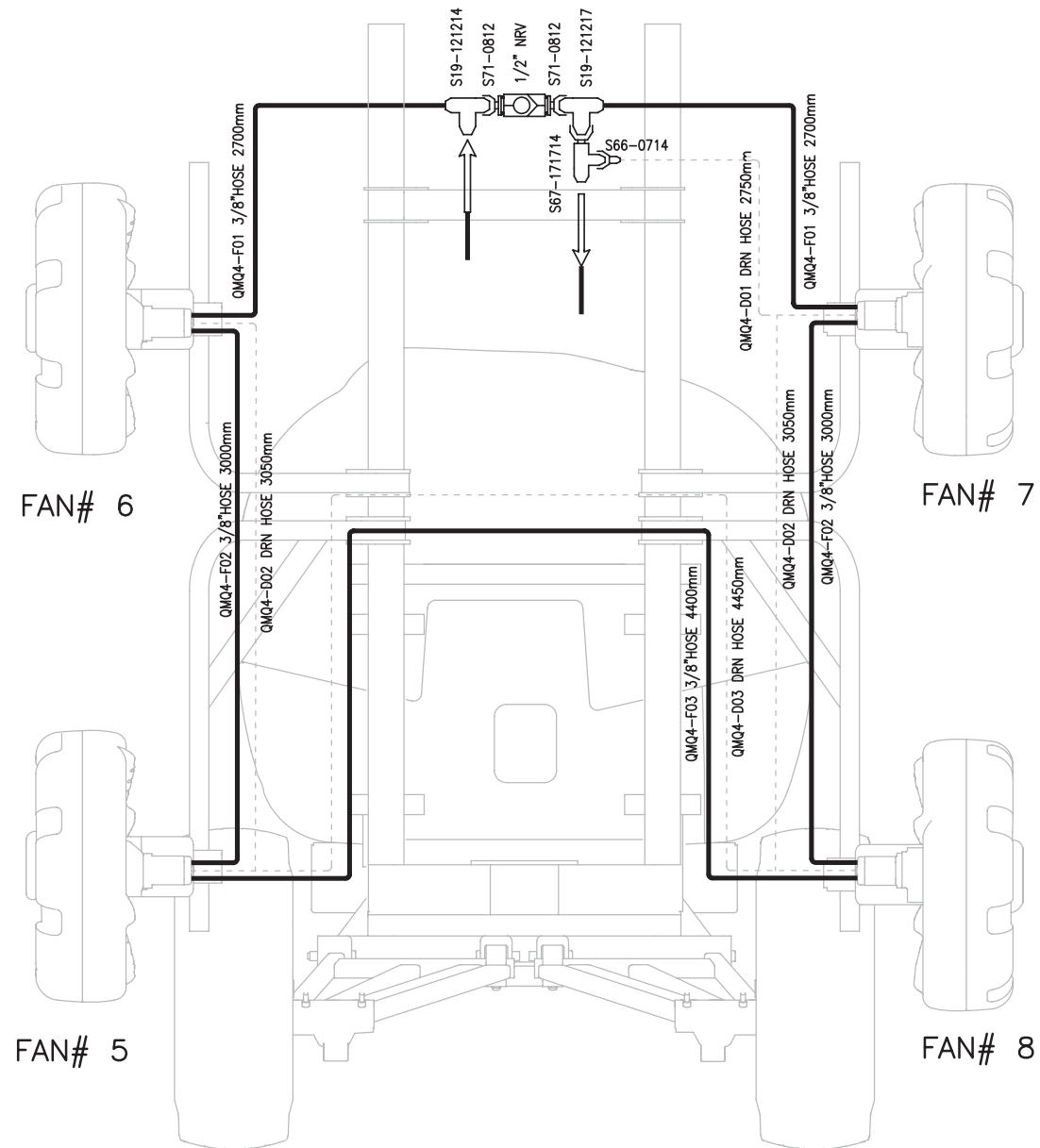

## HP-223C FAN CONTROL - Over Row Sprayer

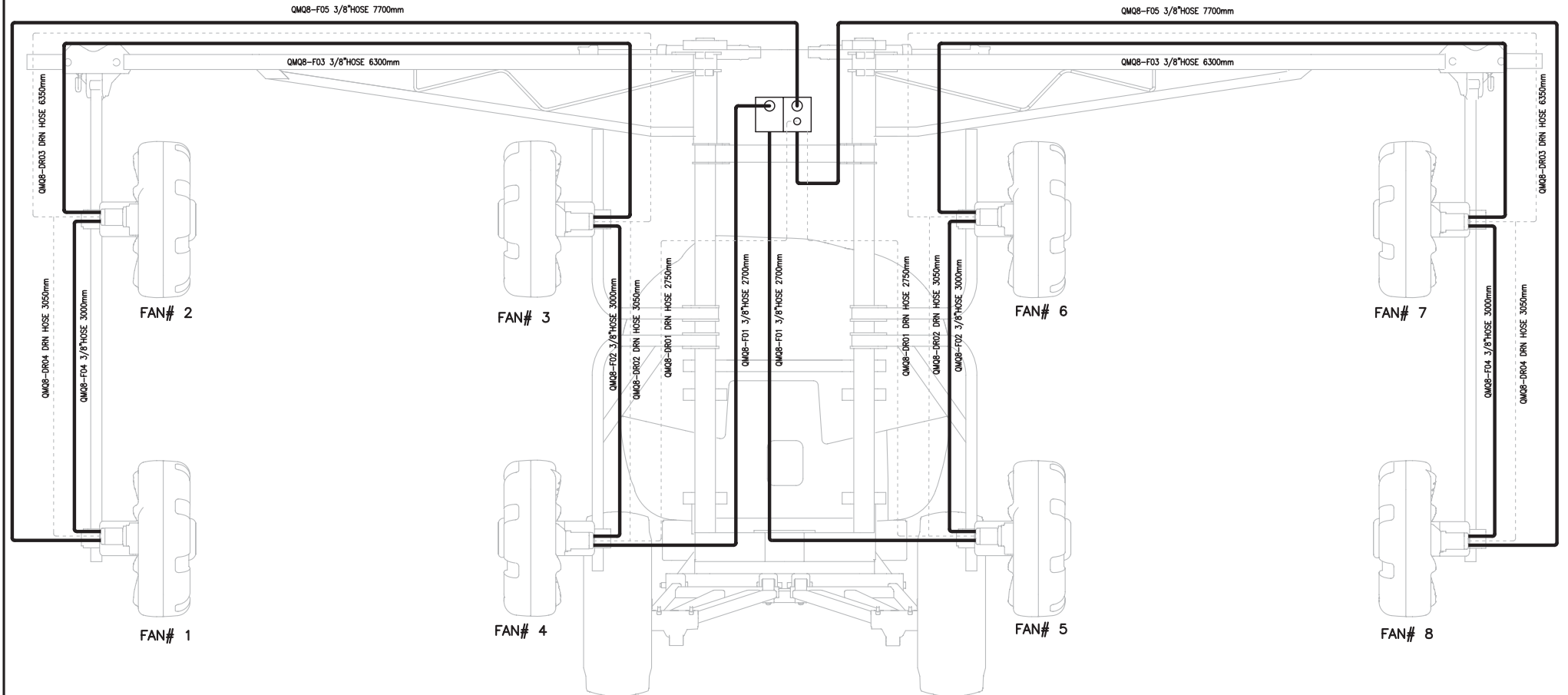

## HP-223C FAN CONTROL - Three Row Sprayer

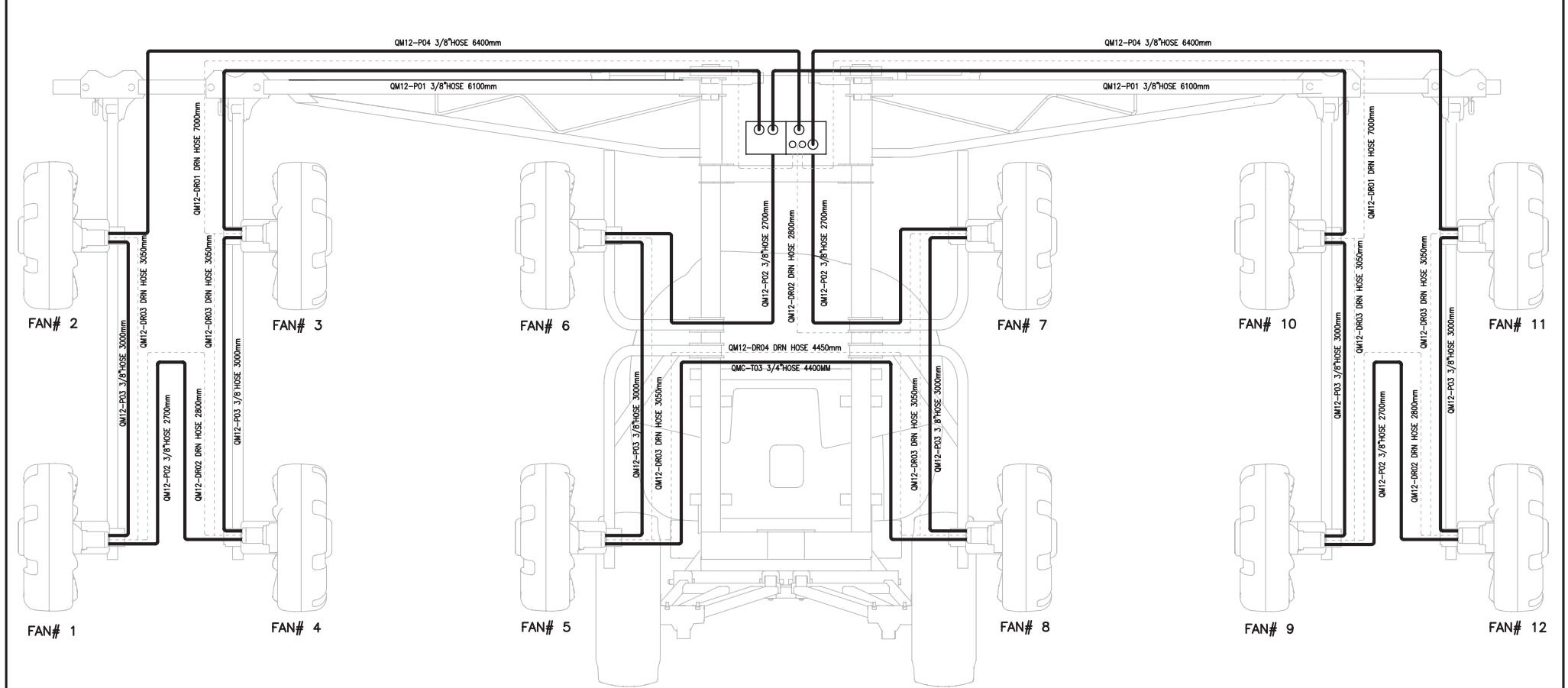

The following formulae may be useful when calibrating sprayers for orchard or tree applications.

## 1 Trees per Hectare

$$\frac{\text{Trees/Ha}}{10,000 \div \text{Row Spacing (m)} \div \text{Tree Spacing (m)}}$$

## 2 Total Litres per Minute

$$\frac{\text{Total Litres/Min}}{\text{Row Spacing (m)} \times \text{Litres/ha} \times \text{Speed (km/hr)} \div 600}$$

## 3 Tractor Speed

$$\frac{\text{km/hr}}{\text{metres travelled in one minute} \div 16.7}$$

OR

$$\frac{\text{mph}}{\text{feet travelled in one minute} \div 88}$$

## 4 Distance Travelled per Hectare

$$\frac{\text{km/hectare}}{10,000 \div \text{Row spacing (m)} \div 1000}$$

## 5 Litres per Hectare

$$\frac{\text{Litres/Ha}}{\text{Total Litres per Minute} \times 600 \div \text{Row Spacing (m)} \div \text{Speed (km/hr)}}$$

## 6 New Output (litres per minute)

$$\frac{\text{New Output (l/min)}}{\text{Known Output (l/min)} \times \text{New Pressure (bar)} \div \text{Known Output (bar)}}$$

## 7 Time to Spray One Hectare

$$\frac{\text{Time (minutes)}}{600 \div \text{Row Planting Width (m)} \times \text{km/hr}}$$

## 8 Vertical Target Volume

$$\frac{\text{Target Volume(m}^3\text{)}}{\text{Land Area (ha)} \times 2 \times \text{Tree height (m)} \div \text{Row Spacing (m)}}$$

## 19 Actual Litres/Minute per Nozzle

$$\frac{\text{Litres/Minute per Nozzle}}{\text{Total Litres per Minute} \div \text{Number of Nozzles}}$$

## 10 Spray Volume Required per Hectare

$$\frac{\text{Spray Volume/Hectare (litres)}}{10 \times \text{Tree Height (m)} \times \text{Tree Width (m)} \times \text{Spray Volume Factor} \div \text{Tree Row Spacing (metres)}}$$

## 11 Number of Trees per Spray Tank

$$\frac{\text{Tree Number/Spray Tank}}{\text{Spray Tank Size} \times 1000 \div \text{Tree Height (m)} \div \text{Tree Width (m)} \div \text{Row Spacing (m)} \div \text{Spray Volume Factor}}$$



# Useful Formulae for Calibrating Sprayers Assembly Drawings & Parts

The following formulae may be useful when calibrating sprayers for vineyard applications.

## 1 Tractor Speed

$$\begin{aligned} & \text{km/hr} \\ & = \\ & \text{metres travelled in one minute} \div 16.7 \\ & \text{OR} \\ & \text{mph} \\ & = \\ & \text{feet travelled in one minute} \div 88 \end{aligned}$$

## 4 Distance Travelled per Hectare

$$\begin{aligned} & \text{km/hectare} \\ & = \\ & 10,000 \div \text{Row spacing (m)} \div 1000 \end{aligned}$$

## 5 Litres per Hectare

$$\begin{aligned} & \text{Litres /Ha} \\ & = \\ & \text{Canopy Width (m)} \times \text{Canopy Height (m)} \times 30 \times \text{Density Factor} \times 100 \\ & \div \text{Row Spacing (m)}. \end{aligned}$$

## 4 Litres per 100 Meters

$$\begin{aligned} & \text{Litres/100 Meters} \\ & = \\ & \text{Canopy Width (m)} \times \text{Canopy Height (m)} \times 30 \times \text{Density Factor} \end{aligned}$$

## 5 Litres per Hectare

$$\begin{aligned} & \text{Litres/Hectare} \\ & = \\ & \text{Litres per 100 metres} \times 100 \div \text{Row Spacing (m)} \end{aligned}$$

## 6 Litres per Minute

$$\begin{aligned} & \text{Litres/Minute} \\ & = \\ & \text{Litres per 100 metres} \times \text{Kilometres per Hour} \div 6 \\ & \text{OR} \\ & \text{Litres/Minute} \\ & = \\ & \text{Row Spacing (m)} \times \text{Litres/Hectare} \times \text{Kilometres/Hour} \div 600. \end{aligned}$$

## 7 Litres/Minute/Nozzle

$$\begin{aligned} & \text{Litres/Min/Nozzle} \\ & = \\ & \text{Litres per Minute per Row} \div \text{Number of Nozzles per Row} \end{aligned}$$

## 8 Time to Spray One Hectare

$$\begin{aligned} & \text{Time (minutes)} \\ & = \\ & 600 \div \text{Row Planting Width (m)} \times \text{km/hr} \end{aligned}$$

## 9 Actual Litres/Minute per Nozzle

$$\begin{aligned} & \text{Litres/Minute per Nozzle} \\ & = \\ & \text{Total Litres per Minute} \div \text{Number of Nozzles} \end{aligned}$$

## 10 Spray Volume Required per Hectare

$$\begin{aligned} & \text{Spray Volume/Hectare (litres)} \\ & = \\ & 10 \times \text{Tree Height (m)} \times \text{Tree Width (m)} \times \text{Spray Volume Factor} \div \text{Tree} \\ & \quad \text{Row Spacing (metres)} \end{aligned}$$



## **CROPLANDS**

### **AUSTRALIA**

Croplands Equipment Pty Ltd  
ACN 006 450 184

PO Box 2441  
Dry Creek  
50 Cavan Road  
Dry Creek SA 5094  
Australia

Freecall: 1800 999 162  
Freefax: 1800 623 778  
Email: [sales@croplands.com.au](mailto:sales@croplands.com.au)  
Website: [www.croplands.com.au](http://www.croplands.com.au)

### **NEW ZEALAND**

Croplands Equipment Ltd  
PO Box 2004,  
Stortford Bridge, Hastings 4120

Location:  
1422 Omahu Road,  
Hastings 4120  
New Zealand

Freecall: 0800 106 898  
Freefax: 0800 117 711  
Email: [sales@croplands.co.nz](mailto:sales@croplands.co.nz)  
Website: [www.croplands.co.nz](http://www.croplands.co.nz)

Your nearest Croplands Dealer  
can be found in the dealer section  
on the Croplands website