

CROPLANDS

Quantum Mist™ Ultra Tower & Tower



Parts & Operator's Manual

Foreword

Important Information

Section 1

Pre-Operation

Section 2

Sprayer Operation

Section 3

Sprayer Calibration

Section 4

Lubrication & Maintenance

Section 5

Trouble Shooting

Section 6

Assembly Drawings & Parts Listings

Section 7

Foreword

About This Manual

This manual provides assembly, setting up, operating and maintenance instructions for the Croplands Quantum Mist™ sprayer.

Some features explained in this manual may not be installed on your sprayer.

Please pass on this manual with the sprayer at the time of resale for usage by the new owner.

Terminology

These terms/symbols used throughout this manual:

- **NOTE** - to convey useful operating information.
- **CAUTION** - to highlight potential injury or machinery damage.
- **WARNING** - to stress potential dangers and the importance of personal safety.

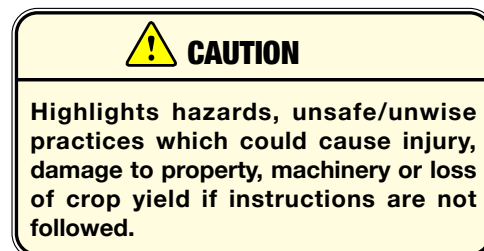
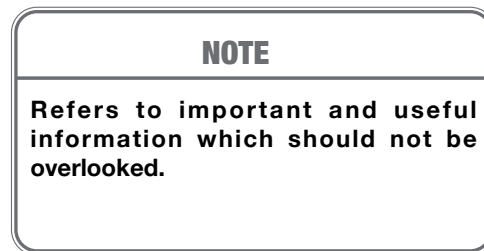

Before Operating Your Sprayer

- 1 Before attempting to use your sprayer, make sure you **read the Operator's Manual** and properly understand:
 - All Safety Issues.
 - Assembly & Installation instructions.
 - Calibration of the sprayer.
 - Sprayer Operation.
 - Sprayer Maintenance.
- 2 Read and follow instructions on chemical manufacturers' labels.
- 3 Always wear applicable protective clothing.

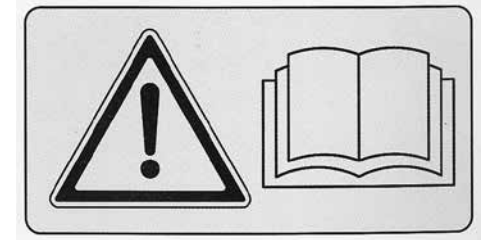

Read and understand this Operators' Manual before operating the sprayer.



Introduction	1.2
General Specifications	1.3
Warranty Policy	1.4
Safety	1.5
Shipping Information & Product ID	1.6



Sean Mulvaney, General Manager of Croplands

Congratulations on the purchase of your new Croplands sprayer.

Croplands have been in the business of building and selling spraying equipment since 1972. For over 40 years we have been supplying sprayers to farmers, contractors, growers and all our customers involved in growing crops and in the control of pests and diseases.

Croplands is a wholly owned subsidiary of Nufarm Ltd, the largest supplier of crop protection chemicals in Australasia, and one of the fastest growing global suppliers world-wide.

At Croplands, we pride ourselves on our commitment to supplying machinery that is at the forefront of the industry's needs. We believe we can back up our products and through constant research and development, bring to you the best equipment you can find.

We welcome any feedback from you about our equipment.

On this page you will find our contact details, and locations where our staff can be reached during business hours.

After hours, you can e-mail us and expect a reply the following morning.

Please read this manual in its entirety before you operate your sprayer. This will ensure you have a trouble-free start up.

In this manual you will find the parts listings you need should you have any breakdowns in the future.

Bear in mind that over time, some parts may become obsolete or be replaced with better options. You can contact us for alternative options if this is the case.

We trust you will get years of good use from your Croplands Sprayer.

Yours sincerely

Sean Mulvaney
General Manager

Contact details:

AUSTRALIA

Croplands Equipment Pty Ltd
ACN 006 450 184
PO Box 2441, Dry Creek
50 Cavan Road, Dry Creek
S.A. 5094

Australia

Freephone: 1800 999 162

Freefax: 1800 623 778

e-mail: sales@croplands.com.au

website: www.croplands.com.au

NEW ZEALAND

Croplands Equipment Ltd
PO Box 2004
Stotford Lodge, Hastings 4120,
1422 Omahu Road,
Hastings 4120
New Zealand

Freephone: 0800 10 68 98

Freefax: 0800 11 77 11

e-mail: sales@croplands.com.au

website: www.croplands.com.au



4000 litre Quantum Ultra Tower.

General Description & Specifications

The Quantum Mist™ Tower sprayer comes in two basic configurations - the Tower with 6 heads and the Ultra Tower with 8 heads.

Each machine has specific parts and chassis differences covered in this manual. The basic system and components are the same for all configurations.

The Quantum Mist™ uses individual, hydraulically driven spray heads with SARDI 5-blade fans to give the maximum possible coverage in grapes and dwarf tree crops.

Using slower moving, high volume air, which is adjustable within the speed range, the heads are targeted to the canopy to make use of the turbulent air and low drift characteristics.

2000 litre Quantum Tower.



QuantumMist_Tower OM 0313 - Revision 3

Tank Sizes

2000, 3000 and 4000 litre tanks are available Impact resistant, UV-stabilised polyethylene tank.

Calibrated sight gauge, flip-open filling lid with filling strainer & 1 ¼" drain valve from large sump. Quick fill and suction probe fitted as standard. 4000 litre with 80 litre flushing tank. (Separate 15 litre fresh water tank).

Fans

Six or eight individual axial-type fan heads, hydraulically driven simultaneously from tractor hydraulics or self-contained oil supply. Rotomoulded fully integrated cowl for light weight & impact resistance. Fully enclosed sealed bearings.

The 5-blade fan has been scientifically designed for maximum air efficiency in the agricultural environment with excellent characteristics for canopy spraying.

Eight fully adjustable nozzles, incorporated into the cowl design, provide maximum flexibility with liquid application rates.

Hydraulic System

An integrated hydraulic control block takes care of all hydraulic functions and includes the main pressure relief valve, anti-cavitation valve, soft-start mechanism, two test ports (pressure and return) and the main hydraulic adjustment valve for the operator to adjust the fan RPM as required.

This control block feeds the fan circuits, which are suited to each machine.

Tractor Oil Supply & Hydraulic Control

Tractor supplied oil system requires 80 litres/min @ 2750 psi to run fans at 2700 RPM. Hydraulic oil cooler & soft-start mechanism is fitted. Hydraulic control block includes pressure regulator, check valve for safety, ½" pressure line system and ¾" return line and case drain outlet.

Two sets of tractor remotes are required – One set for tower fold, 2nd set for hydraulic drive. Optional in-cab electric fan speed adjuster (requires HV4000 controller).

Optional Independent Oil Supply (Fully Enclosed)

A 120-litre oil tank sprayer mounted with selfsteering drawbar linked to sprayer. PTO-drive to oil supply pump via step-up gearbox. Liquid pump is driven by tractor oil supply & requires 55 to 65 l/min oil flow depending on liquid pump size. Two separate sets of tractor remotes required - one set to drive liquid pump & one set for folding Tower.

Nozzles

Standard with eight ceramic conejets on adjustable nozzle bodies. Optional adjustable double nozzle bodies for sixteen nozzles per head if required.

Each nozzle is totally adjustable to optimise penetration, and is integrated within the cowl design. Spray rate capability for the Quantum Mist™ is from 150 to 3000+ L/ha.

Pump & Drive

Standard with an AR 250/135 combination positive displacement diaphragm pump (250/135 l/min measured at open flow, zero pressure) for liquid supply. AR135 is for auxiliary purposes (agitation etc).

Standard PTO shaft (SH4AG/1200) for standard model. PTO shaft (SH5AG/1200) for Power Pack model.

Agitation

Twin super-flo venturi agitators and bypass agitation.

Filtration

Filling lid strainer, large suction filter, pressure filter & optional nozzle filters.

Chassis

Hot-dipped full-length chassis with pullout step. Self steer drawbar standard.

Boom/Mast

Hydraulically folding top section for transport. Hydraulic width adjustment optional. See factory fitted options.

Controls

Standard with 4-section in-cab electric controls. Optional HV4000 Controller c/w 4 section Arag motor valves.

Wheels

Depending on model, wheel options are:

- 11.5/80 x15.3 wheels with tubeless tyres
- 400 x 15.5 flotation wheels & tyres
- Tandem axle simplicity-suspension assembly with 15" landcruiser wheels and tyres or 11.5/80 x 15.3 wheels with tubeless tyres.

Wheels/Axle Assembly

Standard with single axle, suspended, with 400 x 22.5 flotation tyres. Optional tandem axle suspension with four 11.5/80 x 15.3".

Power Requirement

Approximate power required at the PTO is minimum 60 kW on flat terrain.

Dimensions

4000 litre - 4.3m L x 2.0m W x 2.95m H (boom folded)

Options

Options include electric or auto-spray rate controls, self-tracking drawbar, wheels as listed above, hydraulic fold and upper arm adjustment.

Chemical suction probe, quick-fill system, hydraulic pressure filter.

8 x additional nozzles on double-nozzle bodies per head.

A self contained, PTO driven, hydraulic system for fan drive is also available.

Machine specifications are subject to change without prior notification.

Warranty Policy

Each sprayer will be delivered with a Warranty & Pre-Delivery Booklet which includes:

- the Sprayer's unique serial number,
- the Sprayer's specification sheet,
- a pre-delivery checklist and
- outlines the Croplands Warranty policy.

Always contact your Croplands Dealer first and foremost for warranty matters.

NOTE

For full conditions of warranty and warranty policy, please see the Warranty & Pre-Delivery booklet provided with this sprayer.

CROPLANDS

**SPRAYER SPECIFICATIONS
WARRANTY & PRE-DELIVERY
HORTICULTURE**

WWW.CROPLANDS.COM.AU

STOP
BEFORE COMMENCING
operation, **ENSURE** you read
& understand this manual, its
contents, and any additional
information supplied.

GP-WARH-A | updated Jan 2021

Safety First

Please read and understand all supplied manuals, guides and safety decals before operating this sprayer. This includes the **Croplands Operators Safety Manual** – as pictured here.

This manual is available on the Croplands Web site, or for printed versions contact Croplands customer support and ask for part number GP-SAFE-A (or later version if available).





Use tie-down points provided when transporting.

Shipping Information

The following shipping information is provided but variations can occur without prior notification.

Approx Weight

Model	Boom	Dry Weight (kg)
2000	6 head	740
2000	8 head	780
3000	6 head	830
3000	8 head	920
4000	6 head	870
4000	8 head	980

Maximum Towing Speed

Do not exceed 25 kph when towing on roads.

Dimensions (Approximately)

Model	Boom (folded)	L(m)	W(m)	H(m)
2000HS	6 head	4.5	1.4	2.7
2000XL	6 head	4.1	1.5	2.9
3000	6 head	4.4	1.7	2.9
3000	8 head	4.4	1.8	*2.75
4000	6 head	4.4	2.0	2.7
4000	8 head	4.4	2.0	*2.75

*Note: Tower folded



2000 litre Quantum Mist.

Product Identification

Always use the serial number of the Quantum Mist when requesting service information or when ordering parts.

Early or later models (identification made by serial number) may use different parts, or it may be necessary to use a different procedure for specific service operations.



Quantum Mist Serial Number (A)

Quantum Mist Serial Number Plate

The Quantum Mist Serial Number Plate is located on the main frame at the front of the left hand wheel (A).

This plate shows name of manufacturer, serial number, product code and date of manufacture.

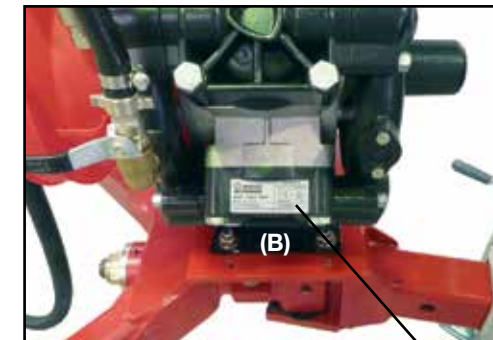

AR Pump Serial Number (B)

Pump Serial Number Plate

The Pump Serial Number Plate is located on the pump (B).

This plate shows name of manufacturer, serial number, type of pump, year of manufacture, maximum flow rate and maximum working pressure of the pump.

Hook-up	2.2
Unhitching	2.8
Pre-Operation Check	2.9
Hydraulic Fan Layout Circuits	2.17



4000 litre Quantum Ultra Tower.



Optional self-tracking drawbar.



Hitch fitted in the lower position.



Loosen the bolts and locking nuts that hold the hitch.

Assembly Instructions

The Quantum Mist™ is supplied fully assembled with the following components requiring some assembly after shipping from the factory:

- 1 Connect the Quantum Mist™ and PTO shaft to the tractor (see pages 2.4 - 2.5).
- 2 Fit the hydraulic hoses to the tractor.
- 3 Fit the spray controller to the tractor:
 - Manual Controls
 - Electric Controller
 - Auto Rate Controller (if ordered).
 - Flowtrak Monitor (if ordered).
- 4 Fit the Boom controls to the tractor (if purchased).

2000 litre Quantum Tower.



1 Connect the Quantum Mist to the Tractor

The Quantum Mist™ must be connected to a suitable tractor, making sure the drawbar and PTO shaft are fitted according to the instructions that follow:

- 1 Align drawbars of tractor and Quantum Mist™, then insert & lock the drawbar pin in position ensuring it cannot come out while transporting or operating.
Lift up and/or remove the hitch jack for sprayer operation.
- 2 Check the Quantum Mist™ is level fore and aft. The sprayer should be slightly lower at the front (up to approximately 3 degrees). If not make the necessary adjustments to tractor and/or sprayer drawbars and axle to achieve level position (see pages 2.3 - 2.4).

NOTE

When connected to your tractor drawbar, the Quantum Mist should be level or slope slightly downwards at the front.

Hitch Adjustment

The Quantum Mist™ standard hitch can be adjusted for height and length to match your tractor drawbar.

1 Height Adjustment

To adjust the height of the Quantum Mist™ hitch:

- a) Make sure the Quantum Mist™ cannot roll.
Support the front of the frame and remove the hitch jack.
- b) Loosen the locking nut and bolt under the Quantum Mist™ hitch.

Hitch fitted in the upper position.



- c) Remove the nut and then the bolt that goes through the hitch.
- d) Slide the hitch out of the Quantum Mist™ frame, turn it the other way up and then slide it back into the frame.

- e) Replace the bolt through the hitch and then the locking nut.
- f) Retighten bolt and the locking nut under the Quantum Mist™ hitch.
- g) Refit the hitch jack.
- h) Connect trailer towing safety chains (not on self steer drawbars).

NOTE

When connected to your tractor drawbar, the drawbar pin connecting the tractor and Quantum Mist™ should be centred between the two universal joints of a PTO shaft (see illustration on page 2.4), except where a constant velocity drive shaft is being used.

Where a constant velocity drive shaft is used, the towing pivot point should be as close as possible to the constant velocity joint of the driveshaft (see the illustration on page 2.5).

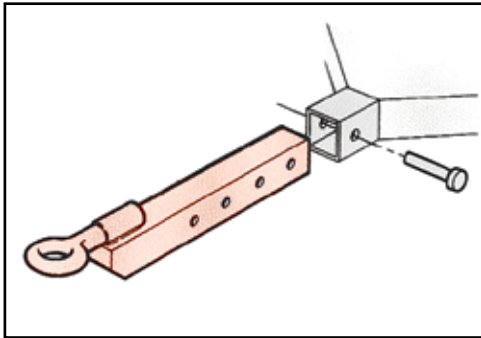

Select the hole position to set hitch length.

2 Length Adjustment

To adjust the length of the Quantum Mist™ hitch:

- Make sure the Quantum Mist™ cannot roll.
Support the front of the frame and remove the hitch jack.
- Loosen the locking nut and bolt under the Quantum Mist™ hitch.
- Remove the nut and then the bolt that goes through the hitch.
- Slide the hitch in out of the Quantum Mist™ frame to the length required.
- Replace the bolt through the hitch and then the locking nut.
- Retighten bolt and the locking nut under the Quantum Mist™ hitch.



Optional self-tracking drawbar.

Self-Tracking Drawbar

If your Quantum Mist is fitted with a self-tracking drawbar, ensure the pivot points are greased regularly (every spray-round).

To adjust the self-tracking drawbar length, follow the steps as instructed for "Length Adjustment" (shown left) for the standard drawbar hitch.

With the pump mounted on the top of the self-tracking drawbar, the PTO shaft will remain unchanged in length & direction during turning.

Ensure the drawbar is cut to the correct length for your tractor prior to operation & that the PTO shaft is greased every 4 hours during operation.

See your dealer about cutting the PTO to the correct length.

For more instruction on the self-tracking drawbar, see page 2.6.



Spring suspension axle.

Optional Suspension Axle

The two row Quantum Mist is fitted standard with a spring suspension axle.

The axle can be adjusted along the chassis if necessary for weight balance and stability.

Tandem axle options are available.

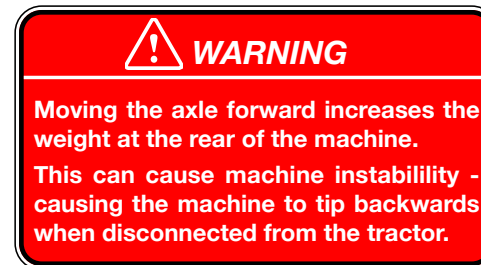

Optional Tandem Axle.



Optional self-contained hydraulic system & self-tracking drawbar.

Self-Contained Hydraulic Option

If your Quantum Mist is fitted with a self-contained hydraulic option, ensure the pivot points are greased regularly (every spray-round).

Axle spring.

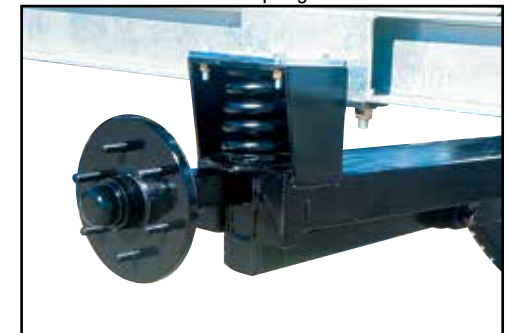



Connect the Quantum Mist™ to the tractor.

2 Fit the PTO Shaft

The PTO shaft is inspected at the factory and is disconnected and packed for transit.

Follow the instructions below to fit the PTO shaft onto the Quantum Mist™ after transit:

- 1 Remove the PTO shaft which is strapped to the Quantum Mist™ frame.
- 2 Check the PTO shaft has not been damaged in transit.
- 3 Grease the universal joints, telescoping shafts & safety cover bushes.
- 4 Measure and fit the PTO to the Quantum Mist ensuring the locking pin is correctly located.

Make sure you read and understand

NOTE

Full instructions are given on the following pages to ensure the PTO is set-up correctly BEFORE use.

If you are inexperienced in the procedures, this step should be carried out by your dealer.

NOTE

Incorrect hitching of PTO shaft will result in excessive pump vibration and damage to the pump.

NOTE

IMPORTANT: Do not allow more than 10% difference in the two halves of drawbar length. If more than 10% difference occurs, a wide angle shaft must be used.

CAUTION

Ensure that the drive shaft is the correct length to avoid any "butt up" damage to the pump.

"Important factors for fitting the PTO shaft" on the next page.

Cutting the PTO shaft to length requires knowledge of this procedure. If you have not carried out this procedure before, ensure your dealer carries out this important step.

- 5 Before operating the drive shaft, be sure that all safety guards are in place & safety chains are securely fitted.
- 6 **Do not exceed maximum RPM of the pump or gearbox (550 RPM).**

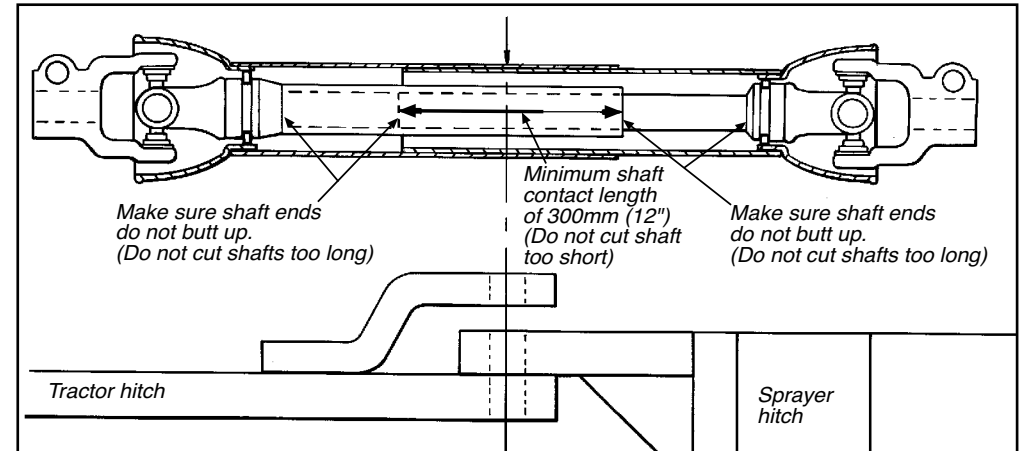

On Standard PTO shafts, the drawbar pin connecting the tractor & Quantum Mist should be centred between the two universal joints of the PTO shaft. For wide angle (constant velocity) shafts, see page 2.12 for alternative settings.

Important Factors when Fitting the PTO Shaft

The following three factors must be correct to avoid pump damage and maximise PTO operating life:

- 1 When travelling straight ahead, the point at which the sprayer drawbar pin is joined to the tractor should be as close to halfway as possible between the universal joints of a Standard PTO shaft, as illustrated.

The tractor is then able to make maximum turns with minimal bending of the universals.

- 2 When the tractor is towing the sprayer straight ahead, the two telescopic sections of the power take-off shaft are at maximum extension.

When turning or crossing an inversion, the telescopic shaft length will vary.

Standard PTO

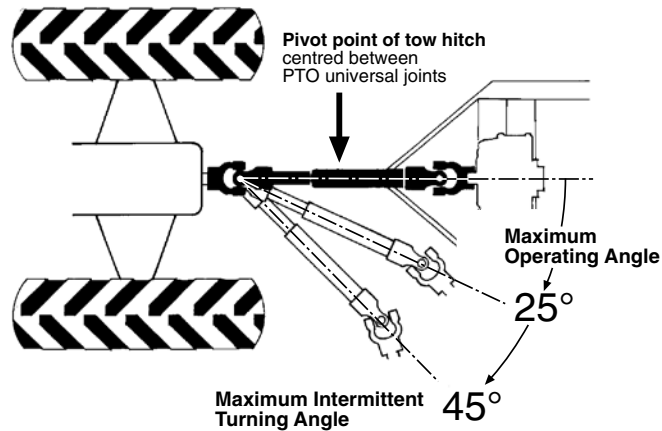

Optional Wide Angle (Constant Velocity) PTO

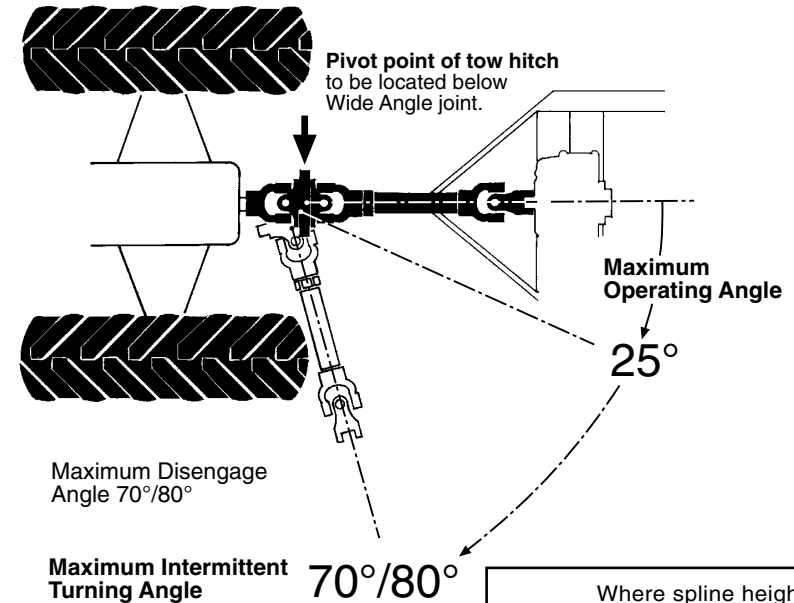

- The height difference between the tractor PTO spline and the PTO spline of Quantum Mist should not be more than 100mm.

This ensures PTO joint angles are approx equal and do not exceed limits. If greater than 100mm, a wide angle (constant velocity) PTO should be used.

See Hitch height adjustment instructions on page 2.2.

Heed the Operating Limits of the Standard PTO Shaft

The standard Quantum Mist is fitted with a STANDARD PTO shaft.

The maximum intermittent turning angles of the Standard PTO shaft is only recommended where should not exceed 45° turning angle of the PTO.

Standard PTO Operating Limits

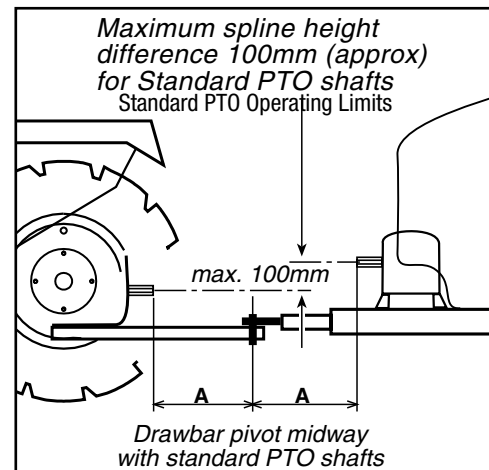

Optional Wide Angle PTO

The wide angle (constant velocity) PTO or swivel drawbar must be used where tight turning requires greater than 45° turning angle of the PTO shaft.

Where height variance between the tractor output spline and Quantum Mist™ input shaft is greater than 100mm, a wide angle (constant velocity) PTO must be used.

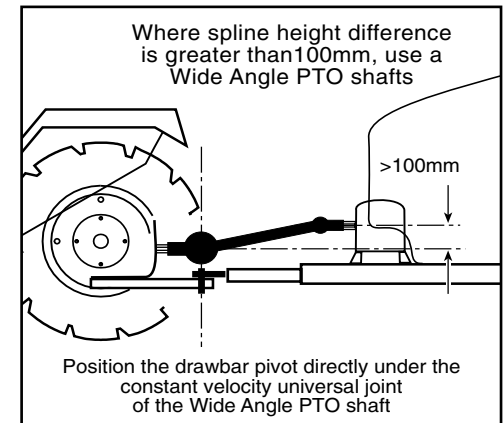

CAUTION

Pump warranty is not valid for damage caused by incorrect PTO shaft mounting.

WARNING

Always operate the PTO fitted to your Quantum Mist™ within the specified limits. Follow the information on pages 2.4 - 2.5.

Failure to operate the PTO as instructed can result in serious damage to the pump, PTO and any components connected to the drive train of the tractor and Quantum Mist. Incorrect operating will void warranty claims.



Optional self-tracking drawbar.



Failure to lock linkage arms may cause damage or injury.



3/4" female back-to-tank return fitting supplied with the Quantum Mist.



Connect hydraulic hoses to the tractor.

Optional Self-Tracking Drawbar

The self-tracking drawbar can be used where tight turning requires greater than 45° turning angle of a PTO shaft and in lieu of the wide angle PTO option.

It is also suitable for ensuring the sprayer wheels track on the same lines as those of the tractor to make row exit & entry easier.

Follow the instructions below to connect the self-tracking drawbar to the tractor:

- 1 Connect the tractor linkage arms to the self-tracking drawbar linkage pins Cat 1 & fit the holding clips.
- 2 Ensure the sprayer chassis is

horizontal (it may be up to approximately 3 degrees lower at the front).

- 3 Fit locking bars to lock the tractor linkage arms into position.

Important: Locking bars must be fitted to tractor linkage arms to prevent the sprayer tipping up and causing damage or injury.

- 4 Fit the PTO shaft to the tractor and to the sprayer pump.

Ensure the PTO shaft is cut to the correct length.

NOTE

When connected to your tractor drawbar, the drawbar pin connecting the tractor and Quantum Mist™ should be centred between the two universal joints of a PTO shaft (see illustration on page 2.4), except where a constant velocity drive shaft is being used.

Where a constant velocity drive shaft is used, the towing pivot point should be as close as possible to the constant velocity joint of the driveshaft (see the illustration on page 2.5).

3 Connect the Hydraulic Hoses to the Tractor

Once the hitch & PTO adjustments are complete, it is important to correctly set up the hydraulic supply for the tractor.

Your dealer will carry out this step to ensure no damage or warranty issues will result from incorrect set up.

A small charge may be incurred for this procedure.

A 3/4" return fitting is supplied with your Quantum Mist.

This is the DIRECT BACK-TO-TANK fitting required to ensure there is no back-pressure on the oil return from the Quantum Mist sprayer.

NOTE

It is recommended to mark each of the hoses and the tractor remotes with cable ties or coloured markers once the hoses are in place. This will ensure that any operator in the future can easily hook up your Quantum Mist sprayer in the future.

On all models, it is important that these steps are done - to make it easy for you to use your sprayer, and to protect the sprayer's hydraulic system:

- 1 Ask your dealer to fit the 3/4" female return coupler direct back-to-tank.
- 2 Decide on the best supply remote on your tractor to use for oil supply for the fan system.
- 3 Plug the 1/2" oil supply line coupling to your selected remote and ensure the hydraulic line does not foul your PTO or any working parts at the rear of the tractor.

Allow sufficient slack in the hydraulic line for turning.

- 4 Hook up the 3/4" return line to the tractor.

As with the pressure line, ensure there is sufficient slack & no interference with tractor working parts.

For instructions on the operation of hydraulic systems, refer to pages 2.10-2.11.

! WARNING

Locking bars must be fitted to tractor linkage arms to prevent the sprayer tipping up and causing damage or injury. Failure to lock the tractor linkage arms may cause damage or injury.

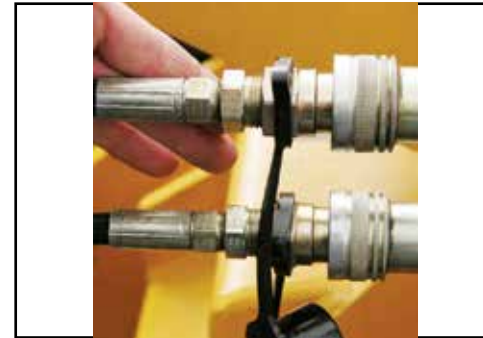
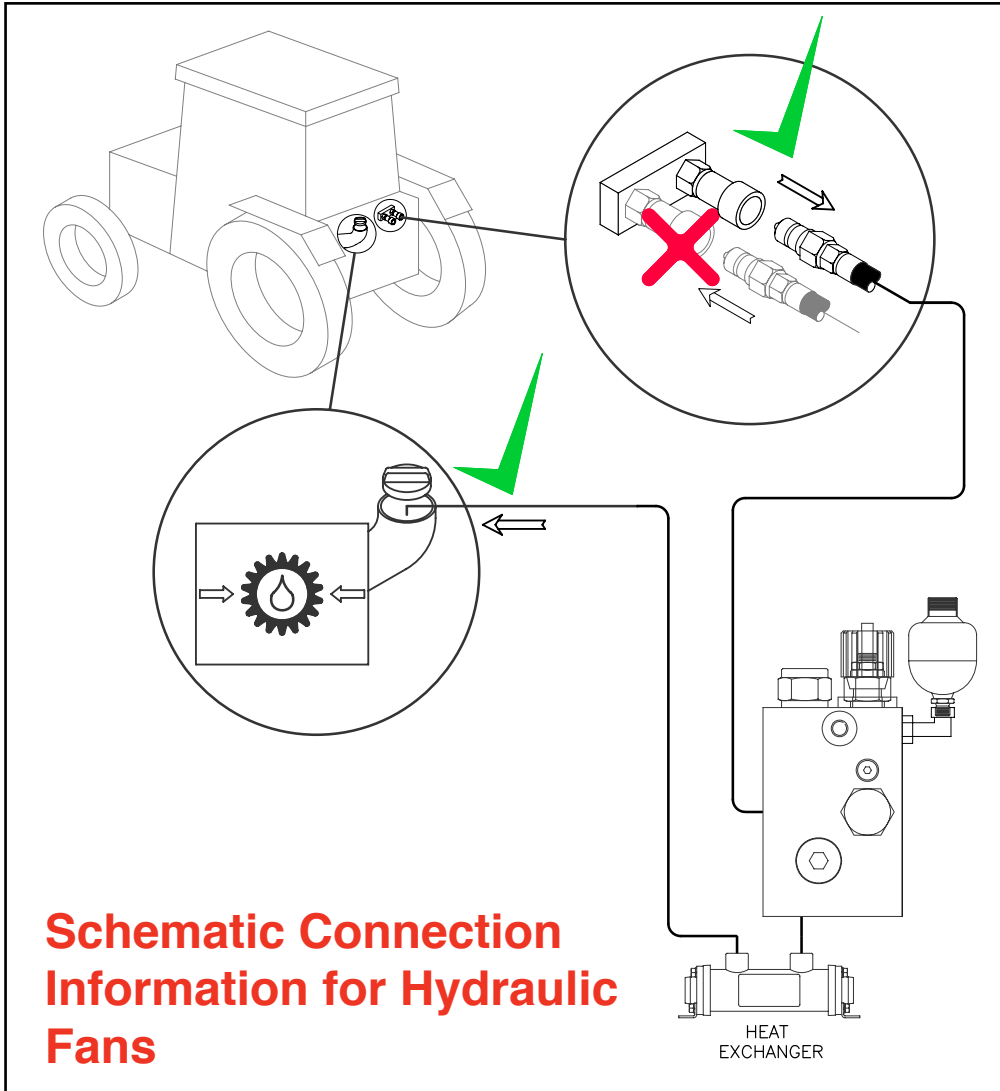

Connect the Tower fold/unfold hoses to the tractor (Fold Tower models only).

Connect the Boom Arm Hydraulic Hoses (Fold Tower models only)

Follow the steps below to connect the boom arm fold/unfold hydraulic hoses (Fold Tower models only):

- 1 As with the hydraulic oil supply lines, select the appropriate remotes at the rear of the tractor for the fold/unfold hydraulic supply hoses.

Plug the hoses in, again ensuring there is no interference with tractor working parts or the PTO shaft, and ensure there is enough slack in the hoses to allow easy turning.

- 2 The boom arm adjust function has an electric selector valve on the sprayer to select left from right with an in-cab control.



In-cab control switch for fold/unfold and wiring connector.

Fit the Electric In-Cab Switch for the Upper Boom (Option only)

Follow the instructions below to connect the electric in-cab switch for left/right fold & unfold of upper arms:

- 1 Unpack the switch box and secure it in a convenient location in the tractor cab.
- 2 Run the power cable to for the in-cab control switch to a reliable power source. This switch requires good power, so direct to battery is recommended.

Ensure the RED wire is attached to the positive terminal & the BLACK wire to negative.

- 3 Connect the loom from the cab to the loom from the sprayer and ensure the wiring cannot interfere with the PTO shaft or any tractor functions.



Electric controller.



Auto Rate Controllers



Flowtrak monitor.



Attach & adjust hitch jack before removing drawbar pin.

4 Fit the Controller to the Tractor

Follow the appropriate instructions to fit the controller to the tractor.

Electric Controller (if ordered)

When ordered, the electric controller has been fitted and fully tested at the factory but has been disconnected and packed for transit.

Follow the instructions below to fit the unit after transit:

- 1 Unpack the electric controller from the Quantum Mist.
- 2 Connect the electric controller couplings together, and fit the controller console onto the tractor in a convenient & safe location for the operator.
- 3 Follow the electric controller instructions to connect the unit power connections to the tractor battery.
- 4 Follow instructions to test, calibrate and operate the controller.

Auto Rate Controller (if ordered)

When ordered, the Auto Rate Controller has been fitted and fully tested at the factory but has been disconnected and packed for transit.

Follow the instructions below to fit the unit after transit:

- 1 Unpack the Auto Rate Controller from the Quantum Mist™.
- 2 Connect the Auto Rate Controller couplings together, and fit the controller console onto the tractor in a convenient and safe location for the operator.
- 3 Locate the Auto Rate Controller operators manual and follow the instructions to connect the unit power connections to the tractor battery.
- 4 Follow the instructions in the Auto Rate Controller operators manual to test, calibrate and operate the controller.

Flowtrak Monitor (if ordered)

When ordered, the Flowtrak monitor has been fitted and fully tested at the factory but has been disconnected and packed for transit.

Follow the instructions below to fit the unit after transit:

- 1 Unpack the Flowtrak monitor from the Quantum Mist™.
- 2 Connect the Flowtrak monitor couplings together, and fit the monitor console onto the tractor in a convenient and safe location for the operator.
- 3 Follow the Flowtrak monitor instructions to connect the unit power connections to the tractor battery.
- 4 Follow instructions to test, calibrate and operate the monitor.

Unhitching the Quantum Mist from the Tractor

- 1 Locate sprayer on level ground and block the wheels so that sprayer does not roll when drawbar pin is removed.
- 2 Disconnect PTO shaft, hydraulic hoses, hydraulic & spray controllers from the tractor.
- 3 Attach and adjust the hitch jack and then remove the drawbar pin.
- 4 Ensure caps for the hydraulic fittings are utilised to prevent dust & dirt entering you tractor hydraulic system next time you operate your Quantum Mist.
- 5 Put caps (supplied) on the loom plugs if you have the Auto Rate Controller fitted.

Model	Single Row	Single Row
No of heads	6	8
Oil requirement	33 l/min @ 2500 psi*	44 l/min @ 2500 psi*
*As tested at the hydraulic control block – see “testing hydraulic pressure, Step 3” in this section.		

Tractor hydraulic requirements.

Check the Fan Hydraulics

1 Tractor Oil Supply (standard)

The hydraulic circuit on the Quantum Mist is powered from the oil supply of your tractor.

The table above shows the oil requirements, at the tractor remotes, for each model of Quantum Mist.

The oil flow & pressure may be adjusted once the maximum pressure is set, using the flow adjustment valve.

This allows air speed and volume to be adjusted to suit the canopy size and density as the plants grow during the season.

Less air is required at certain canopy growth stages and/or plant ages.



Auxillary heat exchanger.

The Quantum Mist is fitted with an auxiliary heat exchanger to ensure oil is cooled before it is returned to the tractor.

The tap (shown above) on the UCM control bank must be left in the “ON” position to ensure the heat exchanger is supplied with liquid flow.

A cable-tie is fitted at the factory to hold this tap on the ON position.



Liquid supply to heat exchanger with tap cable-tied in ON position.



Hook up the hydraulic supply & return lines to the tractor.



Ensure the manual pressure/flow valve is wound-out fully.



Loosen the lock-nut on the PRV and adjust with hex key



Set maximum pressure on the PPT port to ...

The following steps must be performed by your dealer, on your tractor:

It is recommended you follow the steps with you dealer to ensure you understand the process for future reference.

Although this procedure is already done at the factory, each tractor is different and will require adjustments on the sprayer.

Step 1

Connect the hydraulic hoses to the tractor. The larger hose (3/4") is the RETURN hose, and must be fitted into the 3/4" hydraulic fitting supplied and fed directly back to tank.

The setup of the 3/4" back-to-tank female hydraulic fitting will be done by your dealer.

The pressure line is the smaller diameter hydraulic hose with a 1/2" male hydraulic fitting on the end.

This is connected to the remote of your choice and is the main oil supply to the sprayer, from the tractor.

Step 2

Engage the hydraulic remote lever in the cab that corresponds to the remote you are using for your fan hydraulic supply.

Ensure you tractor revs are operating at the recommended RPM to achieve required oil flow/pressure from the tractor.

In general, if the oil pump on the tractor is in good condition, this can be achieved at about 60% of full power. After 5 seconds or so, the fans will start to rotate up to full speed.

Step 3

This step requires specialised tools, so your dealer will show you how & why this is done.

At the side hydraulic control block, attach a test gauge to the pressure test port (marked PPT).

Ensure the manual pressure/flow adjustment valve is wound out fully (anti-clockwise) - this will provide you with maximum manual adjustment range once the manifold oil pressure is set.

Using the correct spanner, undo the lock-nut on the pressure relief valve assembly, and using the correct hexagonal allen-key, adjust the PRV to achieve desired oil pressure.

The standard setting is 2750 psi, with a maximum of 2850 psi.

Tighten the lock-nut and recheck the pressure on the gauge.

Step 4

Your dealer should now check the RPM of the fans to ensure they are operating at 2500 RPM (standard full speed) using an RPM meter.

Check fan speed using an RPM meter.





Plug boom-fold hydraulic hoses into tractor remotes.



Optional PTO driven hydraulic pack.



Optional PTO mounted hydraulic supply.

2 Independent Oil Supply Models (Built Only to Order)

In some situations, an independent oil-supply model of the Quantum Mist is supplied.

If you have taken delivery of this model, the set-up procedures are slightly different than the tractor oil-supply model (standard).

For adjustment of oil pressure, the procedure is the same as for the tractor-supply model.

The pressure will have been *factory set*, and **will not** require adjustment.

However, if adjustment is required in the future (after service work or maintenance), the procedure for setting the base pressure is the same as is described in steps 3 & 4 on the previous page.

The tractor must be running and the PTO engaged to perform pressure adjustment as the oil pump on the sprayer is driven by the tractor PTO.



Read Operators' Manuals before operating machine.



Check pump oil level.



Check suction filter is clean.



For filling, use the main lid with the basket filter in place.

Pre-Operation Checklist

- 1 Before attempting to use this machine, Read Operator's Manuals thoroughly.
- 2 Read and follow instructions on chemical manufacturers labels.
- 3 Always wear applicable protective clothing.
- 4 Check that all maintenance procedures have been followed.
- 5 Check all plumbing and fittings to ensure they are tight, not damaged or leaking.
- 6 Check PTO shaft is correctly set up.
- 7 Grease the PTO shaft if necessary.
- 8 Ensure the PTO safety chains are fitted securely.

- 9 Check diaphragm pump oil level.
- 10 Check air pressure in the diaphragm pump air chamber is 70 - 100 kPa (10-15 psi). As a general guideline it should be 10% - 20% of operating pressure.

- 11 Check that the suction and pressure filters are clean.

Clean the suction and pressure filters out after initial use, and nozzles if necessary.

- 12 Check overall spraying functions using the:

The Electric controller -
(Refer to "Check Electric Controller Operation" instructions page 2.14).

OR

The Auto Rate Controller -
(Refer to "Check Auto Rate Controller Operation" instructions page 2.15).

Check pump air chamber pressure.



NOTE

IMPORTANT: Clean the suction filter out after initial use.

Whilst all precautions are taken during assembly, it is possible to get filings in the tank and lines. These will accumulate in the suction filter during first use.



Adjust the sprayer pressure with the pressure-control knob.



Test the LEFT/RIGHT operator of the selector taps.



The pump suction valve OPEN to the main spray tank.



Front and rear tank agitator valves in ON position.

Check the Operation of the Quantum Mist

To check the operation of the Quantum Mist, there are three sections to consider:

- 1 Manual-tap controls
- 2 Electric controls
- 3 Auto Spray Rate Controllers (2 options)

For all three pre-operation checks, ensure you have sufficient clean water in the sprayer, and the pump suction valve is open for sourcing liquid from the main tank.

1 Manual-Tap Controls

If your Quantum Mist is fitted with standard manual-tap controls, the UCM Manual Control Unit will come with a remote-mount kit to attach the unit to the tractor.

- a) Fit the control unit to the tractor where the operator can best access it.
- b) Fit the pressure and bypass lines to the controller and ensure they are tight (no leaks)
- c) Wind the pressure control knob anti-clockwise to ensure the sprayer starts up with limited pressure.

- d) Start the pump by engaging the PTO from the tractor and operate at your required revs.
- e) Turn on the LEFT & RIGHT selector taps to start the nozzles spraying.

The fans do not have to be engaged during this process.

Make sure you have your chosen nozzle selection fitted to the sprayer so that your application will be correct.

- f) Slowly wind the pressure control knob clockwise until your chosen operating pressure is reached.

Maximum recommended pressure is 12 bar.

- g) Check LEFT/RIGHT operation with the selector taps.

WARNING

Important: Do not have pesticides in the spray tank when checking the sprayer.

NOTE

Maximum PTO speed for the pump is 540 RPM.

It is recommended that a minimum of 400 RPM is used for best results.

WARNING

Always ensure the sprayer controls are turned off, hydraulic fan drive and PTO disengaged when making any repairs or adjustments.

Making adjustments while sprayer is operating can lead to serious injury.



Fit the electric control console in the cab and wire the power cable to the battery.



Test master ON/OFF and LEFT/RIGHT functions.



If fitted, test pressure UP/DOWN switch and ensure maximum pressure is 12 bar.



Adjust pressure control knob (PRV) if required.

2 Electric Controls (Optional)

If your Quantum Mist is fitted with electric controls, the control panel and wiring loom for the tractor end will be supplied, ready to connect to the sprayer.

Complete the following steps to test the electric controls:

- Fit the electric control panel in a convenient location for the operator.
- Wire the control console power cable direct to the battery, ensuring the positive and negative polarity is correct.

Check the tank agitator & adjust angle if necessary.



- Connect the control console tractor-end loom to the sprayer-end loom.
- Flick the Master switch to ON, then test the left & right switches by listening to hear if the left/right valves open and close.
- Flick the Master switch to OFF. Start the tractor and engage the PTO to the sprayer.

Ensure you have your chosen nozzle selection fitted to the sprayer so that your application will be correct.

- Turn the LEFT & RIGHT and Master Switch to the ON position. If the sprayer has a pressure UP/DOWN option, press and hold the pressure UP switch (▲) until maximum pressure is reached.

- With the nozzles still going, adjust the main pressure control knob (PRV) on the sprayer itself by winding it in or out until the maximum operating pressure is set to 12 bar on the gauge.

Ensure you have the agitators on during this procedure.

- Back at the control console, check the LEFT/RIGHT operation of the electric valves, and the Master ON/OFF function.

- If the sprayer has a pressure UP/DOWN (▲▼) switch, press the UP/DOWN switch in both directions and check the gauge so that spraying pressure can be controlled from 0-12 bar using the UP/DOWN switch.

If not, re-adjust the PRV on the sprayer.

NOTE

With electric in-cab controls, the electric LEFT/RIGHT valves will bypass the liquid back to the tank when the switch is in the OFF position.

This is to protect the sprayer from any over-pressure during shut-off.

Your electric controls are an important part of the sprayer. Look after them and store them correctly when not in use.

If the electric controls are not functioning, contact your dealer.



Auto Rate Controllers

3 Auto Spray-Rate Controls - MT3405F & HV4000 Models

The Auto-Spray Rate controllers perform the same function as electric controls with the added feature that once the sprayer is being operated, the Auto-Rate Controller will automatically control the output of the



Fit the console in the cab & wire power cables to the battery.

sprayer to match your pre-set spray rate.

To perform a pre-operation check, follow these instructions:

- Fit the Auto Spray-Rate control console in a convenient location in the tractor cab.
- Wire the power cable directly to the battery or appropriate direct-power source.
- Connect the tractor-end loom to the sprayer-end loom and secure the loom plugs so they cannot be



Hold the pressure up switch until maximum pressure is achieved.

damaged during use.

- With the correct choice of nozzles fitted to the Quantum Mist, start the PTO shaft and bring the pump up to your chosen PTO operating speed (between 400 - 540 RPM)
- Power-up the controller by switching ON the power switch.
- Push the MANUAL/START button on the face of the controller so that the word "MAN" or "MANUAL" appears on the screen.

For the HV4000, "MANUAL" will appear in the "Target Rate" box on the screen.

For the purpose of the pre-operation check, the controller will be operated



Test RUN/HOLD and LEFT/RIGHT functions.

in Manual mode.

- Flick the master RUN/HOLD switch to the RUN position and ensure the appropriate LEFT/RIGHT selector switches are ON.

Depending on the number of sections your sprayer has, this will be either 2 or 4 switches on the console face.

- With water now coming out the nozzles, press the "+" or "-" key for 8 - 10 seconds to bring spraying pressure up to maximum.

Check the gauge during this process.

Maximum pressure should be set at 12 bar.

NOTE

IMPORTANT: Read the MT3405F or HV4000 Manual carefully, and enter the calibration values you require to achieve you target spray rate.

WARNING

Do not have pesticides in the spraytank when checking the sprayer.

NOTE

If independent oil supply for the fans is fitted, operate the spray pump at 400 - 540 RPM using the hydraulic flow control.

NOTE

The maximum spraying pressure will vary with different nozzles. We recommend you re-adjust your maximum pressure if you change your nozzle selection.



Test the pressure UP/DOWN with console in Manual Mode (MT3405).



Adjust PRV for Pressure Control.



Read the Manual before operating the Quantum Mist.

- i) If maximum pressure is below or above 12 bar, adjust the PRV valve on the sprayer by winding it in or out until maximum pressure (12 bar) is achieved on the gauge.

- j) Return to the Auto Spray-Rate console and check the LEFT/RIGHT and master RUN/HOLD functions.

If you have problems testing the sprayer, or if any functions are not operating correctly, consult your dealer.

For full and final operation of the Auto Spray-Rate control, read the specific MT3405F or HV4000 manual fully before operating the Quantum Mist.

NOTE

Ensure the tank agitators are ON and operating during the pre-operation check.

NOTE

Additional copies of the MT3405 manual can be downloaded in a PDF file format from the Internet.

For the micro-trak MT3405, log onto www.micro-trak.com and follow the menu.

2 Parallel Sets x 3 Fans in Series

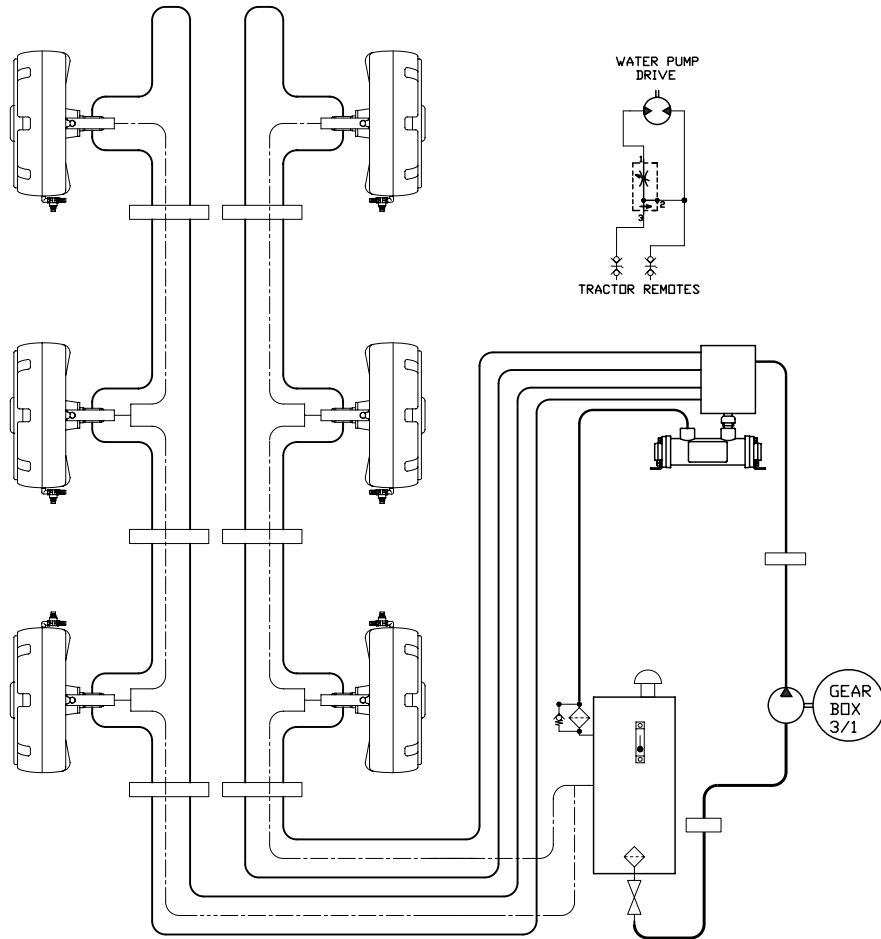

2 Parallel Sets x 4 Fans in Series

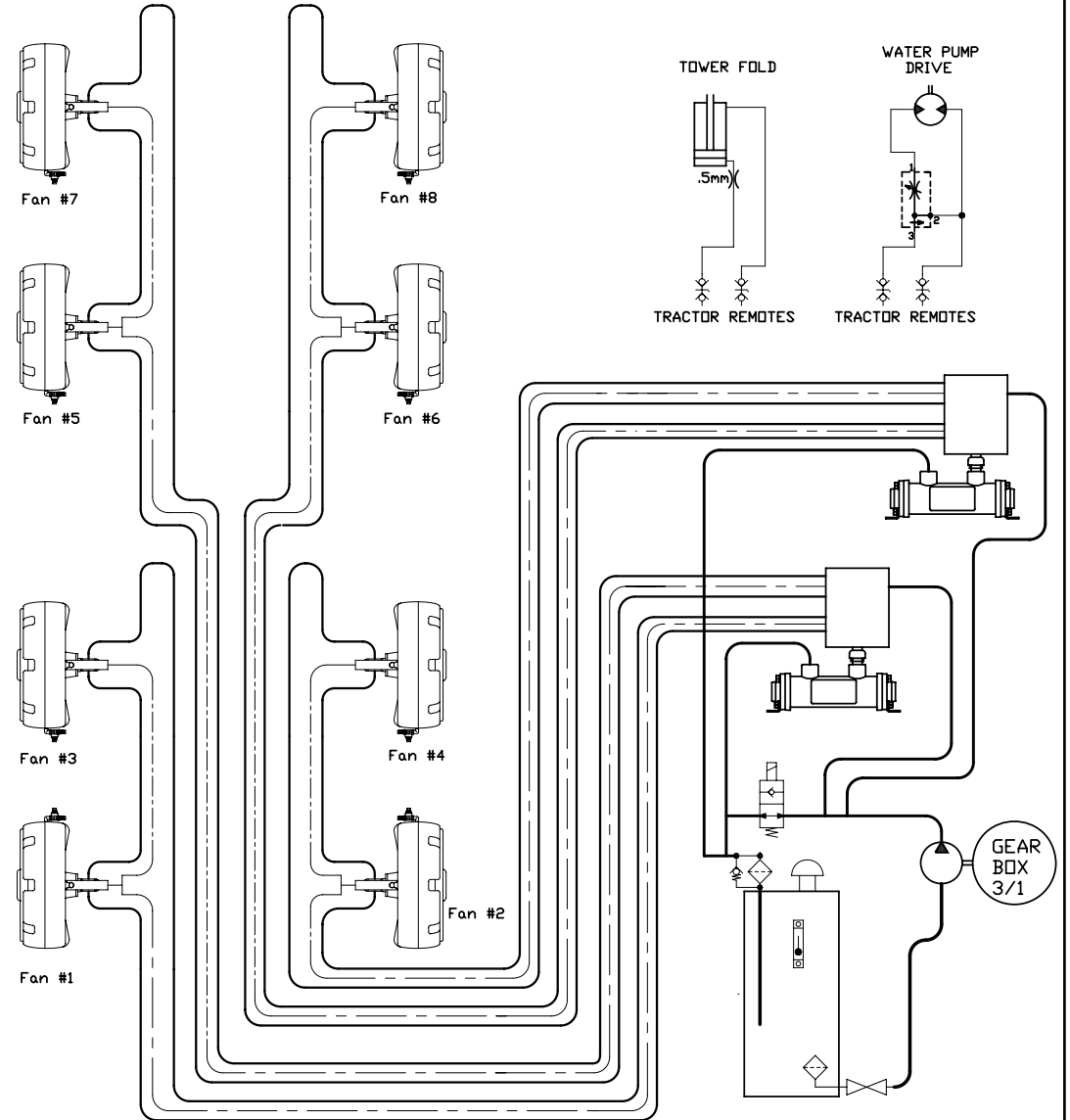

Filling	3.2
Filters	3.3
Chemical Mixing	3.4
Proceed to Spray	3.6
• Operating Pointers	3.6
• Position Spray Heads	3.6
• Adjust Nozzle Settings	3.7
Cleaning	3.8



Open the lid & fill main tank using the basket filter.



Remove the lid shown to fill the flushing tank.

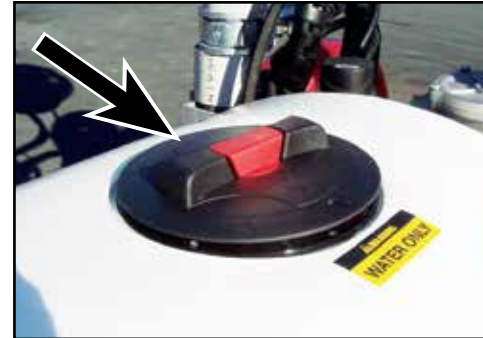

Remove the lid shown to fill the fresh water tank.



CLOSE the pump suction valve before filter cleaning.

Filling the Sprayer

The Quantum Mist features three tanks for easy operation, cleaning and safety.

1 Main Tank

When filling the main tank, open the spray tank lid and fill the tank with the basket filter in place.

Use fresh water (preferably rainwater), free of suspended organic matter or clay. Some chemicals are de-activated when they contact these materials.

Ensure sufficient water quantity to allow correct product blending.

2 Flushing Tank

Use fresh water (preferably rainwater) in the flushing tank. Unscrew the lid (shown above) and fill before spraying.

Replace the lid after filling.

3 Fresh Water Tank

Use only rainwater in the flushing tank. Unscrew the lid (shown below) and fill before spraying.

Replace the lid after filling.

Filters

Filters will ensure that no solids enter the system to block or damage pump or nozzles.

- 1 Always ensure the basket filter is in place when filling the main tank.
- 2 All filters should be cleaned regularly, or after each spraying period.

If the filter screen is damaged, replace with a new screen.

Unscrew & remove the fresh water tank lid.





Thoroughly clean the suction filter and reassemble.

Cleaning the Suction Filter

The suction filter should be cleaned regularly or after each spray tank has been emptied.

To clean the filter:

- 1 Completely stop all sprayer functions.
- 2 Place the pump suction valve in the closed position to shut off liquid from the main tank.
- 3 Remove the outer filter screw and bowl, and then remove the filter and thoroughly clean it.

Check the condition of O-Ring before reassembling the filter.



Clean pressure line filter regularly.

Cleaning the Pressure Filter

The pressure line filter should be cleaned regularly or after each spray tank has been emptied.

To clean the pressure line filter:

- 1 Completely stop all sprayer functions.
- 2 Open the valve at the bottom of the filter to ensure all pressure is removed from the filter.
- 3 Remove the outer filter bowl, and then remove the filter and thoroughly clean it before re-assembling the filter.



Regularly clean nozzle filters (if fitted).

Cleaning Nozzle Filters

Nozzle filters should be cleaned regularly to avoid nozzle blockages.

To clean the nozzle filters:

- 1 Completely stop all sprayer functions.
- 2 Remove the nozzle cap and nozzle, and then remove the filter.
- 3 If necessary remove the seal and nozzle from the cap to clean the nozzle.
- 4 Thoroughly clean the nozzle filter and nozzle before reassembling the units.



Front and rear tank agitator valves in ON position.

Agitation

When chemical is added to the tank, the pump and agitator(s) must be operating at all times to ensure chemical does not settle in the tank.

Check to see that tank agitators are correctly adjusted.

If agitation causes too much foaming in the tank, turn off the agitator.

If chemical settles, through pump break down or other reasons, start up the sprayer after the fault has been rectified, then let the mixture in the tank agitate for a length of time to ensure thorough mixing of the chemical.

NOTE

Be careful not to damage or deform the mesh or gasket while cleaning and refitting the filters and nozzle caps.



Agitator and mixing basket valves CLOSED.



Agitator and mixing basket valves OPEN.



The pump suction valve OPEN to the main spray tank.



Agitator valves OPEN & mixing basket valve CLOSED.

Mixing Basket

A separate chemical mixing basket is provided in the main tank to allow the operator to add and mix chemicals to the main tank while it is filling. This will save down time in spraying operations.

To operate the mixing basket:

- 1 Fill the main tank with the appropriate amount of water.
- 2 Measure the chemical required for the tank mix and place the chemical (liquid, powder or granules) into the mixing basket & close the mixer lid
- 3 Check the pump suction valve (located at the front of the sprayer) is open for sourcing liquid from the main tank.
- 4 Open agitator valves.

5. Open the mixing basket valve.
- 6 Place sprayer controls in start up position by placing the master switch in OFF position.
- 7 Engage PTO and bring the PTO speed up to 540 RPM.
- 8 Pressurise the system and operate the tank agitator by placing the master switch in ON position.
- 9 Allow the chemical to mix into the tank and close the mixing basket valve.
- 10 Keep the PTO engaged and the agitators operating while chemical is in the tank.

The mixing basket assists adding chemicals to the tank.



CAUTION

Always follow chemical label safety instructions.

When handling chemicals always wear protective clothing ie. gloves, face mask, spray suit.

Should chemical come in contact with skin immediately rinse off with water.



Accurately calculate the amount of chemical required.



25 litre measuring bucket.

Calculate Water & Chemical Quantities

Before spraying it is necessary to calculate the exact quantities of water and chemical needed to spray the required area of orchard or vines.

a) For chemical rates expressed in litres or kg per hectare (land area), use the formula:

Chemicals required (litres)

=

Tank Volume (l) x Recommended Chemical Rate (l/ha) ÷ Spray Application Rate (l/ha)

eg.

$$1500 \times 5 \div 400 = 18.75 \text{ litres.}$$

b) For volume of mixture required to spray the selected area, use the following formula:

Tank Volume Required (litres)

=

Area (ha) x Spray Application Rate (l/ha)

eg.

$$18.75 \times 400 = 1500 \text{ litres}$$

Area Covered (ha)

=

Tank Volume (litres) ÷ Spray Application Rate (l/ha)

eg.

$$1500 \div 400 = 3.75 \text{ hectares}$$

c) For chemical rates expressed in litres or kg per 100 litres of water (water volume), use the formula:

Chemicals Required (litres)

=

Tank Volume (litres) x Recommended Chemical Rate (l/100 litres) ÷ 100

eg.

$$1500 \times 3.0 \div 100 = 45 \text{ litres.}$$

NOTE

Important: Be sure to mix only enough spray mixture to cover the area required. Avoid wastage and problems of needless chemical disposal.



Adjust height of fan on inner/outer tube.



Spin mount to move fan closer to canopy, and to allow tilt adjustment.



Adjust mount for tilt (upwards or downwards) in relation to canopy.



Adjust mount for forward/rearward fan adjustment.

Proceed to Spray

Once the chemical mixture is in the tank, proceed to spray:

- 1 Adjust the pressure to correct operating pressure by adjusting pressure (up or down) according to instructions of the controller fitted.
- 2 Turn spray booms ON and OFF as required to spray according to the instructions of the controller fitted.

Operating Pointers

While spraying, continually ensure that:

- 1 Engine and PTO speed are correct.
- 2 Correct operating pressure is being maintained.
- 3 Ground speed is correct and constant.
- 4 Quantum Mist spray heads are operating correctly and aimed toward the target foliage.

Position the Spray Heads

The Quantum Mist spray heads can be adjusted individually for width & direction.

Each head should be individually adjusted to maximise coverage and penetration into the target foliage.

a) Individual Fan Width & Height Adjustment

To individually adjust each Quantum Mist spray head width and height:

- 1 Loosen the clamp bolts.
- 2 Adjust the mast or wing uprights and fan head assemblies up or down & in or out.
- 3 Retighten the clamp bolts after adjustments have been made.
- 4 Repeat steps 1 - 3 as necessary for each fan head assembly.

b) Directional Adjustment

To adjust individual Quantum Mist fan head direction:

- 1 Loosen the cradle-to-upright bolts and adjust the head up or down to suit.
- 2 Retighten the cradle-to-upright bolts.
- 3 Loosen the cradle-to-motor bolts and adjust the head fore or aft to suit.
- 4 Retighten the cradle-to-motor bolts.
- 5 Repeat steps 1 - 4 as necessary for each fan head.



Nozzles adjusted inwards for bunch line applications.



Nozzles adjusted for canopy spraying.



Right & left booms are activated by boom switches 1 & 2. Switch 4 is used to activate the main On/Off dump valve.

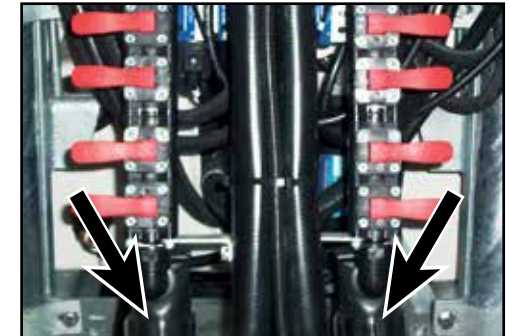

Clean both of the spray head tap filters regularly - before & after use.

Adjust the Nozzle Settings

Eight nozzles are standard on each Quantum Mist spray head.

Each set of nozzles on the spray heads can be adjusted to suit varying application requirements.

Two general nozzle settings are available:

- 1 Adjust both nozzles inwards to concentrate the bulk of the spray pattern into the centre of the airstream.
(Suited to concentrated bunch line applications).
- 2 Adjust each nozzle inwards and outwards consecutively, to give the widest and most uniform spray coverage within the airstream.
(Suited to most applications where widest coverage is wanted).

Optional MT3405

If the optional MT3405 is fitted, the left and right booms are activated by Boom Switches 1 & 2.

Switch 4 is used to activate the main On/Off dump valve, in conjunction with the RUN/HOLD switch.

Regularly Clean Both Filters Below the Spray Head Taps

The two filters located below the spray head taps should be cleaned regularly - before & after each use.

Tighten nozzle swivel to hold setting.



! WARNING

Always wear protective gloves when cleaning filters containing toxic chemicals.



OPEN the Tank drain valve.



Remove & clean the filter element & components.



Tank drain valve CLOSED.

Flushing the Quantum Mist

The Quantum Mist may be equipped with a flushing tank for cleaning the sprayer when changing chemicals, and at the end of the day.

To flush the Quantum Mist:

- 1 Ensure the site for flushing and cleaning the Quantum Mist meets with environmental and statutory regulations.
- 2 Open tank drain valve (valve located at the base of the tank) to drain remaining spray mixture from the tank.

- 3 Open the pump suction valve to the flushing tank.
- 4 Open the mixing basket valve.
- 5 Check that agitator valves are open.
- 6 Place sprayer controls in start up position according to the instructions of the controller fitted (see page ??)
- 7 Engage PTO and bring the PTO speed up to 540 RPM.

All pumped liquid is now being passed through the dump valve back into the tank. The system is not pressurised and tank agitators are not working.

- 8 Pressurise the system and operate the tank agitators.

The pump suction valve OPEN to the flushing tank.



- 9 Adjust pressure to desired operating pressure by adjusting pressure up or down.
- 10 Engage the hydraulics to drive the fan heads.
- 11 Turn the spray booms ON.

Fresh water now flushes through the suction line, suction filter, pump, agitator(s), pressure lines, nozzles and mixing basket.

All water comes into the tank from the flushing tank. Water remaining in the tank drains out of the tank through the drain outlet.

- 12 On completion of flushing, shut down all controls and disengage the PTO and hydraulic fan drive.
- 13 Remove and clean the suction filter and screen, and reassemble.

- 14 Adjust all valves back to operating (non-flushing) mode.

- a) Close mixing basket valve.
- b) Close tank drain valve.
- c) Open pump suction valve to the main tank.
- d) Open the agitator valves.

- 15 Wash/hose down the outside of the sprayer.

NOTE

Ensure the drained mixture is disposed of as required by law. Read chemical instructions.

NOTE

Be careful not to damage or deform the mesh or O-ring while cleaning and refitting the filters.

NOTE

Sulphur & Copper compounds lead to rapid deterioration of metal and polyethylene on you sprayer.

It is strongly recommended that you use an exterior cleaner such as FARM MATE after every spray.

FARM MATE is available from your Spray Shop.



Pump suction valve OPEN for liquid from the main tank.

Using Tank and Equipment Cleaners

If a cleaning agent is required (refer to chemical label), first completely flush the Quantum Mist with water as outlined in Steps 1 - 15 on page 3.9, then:

- 1 Fill the spray tank with fresh water.
- 2 Add cleaning agent into the mixer basket (use according to instructions).
- 3 Open the pump suction valve to the main tank.
- 4 Open mixing basket valve.
- 5 Open the agitator valves.
- 6 Place sprayer controls in start up position according to the instructions of the controller fitted (see the "Pre-Operation" section).

NOTE

Ensure the drained mixture is disposed of as required by law. Read chemical instructions.



Agitator & mixing basket valves OPEN .

- 7 Engage PTO and bring the PTO speed up to 540 RPM.
All pumped liquid is now being passed through the dump valve back into the tank. The system is not pressurised and tank agitators are not working.
- 8 Pressurise the system and operate the tank agitators.
- 9 Adjust pressure to desired operating pressure by adjusting pressure up or down using the toggle switch on the electric sprayer controller.
- 10 Turn the spray booms ON to put cleaner through the spray lines and nozzles.
- 11 If you require the cleaning agent to soak or stand for a period, turn the spray booms OFF and completely shut down the sprayer for a period.

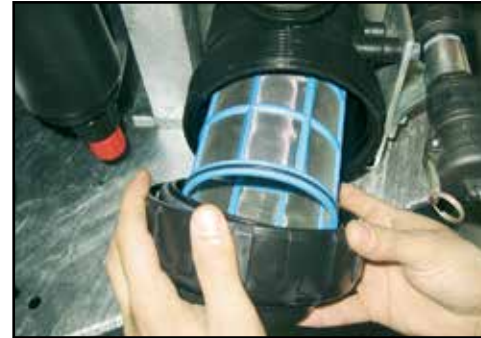

Remove & clean suction filter screen and reassemble.

- 12 When soaking is completed, start the machine following steps to flush the tank and spray lines (see page 28).
- 9 Stop flushing by switching booms off, turning controls off, disengaging the PTO and hydraulic fan drive.
- 10 Open spray tank drain valve and allow cleaning mixture to drain from the tank.
- 11 Completely flush the sprayer with fresh water as outlined on page 3.9.



Fresh water tap for personal safety.

Fresh Water Tank (model dependent)

The Quantum Mist incorporates a fresh water tank on some models for personal safety when operating the unit in the field.

Calibration Procedure	4.2
TXB-VK Conejet Nozzle Chart	4.8
Calibration Work Sheet	4.9



Proper calibration considers all spraying variables.

Applying the correct amount of chemical to a crop is only possible if:

- the sprayer is calibrated correctly.
- the sprayer is operated correctly.
- the sprayer is maintained correctly.

The variables of spray application (distance, time, working width, liquid and chemical volumes) must be measured and controlled accurately to ensure chemicals are applied at the correct rate.

The automatic spray controller measures and controls the variables of speed and flow rate to give constant application.

However proper nozzle selection, checking calibration of nozzles, speed and flow rate as well as correct mixing of chemicals must be done to ensure the accuracy and performance of the sprayer and its controller.

Accurate calibration is essential to ensure uniform application of the recommended dose of chemical to the target.

Proper calibration involves setting up the sprayer (nozzle selection, pressure, speed), calculating chemical and water rates and measuring the performance of the sprayer itself. Only then can you be totally confident in applying chemical correctly.

Fully Automatic Spray Controller (Optional)

The fully automatic spray controller maintains the application rate (set by the operator) when operated in Auto position.

The controller monitors speed of travel (speed sensor) and flow rate (flow meter) and automatically adjusts flow rate (via a servo valve) to maintain correct application rate irrespective of speed variations within the limits of the nozzles used.

IMPORTANT:

- 1 It should be remembered that the spray controller does not eliminate the necessity to measure and check the accuracy of nozzle spray patterns and outputs. These must be checked regularly to ensure correct and uniform application rates because nozzles wear with use.
- 2 Flow meters used by the controller also needs to be checked and calibrated on a regular basis.

On the following page, you will see how to maintain and check your Rapid-check flowmeter. It is recommended you do this regularly during the spraying season.

See the Controller Operator's Manual for detailed information and calibrating procedures specific to your spray controller.



Rapid Check Flowmeter (optional).

Calibration Procedure

For accurate spray rate application, follow this calibration procedure:

Step 1

Ensure Equipment Is In Good Working Order.

Tank, pump, boom, filters and nozzles must be clean, free of leakages and functioning properly.

Follow the pre-operation checklist, maintenance and operating instructions in this manual.

Install, calibrate and operate the spray controller according to the spray controller Installation/Operators Manual.

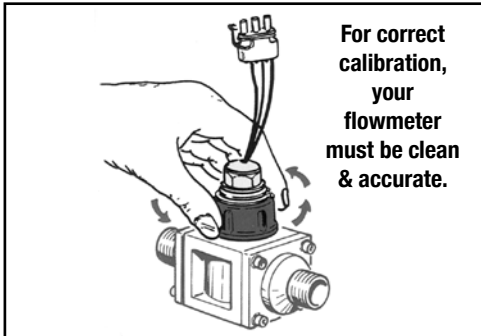

For correct calibration, your flowmeter must be clean & accurate.

Unscrew the the Rapid Check assembly.

Daily Check & Maintenance of Flowmeter (optional)

This is to be performed every day after work is finished:

- 1 Unscrew the assembly that holds the Rapid Check unit in the body.
- 2 Remove the Rapid Check unit from the body.

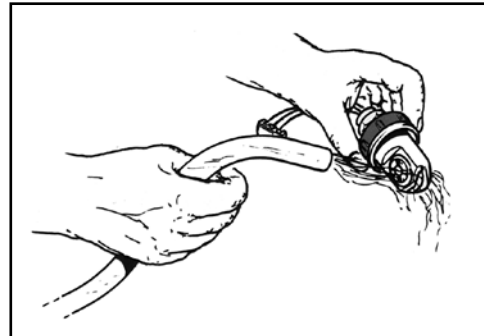

Wash any impurities out of the removable turbine unit.

- 3 Use clean water to wash any impurities out of the removable turbine unit.
- 4 Use compressed air to verify that the turbine unit rotates freely (maximum air pressure 1 BAR [15 psi]).

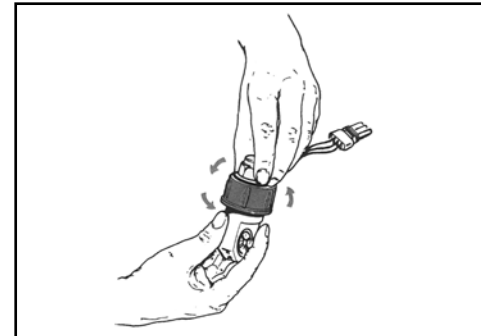

Unscrew the sensor.

Every 50 Hours

Carry out the following procedure after every 50 hours of operation:

- 1 Unscrew the sensor.
- 2 Separate the sensor from the Rapid Check unit.

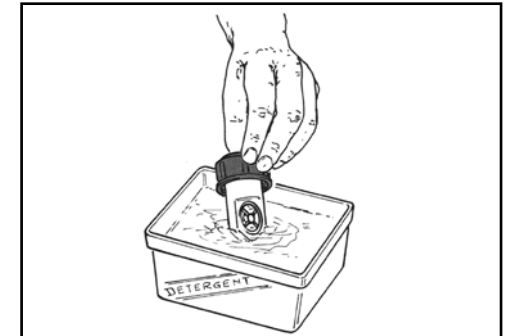

Place the Rapid Check unit in a detergent bath.

- 3 Place the Rapid Check unit in a detergent bath for a few hours.
- 4 Remove the Rapid Check unit from detergent bath.

Use compressed air to verify that the turbine unit rotates freely (maximum air pressure 1 BAR [15 psi]).

If necessary, replace the Rapid Check unit with a new one.

Remove the Rapid Check unit.

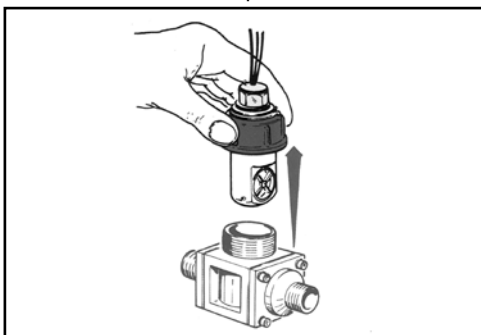

Use compressed air to check that the turbine unit rotates freely.

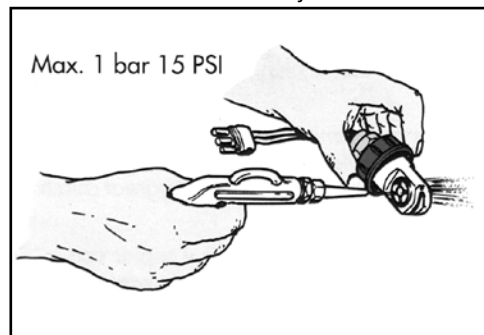

Separate the sensor from the Rapid Check unit.

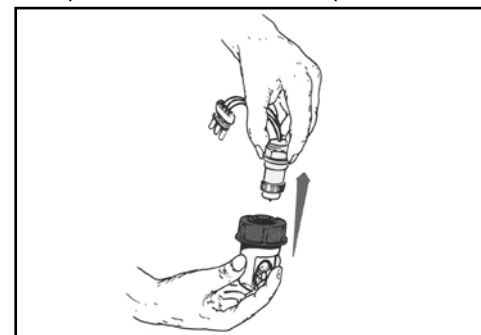

Use compressed air to check that the turbine unit rotates freely.

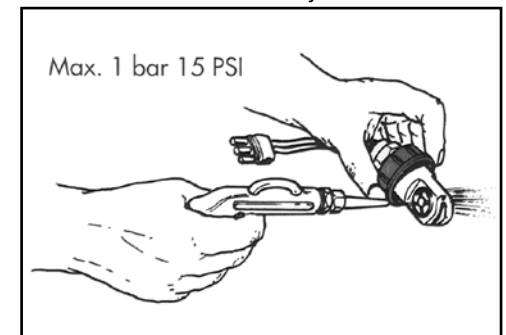

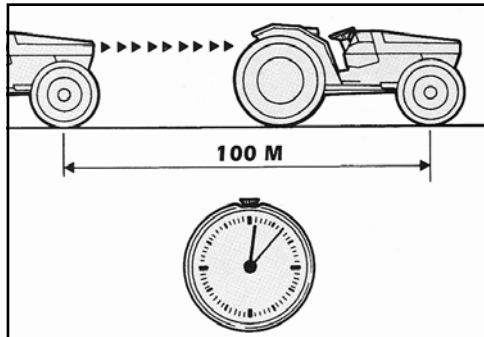

Determine actual speed of travel.



Determine spraying volume required.



Buyers Guide - courtesy of Teejet.



Fan head nozzles can be turned On or Off.

Step 2 Determine Actual Speed of Travel

It is essential to use actual speed of travel when calibrating application rates.

- Half fill the sprayer tank with water and mark out a test strip of 100 metres (simulating spraying conditions).
- Set the sprayer operating and record the time taken to travel 100 metres at your required spraying speed.
- Calculate the actual speed of travel using the formula:

$$\text{km/hr} = \frac{\text{Distance (m)} \times 3.6}{\text{Time (sec)}}$$

$$\text{Distance (m)} \times 3.6 \div \text{Time (sec)}$$

eg. $100 \times 3.6 \div 100$

$$= 3.6 \text{ km/hr}$$

An alternative formula is:

$$\text{km/hr} = \frac{\text{Metres travelled in 1 minute}}{60}$$

$$\text{Metres travelled in 1 minute}$$

Step 3 Determine Spraying Volume Required

It is essential to determine the **liquid volume per hectare** required to effectively spray a crop without overspraying or underspraying.

The term “litres per hectare” must be related to foliage and not just to land area.

The amount of liquid needed to effectively spray any given crop will vary greatly with:

- The type of crop,
- Row spacing,
- Width of canopy,
- Height of canopy.
- Stage of growth,
- Density of foliage,
- Type of leaf surface,
- Type of fruit (single or bunched)
- Type of sprayer used.

Step 4 Determine Sprayer Configuration

Once the volume of required spray volume per hectare is established, the next step in calibrating your sprayer is to determine:

- The **number of row(s)** to be sprayed in one pass, and
- The **total number of nozzles** to be used on the sprayer.

Both these factors can vary with the type of sprayer used and other factors mentioned under step 3 (on this page).

Example 1

A Quantum Mist to spray apples – using six spray heads, each with 8 nozzles (total 48 nozzles) to spray one row per pass.

Example 2

A Quantum Mist to spray Citrus – using eight spray heads, each with 8 nozzles (total 64 nozzles) to spray one row per pass.

NOTE

Always use Actual Speed of Travel for speed in the calibration formula.

NOTE

Use your own experience or a registered rate calibration consultant to determine effective application rates in litres per hectare.



Select and fit nozzles to the spray heads.



Individual spray heads can be turned ON or OFF.



Measure how much water is required to refill the tank.

Step 5 Determine & Select Nozzles

Knowing actual travel speed, application rate required, number of rows to be sprayed in one pass and total number of nozzles to be used, we can determine the nozzles required for the sprayer. Use the formula below:

$$\frac{\text{Litres/Minute/Nozzle}}{=} \frac{\text{Litres/Ha} \times \text{Km/hr} \div 600 \div \text{Total Number of Nozzles Used} \times \text{Row Spacing (m)} \times \text{Number of Rows in One Pass}}$$

Example 1

$500 \text{ (l/ha)} \times 3.9 \text{ km/hr} \div 600 \div 48 \text{ (nozzles)} \times 3\text{m (row spacing)} = 0.203 \text{ litres/minute/nozzle}$

$800 \text{ (l/ha)} \times 3.9 \text{ km/hr} \div 600 \div 64 \text{ (nozzles)} \times 3\text{m (row spacing)} = 0.244 \text{ litres/minute/nozzle}$

Once the the flow rate per nozzle is known, it is necessary to select an appropriate nozzle size from the relevant nozzle chart(s) (see page 4.8).

Example 2, Nozzle Selection

Using the TXB-VK Nozzle chart on page 4.8, the closest matches for 0.244 litres/minute/nozzle are:

- Yellow tip No. 3 giving 0.22 l/min, operating at 4 Bar (60 psi).

This nozzle with a marginal increase in pressure will meet our requirements.

Step 6 Fit & Test Selected Nozzles

Now, the most important calibration is to test for the **actual litres per hectare** achieved through your sprayer.

Use the following method to fit and test the selected nozzles:

- Fit selected nozzles to the sprayer.
- Fill your spray tank to overflowing & set the specified pump pressure and operate the sprayer for a short period to make sure all lines are full and nozzles are working properly (no blockages, leaks etc).
- Stop the sprayer and top up the tank with water to overflowing again.

- Operate the sprayer in the stationary position at the required pressure for approximately one minute.

- Measure how much water is required to refill the tank to the brim.

Now, divide the volume measured by the time taken (minutes).

$$\frac{\text{Output/min (l/min)}}{=} \frac{\text{Output (litres)} \div \text{Time (minutes)}}$$

Example 1

$$\frac{9.75 \text{ litres} \div 1.25 \text{ minutes}}{=} 7.8 \text{ litres/min.}$$

Example 2

$$\frac{19.5 \text{ litres} \div 1.25 \text{ minutes}}{=} 15.6 \text{ litres/min.}$$

CAUTION

Do not use worn nozzles to set the pressure setting and nozzle rates, otherwise inaccurate calibration will occur.

NOTE

The flow rate of each nozzle is dependent on the nozzle size and operating pressure.

NOTE

Remember when selecting nozzle outputs that higher pressures and wider spray angles usually give finer droplet sizes than lower pressures and narrower spray angles.

WARNING

Do not use mixed pesticides for testing. Use only clean water. Use of pesticides when testing is hazardous to your health.



+/- keys (Optional Auto Rate Controller).

Step 7 Calculate the Actual Application Rate

Actual application rate is the objective of setting up and calibrating your sprayer.

To calculate actual application rate (litres per hectare), use the following formula:

$$\text{Application Rate (l/ha)} = \frac{\text{Total Sprayer Output (l/min)} \times 600 \div \text{Speed (Km/hr)} \div \text{Row Spacing (m)} \div \text{Number Rows in One Pass}}$$

Example 1

9.75 (l/min) x 600 ÷ 3.9 km/hr ÷ 3m (row spacing) = 500 litres/ha.

Example 2

15.6 (l/min) x 600 ÷ 3.9 km/hr ÷ 3m (row spacing) = 800 litres/ha.

Step 8 If the Tested Rate is Unsatisfactory

If your tested application rate does not meet your requirements, your options are:

a) In Auto mode - if application rate is not being achieved:

- i) Operating pressure will climb if nozzles are too small or blocked or speed is too slow.

Likewise, if your pressure filter is blocked (even partially), you may experience excessive pressure at the pump.

Make adjustments accordingly.

- ii) Operating pressure will fall if nozzles are too large or speed is too slow. Make adjustments accordingly.

b) In Manual mode - the Controller application rate can be altered by:

- i) Adjusting pressure up or down to increase or decrease rate of application (use +/- keys).
- ii) Adjusting spraying speed up or down to decrease or increase rate of application.
- iii) Changing to a different nozzle capacity.

Repeat necessary testing procedures and calculation of application rate if adjustments or changes are made.

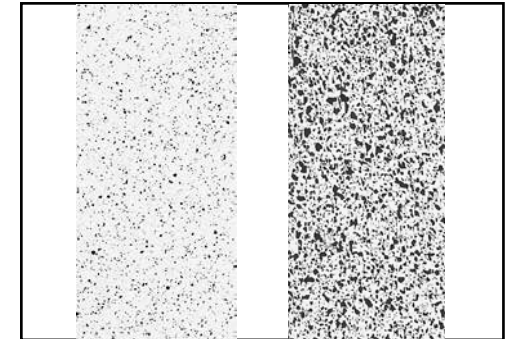

Samples of water sensitive paper tests.

Step 9 Field Check Coverage

Operate your sprayer in the required orchard or vineyard to check the actual spray coverage achieved on foliage.

This is important because it is the only real measure you have of actual coverage and effective penetration of your sprayer.

Coverage checks can be done using:

- A fluorescent dye system - often available through chemical and spray equipment suppliers.
- Water or oil sensitive papers available through chemical and spray equipment suppliers.
Ensure cards are strategically placed on both upper and lower surfaces.

It is recommended to test the unit using water only as a test run, and again when applying your chemical mixture.



CAUTION

Do not use worn nozzles to set the pressure setting and nozzle rates, otherwise inaccurate calibration will occur.

NOTE

The flow rate of each nozzle is dependent on the nozzle size and operating pressure.

Step 10 Add The Correct Amount Of Chemical To The Tank

a) For land area rates (litres or kg per hectare), use the following formula:

Chemical Required (litres) =

Tank Volume (litres) x Recommended
Chemical Rate (l/ha) ÷ Spray Application
Rate (l/ha)

eg, $[2000 \times 2.0] \div 50$
= 80 litres

b) If chemical recommendation is given in water volume rates use the following formula:

Chemical Required (litres) =

Tank Volume (litres) x Recommended
Chemical Rate (l/100 litres) ÷ 100

eg, $[2000 \times 4] \div 100$
= 80 litres

c) For tank volume required, use the formula:

Tank Volume Required (litres) =

Area (ha) x Spray Application Rate (l/ha)

eg, 20×50
= 1000 litres

Step 11 Adjust Fans

Fan angle and height can drastically affect spray coverage.

Contact your dealer for advice and information on optimum setup.

(Adjustment steps are shown on Page 3.6)

Step 12 Record All Data For Future Reference

Record all your calibration data on the work sheets given at the end of this section.

Photocopy the work sheets to obtain the number of work sheets required.

NOTE

Mix only the amount required. Avoid wastage and the problem of needless chemical disposal.

NOTE

All nozzles have a pressure and flow rate range to achieve the best results. Ensure you have selected the nozzle which best suits your application to avoid any problems.

NOTE

Full instructions of controller operation are contained in your separate Controller Manual.



Features:

- Angle of 80° at 5 bar
- Easy dismantling for cleaning
- Hollow cone nozzle producing fin droplets
- Albus durable pink ceramic allows precision high pressure spraying
- Polished ceramics ensure perfect sealing and precise flow rate.

Applications:

- For fungicides and insecticides
- Recommended for orchards and vineyards.

ALBUZ NOZZLE	PART NUMBER	MESH	5 Bar	6 Bar	7 Bar	8 Bar	9 Bar	10 Bar	11 Bar	12 Bar
WHITE	AZ-ATR-WE-80C	100	0.27	0.29	0.32	0.34	0.36	0.38	0.39	0.41
LILAC	AZ-ATR-LC-80C	50	0.36	0.39	0.42	0.45	0.48	0.50	0.52	0.55
CURRENT STANDARD	BROWN	AZ-ATR-BN-80C	50	0.48	0.52	0.56	0.60	0.64	0.67	0.70
CURRENT STANDARD	YELLOW	AZ-ATR-YW-80C	50	0.73	0.80	0.86	0.92	0.97	1.03	1.07
	ORANGE	AZ-ATR-OE-80C	50	0.99	1.08	1.17	1.24	1.32	1.39	1.45
	RED	AZ-ATR-RD-80C	50	1.38	1.51	1.62	1.73	1.83	1.92	2.01
	GREY	AZ-ATR-GY-80C	50	1.50	1.63	1.76	1.87	1.98	2.08	2.17
	GREEN	AZ-ATR-GN-80C	50	1.78	1.94	2.09	2.22	2.35	2.47	2.58
	BLACK	AZ-ATR-BK-80C	50	2.00	2.18	2.35	2.50	2.64	2.78	2.90
	BLUE	AZ-ATR-BE-80C	50	2.45	2.67	2.87	3.06	3.24	3.40	3.56

COMPARITIVE COMMENT	ALBUZ NOZZLE	TXB NOZZLE	MESH	5 Bar	6 Bar	7 Bar	8 Bar	9 Bar	10 Bar	11 Bar	12 Bar
Slightly Lower Output	WHITE	TXB800050VK	100	0.25	0.27	0.28	0.30	0.32	0.33	0.35	0.36
Slightly Lower Output	LILAC	TXB800067VK	50	0.33	0.36	0.39	0.41	0.43	0.45	0.47	0.49
Slightly Higher Output	BROWN	TXB8001VK	50	0.50	0.54	0.58	0.62	0.65	0.68	0.71	0.74
Slightly Lower Output	YELLOW	TXB80015VK	50	0.75	0.82	0.89	0.94	1.00	1.05	1.10	1.15
Slightly Higher Output	ORANGE	TXB8002VK	50	1.01	1.10	1.18	1.26	1.33	1.40	1.47	1.53
Substantially Lower Output	RED	TXB8003VK	50	1.53	1.67	1.80	1.93	2.04	2.15	2.25	2.35
Slightly Lower Output	GREY	TXB8003VK	50	1.53	1.67	1.80	1.93	2.04	2.15	2.25	2.35
Substantially Higher Output	GREEN	TXB8003VK	50	1.53	1.67	1.80	1.93	2.04	2.15	2.25	2.35
Slightly Higher Output	BLACK	TXB8004VK	50	2.03	2.23	2.40	2.57	2.72	2.87	3.01	3.14
Substantially Higher Output	BLUE	TXB8004VK	50	2.03	2.23	2.40	2.57	2.72	2.87	3.01	3.14

Step 1 Check the Sprayer is in Good Working Order

Step 2 Determine Actual Speed of Travel

Measure and mark a straight path of 100 metres (or more) of travelling conditions similar to the orchard or vineyard you are going to spray.

Half fill the spray tank & record the time (in seconds) to travel the measured distance.

Make sure that the tractor is travelling at spraying speed when you pass the start and finish marks and ensure the the fan and pump are at operational speed.

If you have a hectare metre or automatic controller you need to check the speed calibration of the contoller.

Tractor model	
Gear	
Range	
Dual power	
Engine RPM	
Speed in Km/hr	

Kilometres per Hour
= **Distance traveled (m) x 3.6**

Step 3 Determine Spraying Volume Required

It is essential to determine the liquid volume per hectare required to effectively spray a crop without overspraying or underspraying.

Use your own experience or a registered rate calibration consultant to determine effective volume in litres per hectare.

..... litres/ha

Step 4 Determine Sprayer Configuration

- **Number of row(s)** to be sprayed in one pass
- **Total number of nozzles** to be used

Step 5 Determine & Select Nozzles

Determine nozzle flow rate required:

Litres/Minute/Nozzle
=
Litres/Ha x Km/hr ÷ 600 ÷ Total Number of Nozzles Used x Row Spacing (m) x Number of Rows in One Pass

eg.
..... x ÷ 600 ÷ x x
= litres/minute/nozzle.

Once the flow rate per nozzle is known, select an appropriate nozzle size from the nozzle charts [see pages 4.9 -4.11].

Nozzle Selection:

Step 6 Fit & Test Selected Nozzles

The most important calibration is to test for actual litres per hectare.

Fill your spray tank to overflowing and run the sprayer for one minute, at the above operating settings, and record the total litres per minute used.

Output/min (l/min)
=
Output (litres) ÷ Time (minutes)
..... ÷
= litres/min.

Step 7 Calculate the Actual Application Rate

To calculate actual application rate (litres per hectare), use the following formula:

Application Rate (l/ha)
=
Total Sprayer Output (l/min) x 600 ÷ Speed (Km/hr) ÷ Row Spacing (m) ÷ Number Rows in One Pass

..... x 600 ÷ ÷ ÷
= litres/ha.

Record your data:

Farm location	
Crop to be sprayed	
Canopy width (m)	
Canopy Height (m)	
Spray Volume litres/ha	
No. Rows in one pass	
No. of nozzles used	
Litres/minute/nozzle	
Nozzle pressure	
Nozzle type	
Nozzle size & colour	
Tested Output in l/min	
Actual Litres/Hectare	

Note: If your sprayer has a flow meter fitted, you should calibrate it regularly. The calibration setting on the tag is a factory setting only and needs to be regularly checked - taking into consideration changes in density and/or viscosity of the product to be sprayed.

Step 1 Check the Sprayer is in Good Working Order

Step 2 Determine Actual Speed of Travel

Measure and mark a straight path of 100 metres (or more) of travelling conditions similar to the orchard or vineyard you are going to spray.

Half fill the spray tank & record the time (in seconds) to travel the measured distance.

Make sure that the tractor is travelling at spraying speed when you pass the start and finish marks and ensure the the fan and pump are at operational speed.

If you have a hectare metre or automatic controller you need to check the speed calibration of the contoller.

Tractor model	
Gear	
Range	
Dual power	
Engine RPM	
Speed in Km/hr	

Kilometres per Hour
=
Distance traveled (m) x 3.6

Step 3 Determine Spraying Volume Required

It is essential to determine the liquid volume per hectare required to effectively spray a crop without overspraying or underspraying.

Use your own experience or a registered rate calibration consultant to determine effective volume in litres per hectare.

..... litres/ha

Step 4 Determine Sprayer Configuration

- **Number of row(s)** to be sprayed in one pass
- **Total number of nozzles** to be used

Step 5 Determine & Select Nozzles

Determine nozzle flow rate required:

Litres/Minute/Nozzle
=
Litres/Ha x Km/hr ÷ 600 ÷ Total Number of Nozzles Used x Row Spacing (m) x Number of Rows in One Pass

eg.
..... x ÷ 600 ÷ x x
= litres/minute/nozzle.

Once the flow rate per nozzle is known, select an appropriate nozzle size from the nozzle charts [see pages 4.9 -4.11].

Nozzle Selection:

Step 6 Fit & Test Selected Nozzles

The most important calibration is to test for actual litres per hectare.

Fill your spray tank to overflowing and run the sprayer for one minute, at the above operating settings, and record the total litres per minute used.

Output/min (l/min)
=
Output (litres) ÷ Time (minutes)
..... ÷
= litres/min.

Step 7 Calculate the Actual Application Rate

To calculate actual application rate (litres per hectare), use the following formula:

Application Rate (l/ha)
=
Total Sprayer Output (l/min) x 600 ÷ Speed (Km/hr) ÷ Row Spacing (m) ÷ Number Rows in One Pass

..... x 600 ÷ ÷ ÷
= litres/ha.

Record your data:

Farm location	
Crop to be sprayed	
Canopy width (m)	
Canopy Height (m)	
Spray Volume litres/ha	
No. Rows in one pass	
No. of nozzles used	
Litres/minute/nozzle	
Nozzle pressure	
Nozzle type	
Nozzle size & colour	
Tested Output in l/min	
Actual Litres/Hectare	

Note: If your sprayer has a flow meter fitted, you should calibrate it regularly. The calibration setting on the tag is a factory setting only and needs to be regularly checked - taking into consideration changes in density and/or viscosity of the product to be sprayed.

Step 1 Check the Sprayer is in Good Working Order

Step 2 Determine Actual Speed of Travel

Measure and mark a straight path of 100 metres (or more) of travelling conditions similar to the orchard or vineyard you are going to spray.

Half fill the spray tank & record the time (in seconds) to travel the measured distance.

Make sure that the tractor is travelling at spraying speed when you pass the start and finish marks and ensure the the fan and pump are at operational speed.

If you have a hectare metre or automatic controller you need to check the speed calibration of the contoller.

Tractor model	
Gear	
Range	
Dual power	
Engine RPM	
Speed in Km/hr	

Kilometres per Hour
= **Distance traveled (m) x 3.6**

Step 3 Determine Spraying Volume Required

It is essential to determine the liquid volume per hectare required to effectively spray a crop without overspraying or underspraying.

Use your own experience or a registered rate calibration consultant to determine effective volume in litres per hectare.

..... litres/ha

Step 4 Determine Sprayer Configuration

- **Number of row(s)** to be sprayed in one pass
- **Total number of nozzles** to be used

Step 5 Determine & Select Nozzles

Determine nozzle flow rate required:

Litres/Minute/Nozzle
=
Litres/Ha x Km/hr ÷ 600 ÷ Total Number of Nozzles Used x Row Spacing (m) x Number of Rows in One Pass

eg.
..... x ÷ 600 ÷ x x
= litres/minute/nozzle.

Once the flow rate per nozzle is known, select an appropriate nozzle size from the nozzle charts [see pages 4.9 -4.11].

Nozzle Selection:

Step 6 Fit & Test Selected Nozzles

The most important calibration is to test for actual litres per hectare.

Fill your spray tank to overflowing and run the sprayer for one minute, at the above operating settings, and record the total litres per minute used.

Output/min (l/min)
=
Output (litres) ÷ Time (minutes)
..... ÷
= litres/min.

Step 7 Calculate the Actual Application Rate

To calculate actual application rate (litres per hectare), use the following formula:

Application Rate (l/ha)
=
Total Sprayer Output (l/min) x 600 ÷ Speed (Km/hr) ÷ Row Spacing (m) ÷ Number Rows in One Pass

..... x 600 ÷ ÷ ÷
= litres/ha.

Record your data:

Farm location	
Crop to be sprayed	
Canopy width (m)	
Canopy Height (m)	
Spray Volume litres/ha	
No. Rows in one pass	
No. of nozzles used	
Litres/minute/nozzle	
Nozzle pressure	
Nozzle type	
Nozzle size & colour	
Tested Output in l/min	
Actual Litres/Hectare	

Note: If your sprayer has a flow meter fitted, you should calibrate it regularly. The calibration setting on the tag is a factory setting only and needs to be regularly checked - taking into consideration changes in density and/or viscosity of the product to be sprayed.

Greasing & Service Procedures	5.2
Grease Points	5.3
Diaphragm Pumps	5.4
Filters	5.6
General Maintenance	5.7

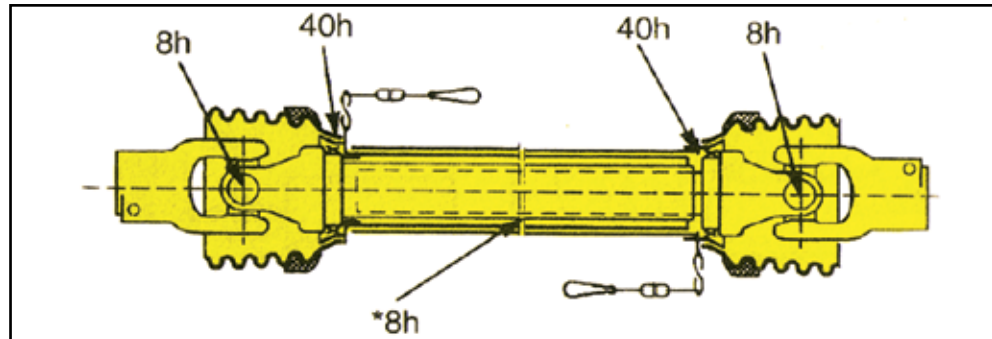

Grease the PTO shaft as shown. * Pull shaft apart - apply grease to the inside of the outer telescopic profile.

Greasing & Service Procedures

- 1 Clean suction line filter with each tank load.
- 2 Clean pressure line filter.
- 3 Check nozzle filters.
- 4 Check tyre pressure (350kPa), and check wheel nuts.
- 5 Clean Rapid-check flowmeter (refer to page 4.3), if fitted.

- 6 Grease tractor to sprayer PTO universal joints every 8 hours.
Grease lightly until grease becomes firm in seals. Over greasing will break seals and allow dust and moisture to penetrate - increasing wear.
- 7 Grease PTO inner tubes every 8 hours.
To lubricate the inner tube, slide PTO shaft apart, clean the telescopic tubes, grease and reassemble.
- 8 Grease the PTO covers every 20 hours.

- 9 Check pump air chamber pressure on a regular basis. As a general guideline it should be 10%-20% of operating pressure (70-100 kPa [10-15 psi]). Refer to page 2.16 for more information.
- 10 To ensure trouble free spraying, flush the sprayer with fresh water thoroughly each day, and before changing chemicals.
Dispose of tank wash according to chemical manufacturers instructions.
- 11 Grease all boom joints, height adjuster points and other grease points (refer diagram on page 5.3).



Remove & soak nozzles in Farm Mate cleaner.

Every 200 Hours

- 1 Lubricate quick release lock pins on PTO shaft.
- 2 Re-pack wheel bearings with grease.
- 3 Grease all tank lid seals with vaseline.
- 4 Check to ensure agitators have not become blocked with sulphur/chemicals.
- 5 Inspect all hydraulic lines for wear points.
- 6 Check pump mounts.
- 7 Check fan RPM and oil pressure at test port.
- 8 Soak all nozzles in FARM MATE cleaner, and thoroughly flush/clean sprayer with tank cleaner.

NOTE

Ensure the sliding inner tubes of the PTO are greased every 8 hours (working around the clock equals 3 times/day), especially when doing a lot of tight turning.



Grease all swivel drawbar grease points.

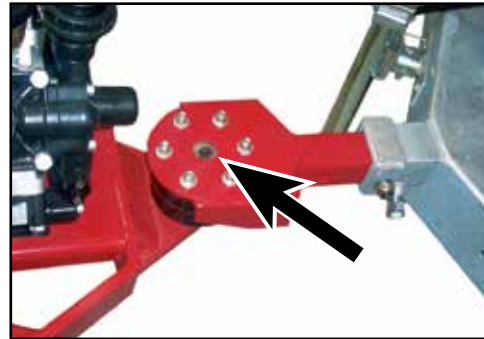

Grease the optional self-tracking drawbar.



Grease wheel hubs.



Grease the PTO shaft.

Grease Points

1 Swivel eye on drawbar - see page 2.10.

2 Optional self-tracking drawbar.

3 Wheel hubs, if fitted with grease nipples.

4 PTO shaft - all crosses (knuckles), both ends and sliding tubes. Refer to page 5.2 for frequency.

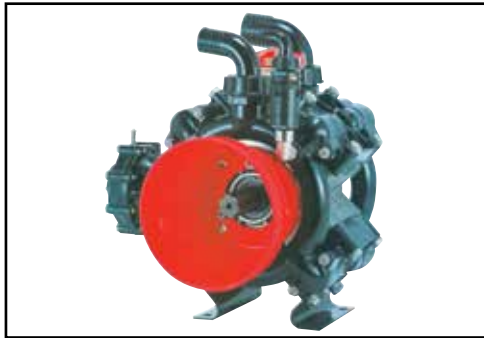

AR185 - 180l/min diaphragm pump.

Diaphragm Pump Maintenance

Annovi & Reverberi (A&R) pumps are of the piston-diaphragm type. All parts in contact with the spray liquid, which are subject to corrosion, are protected, making them ideal for spraying.

Daily Before Starting the Pump

- 1 Check that oil is visible in sight glass (half way up) and top up if necessary with good clean motor oil 20W/30 or 20W/40.
- 2 Clean all sprayer filters. Blocked or semi blocked filters place extra stress on diaphragms.
- 3 Start with zero pressure and the pump will self prime immediately and clear air locks in suction line.

Daily after Use

- 1 Flush pump with clean water.
- 2 Drain filters and clean. A high percentage of pump failures are due to blocked filters.

Every 50 Hours

Check surge chamber pressure and adjust as follows:

- Air pressure 70-100kPa (10- 15psi) [Should be 10-20% of operating pressure].

Vibration of the delivery hose usually indicates that the air pressure in the surge chamber is incorrect.

The main cause of surge chamber diaphragm fracture is low pressure in this chamber.

Surge chamber pressure can be checked with an ordinary tyre gauge.

The above pressure range is a guide to the correct pressure.

However, if difficulties recur, adjust the pressure until an even flow is obtained from the pump (no pulsing of liquid at operating RPM). The pressure is best increased with a bicycle pump, hand pump or foot pump.

Every 250 hours or Every Season - Whichever Comes Sooner

- 1 Change oil and refill with 20W/30 oil.

Attention should be made to remove trapped air behind the diaphragms by rocking from side to side as instructed.

It is also good practise to run the pump for 10 minutes without pressure, and then, top up with oil before working the pump.

- 2 When changing the pump oil, check diaphragms and replace them if they are showing signs of wear.

Diaphragm valves should be replaced every 400 hours regardless of wear.

This is normally a pre-season maintenance procedure which can be done easily as no special tools are required.

You can avoid unnecessary down time in spraying seasons by carrying out the proper maintenance.

- 3 Also check inlet and outlet valves and replace if worn. Worn valves not only reduce the output of the pump, but may reduce the life of the diaphragms.



CAUTION

Running a diaphragm pump faster than specified will not improve performance, but will damage and wear out moving parts.

Warranty will be made void by speeds in excess of those indicated on the pump name plate.

Excessive Diaphragm Failure

If you have excessive diaphragm failure check the following points. These will cause failure of diaphragms due to added stress or chemical attack.

- 1 **Most Important** - Pump not being flushed out daily with clean water after use.
- 2 Oil level too low allowing air between piston and diaphragm.
- 3 Air leaks in suction line.
- 4 Restricted suction line.
- 5 Restriction through suction filter.
- 6 Not cleaning suction filter regularly.
- 7 Worn suction and discharge valves.
- 8 Bypass line too small to carry full capacity of pump.
- 9 In cold climates - frozen suction/ discharge lines or water remaining in the pump after flushing.
- 10 Incorrect air setting or no air in air chamber.
- 11 Agitator excessively restricting bypass from pump.
- 12 Diaphragm material construction incorrect for chemical or solution being pumped.
- 13 Chemicals containing toluene or other aggressive solvents may require viton diaphragms - particularly if the pump is not properly flushed after use.

Pre-Season Servicing

For thorough pre-season servicing - check all aspects of the Quantum Mist and its operating components as outlined in the pre-delivery check list.

Pump Storage and Corrosion Protection

1 Warm Climates

If you operate in a warm climate with no chance of frost in the winter, you will not have any problems with frost damage.

If you are storing your sprayer between seasons, ensure your pump has been thoroughly flushed with clean water. A good idea is to run a mixture of 1% solution of summer mineral spraying oil through the pump and plumbing system. Summer spraying oil is water-soluble oil such as DC-Tron. This will coat and protect all internal pump parts. Ensure this mixture is flushed out before spraying commences in the new season.

2 Cold Climates

For prolonged storage, an anti-freeze mixture can be flushed through the pump. Ensure this is thoroughly flushed out prior to the commencement of spraying again. If the pump is being stored overnight and a risk of freezing is imminent, drain all liquid from the pump and lines, including boom lines.



The pump suction valve CLOSED to the main tank.



Remove the outer filter screw and bowl.



Reassemble and tighten the outer filter screw.



Open & close the filter tap while system is pressurised.

Filter Maintenance

Clean filters ensure that no solids enter the spraying system to block or damage pump or nozzles.

All filters should be cleaned regularly or after each spraying period.

Suction Filter

The suction filter should be cleaned regularly, or after each spray tank has been emptied.

To clean the filter:

- 1 Completely stop all sprayer functions.
- 2 Place the pump suction valve in the closed position to shut off liquid from the main tank.
- 3 Remove the outer filter screw and bowl.
- 4 Remove the filter screen & thoroughly clean it and other components before reassembling the filter.

Remove & clean the filter element & components.



- 5 Carefully reassemble the filter, ensuring the screen O-Rings are in place, and then, tighten the outer filter screw so that the outer O-ring is properly sealed.

- 6 Check the filter is sealed correctly by opening the pump suction valve to access liquid from the main tank.

If leaking, further tighten the outer screw until sealed. If this does not stop the leaking, check the alignment of the O-ring and/or the condition of the O-ring. Replace if necessary.

Vaseline is the best lubricant for filter seals.

In-line Pressure Filters

The in-line pressure filter should be cleaned regularly, or after each spray tank has been emptied.

To flush each filter, open and close the filter tap while system is pressurised.

The filter & bowl assembly will need to be disassembled for thorough cleaning.

NOTE

Be careful not to damage or deform the mesh or O-ring while cleaning and refitting the suction filter.

If the filter screen or O-ring is damaged, replace the part.

CAUTION

Ensure the **PUMP SUCTION VALVE IS OPEN** before starting the pump.

Starting the pump with the suction valve closed will seriously damage the suction valve and warranty will be made void.

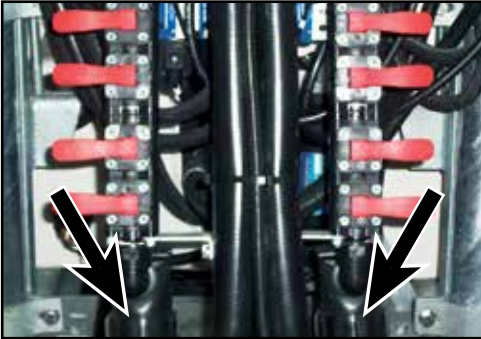

Clean both of the spray head tap filters regularly - before & after use.

In-line Filters Below the Spray Head Taps

The two filters located below the spray head taps should be cleaned regularly - before & after each use.



Regularly check and clean nozzle filters (if fitted).

Nozzle Filters

Nozzle filters should be cleaned regularly to avoid nozzle blockages.

To clean the nozzle filters:

- 1 Completely stop all sprayer functions.
- 2 Remove the nozzle cap and nozzle, and then remove the nozzle filter.
- 3 Thoroughly clean the nozzle filter.
Replace the filter if damaged.
- 4 If necessary, remove seal and nozzle from the cap to clean the nozzle.
- 5 Reassemble the nozzle components.
- 6 Check that nozzles are sealed correctly by testing with water under full operating pressure before spraying.

If leaking, check caps are correctly fitted with seals or the condition of the seals. Replace if necessary.



Remove & clean non-drip diaphragms regularly.

Non-Drip Diaphragms

Non-drip diaphragms should be cleaned regularly to prevent dripping from nozzles.

To clean the non-drip diaphragms:

- 1 Completely stop all sprayer functions.
- 2 Unscrew and remove the diaphragm cap.
- 3 Remove and clean any sediment off the diaphragm membrane.
Replace the diaphragm membrane if damaged.
- 4 Replace the diaphragm.
- 5 Refit the diaphragm cap and carefully tighten.

NOTE

Do not over tighten the diaphragm cap. Over tightening the cap may impede flow through the diaphragm.

<u>Diaphragm Pump Problems</u>	6.2
<u>General Sprayer Problems</u>	6.4

PROBLEM	PROBABLE CAUSE	REMEDY
A Pump does not draw or deliver liquid. Pressure gauge fluctuates badly.	<ol style="list-style-type: none"> 1 One or more valves are not seating properly. 2 The pump is sucking in air through suction line. 3 Air has not been entirely evacuated from the pump. 4 Blocked suction filter. 5 Damaged or worn suction valves. 	<ol style="list-style-type: none"> 1 Clean valve seating. 2 Examine the suction hose and ensure it is firmly secured. 3 Rotate the pump with outlet hose and taps open. 4 Clean suction filter. 5 Replace suction valves.
B Liquid flow is irregular (Also check items under A)	<ol style="list-style-type: none"> 1 The air in the air chamber of the pump is incorrectly set. 2 Diaphragm split. 3 Damaged or worn valves. 4 Foreign matter holding valves open. 	<ol style="list-style-type: none"> 1 Check pressure in air chamber of pump. Set at 210-280Kpa (30-40 psi). 2 Replace diaphragm. 3 Replace valves. 4 Clean valves.
C Pump delivers insufficient pressure	<ol style="list-style-type: none"> 1 Regulating valve: <ul style="list-style-type: none"> • Sticking open • Not set for pressure. • Damaged or worn seat or spring. 2 Cylinder diaphragm ruptured. 3 Pump valves blocked, worn or damaged. 4 Spray nozzles worn, missing or exceed pump capacity. 	<ol style="list-style-type: none"> 1 Fix the regulator: <ul style="list-style-type: none"> • Unstick the valves. • Set the pressure. • Replace the spring. 2 Replace diaphragms. 3 Unblock valves and or replace. 4 Replace spray nozzles with appropriate size.
D Output drops & pump is noisy.	<ol style="list-style-type: none"> 1 Oil level is too low. 	<ol style="list-style-type: none"> 1 Top up with oil to correct level (1/2 way up the sight glass).

PROBLEM	PROBABLE CAUSE	REMEDY
E Oil being discharged through delivery line or discoloured oil in sight glass of pump.	1 One or more diaphragms split or ruptured.	1 Immediately drain oil from pump and flush to remove all spray residues from sump. Remove pump heads & fit new diaphragms. Fill to correct level with motor oil 20W/30.
SUCTION SIDE OF PUMP		
F Suction hose vibration.	1 Air getting into suction.	1 Seal all joints securely with tape or stag. Firm up clamps. 2 Check the suction filter is sealed.
G Pump valves hammering.	1 Suction tap partly turned off. 2 Suction strainer(s) blocked.	1 Turn tap fully on. 2 Clean filters.
H No water flow in suction hose.	1 Obstruction in tank or suction line. 2 Suction tap in OFF position	1 Clean foreign material from tank & suction line. 2 Turn suction tap ON.
DISCHARGE SIDE OF PUMP		
I Pressure gauge pointer swings violently.	1 Pressure control valve spindle doesn't move easily.	1 Lubricate with light oil or C.R.C.
J AR control valve leaking from spindle.	1 Split diaphragm or O-rings.	1 Remove 4 body set screws, replace diaphragm and O-rings.
K Pressure gauge showing correct working pressure no pressure at nozzle.	1 Burst discharge line. 2 Blocked discharge filter where fitted. 3 O-ring(s) jamming flow in discharge line. 4 Ants, wasps build nests in discharge line or nozzles.	1 Replace discharge line. 2 Clean discharge filter. 3 Clean discharge line of foreign materials. 4 Clean nozzles of foreign materials with tooth brush

PROBLEM	PROBABLE CAUSE	REMEDY
1 No spray when turned on.	<ol style="list-style-type: none"> 1 Filter on the inlet side of the pump blocked. 2 Faulty pump. 3 Control valves not working. 	<ol style="list-style-type: none"> 1 Dismantle, clean & re-assemble. 2 Change pump. 3 Check all motor valves.
2 Sprays for short time only.	<ol style="list-style-type: none"> 1 Air inlet to tank blocked. 2 Filter on suction side of pump blocking or blocked. 	<ol style="list-style-type: none"> 1 Clean air vent. 2 Dismantle, clean & re-assemble the filter. If filter problem persists, clean out the tank & start again.
3 Spray is uneven around the spray-head.	<ol style="list-style-type: none"> 1 Some nozzle filters or tips are blocked. 2 Nozzle tips worn. 3 Different pressure at nozzles; wrong nozzles fitted. 	<ol style="list-style-type: none"> 1 Remove, clean & check. Check output & for streaks. 2 Check nozzle output, replace worn nozzles. 3 Remove a nozzle in each section & check that flow rate is the same. If different, check for blockages.
4 Pressure going up - output going down.	<ol style="list-style-type: none"> 1 Nozzle filters blocking. 2 Pressure filter blocking. 	<ol style="list-style-type: none"> 1 Dismantle, clean & refit. Check pressure returns to normal. Check all filters and spray mixture. 2 Check & clean the pressure filter.
5 Pressure falling.	<ol style="list-style-type: none"> 1 Filter on suction side blocked. 2 Nozzle tips worn. 3 Pressure gauge faulty. 4 Pump worn. 	<ol style="list-style-type: none"> 1 Dismantle & clean the filter. 2 Check nozzle output, replace worn nozzles. 3 Check with new pressure gauge. 4 Repair or replace the pump.
6 Spray pattern narrow or faltering.	<ol style="list-style-type: none"> 1 Pressure too low. 2 Nozzles blocked or partially blocked. 	<ol style="list-style-type: none"> 1 Check that the correct nozzles are being used. 2 Check that the tank is not empty. If not, there is an air leak between the pump & tank or in the pump. Check plumbing & repair. 3 Check nozzles & clean as required.
7 Foam in the tank.	<ol style="list-style-type: none"> 1 Too much agitation. 	<ol style="list-style-type: none"> 1 Switch Off one or both agitators.

Pumps	7.2
UCM/ECM Controllers (Pressure Relief Valve)	7.8
2000 Litre Models	7.10
3000 Litre Models	7.14
4000 Litre Ultra Models	7.16
Axle & Stub Axles	7.18
QM500 Spray Head Assembly	7.29
Liquid System Components	7.34
Electrical Diagrams	7.36
Plumbing Diagrams	7.38
Useful Formulae for Calibrating Sprayers	7.40
Notes	7.41

Pos	Part No	Description	Qty
1	AR580013	Pump body	1
2	AR580150	Manifold line	1
3	AR550101	Right head	2
4	AR550102	Left head	1
5	<i>AR180152</i>	<i>M 10 Nut</i>	3
8	<i>AR550080</i>	<i>Diaphragm - Gomma</i>	3
8	<i>AR550084</i>	<i>Diaphragm - Viton</i>	3
8	<i>AR550085</i>	<i>Diaphragm - Desmopan</i>	3
8	AR550086	Diaphragm - H.P.D.S.	3
9	AR580110	Sleeve - AR115 bp	3
9	<i>AR580350</i>	<i>Sleeve - AR135 bp</i>	3
10	AR500260	Piston ring	3
12	AR580120	Piston	3
13	AR380300	Pin	3
14	AR380080	Pin ring	6
15	AR580140	Connecting rod	3
16	AR320030	O-Ring ø 31.5 x 4.5	6
17	AR759051	Complete valve	6
18	AR540541	Ring nut 1" 3/4 G spec	1
19	AR390291	O-Ring ø 28.25 x 2.62	7
20	AR540530	Threaded adapter 1"1/4-1"3/4 G (M)	1
21	<i>AR390271</i>	<i>M8 Nut</i>	3
23	AR580050	Gasket	1
25	AR580180	Lower air chamber	1
26	AR550190	Semi air chamber - Gomma	1
26	<i>AR550191</i>	<i>Semi air chamber - Saturflon</i>	1
26	AR550192	Semi air chamber - Viton	1
26	<i>AR550193</i>	<i>Semi air chamber - H.P.D.S.</i>	1
27	AR550233	Upper air chamber Black	1
28	AR550300	Air-valve	1
29	AR650542	Gasket	1
30	AR550680	Bolt M8 x 20	4
31	AR200391	Circlip	1
32	AR550470	Gasket retainer	1
33	AR550070	Spacer ring	1
34	AR550060	Roller bushing	1
35	AR550170	"SP" shaft - AR115 bp (AL)	1
35	AR580380	"SP" shaft - AR135 bp (AT)	1
36	AR580470	Con rod ring	2
37	<i>AR551040</i>	<i>Bolt M10 x 55 Bolt</i>	8
38	AR550310	Roller bushing	1
46	AR550340	Nipples 1"G(M)-1"G(M) Threaded adapter	1
47	AR550350	O-Ring ø 23.81 x 2.62	1
48	AR550242	Ring nut 1" G	1
49	AR550370	Elbow ø 25	1
50	AR540550	Elbow ø 40	1
52	AR250310	O-Ring ø 36.14 x 2.62	1
53	AR550491	Seal ring	1
54	AR650920	O-Ring ø 53.65 x 2.62	1
55	AR880530	Plug 3/8" G	1
56	<i>AR330173</i>	<i>Plug 1/2" G</i>	1
57	AR580071	Right manifold coupling	1

Pos	Part No	Description	Qty
58	AR580072	Left manifold coupling	1
59	AR1500350	Cardan protection	1
60	<i>AR550332</i>	<i>Washer øi 6.5</i>	2
61	<i>AR320621</i>	<i>Washer øi 10.5</i>	5
62	AR740290	O-Ring ø 14 x 1.78	1
63	AR550173	"C" shaft - AR115 bp (AM)	1
63	<i>AR580330</i>	<i>"C" shaft - AR135 bp (AS)</i>	1
64	AR580370	Plate	3
65	AR580360	Diaphragm pin	3
66	AR250310	O-Ring ø 36.14 x 2.62	1
67	AR580080	Base	1
68	<i>AR540301</i>	<i>Bolt M10 x 30</i>	1
69	<i>AR200233</i>	<i>Washer øi 10.5</i>	2
70	AR580400	Right man. coup. + outlet	1
71	AR550460	Elbow ø 18	1
72	AR550450	3/4" G Ring nut	1
73	AR880831	O-Ring ø 15.54 x 2.62 - Viton	1
74	<i>AR1609000</i>	<i>Safety valve</i>	1
75	AR881560	Elbow 90° 1/2"G (M)-(F)	1
76	<i>AR580421</i>	<i>(M)-(F) 1/2"G Extension</i>	1
77	AR180101	O-Ring ø 17,5x2 O-Ring	1
78	<i>AR850851</i>	<i>M6 x 30 Bolt</i>	2
79	<i>AR620472</i>	<i>M10 x 20 Bolt</i>	3
80	AR550175	"CRxS" shaft - AR115 bp (AN)	1
80	<i>AR580430</i>	<i>"CRxS" shaft - AR135 bp (AX)</i>	1
81	AR390180	O-Ring ø 18.72 x 2.62	1
82	AR1040310	Oil tank	1
83	AR650920	O-Ring ø 53.65 x 2.62 O-Ring	1
84	AR1040322	Black oil tank cap - AR 115 bp	1
84	<i>AR1040320</i>	<i>Red oil tank cap - AR 135 bp</i>	1
85	AR580230	O-Ring ø 69.52 x 2.62	1
86	<i>AR550920</i>	<i>Flange</i>	1
87	<i>AR550950</i>	<i>M10 x 25 Bolt</i>	3
88	AR180030	M8 x 20 Bolt	1
89	AR620561	O-Ring ø 78 x 2.5	1
90	<i>AR621000</i>	<i>Gear cap</i>	1
91	<i>AR550930</i>	<i>Gear Z= 64</i>	1
92	AR620950	Gasket	1
93	<i>AR1140370</i>	<i>Oil plug & O-ring</i>	1
94	<i>AR1980740</i>	<i>Plug 3/8" G Brass</i>	3
95	AR740290	O-Ring ø 14 x 1.78	3
96	<i>AR621010</i>	<i>Bolt M10 x 75</i>	4
97	<i>AR620960</i>	<i>Gear box</i>	1
98	AR540290	Bolt M8 x 25	4
99	<i>AR651000</i>	<i>Bolt 5/16"x 24" UNF x 1"</i>	1
100	<i>AR881090</i>	<i>Key</i>	1
101	AR961800	Seal ring	1
102	<i>AR961790</i>	<i>Circlip</i>	1
103	<i>AR320240</i>	<i>Circlip</i>	2
104	AR961780	Bearing	1
105	<i>AR621660</i>	<i>Pinion</i>	1
106	<i>AR620990</i>	<i>Bearing</i>	1

NOTE

Parts in Italics are non-stocked items and may need to be ordered.

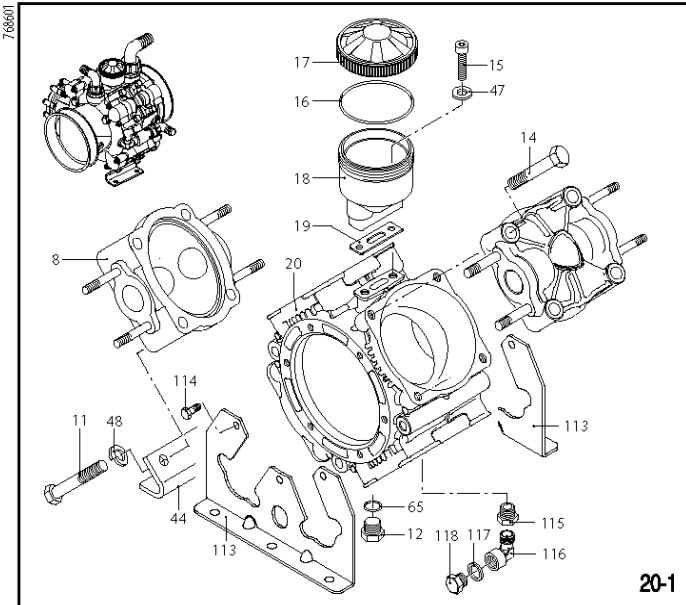

SL00209-AU

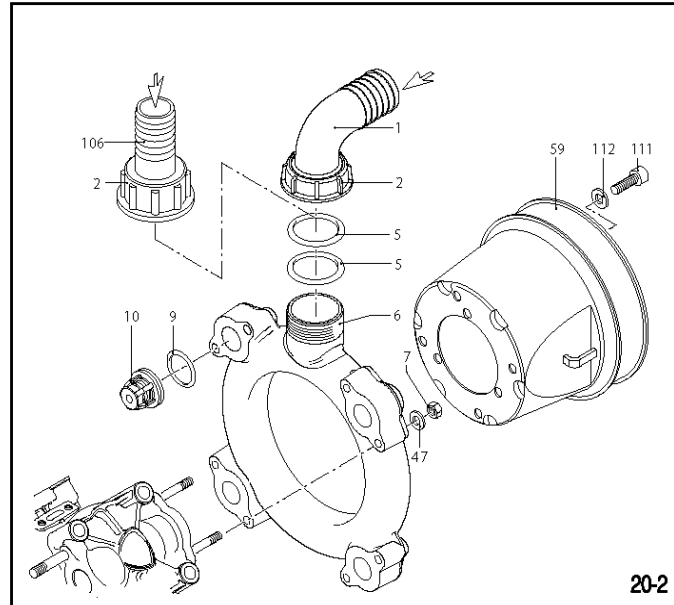

SL000155-DV

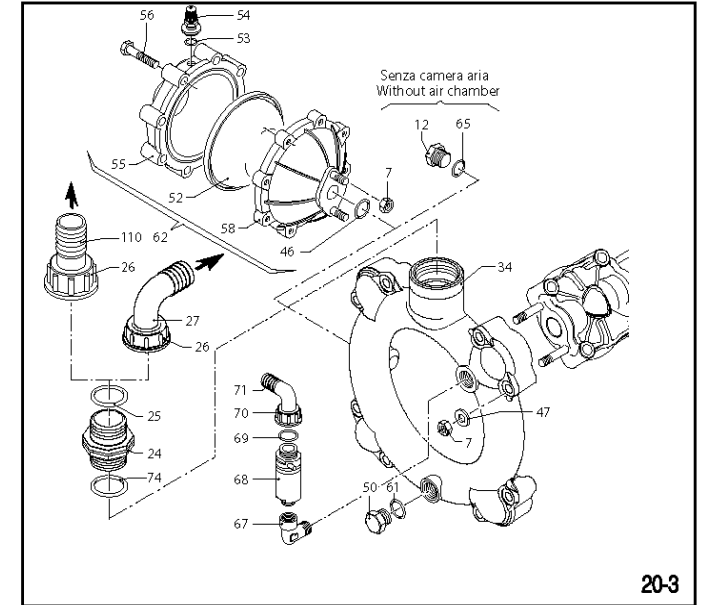

SL000156-DV

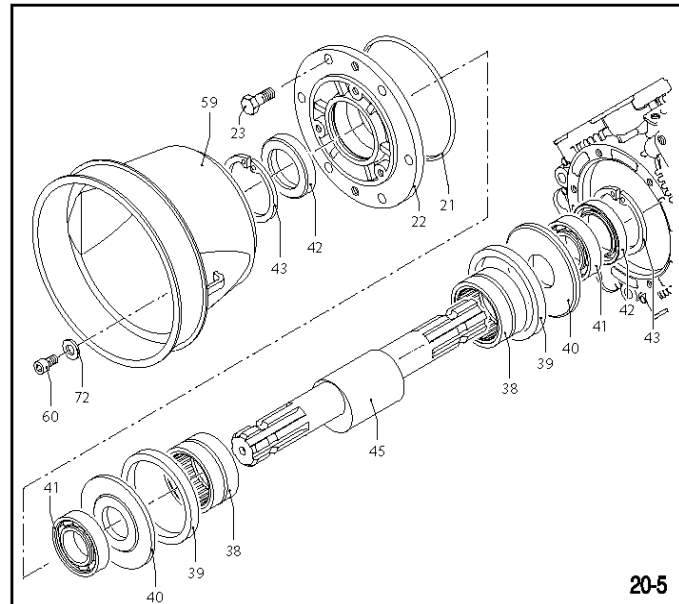

11MXXV71A ID

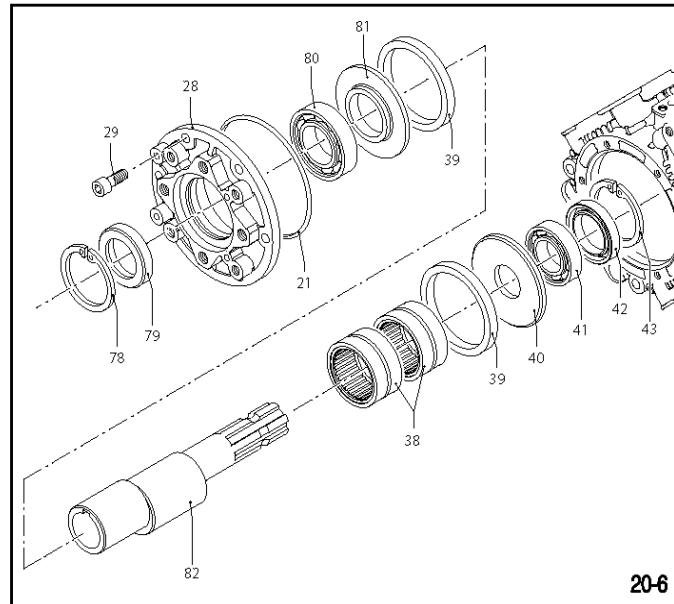

UN000715-IB

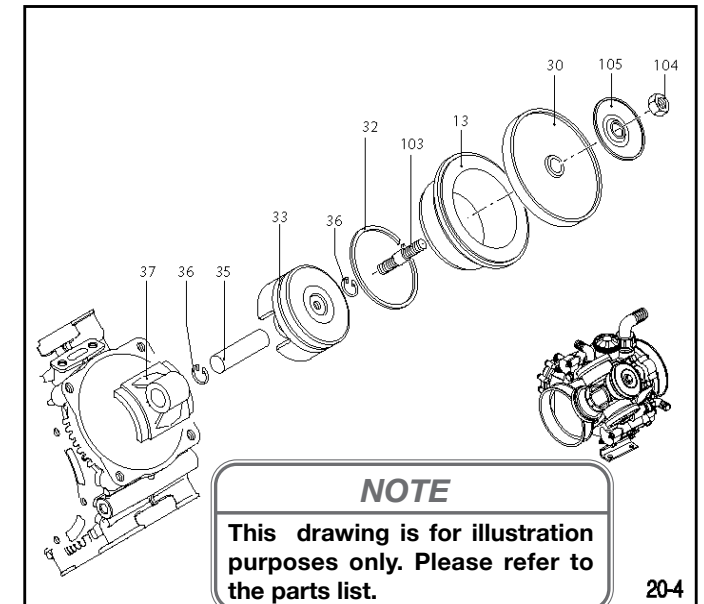

SL000208-AU

Pos	Part No	Description	Qty
1	AR3040430	Ø 40 Elbow - AR 160 bp	1
	AR3040440	Ø 50 Elbow - AR 185 bp	1
2	AR3040450	2" G Ring nut	1
5	AR3040470	OR Ø 39.3 x 2.6 O-ring	2
6	AR760750	Line	1
7	AR380242	M8 Nut - Geomet C 20	18
	AR380244	M8 Nut - Inox C 20	18
8	AR751350	Head	4
	AR751352	Head	4
9	AR680070	OR Ø 31.5 x 4.25 O-ring	8
10	AR759051	Valve	8
11	AR750071	TE M12 x 70 Screw - Geomet C 50	4
	AR750072	TE M12 x 70 Screw	4
12	AR880530	3/8" G Plug - C 20	2
	AR2340350	3/8" G Plug - Inox C 20	2
13	AR750110	Sleeve - AR 160 bp	4
	AR750115	Sleeve - AR 185 bp	4
14	AR750061	TE M12 x 65 Screw - Geomet C 50	12
	AR750062	TE M12 x 65 Screw - Inox C 50	12
15	AR680350	TCEI M8 x 35 Screw	2
16	AR1040060	Ø 72.69 x 2.62 O-ring	1
17	AR750057	Plug - AR 160 bp	1
	AR750052	Plug - AR 185 bp	1
18	AR750030	Tank	1
19	AR750040	Gasket	1
20	AR761010	Pump body	1
21	AR851360	Ø 120.32 x 2.62 O-ring	1
22	AR680020	Support	1
23	AR160672	TE M10 x 25 Screw - Geomet C 40	6
	AR160673	TE M10 x 25 Screw - Inox C 40	6
24	AR751130	1"1/2 G M-M Fitting	1
25	AR390290	Ø 29x3 O-ring	1
26	AR750670	1" 1/2 G Ring nut	1
27	AR760930	Ø 25 Elbow - AR 160 bp	1
	AR3040160	Ø 35 Elbow - AR 185 bp	1
28	AR2420181	Support	1
29	AR650640	TCEI M10 x 25 Screw - Geomet C 40	6
	AR650642	TCEI M10 x 25 Screw - Inox C 40	6
30	AR550080	Diaphragm - NBR	4
	AR550084	Diaphragm - Viton	4
	AR550085	Diaphragm - Desmopan	4
	AR550086	Diaphragm - HPDS	4
32	AR500260	Piston ring	4
33	AR750122	Ø 80 Piston	4
34	AR760760	Line	1
35	AR160700	Pin	4
36	AR160691	Øi 18 Ring	8
37	AR760140	Connecting-rod	4
38	AR750090	Bearing	2
39	AR750130	Ring	2
40	AR540040	Plate	2
41	AR230350	Bearing	2
42	AR160740	Ring	2
43	AR200390	Øi 62 Ring	2
44	AR760201	Foot	2
45	AR750170	C/C m-AU Shaft - AR 160 bp	1
	AR750174	C/C m-AV Shaft - AR 185 bp	1

NOTE

Parts in Italics are non-stocked items and may need to be ordered.

Pos	Part No	Description	Qty
46	AR390290	Ø 29x3 O-ring	1
47	AR380243	Washer - Geomet	18
	AR390315	Washer - Inox	18
48	AR250143	Washer - Geomet	4
	AR250144	Washer - Inox	4
50	AR330173	1/2" G Plug - Geomet C 20	1
	AR330174	1/2" G Plug - Inox C 20	1
52	AR550190	Semi air chamber - NBR	1
	AR550191	Semi air chamber - Saturflon	1
	AR550192	Semi air chamber - Viton	1
	AR550193	Semi air chamber - HPDS	1
53	AR650542	Gasket	1
54	AR180020	Air valve	1
55	AR620232	Semi air chamber	1
56	AR621781	TE M8 x 40 Screw	8
62	AR1782	TE M8 x 40 Screw	8
58	AR680180	Halfball	1
59	AR1500470	Cardan protection	2
60	AR850251	M8 x 12 Screw	3
	AR850252	TCEI M8 x 12 Screw	3
61	AR180101	Ø 17.5 x 2 O-ring	1
62	AR1552	Air chamber	1
65	AR740290	Ø 14 x 1.78 O-ring 2	
67	AR881560	1/2" G M-F Fitting 1	
68	AR1609000	Safety valve	1
69	AR880831	Ø 15.54 x 2.62 O-ring - Viton	1
70	AR550450	3/4" G Ring nut	1
71	AR550460	Ø 18 Elbow	1
72	AR390314	Washer - Geomet	3
	AR390315	Washer - Inox	3
74	AR751140	Ø 47.22 x 3.53 O-ring	1
78	AR620330	Øi 65 Ring	1
79	AR1800090	Ring	1
80	AR230310	Bearing	1
81	AR760510	Plate	1
82	AR760450	C/F Ø25 m-BX Shaft - AR 160 bp	1
	AR760520	C/F Ø32 m-BS Shaft - AR 160 bp	1
	AR760460	C/F Ø25 m-BZ Shaft - AR 185 bp	1
	AR760530	C/F Ø32 m-BT Shaft - AR 185 bp	1
103	AR2240100	Hub pin	4
104	AR2240110	M10 Nut	4
105	AR751250	Wobble plate	4
106	AR760950	Ø 40 Hose tail - AR 160 bp	1
	AR760570	Ø 50 Hose tail - AR 1854 bp	1
110	AR760920	Ø 25 Hose tail - AR 160 bp	1
	AR760940	Ø 35 Hose tail - AR 185 bp	1
111	AR820673	TCEI M10 x 16 Screw - Geomet	3
	AR820672	TCEI M10 x 16 Screw - Inox	3
112	AR320621	Washer 3 Geomet	
	AR320622	10.5 x 21x 2 Washer - Inox	3
113	AR761030	Foot	2
114	AR160672	TE M10 x 25 Screw - Geomet C 20	6
	AR160673	TE M10 x 25 Screw - Inox C 20	6
115	AR1040491	3/8" M-F Fitting	1
116	AR900210	3/8" G M-F Fitting	1
117	AR2260200	Washer	1
118	AR2281270	3/8" G Plug	1

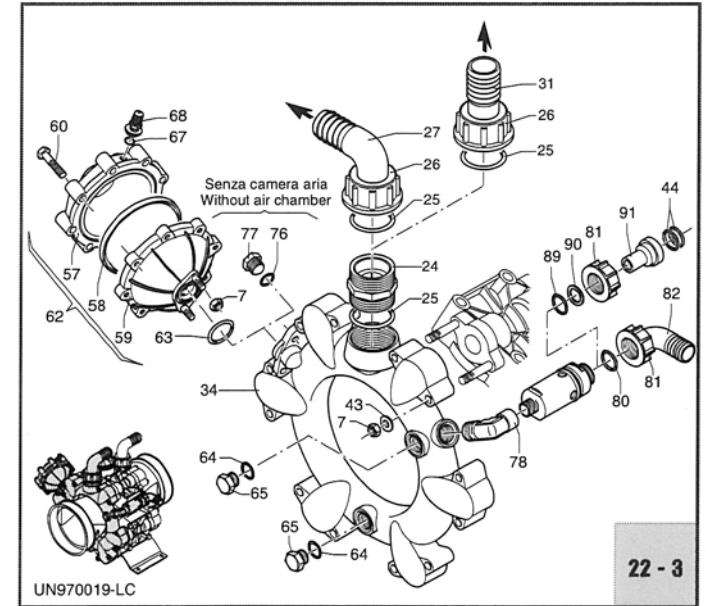
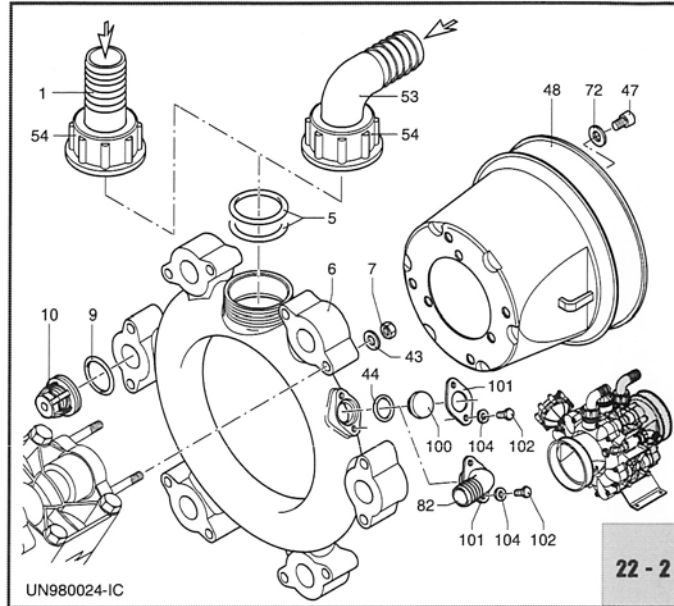
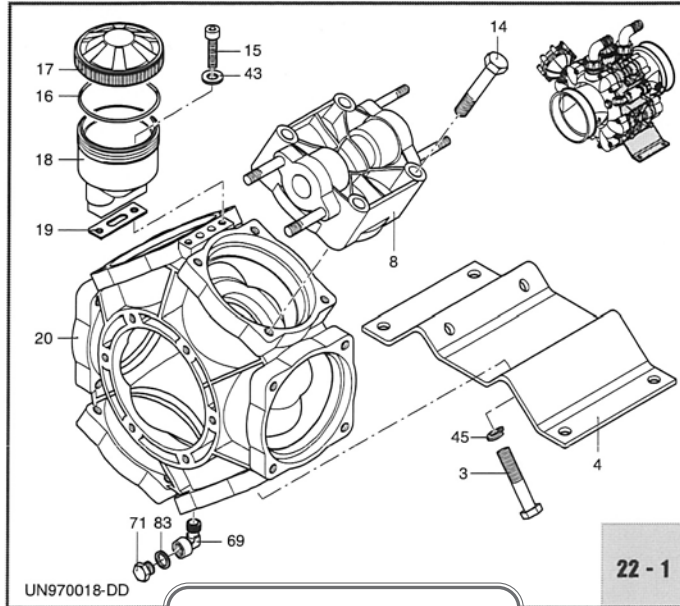

NOTE

These drawings are for illustration purposes only. Please refer to the parts list.

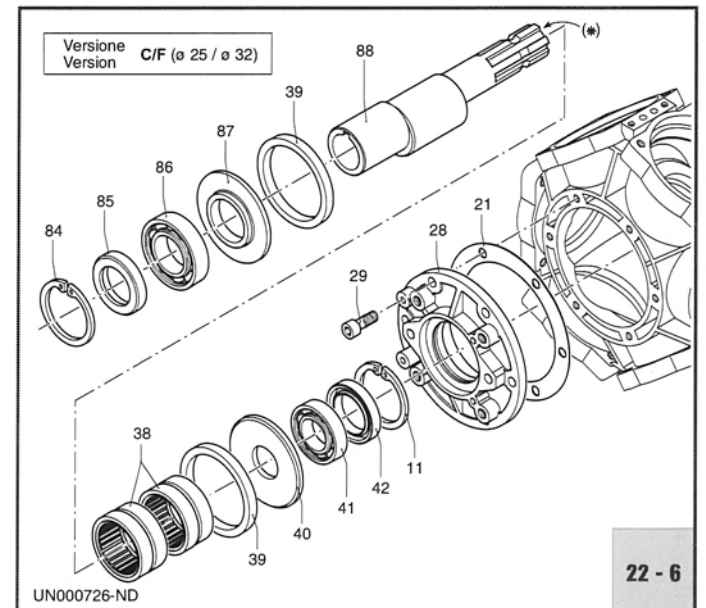
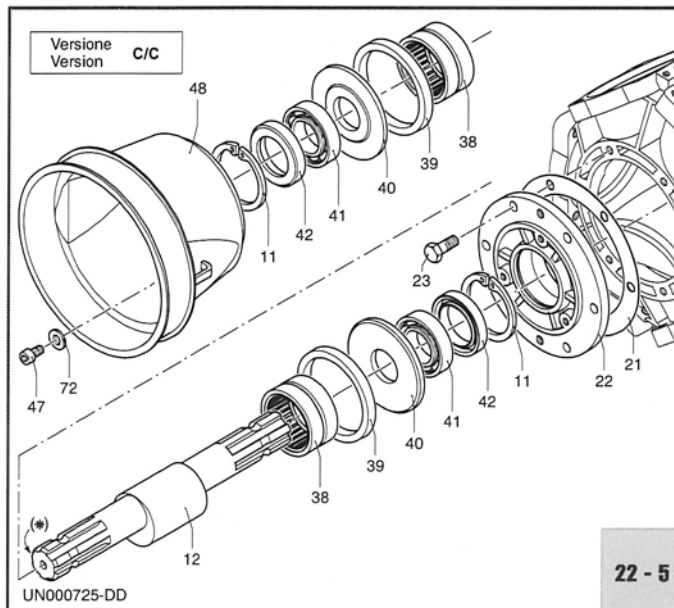
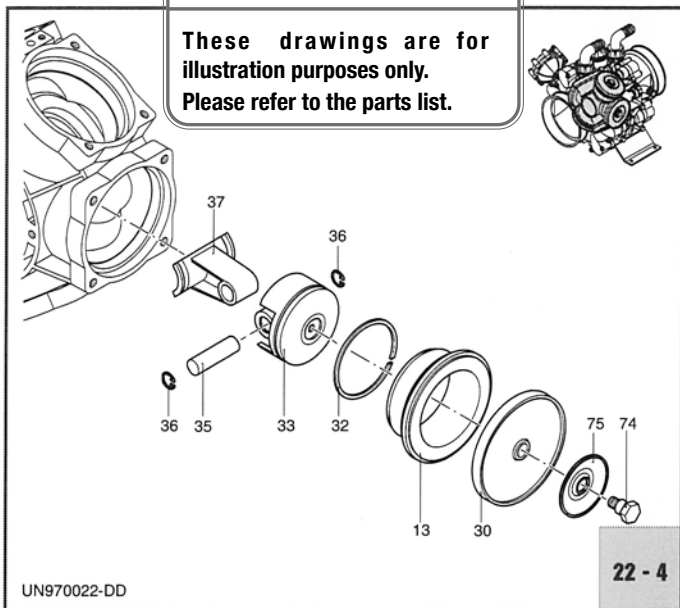

Pos	Part No	Description	Qty
1	AR750870	<i>ø 50 Hose tail</i>	1
	AR750730	<i>ø 60 Hose tail</i>	1
3	AR750071	<i>M12 x 70 Bolt</i>	4
4	AR750200	Base plate	1
5	AR750740	74 x 3.53 O-Ring	2
6	AR750860	Suction manifold	1
7	AR380242	<i>Nut</i>	26
8	AR750100	Head	6
9	AR680070	O-Ring	12
10	AR759051	Complete valve	12
11	AR200390	Circlip	2
12	AR750176	<i>Crankshaft AR 215 bp (AZ)</i>	1
	AR750170	<i>Crankshaft AR 250 bp (AU)</i>	1
	AR750174	<i>Crankshaft AR 280 bp (AV)</i>	1
13	AR750117	<i>Sleeve AR 215 bp</i>	6
	AR750110	<i>Sleeve AR 250 bp</i>	6
	AR750115	<i>Sleeve AR 280 bp</i>	6
14	AR750061	<i>M 12x65 Bolt</i>	20
15	AR680350	M8 x 35 Bolt	2
16	AR1040060	O-Ring	1
17	AR750053	<i>Green oil tank cap AR 215 bp</i>	1
	AR750057	<i>Black oil tank cap AR 250 bp</i>	1
	AR750052	<i>Red oil tank cap AR 280 bp</i>	1
18	AR750030	Oil tank	1
19	AR750040	Gasket	1
20	AR750010	Pump body	1
21	AR680250	Gasket	1
22	AR680020	<i>Shaft support</i>	1
23	AR160672	<i>M 10x25 Bolt</i>	6
24	AR540530	1"1/4-1"3/4 G (M) Threaded adapter	1
25	AR250310	O-Ring	2
26	AR540540	1"3/4 G Ring nut	1
27	AR392130	<i>ø 35 Elbow</i>	1
28	AR2420180	<i>Shaft support</i>	1
29	AR621500	<i>M10 x 25 Bolt</i>	6

Pos	Part No	Description	Qty
30	AR550084	<i>Diaphragm - VITON</i>	6
	AR550086	<i>Diaphragm - HPDS (Recommended)</i>	6
31	AR391930	<i>ø 35 Hose tail Optional</i>	1
32	AR500260	Piston ring	6
33	AR750122	Piston 80mm	6
34	AR750420	Manifold	1
35	AR160700	Pin	6
36	AR160691	Pin circlip	12
37	AR750140	<i>Connecting rod</i>	6
38	AR750090	Roller bearing	2
39	AR750130	Con rod ring	2
40	AR540040	<i>Spacer washer</i>	2
41	AR230350	Bearing	2
42	AR160740	Seal Ring 35 x 52 x 12mm	2
43	AR380243	<i>Washer</i>	26
44	AR480440	O-Ring	3
45	AR250143	<i>Washer</i>	4
47	AR850251	<i>M8 x 12 Bolt</i>	6
48	AR1500350	Shaft guard	2
53	AR750850	<i>ø 50 Elbow AR 215 bp</i>	1
	AR750850	<i>ø 50 Elbow AR 250 bp</i>	1
	AR750720	<i>ø 60 Elbow AR 280 bp</i>	1
54	AR750710	2"1/2 G Ring nut	1
57	AR620232	<i>Upper air chamber</i>	1
58	AR550190	Semi air chamber - RUBBER	1
	AR550192	<i>Semi air chamber - VITON</i>	1
	AR550193	<i>Semi air chamber - HPDS</i>	1
59	AR680180	Lower air chamber	1
60	AR621781	<i>M8 x 40 Bolt</i>	8
62	AR1552	Complete air chamber	1
63	AR390290	O-Ring	1
64	AR180101	O-Ring	2
65	AR330173	<i>1/2" G Plug</i>	2
67	AR650542	Gasket	1
68	AR180020	Air valve	1

NOTE

Parts in Italics are non-stocked items and may need to be ordered.

Section 7

UCM/ECM Controllers (Pressure Relief Valve)

Pos	Part No	Description	Qty
1	AR1547	Left 2-way valve	1
1	AR1548	Left 3-way valve	1
2	AR1571	Right 2-way valve	1
2	AR1572	Right 3-way valve	1
3	<i>AR1348</i>	<i>ECM compl.reg.valve</i>	<i>1</i>
3	AR1349	UCM compl.reg.valve	1
4	AR1351	Distributor body+R	1
5	AR1553	Complete filter	1
10	AR394850	2-way valve body	1
11	AR394860	3-way valve body	1
12	AR394690	Red valve lever	4
13	AR390330	Pin	5
14	AR390341	O-Ring	4
15	<i>AR390312</i>	<i>Washer</i>	<i>4</i>
16	AR390300	Spring	4
17	AR390313	Washer	4
18	AR390323	Complete valve rod	4
19	AR180101	O-Ring	5
20	AR392600	Threaded adapter	4
20	<i>AR392604</i>	<i>Plug - optional</i>	
21	AR640070	O-Ring	4
22	AR392580	Fork	4
23	AR392870	Hose tail	4
23	AR392590	Hose tail	4
23	AR392620	Hose tail	4
24	AR390291	O-Ring	5
30	AR480550	Circlip	1
31	AR394790	Adjustment knob	1
32	AR394770	Spring pin	1
33	AR1040830	Spring	1
34	AR390440	Nut	16
35	AR550331	Washer	12
36	AR394780	Upper body	1
37	AR394751	Piston	1
38	AR394741	Diaphragm - Gomma	1
38	<i>AR394741</i>	<i>Diaphragm - Desmopan (AR394740 obsolete)</i>	<i>1</i>
38	<i>AR394742</i>	<i>Diaphragm - Viton</i>	<i>1</i>
39	AR394720	Valve	1
40	AR394730	Spring	1
41	AR394830	Stud	8
42	AR680700	Bolt	1
43	AR394700	Regulating valve body	1
44	AR395530	Fork	5
45	AR394800	Pressure gauge attach	1
46	AR550450	Ring nut	1

Pos	Part No	Description	Qty
47	AR391240	Pressure gauge, 0-20 bar	1
48	AR660170	O-Ring	3
49	AR394810	Flange	1
50	AR550350	O-Ring	4
51	AR550242	Ring nut	2
52	AR550210	Hose tail	2
53	AR394840	Flange	1
54	AR550340	Threaded adapter	1
55	AR550370	Elbow	1
56	AR395000	Manifold nipples	2
57	AR395520	Body manifold	1
58	AR390060	O-Ring	1
59	<i>AR395020</i>	<i>Body manifold</i>	<i>1</i>
60	AR394870	Plug	1
61	AR770260	O-Ring	1
70	AR392120	Pin	1
71	<i>AR880581</i>	<i>Plug</i>	<i>2</i>
84	<i>AR395390</i>	<i>Nut</i>	<i>1</i>
96	<i>AR396100</i>	<i>Filter cover</i>	<i>1</i>
97	<i>AR395081</i>	<i>O-Ring - Viton</i>	<i>1</i>
98	AR395071	Filter gasket	2
99	AR396110	Internal filter	1
100	AR396130	External grid	1
101	<i>AR395030</i>	<i>Filter box</i>	<i>1</i>
102	AR394820	Bracket	1
103	AR770130	O-Ring	1
104	AR392330	Stud	8
105	<i>AR850730</i>	<i>Fork</i>	<i>1</i>
106	AR1660560	Control lever	1
108	<i>AR1660020</i>	<i>Complete valve rod</i>	<i>1</i>
109	<i>AR480561</i>	<i>O-Ring - Viton</i>	<i>2</i>
110	AR1660010	Main valve	1
111	AR1660230	O-Ring	1
112	AR1660541	Spring	1
113	AR1660050	Feed rod valve	1
114	<i>AR1660090</i>	<i>Spring</i>	<i>1</i>
115	AR1660080	Guide	1
116	AR393790	Washer	1
117	AR1660060	Flange	1
118	<i>AR1660100</i>	<i>Red seat</i>	<i>1</i>
118	<i>AR1660110</i>	<i>Orange seat</i>	<i>1</i>
118	<i>AR1660120</i>	<i>Blue seat</i>	<i>1</i>
119	AR1660140	Washer	1
120	<i>AR1660551</i>	<i>O-Ring - Viton</i>	<i>1</i>
129	<i>AR396590</i>	<i>Plug & gasket</i>	<i>1</i>

NOTE

Parts in Italics are non-stocked items and may need to be ordered.

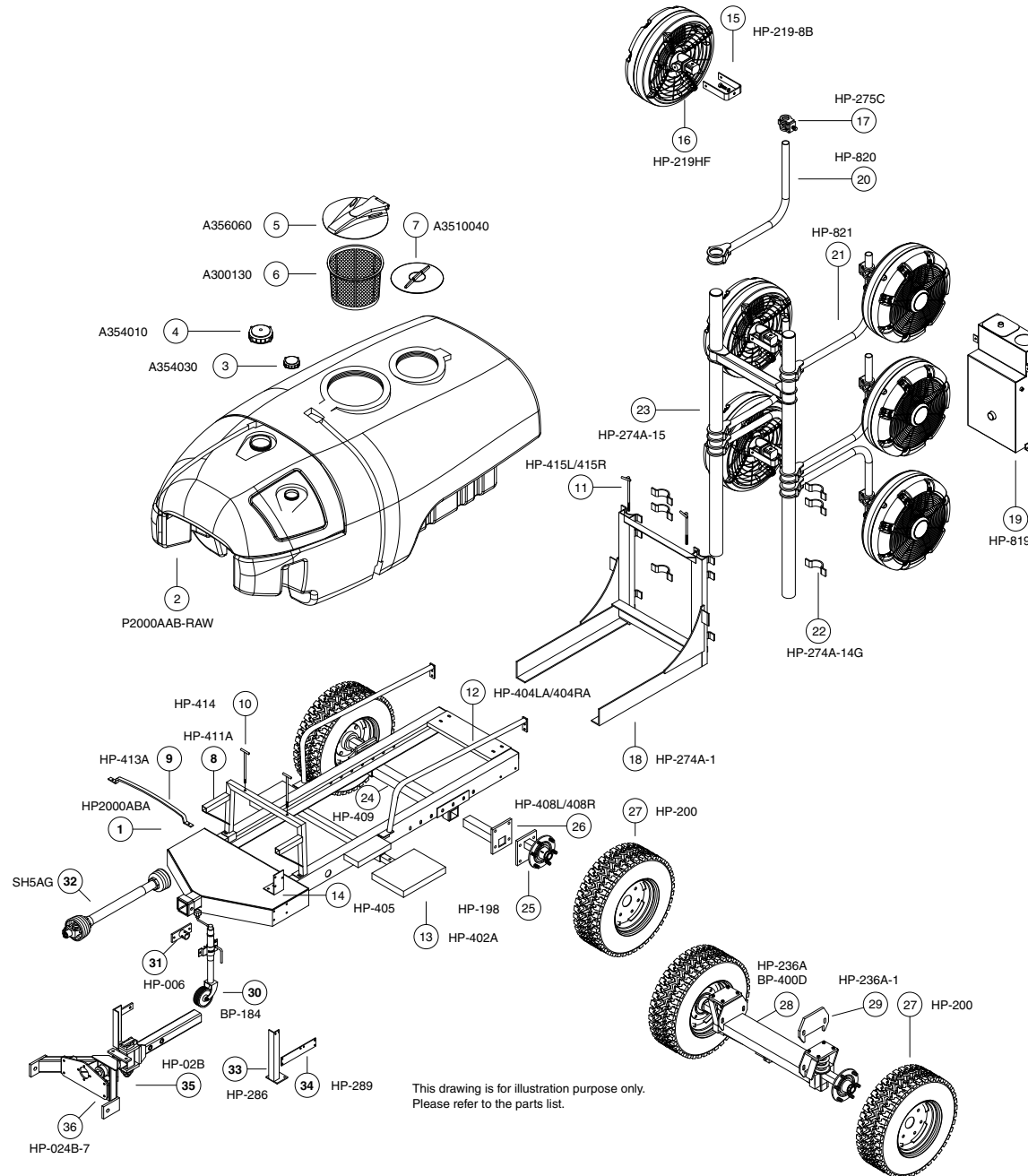

This drawing is for illustration purpose only. Please refer to the parts list.

NOTE

This drawing is for illustration purposes only. Please refer to the parts list.

Pos	Part No	Description	Qty
1	HP2000ABA	CHASSIS 2000LT AIRBLAST	1
2	P2000AAB-RAW	TANK 2000LT POLY AIRBLAST	1
3	A354030	LID 4" c/w BREATHER & SEAL	1
4	A354010	LID 6" c/w BREATHER & SEAL	1
5	A356060	LID, HINGED 180degrees 382mm	1
6	A300130	FILTER BASKET 254mm DEEP	1
7	A3522040	LID, MEDIUM 355mm	1
8	HP-411A	FRONT TANK SUPPORT	1
9	HP-413A	TANK SPREADER BAR	1
10	HP-414	TIE DOWN ROD, FRONT	2
11	HP-415L	TIE DOWN ROD-L.H. REAR	1
	HP-415R	TIE DOWN ROD-R.H. REAR	1
12	HP-404LA	SIDE RAIL, L.H.	1
	HP-404RA	SIDE RAIL, R.H.	1
13	HP-402A	STEP, RETRACTABLE	1
14	HP-405	FILTER BRACKET	1
15	HP-219-8B	U BRACKET STAINLESS STEEL	6
16	HP-219K	QM500 FAN 9.8CC	6
17	HP-275C	CLAMP, QUICK ADJUST	6
	HP-275C-1	CLAMP MOUNT QM500	
	HP-275C-2	CLAMP MOUNT QM380	
18	HP-274A-1	TOWER BRACKET 2000LT	1
19	HP-819	HYDRAULIC TANK	1
20	HP-820	HOOK BRACKET 600MM	3
21	HP-821	HOOK BRACKET 700MM	3
22	HP-274A-14G	CLAMP, HALF SADDLE 90MM	6
23	HP-274A-15	TOWER ASSEMBLY 1500/2000LT	1

Pos	Part No	Description	Qty
24	HP-409	AXLE HOUSING	1
25	HP-198	STUB AXLE/HUB	2
26	HP-408AL	AXLE ADJUSTABLE L.H.	1
	HP-408AR	AXLE ADJUSTABLE R.H.	1
27	HP-200	TYRE AND RIM	2
28	HP-236F	SUSPENSION AXLE OPTION	1
	BP-400D	SUSPENSION TANDEM AXLE	
	BP-400DB	NARROW TANDEM AXLE	
29	***	not applicable	*
30	BP-184	JOCKEY STAND (LONG)	1
31	HP-006	SPIGOT PLATE, JOCKEY STAND	1
32	SH1AG/1200	DRIVE SHAFT - STANDARD	1
32	SH5AG	DRIVE SHAFT 85HP - OPTION	1
33	HP-286	BRACKET, CABLE CONTROL	1
34	HP-289	MANIFOLD BRACKET	1
35	HP-024B	SELF STEERING D-BAR W/ GB MOUNT	1
36	HP-024B-7	MOUNTING PLATE GEARBOX	1

NOTE

Parts in Italics are non-stocked items and may need to be ordered.

Pos	Part No	Description	Qty
1	HP2000ABSL	CHASSIS 2000LT AIRBLAST	1
2	P2000SAB-RAW	TANK 2000LT POLY AIRBLAST	1
3	HP-800	PUMP COVER	1
4	P80AB-RAW	FLUSH TANK	1
5	A356060	LID, HINGED 180degrees 382mm	1
6	A300130	FILTER BASKET 254mm DEEP	1
7	A3522221	LID,SMALL	1
8	HP-823	FILTER MOUNTING BRACKET	1
9	HP-824	BALL VALVE BRACKET	1
10	HP-825	MANIFOLD STAND	1
11	HP-826	MANIFOLD PLATE	1
12	HP-828	SUMP GUARD	1
13	HP-219-8B	U BRACKET STAINLESS STEEL	6
14	HP-219K	QM500 FAN 9.8CC	6
15	HP-275C	CLAMP, QUICK ADJUST	6
	HP-275C-1	CLAMP MOUNT QM500	
	HP-275C-2	CLAMP MOUNT QM380	
16	HP-283C2	TOWER BRACKET ASSEMBLY 2000LT	1
17	HP-274A-15	MAIN TOWER ASSEMBLY 1500/2000LT	1
18	HP-822	TOWER SUPPORT 6 HEAD	1
19	HP-819	HYDRAULIC TANK	1
20	HP-820	HOOK BRACKET 600MM	3
21	HP-821	HOOK BRACKET 700MM	3
22	HP-274A-14G	CLAMP, HALF SADDLE 90MM	6
23	HP-808AL	AXLE L.H.	1
	HP-808AR	AXLE R.H.	1
24	HP-803L	MUDSCRAPER L.H.	1

Pos	Part No	Description	Qty
	HP-803R	MUDSCRAPER R.H.	1
25	HP-803-1	ARM, MUDSCRAPER	2
26	HP-200A	TYRE AND RIM	2
27	BP-184	JOCKEY STAND (LONG)	1
28	HP-006	SPIGOT PLATE, JOCKEY STAND	1
29	XBMBB75	U-BOLT 75MM	2
30	HP-024B	SELF STEERING D-BAR W/ GB MOUNT	1
31	HP-024B-7	MOUNTING PLATE GEARBOX	1

NOTE

Parts in *Italics* are non-stocked items and may need to be ordered.

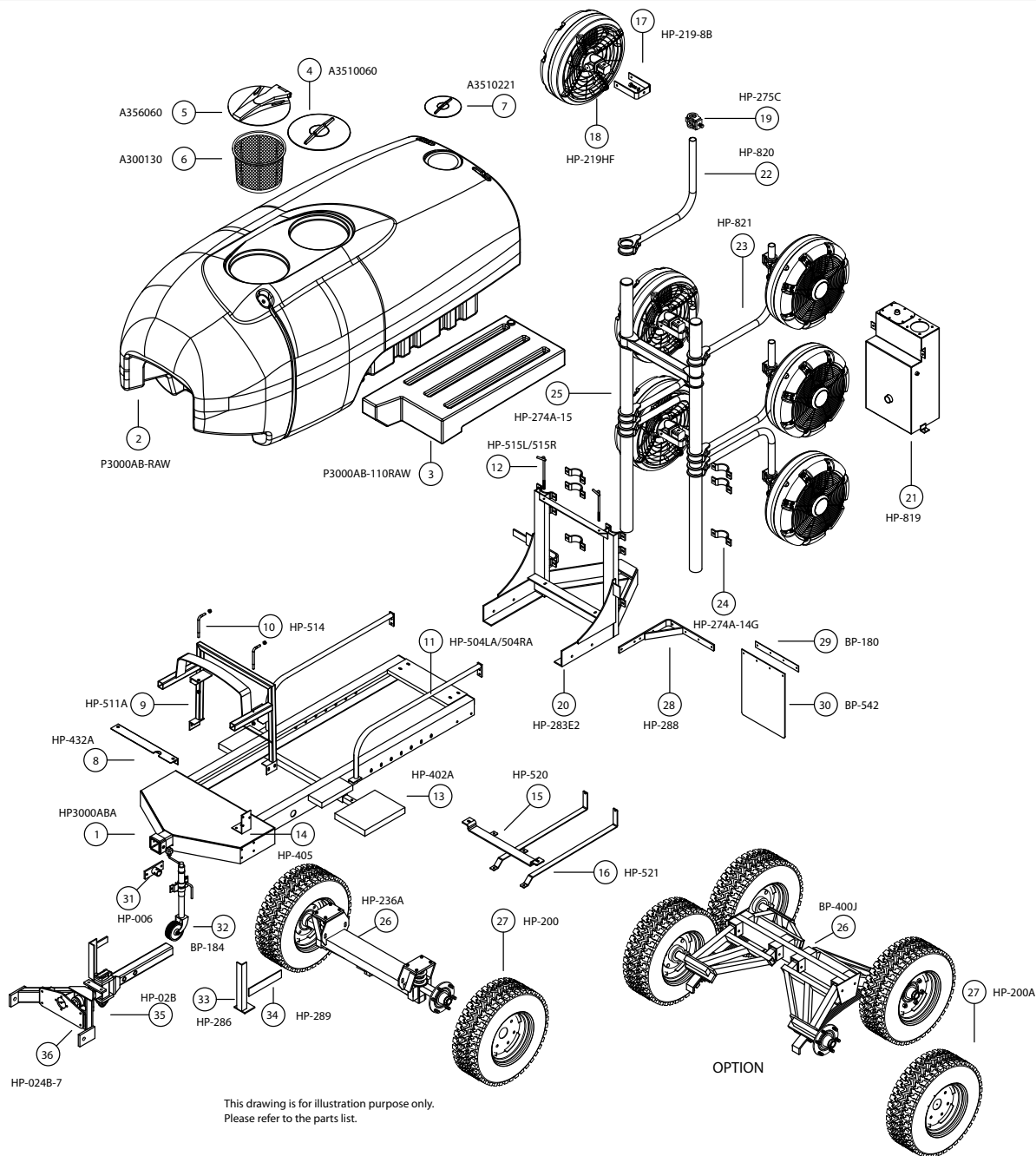

NOTE

This drawing is for illustration purposes only. Please refer to the parts list.

Pos	Part No	Description	Qty
1	HP3000ABA	CHASSIS FRAME	1
2	P3000AB-RAW	TANK	1
3	P3000AB-110RAW	FLUSH TANK 110LT	1
4	A3510060	LID/RING KIT 455MM	1
5	A356060	HINGED LID	1
6	A300130	FILTER BASKET LARGE	1
7	A3510221	LID/RING KIT 255MM	1
8	HP-432A	BRAGLIA VALVE BRACKET	1
9	HP-511A	FRONT TANK SUPPORT	1
10	HP-514	TIE DOWN ROD, FRONT	2
11	HP-504LA	SIDE RAIL, L.H.	1
	HP-504RA	SIDE RAIL, R.H.	1
12	HP-515L	TIE DOWN ROD-REAR L.H.	1
	HP-515R	TIE DOWN ROD-REAR R.H.	1
13	HP-402A	STEP, RETRACTABLE	1
14	HP-405	FILTER BRACKET	1
15	HP-520	CROSS RAIL BRACKET	1
16	HP-521	SUPPORT STRAP	2
17	HP-219-8B	U BRACKET STAINLESS STEEL	6
18	HP-219K	QM500 FAN 9.8CC	6
19	HP-275C	CLAMP, QUICK ADJUST	6
	HP-275C-1	CLAMP MOUNT QM500	
	HP-275C-2	CLAMP MOUNT QM380	
20	HP-283E2	TOWER BRACKET 3000LT	1
21	HP-819	HYDRAULIC TANK	1
22	HP-820	HOOK BRACKET 600MM	3
23	HP-821	HOOK BRACKET 700MM	3

Pos	Part No	Description	Qty
24	HP-274A-14G	CLAMP, HALF SADDLE 90MM	6
25	HP-274A-15	MAIN TOWER ASSEMBLY 1500/2000LT	1
26	HP-236F	SUSPENSION AXLE OPTION	1
	BP-400JA	SUSPENSION TANDEM AXLE	1
27	HP-200	TYRE AND RIM	2
	HP-200A	TYRE AND RIM [Option]	4
28	HP-288	MUDGUARD BRACKET [Option]	2
29	BP-180	MUDFLAP PLATE [Option]	2
30	BP-542	MUDFLAP [Option]	2
31	HP-006	SPIGOT PLATE, JOCKEY STAND [Option]	1
32	BP-184	JOCKEY STAND (LONG)	1
33	HP-286	BRACKET, CABLE CONTROL	1
34	HP-289	MANIFOLD BRACKET	1
35	HP-024B	SELF STEERING D-BAR W/ GB MOUNT	1
36	HP-024B-7	MOUNTING PLATE GEARBOX	1

NOTE

Parts in *Italics* are non-stocked items and may need to be ordered.

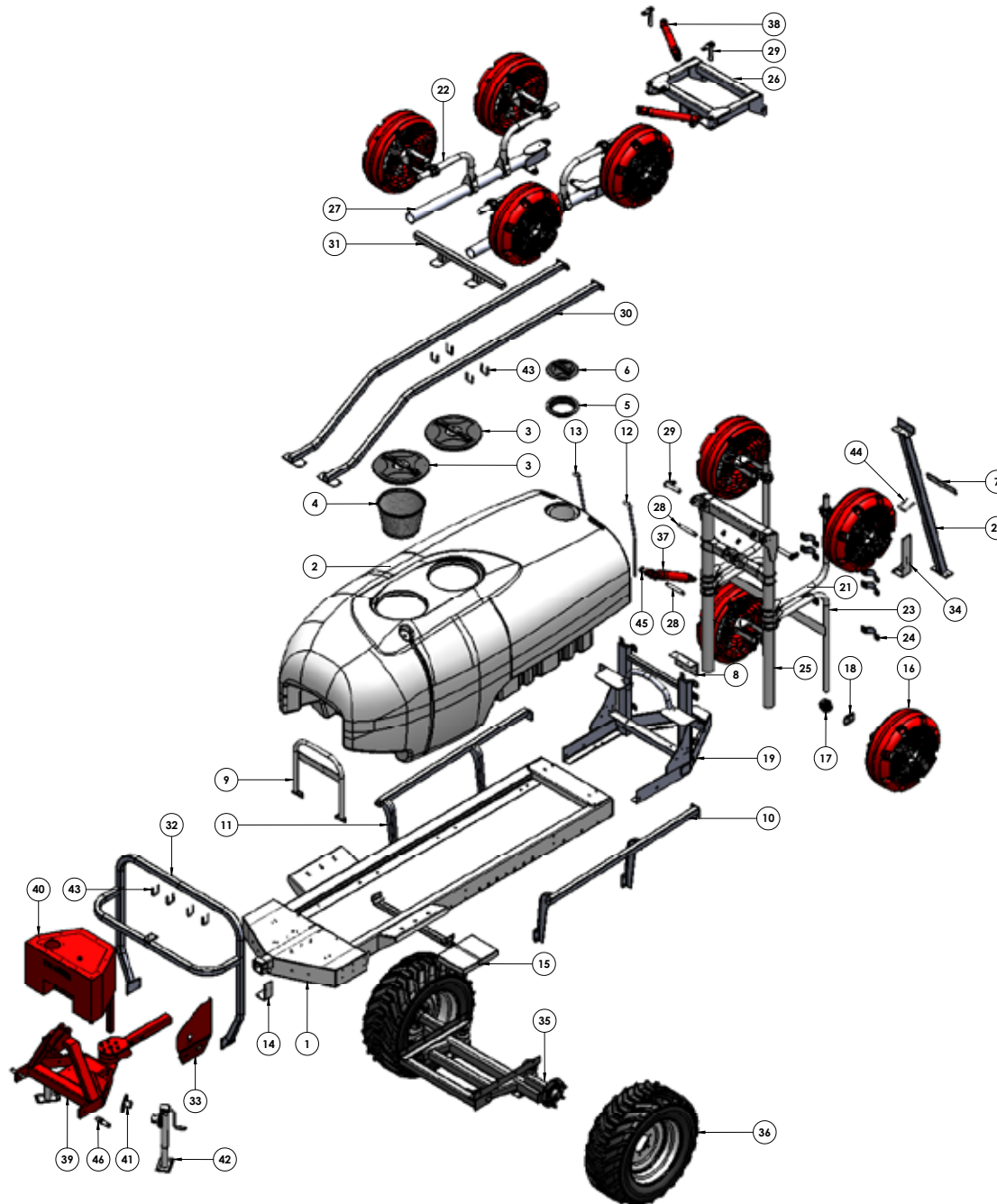

NOTE

This drawing is for illustration purposes only. Please refer to the parts list.

Pos	Part No	Description	Qty
1	HP4000ABA	CHASSIS 4000LT AIRBLAST HAYLITE	1
2	P4000AB-RAW	4000LT TANK POLY AIRBLAST RAW	1
3	A3510060	LID/RING KIT 455MM	2
4	A300130	FILTER BASKET LARGE 254MM DEEP	1
5	A350620	LID RING WITH GASKET	1
6	A3522120	LID ONLY 255MM CLOSED	1
7	HP-289	MANIFOLD BRACKET A463CCRO08A	1
8	HP-229	MANIFOLD BRACKET HP-223C2	1
9	HP-711A	FRONT TANK SUPPORT 4000LT	1
10	HP-704LA	SIDE RAIL L.H. 4000LT HAYLITE	1
11	HP-704RA	SIDE RAIL R.H. 4000LT HAYLITE	1
12	HP-715L	TIE DOWN ROD L.H. 4000LT	1
13	HP-715R	TIE DOWN ROD R.H. 4000LT	1
14	HP-405	BRACKET FILTER SUCTION	1
15	HP-702A	STEP, RETRACTABLE 4000LT	1
16	HP-219K	QM500 FAN RP 9.8 MOTOR c/w SWIVELS	8
17	HP-275C	CLAMP QUICK ADJUST QM VER2	8
18	HP-275C-1	PLATE QUICK ADJUST CLAMP	8
19	HP-283D	SUB FRAME QM 4000LT	1
20	HP-283D-1	TOWER SUPPORT BRACE QM	1
21	HP-820	BRACKET QM HOOK TYPE 600 X 800	2
22	HP-827	BRACKET QM HOOK TYPE 300 X 600	4
23	HP-829	BRACKET QM HOOK TYPE 600 X 1000	2
24	HP-274A-14G	CLAMP HALF SADDLE 90MM GALVANISED	6
25	HP-730A	TOWER CITRUS BOTTOM HALF VER2	1
26	HP-731B	TOWER CITRUS TOP HALF TILT ADJUST	1
		TOWER CITRUS TOP HALF FIXED VER2 (option)	1
27	HP-731B-1	TILT ARM CITRUS TOWER HP-731B	2
28	HP-731B-2	PIN CITRUS TOWER HP-731B	2
29	HP-731B-3	PIN 30 X 165 CITRUS TOWER	4
30	HP-732	TOP BRACE CITRUS	2
31	HP-733	PARKING ARM CITRUS	1
32	HP-721	VALVE BRACKET 4000LT	1
33	HP-721-1	VALVE PANEL CITRUS	1

Pos	Part No	Description	Qty
34	HP-722	BRACKET OIL COOLER CITRUS	1
35	HP-236CLA	SUSPENSION AXLE OPTION	1
	BP-400ADLA	SUSPENSION TANDEM AXLE	1
36	HP-202H	WHEEL/TYRE 400 X 22.5 FLOTATION TYRE	2
	HP-200	RIM/TYRE AWT 11.5/80-15.3 (BP-400ADL option only)	4
	HP-288	BRACKET MUDFLAP (BP-400ADL option only)	2
	BP-180	MUDFLAP PLATE (BP-400ADL option only)	2
	BP-542	MUDFLAP WHITE (BP-400ADL option only)	2
37	HP-281	HYDRAULIC CYLINDER 2.5" X 10"	1
38	HP-016	HYDRAULIC CYLINDER 2.0" X 10"	2
39	HP-024C	3 POINT LINKAGE SELF STEER DRAWBAR	1
40	HP-298-11B	TANK HYDRAULIC DRAWBAR BOLT ON	1
41	HP-006	SPIGOT PLATE JACK STAND	2
42	BP-184	JOCKEY STAND LONG	2
43	XBMBB50	U-BOLT 50MM X 10	8
44	XBMBB65	U-BOLT 65MM X 10	1
45	B0006	BARE LINCH PIN 7/16" DIAMETER	4
46	B0102	IMPLEMENT PIN CAT 2	2

NOTE

Parts in *Italics* are non-stocked items and may need to be ordered.

PART NO: HP-808AL/HP-808AR 2000L HS ADJUSTABLE SOLID SINGLE AXLE

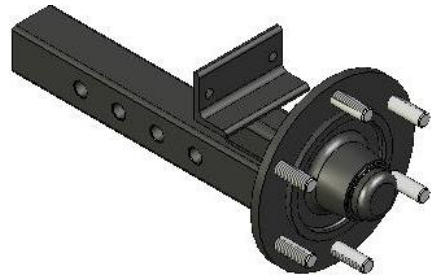

Left hand side stub axle

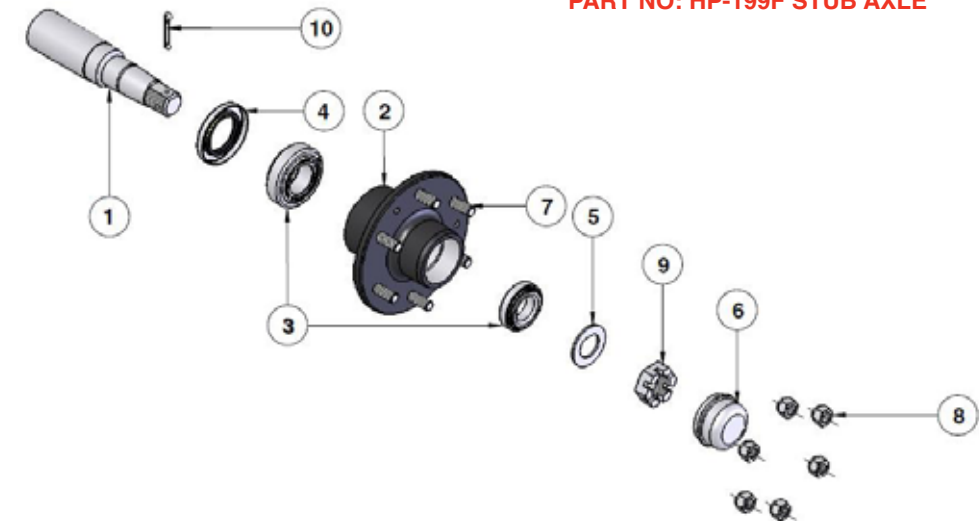

PART NO: HP-199F STUB AXLE

Pos	Part No	Description	Qty
1	HP-199F	STUB AXLE 6STUD 50MM SQUARE	2
2	HP-808AL	ADJUSTABLE STUB AXLE ASSEMBLY LEFTHAND (PIC)	1
3	HP-808AR	ADJUSTABLE STUB AXLE ASSEMBLY RIGHTHAND	1
4	HP-803-1	MUDSCRAPPER ARMS	2
5	HP-803L	MUDSCRAPPER LEFTHAND	1
6	HP-803R	MUDSCRAPPER RIGHTHAND	1
7	MT10013	SPEED SENSOR MOUNTING BRACKET	1

Pos	Part No	Description	Qty
1	HP-199F-1	STUB 50SQ x 338LG	
2	HP-199F-2	HUB DRILLED 6/205PCD	
3	HP-199F-3	BEARING KIT 32209/32206	
4	HP-199F-4	SEAL M85 x 54 x 10	
4a	HP-199F-4A	SEAL RING M46 x 54 x 13 (not shown)	
5	HP-199F-5	FLAT WASHER 1 1/8"	
6	HP-199F-6	DUST CAP (3 screws items 11 & 12)	
7	HP-199F-7	WHEEL STUD M18 x 1.5 x 65	
8	HP-199F-8	WHEEL NUT M18 x 1.5	
9	HP-199F-9	SLOTTED NUT M27 x 2	
10	HP-199F-10	SPLIT PIN M5 x 50	
11	HP-199F-11	SOCKET HEAD CAP SCREW M6 x 30 (not shown)	
12	HP-199F-12	RIB LOCK WASHER M6 (not shown)	

NOTE

Drawing are for illustration purposes only. Please refer to the parts list.

PART NO: HP-198F 1500L/2000L XL ADJUSTABLE SOLID SINGLE AXLE

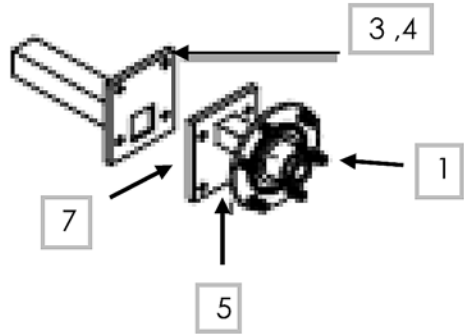

PART NO: HP-199F STUB AXLE

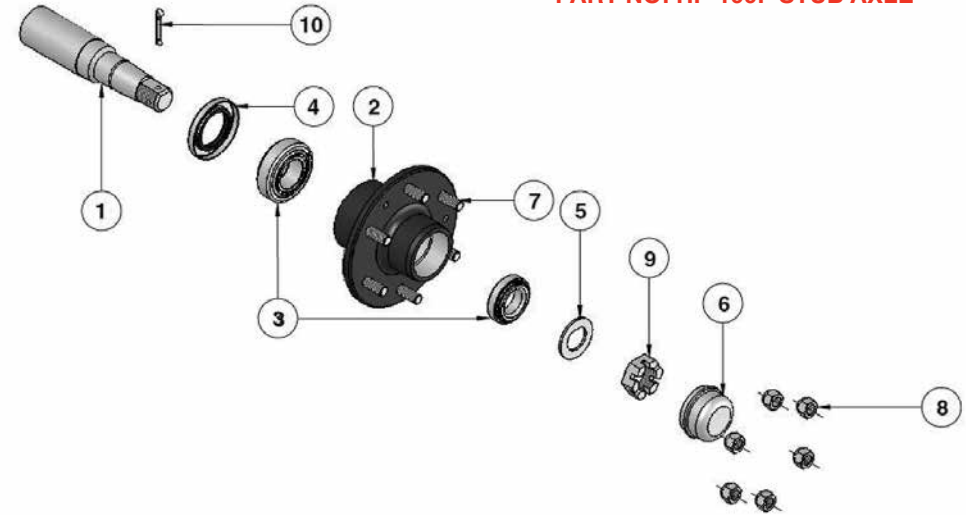

Pos	Part No	Description	Qty
1	HP-199F	STUB AXLE 6STUD 75MM SQUARE	2
2	HP-309	AXLE HOUSING 1500L <i>(not shown)</i>	1
2A	HP-409	AXLE HOUSING 2000L <i>(not shown)</i>	1
3	HP-408L	AXLE ADJUSTABLE LEFT HAND	1
4	HP-408R	AXLE ADJUSTABLE RIGHT HAND	1
5	HP-198B	STUB AXLE / PLATE ASSEMBLY	2
6	MT10013	SPEED SENSOR MOUNTING BRACKET <i>(not shown)</i>	1
7	HP-201	PLATE	2

Pos	Part No	Description	Qty
1	HP-199F-1	STUB 50SQ x 338LG	
2	HP-199F-2	HUB DRILLED 6/205PCD	
3	HP-199F-3	BEARING KIT 32209/32206	
4	HP-199F-4	SEAL M85 x 54 x 10	
4a	HP-199F-4A	SEAL RING M46 x 54 x 13 <i>(not shown)</i>	
5	HP-199F-5	FLAT WASHER 1 1/8"	
6	HP-199F-6	DUST CAP <i>(3 screws items 11 & 12)</i>	
7	HP-199F-7	WHEEL STUD M18 x 1.5 x 65	
8	HP-199F-8	WHEEL NUT M18 x 1.5	
9	HP-199F-9	SLOTTED NUT M27 x 2	
10	HP-199F-10	SPLIT PIN M5 x 50	
11	HP-199F-11	SOCKET HEAD CAP SCREW M6 x 30 <i>(not shown)</i>	
12	HP-199F-12	RIB LOCK WASHER M6 <i>(not shown)</i>	

NOTE

Drawing are for illustration purposes only. Please refer to the parts list.

PART NO: BP-205DA 1500L/2000L SOLID AXLE

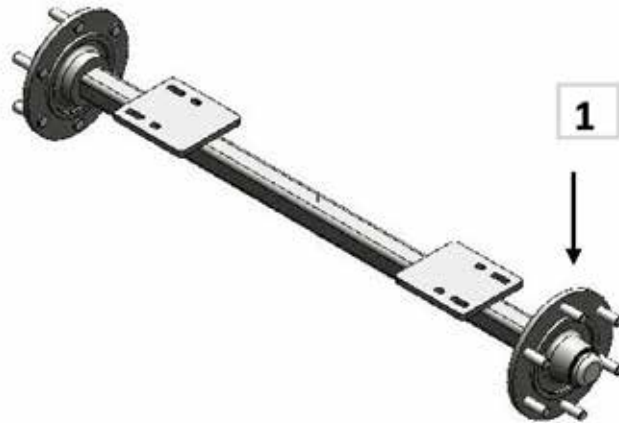

PART NO: HP-199F STUB AXLE

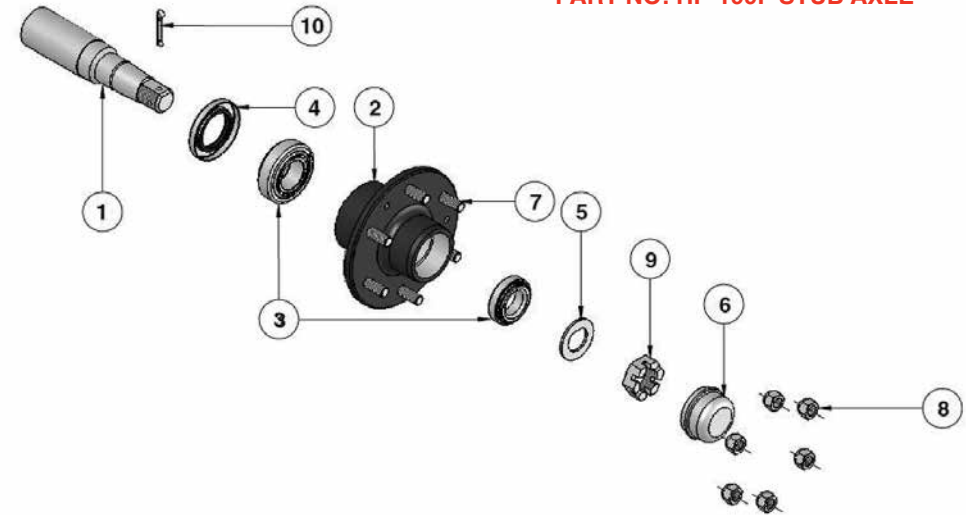

Pos	Part No	Description	Qty
1	HP-199F	AXLE/HUB 6/205 50SQ ANDYS	2
2	HP-205D-1	AXLE BRACKET (not shown)	2
3	MT10013	SPEED SENSOR MOUNTING BRACKET (not shown)	1

Pos	Part No	Description	Qty
1	HP-199F-1	STUB 50SQ x 338LG	
2	HP-199F-2	HUB DRILLED 6/205PCD	
3	HP-199F-3	BEARING KIT 32209/32206	
4	HP-199F-4	SEAL M85 x 54 x 10	
4a	HP-199F-4A	SEAL RING M46 x 54 x 13 (not shown)	
5	HP-199F-5	FLAT WASHER 1 1/8"	
6	HP-199F-6	DUST CAP (3 screws items 11 & 12)	
7	HP-199F-7	WHEEL STUD M18 x 1.5 x 65	
8	HP-199F-8	WHEEL NUT M18 x 1.5	
9	HP-199F-9	SLOTTED NUT M27 x 2	
10	HP-199F-10	SPLIT PIN M5 x 50	
11	HP-199F-11	SOCKET HEAD CAP SCREW M6 x 30 (not shown)	
12	HP-199F-12	RIB LOCK WASHER M6 (not shown)	

NOTE

Drawing are for illustration purposes only. Please refer to the parts list.

PART NO: BP-205B 3000L SOLID AXLE

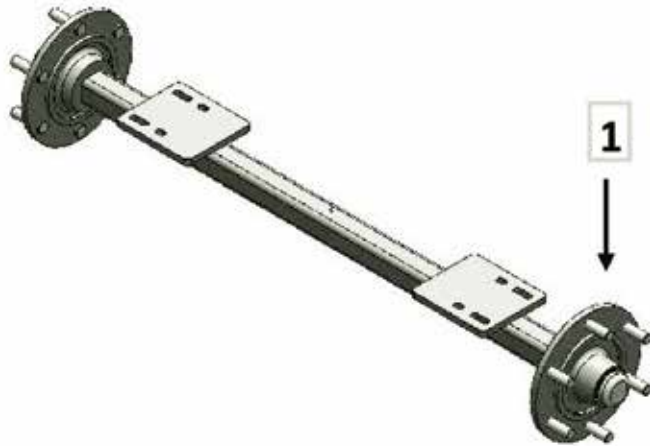

PART NO: HP-199E STUB AXLE

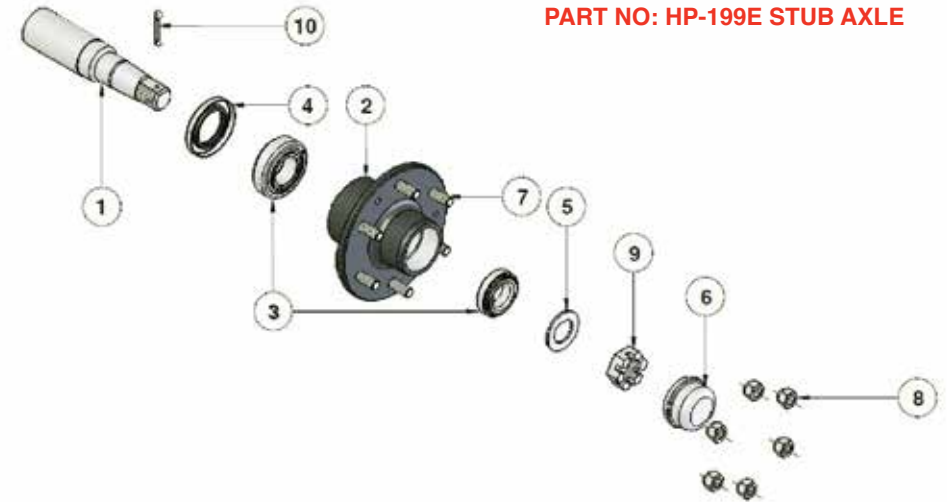

Pos	Part No	Description	Qty
1	HP-199E	AXLE/HUB 6/205 50SQ ANDYS	2
2	MT10013	SPEED SENSOR MOUNTING BRACKET <i>(not shown)</i>	1

Pos	Part No	Description	Qty
1	HP-199E-1	STUB 85SQ x 395LG	
2	HP-199E-2	WHEELHUB 6/205 PCD	
3	HP-199E-3	BEARING KIT 32213/32210	
4	HP-199E-4	TRIPLE LIP SEAL 125 x 90 x 12mm	
4	HP-199E-4A	SEAL RING 70.5x90x16.5mm <i>(not shown)</i>	
4	HP-199E-4B	WEAR RING <i>(to suit T.L.S [not shown])</i>	
5	N/A	N/A	
6	HP-199E-6	DUST CAP <i>(3 screws items 11 and 12)</i>	
7	HP-199E-7	WHEEL STUD M18 x 1.5 x 65	
8	HP-199E-8	WHEEL NUT M18 x 1.5	
9	HP-199E-9	SLOTTED/CASTLE NUT M39 x 2	
10	HP-199E-10	SPLIT PIN 60 x 6mm	
11	HP-199E-11	SOCKET HEAD CAP SCREW M8 x 30 <i>(not shown)</i>	
12	HP-199E-12	M8 RIB LOCK WASHERS <i>(not shown)</i>	

NOTE

Drawing are for illustration purposes only. Please refer to the parts list.

PART NO: BP-205A 4000L SOLID AXLE

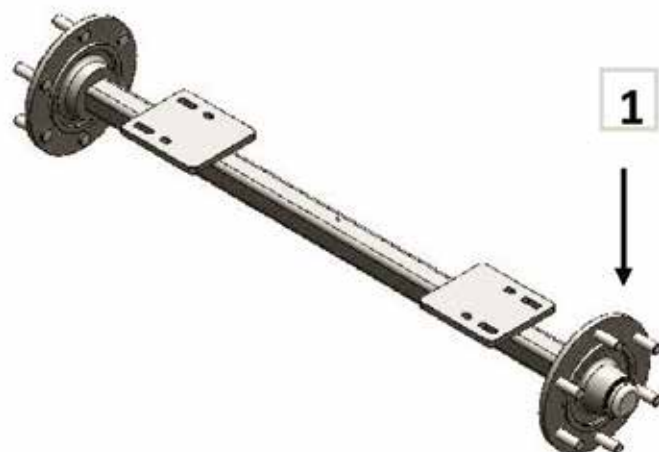

PART NO: HP-199E STUB AXLE

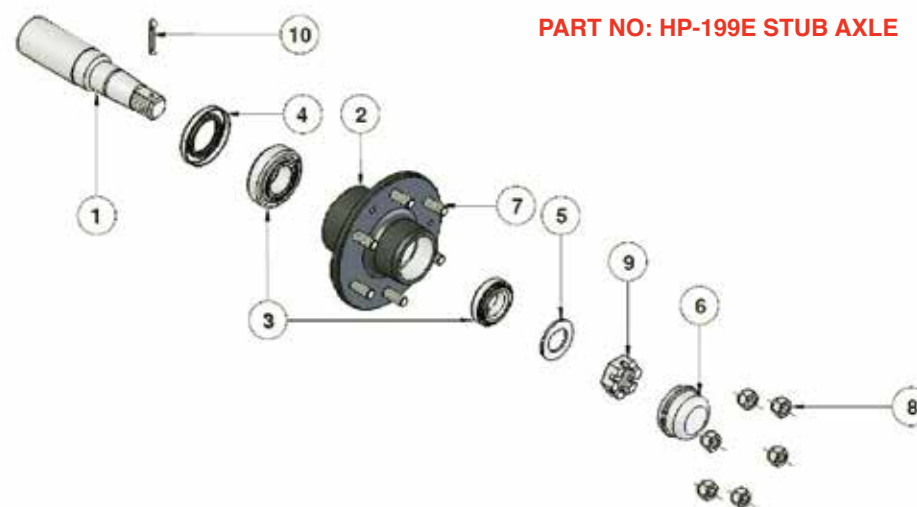

Pos	Part No	Description	Qty
1	HP-199E	AXLE/HUB 6/205 50SQ ANDYS	2
3	MT10013	SPEED SENSOR MOUNTING BRACKET <i>(not shown)</i>	1

Pos	Part No	Description	Qty
1	HP-199E-1	STUB 85SQ x 395LG	
2	HP-199E-2	WHEELHUB 6/205 PCD	
3	HP-199E-3	BEARING KIT 32213/32210	
4	HP-199E-4	TRIPLE LIP SEAL 125 x 90 x 12mm	
4	HP-199E-4A	SEAL RING 70.5 x 90 x 16.5mm <i>(not shown)</i>	
4	HP-199E-4B	WEAR RING <i>(to suit T.L.S [not shown])</i>	
5	N/A	N/A	
6	HP-199E-6	DUST CAP <i>(3 screws items 11 and 12)</i>	
7	HP-199E-7	WHEEL STUD M18 x 1.5 x 65	
8	HP-199E-8	WHEEL NUT M18 x 1.5	
9	HP-199E-9	SLOTTED/CASTLE NUT M39 x 2	
10	HP-199E-10	SPLIT PIN 60 x 6mm	
11	HP-199E-11	SOCKET HEAD CAP SCREW M8 x 30 <i>(not shown)</i>	
12	HP-199E-12	M8 RIB LOCK WASHERS <i>(not shown)</i>	

NOTE

Drawing are for illustration purposes only. Please refer to the parts list.

PART NO: HP-236F 1500L/2000L SUSPENSION SINGLE AXLE

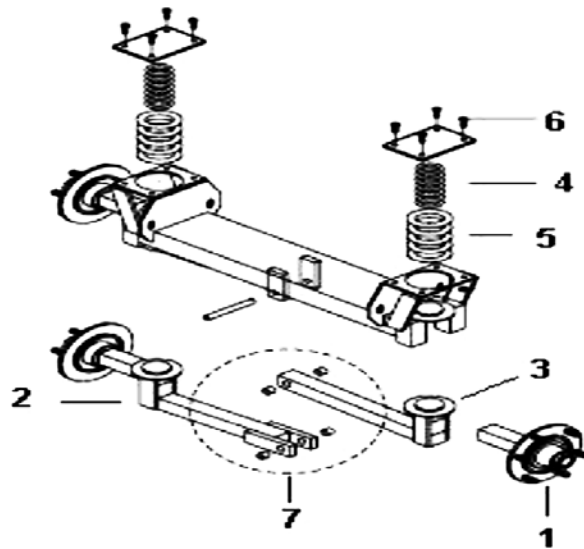

PART NO: HP-199F STUB AXLE

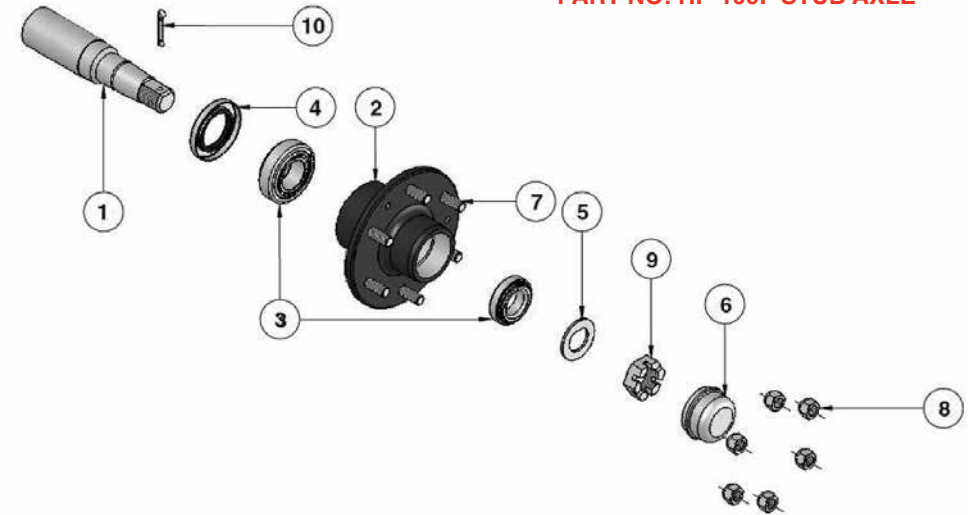

Pos	Part No	Description	Qty
1	HP-199F	STUB AXLE 6STUD 50MM SQUARE	2
2	HP-236FARMC	SUSPENSION ARM (CLEVIS))	1
3	HP-236FARMT	SUSPENSION ARM (TANG)	1
4	HP-271A	SPRING INNER (SMALL)	2
5	HP-271	SPRING OUTER (LARGE)	2
6	XCON	BOLTS M12x35	8
7	HP-236A-2	BRASS BUSH	8
8	HP-236A-1	SPACER FOR 1500L (not shown)	2
9	MT10013	SPEED SENSOR MOUNTING BRACKET (not shown)	1

Pos	Part No	Description	Qty
1	HP-199F-1	STUB 50SQ x 338LG	
2	HP-199F-2	HUB DRILLED 6/205PCD	
3	HP-199F-3	BEARING KIT 32209/32206	
4	HP-199F-4	SEAL M85 x 54 x 10	
4a	HP-199F-4A	SEAL RING M46 x 54 x 13 (not shown)	
5	HP-199F-5	FLAT WASHER 1 1/8"	
6	HP-199F-6	SLOTTED NUT M27 x 2	
7	HP-199F-7	SPLIT PIN M5 x 50	
8	HP-199F-8	DUST CAP (3 screws items 11 & 12)	
9	HP-199F-9	WHEEL STUD M18 x 1.5 x 65	
10	HP-199F-10	WHEEL NUT M18 x 1.5	
11	HP-199F-11	SOCKET HEAD CAP SCREW M6 x 30 (not shown)	
12	HP-199F-12	RIB LOCK WASHER M6 (not shown)	

NOTE

Drawing are for illustration purposes only. Please refer to the parts list.

PART NO: HP-236D 3000L SUSPENSION SINGLE AXLE

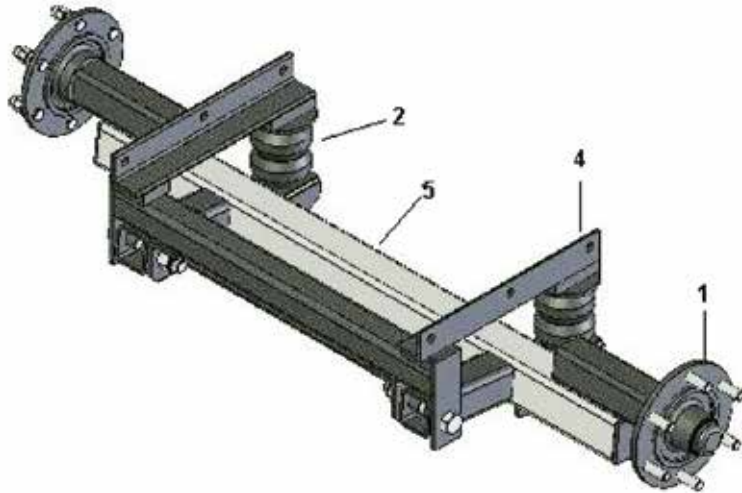

PART NO: HP-199E STUB AXLE

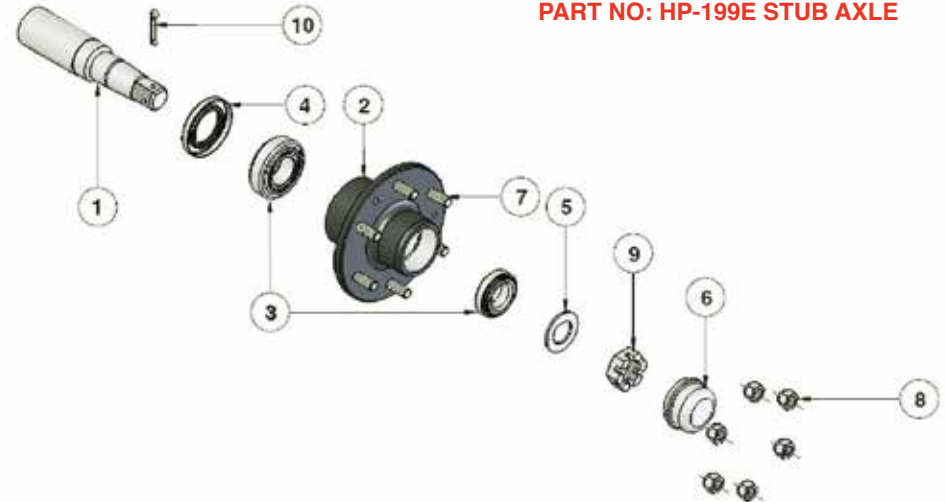

Pos	Part No	Description	Qty
1	HP-199E	STUB AXLE 6STUD 75MM SQUARE	2
2	HP-236CL-1A	RUBBER SPRING A560-65	2
3	HP-236CLA-1A-1	BUSH 32 x 13.5 x 22.5 (not shown)	2
4	HP-236D-1	AXLE HOUSING	1
5	HP-236D-2	AXLE BEAM	1
6	MT10013	SPEED SENSOR MOUNTING BRACKET (not shown)	1

Pos	Part No	Description	Qty
1	HP-199E-1	STUB 75SQ x 395LG	
2	HP-199E-2	WHEELHUB 6/205 PCD	
3	HP-199E-3	BEARING KIT 32213/32210	
4	HP-199E-4	TRIPLE LIP SEAL 125 x 90 x 12mm	
4	HP-199E-4A	SEAL RING 70.5x 90 x 16.5mm (not shown)	
4	HP-199E-4B	WEAR RING (to suit T.L.S [not shown])	
5	N/A	N/A	
6	HP-199E-6	DUST CAP (3 screws items 11 and 12)	
7	HP-199E-7	WHEEL STUD M18 x 1.5 x 65	
8	HP-199E-8	WHEEL NUT M18 x 1.5	
9	HP-199E-9	SLOTTED/CASTLE NUT M39 x 2	
10	HP-199E-10	SPLIT PIN 60 x 6mm	
11	HP-199E-11	SOCKET HEAD CAP SCREW M8 x 30 (not shown)	
12	HP-199E-12	M8 RIB LOCK WASHERS (not shown)	

NOTE

Drawing are for illustration purposes only. Please refer to the parts list.

PART NO: HP-236CLA 4000L SUSPENSION SINGLE AXLE

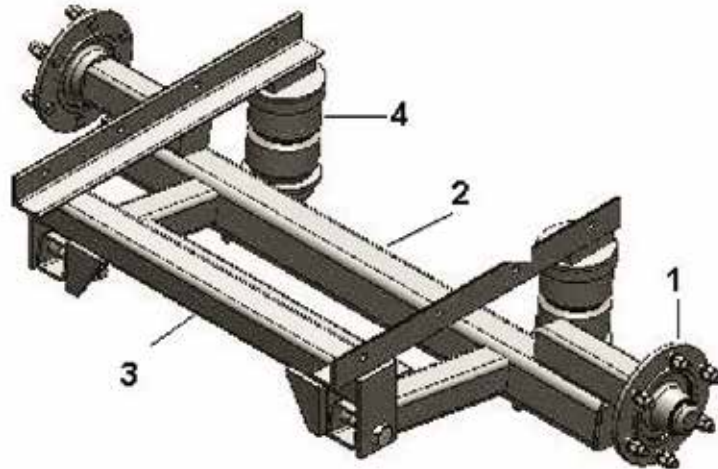

PART NO: HP-199E STUB AXLE

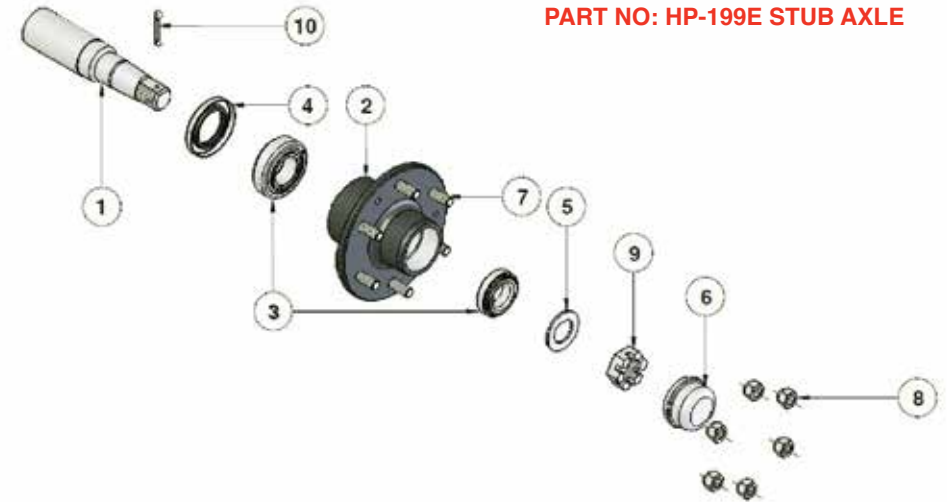

Pos	Part No	Description	Qty
1	HP-199E	STUB AXLE 6STUD 75MM SQUARE	2
2	HP-236CLA-2	AXLE BEAM	1
3	HP-236CLA-1	AXLE HOUSING	1
4	HP-236CL-1A	RUBBER SPRING A560-65	2
5	HP-236CL-1A-1	BUSH 32x13.5X22.5 <i>(not shown)</i>	2
6	MT10013	SPEED SENSOR MOUNTING BRACKET <i>(not shown)</i>	1

Pos	Part No	Description	Qty
1	HP-199E-1	STUB 75SQ x 395LG	
2	HP-199E-2	WHEELHUB 6/205 PCD	
3	HP-199E-3	BEARING KIT 32213/32210	
4	HP-199E-4	TRIPLE LIP SEAL 125 x 90 x 12mm	
4	HP-199E-4A	SEAL RING 70.5 x 90 x 16.5mm <i>(not shown)</i>	
4	HP-199E-4B	WEAR RING <i>(to suit T.L.S [not shown])</i>	
5	N/A	N/A	
6	HP-199E-6	DUST CAP <i>(3 screws items 11 and 12)</i>	
7	HP-199E-7	WHEEL STUD M18 x 1.5 x 65	
8	HP-199E-8	WHEEL NUT M18 x 1.5	
9	HP-199E-9	SLOTTED/CASTLE NUT M39 x 2	
10	HP-199E-10	SPLIT PIN 60 x 6mm	
11	HP-199E-11	SOCKET HEAD CAP SCREW M8 x 30 <i>(not shown)</i>	
12	HP-199E-12	M8 RIB LOCK WASHERS <i>(not shown)</i>	

NOTE

Drawing are for illustration purposes only. Please refer to the parts list.

PART NO: BP-400D 2000L SUSPENSION TANDEM AXLE

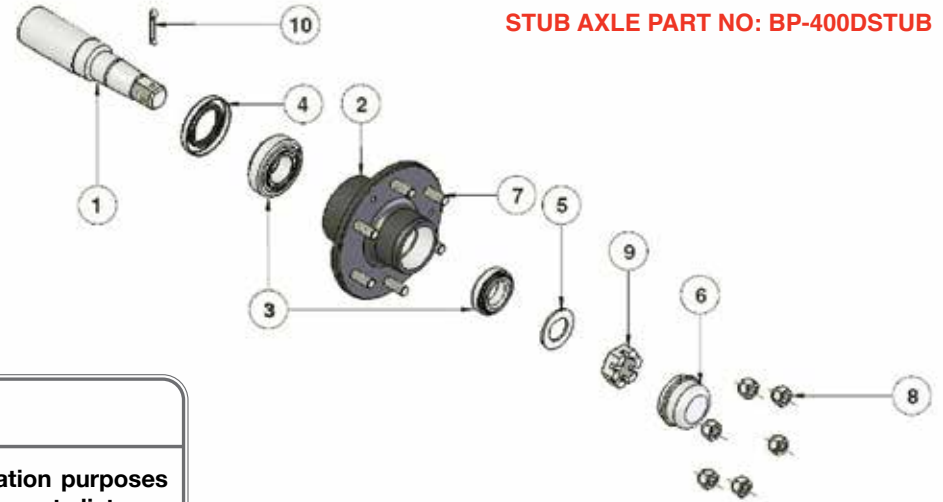
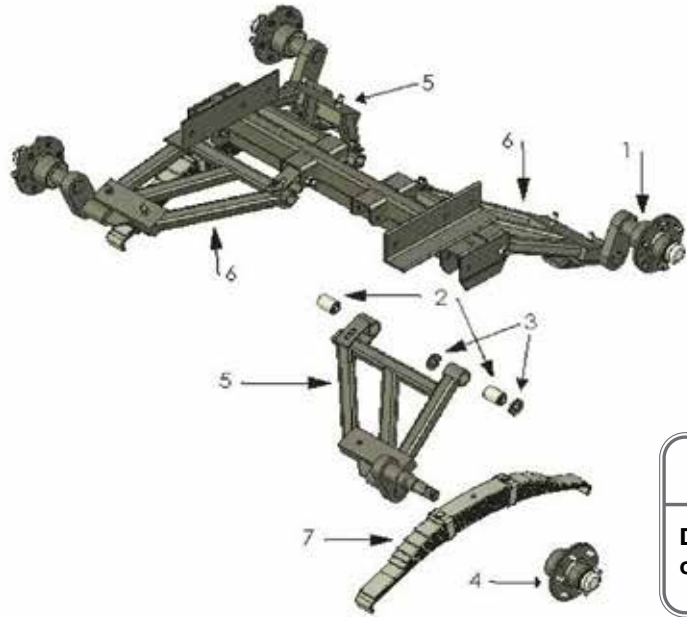

STUB AXLE PART NO: BP-400DSTUB

NOTE

Drawing are for illustration purposes only. Please refer to the parts list.

Pos	Part No	Description	Qty
1	BP-400DSTUB	STUB AXLE 139.7 PCD / 6 STUD (MACHINED)	4
1	BP-400STUB	STUB AXLE 139.7 PCD / 6 STUD (UNMACHINED)	4
2	BP-400-2	PIVOT BUSH TRAILING ARM 5/8"	8
3	BP-400-3	THRUST WASHER	4
4	BP-400-4	HUB COMPLETE (Bearings, Seal & Dust Cap)	4
5	BP-400D-1	TRAILING ARM LEFT FRONT / RIGHT BACK	2
6	BP-400D-2	TRAILING ARM RIGHT FRONT/LEFT BACK	2
7	BP-400DSPRING	SPRING & SEAT ASSEMBLY	2
7a	BP-400SPRING	HEAVY DUTY SPRING ASSY (optional spare part)	2
	BP-400D-7	SPRING CLAMP	4
	BP-400D-7	ANTI RATTLE PLATE	4
	MT10013	SPEED SENSOR MOUNTING BRACKET (not shown)	1

Pos	Part No	Description	Qty
1	BP-400DSTUB-1	ROUND STUB (DROP AXLE MACHINED)	
2	BP-400DSTUB-2	HUB	
3	BP-400DSTUB-3	BEARING KIT 2788 /2720 + LM67048 /LM67010	
4	BP-400DSTUB-4	DUST SEAL 3" x 1 7/8" x 3/8"	
5	BP-400DSTUB-5	KEYED WASHER 1 1/4"	
6	BP-400DSTUB-6	DUST CAP 59mm	
7	BP-400DSTUB-7	WHEEL STUD 1/2"	
8	BP-400DSTUB-8	WHEEL NUT 1/2"	
9	BP-400DSTUB-9	SLOTTED NUT 1 1/4" UNF	
10	BP-400DSTUB-10	SPLIT PIN 50 x 5mm	

PART NO: BP-400JA 3000L SUSPENSION TANDEM AXLE (ATS)

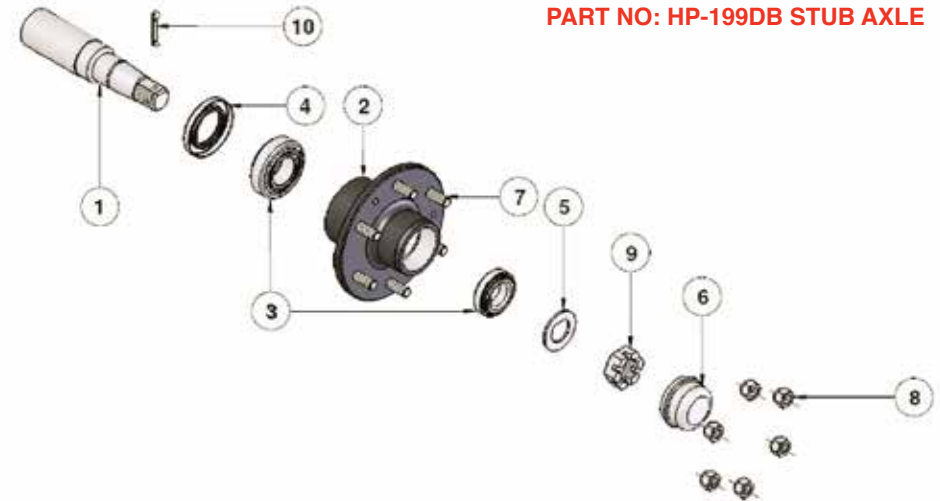
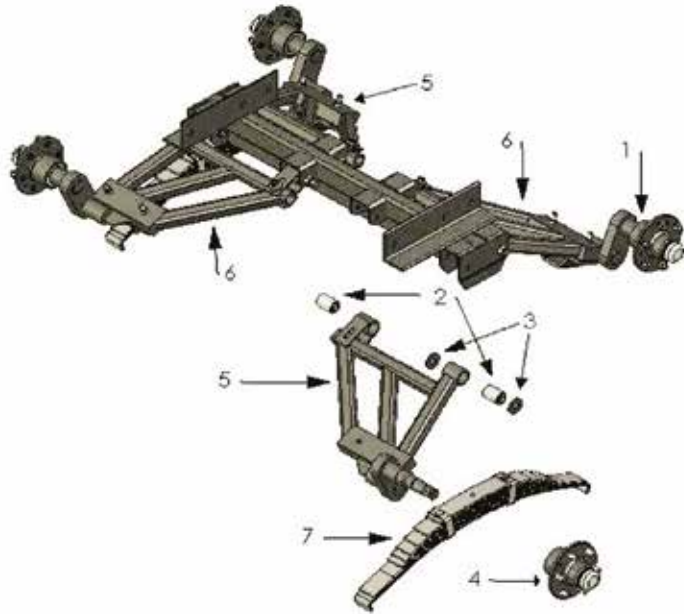

PART NO: HP-199DB STUB AXLE

Pos	Part No	Description	Qty
1	HP-199DB	STUB AXLE 65MM ROUND 6/205PCD	4
2	BP-400-2	PIVOT BUSH TRAILING ARM 5/8"	8
3	BP-400-3	THRUST WASHER	4
4	N/A	Refer stub axle	
5	BP-400J-1	TRAILING ARM LEFT FRONT/RIGHT BACK (no hub)	2
6	BP-400J-2	TRAILING ARM RIGHT FRONT/LEFT BACK (no hub)	2
7	BP-400JLSPRING	SPRING ASSY (NO SEAT)	2
	BP-400JSRING	SPRING ASSY BP-400J	
8	MT10013	SPEED SENSOR MOUNTING BRACKET (not shown)	1

Pos	Part No	Description	Qty
1	HP-199DA-1	STUB AXLE 65RD x 438LG (NOT MACHINED)	
2	HP-199DA-2	HUB 6/205PCD	
3	HP-199DA-3	BEARING KIT 30208/30211	
4	HP-199DA-4	TRIPLE LIP SEAL 100 x 70 x 12mm	
4a	HP-199DA-4A	SEAL RING 57 x 70.5 x 16.5mm (not shown)	
4b	HP-199DA-4B	WEAR RING TO SUIT T.L.S (not shown)	
5	N/A	N/A	
6	HP-199DA-6	DUST CAP (3 screws items 11 and 12)	
7	HP-199DA-7	WHEEL STUD M18 x 1.5 x 65	
8	HP-199DA-8	WHEEL NUT M18 x 1.5	
9	HP-199DA-9	SLOTTED NUT M33 x 2	
10	HP-199DA-10	SPLIT PIN M50x6	
11	HP-199DA-11	SOCKET HEAD CAP SCREW M8 x 25 (not shown)	
12	HP-199DA-12	RIB LOCK WASHER M8 (not shown)	

NOTE

Drawing are for illustration purposes only. Please refer to the parts list.

PART NO: BP-400ADLA 4000L SUSPENSION TANDEM AXLE (Acutec)

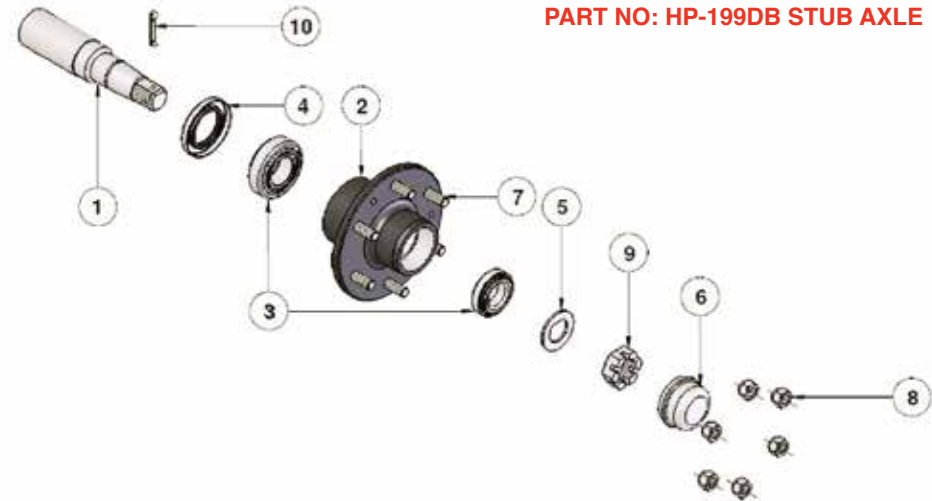
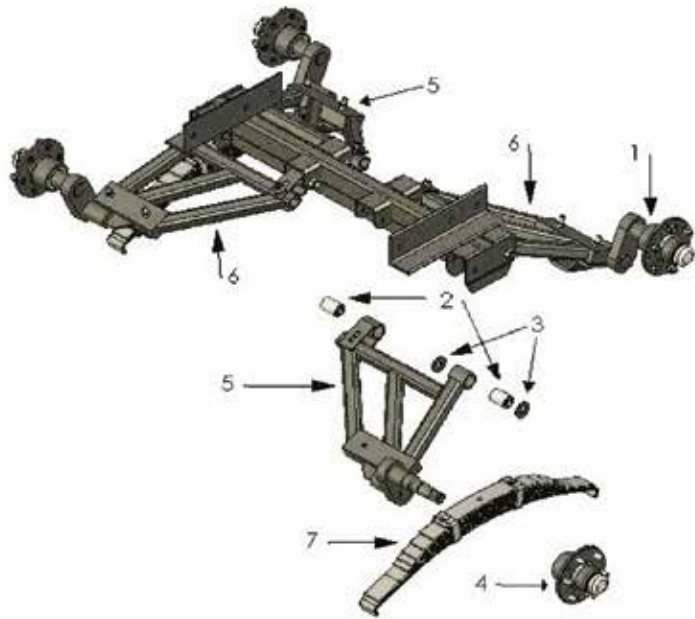

PART NO: HP-199DB STUB AXLE

Pos	Part No	Description	Qty
1	HP-199DB	STUB AXLE 65MM ROUND 6/205PCD (machined)	4
2	BP-400-2	PIVOT BUSH TRAILING ARM 5/8"	8
3	BP-400-3	THRUST WASHER	4
4	N/A	Refer stub axle	
5	BP-400AD-1	TRAILING ARM LEFT FRONT/RIGHT BACK (no hub)	2
6	BP-400AD-2	TRAILING ARM RIGHT FRONT/LEFT BACK (no hub)	2
7	BP-400ADLSPRING	SPRING 9 LEAF (no seat)	2
7	BP-400ADSPRING	SPRING & SEAT ASSY BP-400ADL	2
8	MT10013	SPEED SENSOR MOUNTING BRACKET (not shown)	1

Pos	Part No	Description	Qty
1	HP-199DA-1	STUB AXLE 65RD x 438LG (non machined)	
2	HP-199DA-2	HUB 6/205PCD	
3	HP-199DA-3	BEARING KIT 30208/30211	
4	HP-199DA-4	TRIPLE LIP SEAL 100 x 70 x 12mm	
4a	HP-199DA-4A	SEAL RING 57 x 70.5 x 16.5mm (not shown)	
4b	HP-199DA-4B	WEAR RING TO SUIT T.L.S (not shown)	
5	N/A	N/A	
6	HP-199DA-6	DUST CAP (3 screws items 11 and 12)	
7	HP-199DA-7	WHEEL STUD M18 x 1.5 x 65	
8	HP-199DA-8	WHEEL NUT M18 x 1.5	
9	HP-199DA-9	SLOTTED NUT M33 x 2	
10	HP-199DA-10	SPLIT PIN M50 x 6	
11	HP-199DA-11	SOCKET HEAD CAP SCREW M8 x 25 (not shown)	
12	HP-199DA-12	RIB LOCK WASHER M8 (not shown)	

NOTE

Drawing are for illustration purposes only. Please refer to the parts list.

SARDI Fans



PART No.	DESCRIPTION	DATE
HP-011DA	FAN – SARDI 500mm (It)	2007 - 2009
HP-011D	FAN – SARDI 500mm (Ch)	2009 - 2012
HP-011DB	FANJ – SARDI 500mm (Ch)	2012+



PART No.	DESCRIPTION	DATE
HP-119-10	FAN – SARDI 380mm (Aust)	2007 - 2010
HP-119-10A	FAN – SARDI 380mm (Ch)	2010 -

NOTE

This drawing is for illustration purposes only. Please refer to the parts list.

Quantum Mist, QM-500 Spray Head Assembly (2007 - Current)

Drive Body, HP-219-9D

The fully assembled drive body is now a stand alone, "non serviceable part".



Includes HP-219-25 Coupler (ex FISEM10)



NOTE

The Drive Body, HP-219-9D will fit spray heads back to 2004. Prior to 2004 is now classified as obsolete.

NOTE

The motor shown in this picture is the 6.5cc version (HP-219M6.5CE) (which is used in some QM-500 applications (citrus)).

The only visible difference is the length of the main body - the red section of the 6.5cc motor is 60mm long.

Hydraulic Motor:

- HP-219M9.8CE
The bare hydraulic (rear port) motor

OR

- HP-219M9.8CE-1,
The HP-219M9.8CE motor combined with:

- Locating ring - HP-219-4A, and
- Splined coupler - HP-219-24 (male) (ex FISEM 09)



HP-219M9.8CE

HP-219-4A
Locating Ring



HP-219-24 (male) Coupling
(ex FISEM 09)



HP-219M9.8CE-1



Use motor housing bolts:
M6 x 25 SS bolts + washers

NOTE

In some cases the motor supplied will be painted in a protective black epoxy coating.

QM500 Spray Head Assembly



4

Versions 5B & 5C
look similar

Version 5A

2

Pos	Part No	Description
1	HP-219-3B	Fan Cowling - Front & Rear (Sold as a matched pair, red colour)
2	HP-219-6B	Front Guard (Powder coated, stainless steel, black colour)
3	HP-219-7B	Rear Guard (Powder coated, stainless steel, black colour)
4	HP-219-5D	Spray Ring (stainless steel) - See notes the different versions
5	HP-219-15B	Centre Cover Plate (Incorporates the Croplands/SARDI Label)
6	HP-219-20	Retaining Flange (Note there are 2 versions (cast or machined))

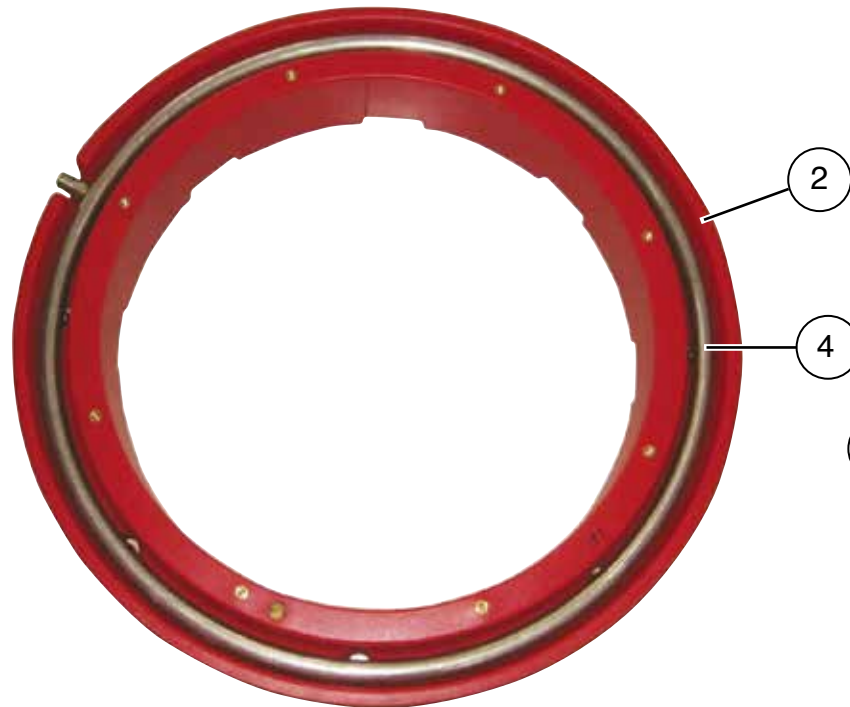

2

4

5

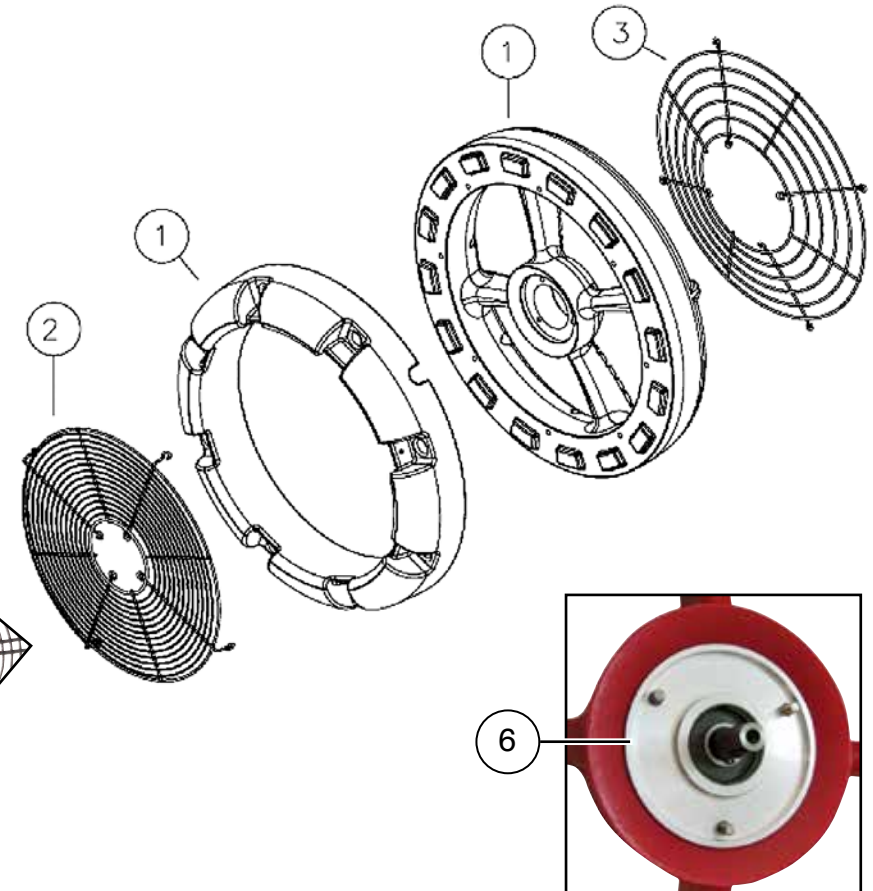



Shaft bolt M8 x 25 SS,
spring washer & large
flat washer

Fan bolts M8 x 30 SS,
spring washers & flat
washers

Mounting Hub
HP-219-16C

Fan HP-011D



Mounting bolts M12 x 40 SS &
spring washers

Mounting Bracket
HP-219-8B

Drive Body
HP-219-9D



Swivels



Single, HP-219-22A / B264.612.172



Shut off nozzle, B67.617.67



Double nozzle, HP-219-23 / B264.612.171

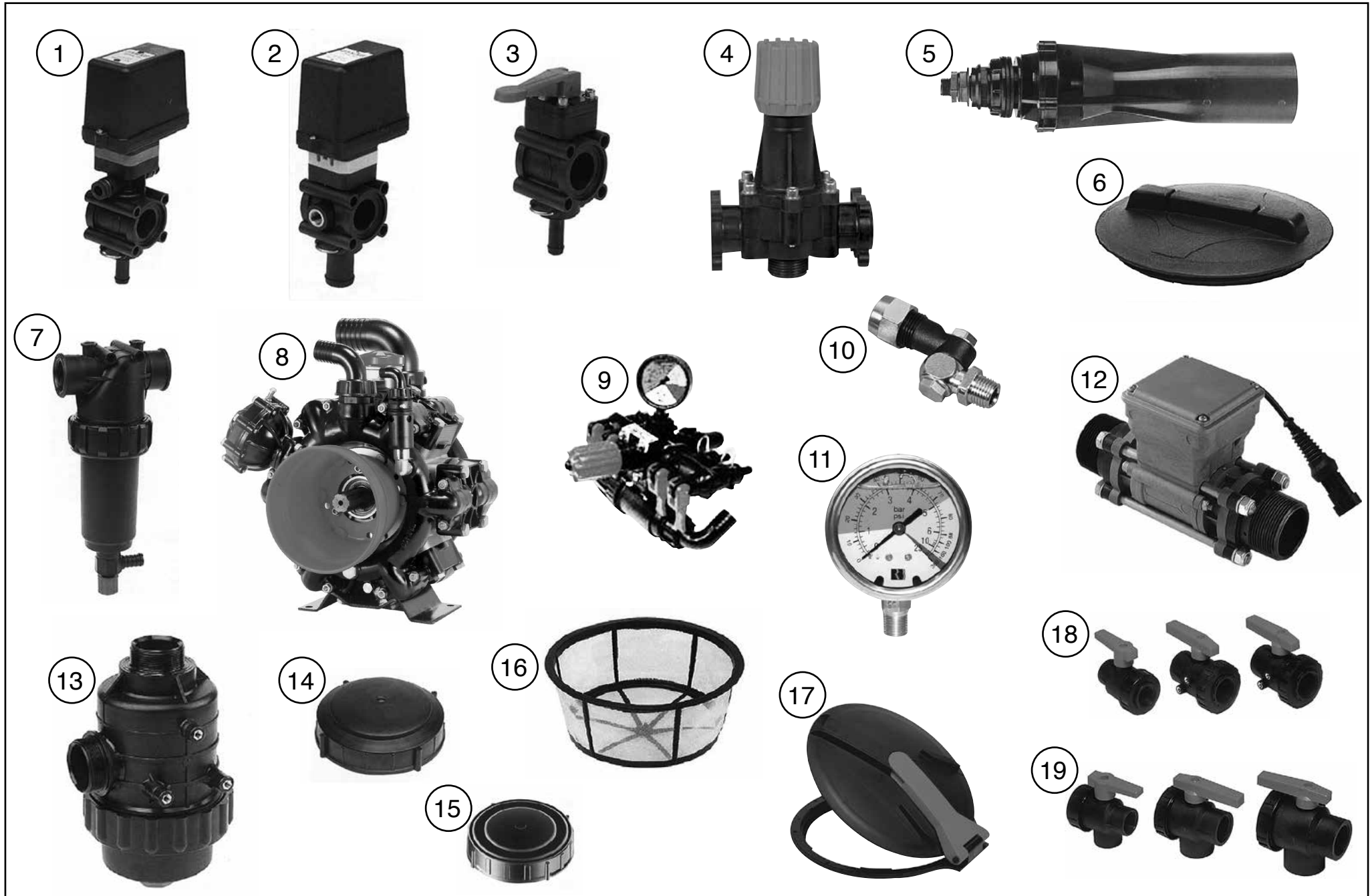

Pos	Part No	Description	Qty
1	A463011ST	FAST PROPORTIONAL VALVE 3 WIRE	
2	A463020	PROP CONTROL VALVE 14 SEC	
3	A463051	VALVE MANUAL 13MM TAIL	
4	A465522	RG VALVE FLANGED TYPE 20 BAR	
5	A502163	AGITATOR	
6	A3510060	LID/RING KIT 455MM	
7	A32621135	FILTER S/F 80 MESH FLANGED TYPE	
8	AR250-135C	DIRECT FLANGED 250 APCC TO 135	
9	ARECM-4	ECM 4 WAY LESS FILTER # 30027	
10	B264-612-172	SWIVEL NOZZLE SINGLE 1/4" BSPM	
11	L-G1602	GAUGE 100MM 0-25 BAR 1/4" B/E	
12	A4622AA67717	ORION FLOWMETER 30/600 2"	
13	A316173	FILTER 2" 50 MESH LONG THREAD	
14	A354010	LID 6"C/W SPRING BREATHER & ORING	
15	A354030	LID 4" C/W BREATHER & SEAL	
16	A300120	FILTER BASKET MEDIUM 245MM DEEP	
17	A356060	LID HINGED 180 DEGREE 455MM	
18	A454135	VALVE BALL POLY 1 1/4" 2 WAY	
19	A454237	VALVE BALL POLY 2" 3 WAY	

Arag wiring diagram key			
Pin pos.	Colour	Function	(+/-)
1			
2			
3	Pink	Boom 1	(-)
4	Black	Pressure	(-)
5	Red	Pressure	(+)
6	Y/Green	Boom 1	(+)
7	Brown	Dump	(-)
8	Purple	Boom 2	(-)
9	Light Blue	Boom 2	(+)
10	Blue	Dump	(+)
11	Grey	Boom3	(-)
12	White	Boom 3	(+)

ARAG CONTROL PANEL

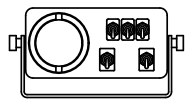

A4662632

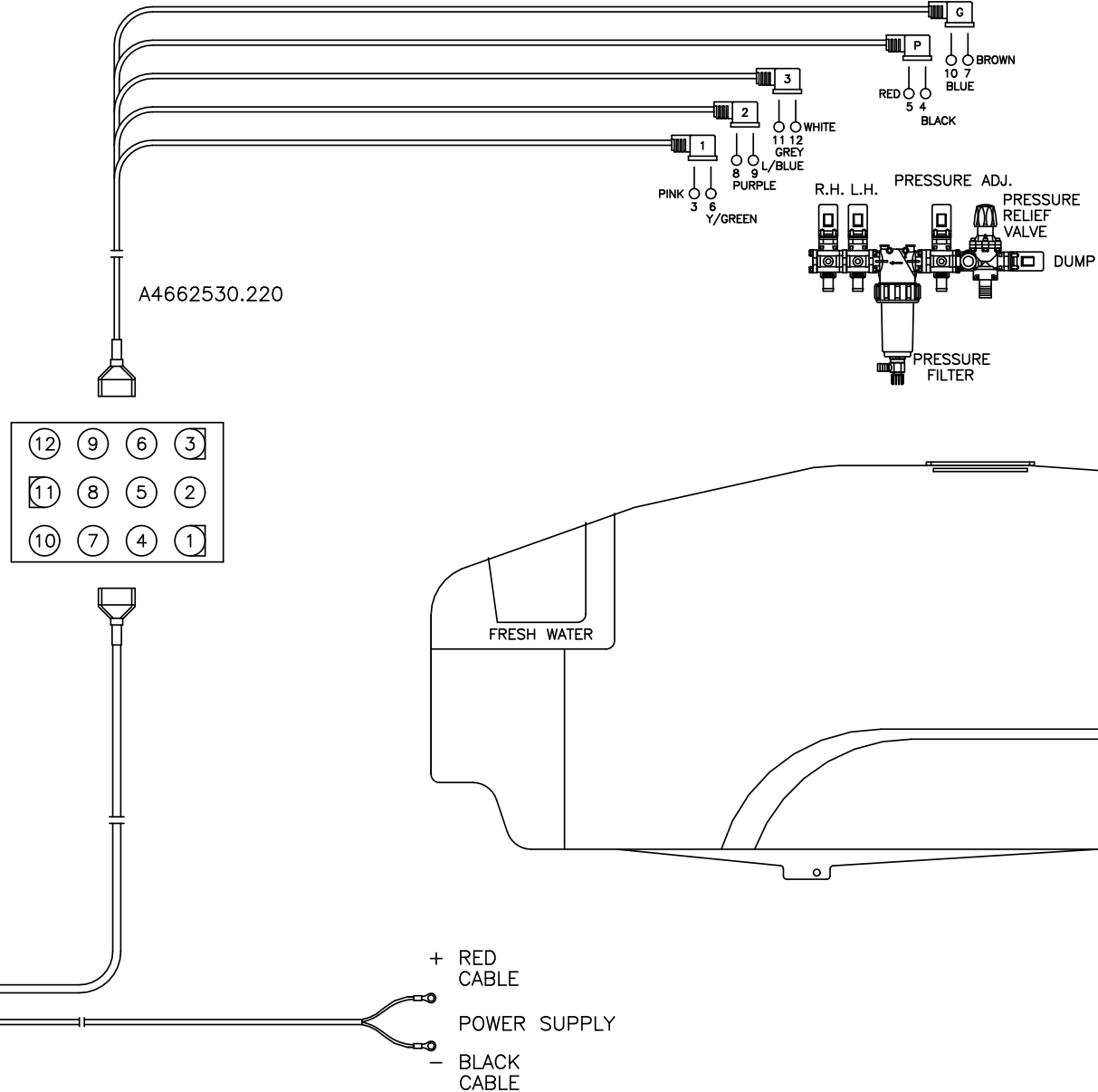

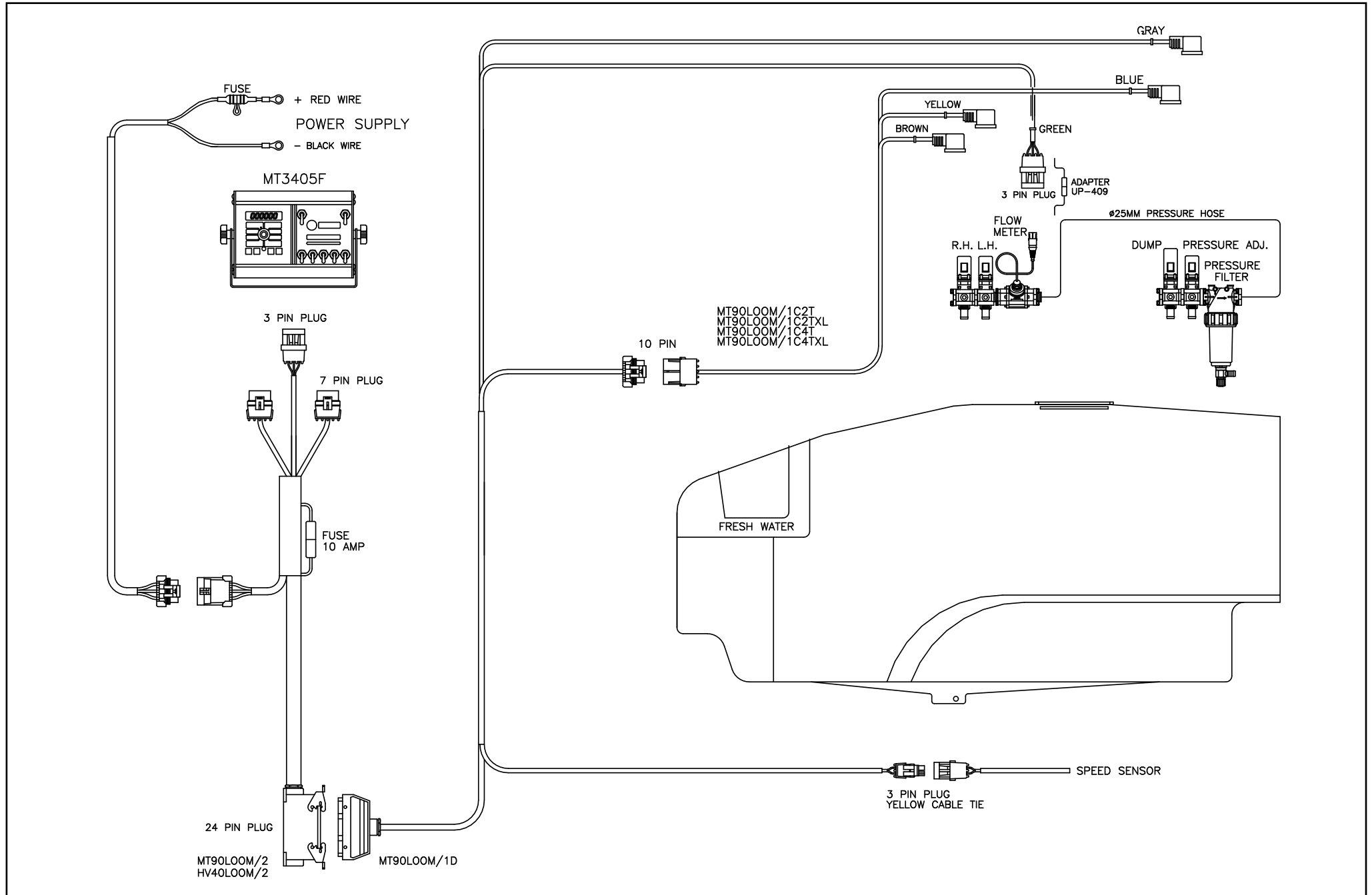

Suction/Pressure Line Plumbing MT3405F

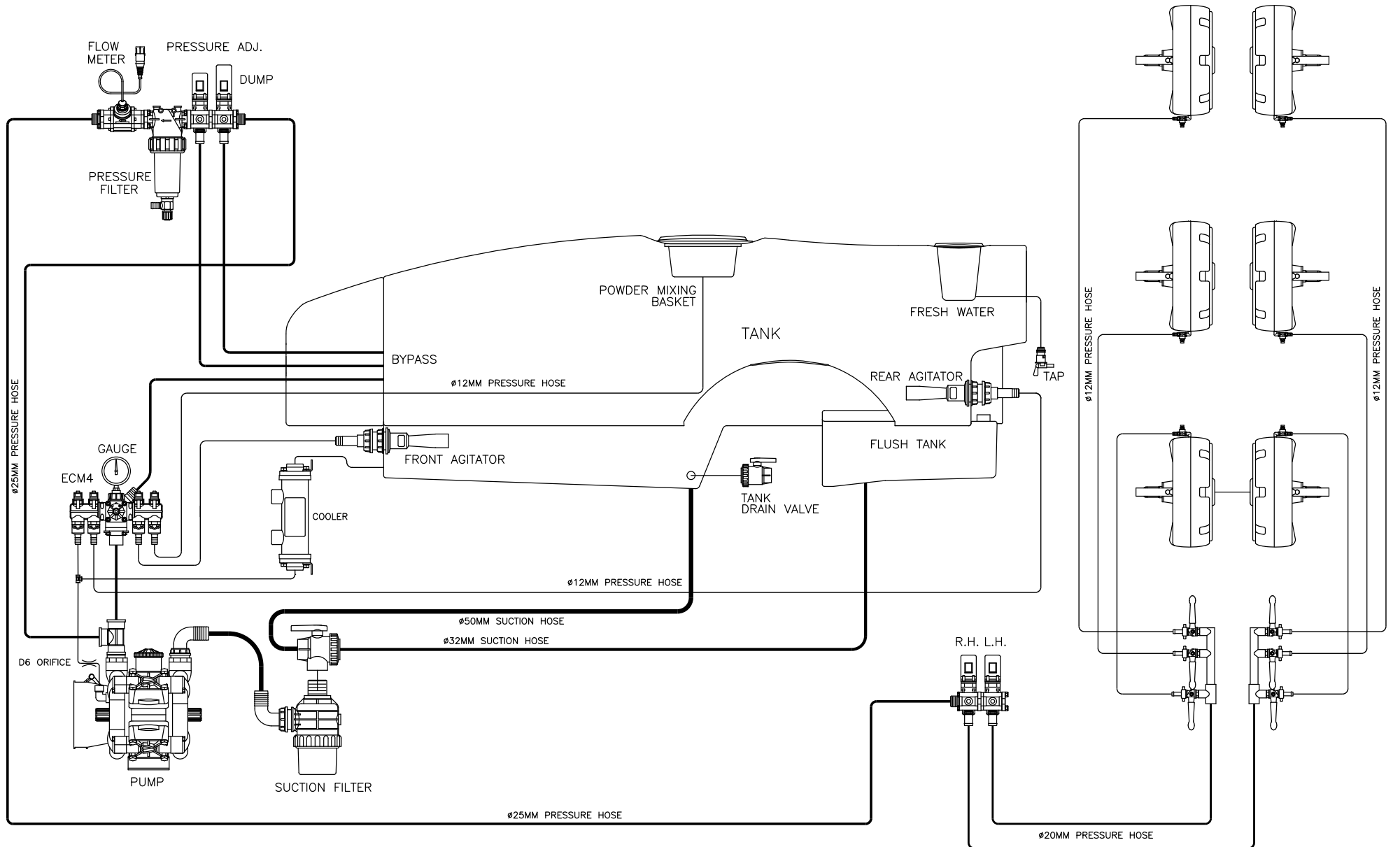

Useful Formulae for Calibrating Sprayers Assembly Drawings & Parts

The following formulae may be useful when calibrating sprayers for orchard or tree applications.

1 Trees per Hectare

$$\frac{\text{Trees/Ha}}{10,000 \div \text{Row Spacing (m)} \div \text{Tree Spacing (m)}}$$

2 Total Litres per Minute

$$\frac{\text{Total Litres/Min}}{\text{Row Spacing (m)} \times \text{Litres/ha} \times \text{Speed (km/hr)} \div 600}$$

3 Tractor Speed

$$\frac{\text{km/hr}}{\text{metres travelled in one minute} \div 16.7}$$

OR

$$\frac{\text{mph}}{\text{feet travelled in one minute} \div 88}$$

4 Distance Travelled per Hectare

$$\frac{\text{km/hectare}}{10,000 \div \text{Row spacing (m)} \div 1000}$$

5 Litres per Hectare

$$\frac{\text{Litres/Ha}}{\text{Total Litres per Minute} \times 600 \div \text{Row Spacing (m)} \div \text{Speed (km/hr)}}$$

6 New Output (litres per minute)

$$\frac{\text{New Output (l/min)}}{\text{Known Output (l/min)} \times \text{New Pressure (bar)} \div \text{Known Output (bar)}}$$

7 Time to Spray One Hectare

$$\frac{\text{Time (minutes)}}{600 \div \text{Row Planting Width (m)} \times \text{km/hr}}$$

8 Vertical Target Volume

$$\frac{\text{Target Volume(m}^3\text{)}}{\text{Land Area (ha)} \times 2 \times \text{Tree height (m)} \div \text{Row Spacing (m)}}$$

19 Actual Litres/Minute per Nozzle

$$\frac{\text{Litres/Minute per Nozzle}}{\text{Total Litres per Minute} \div \text{Number of Nozzles}}$$

10 Spray Volume Required per Hectare

$$\frac{\text{Spray Volume/Hectare (litres)}}{10 \times \text{Tree Height (m)} \times \text{Tree Width (m)} \times \text{Spray Volume Factor} \div \text{Tree Row Spacing (metres)}}$$

11 Number of Trees per Spray Tank

$$\frac{\text{Tree Number/Spray Tank}}{\text{Spray Tank Size} \times 1000 \div \text{Tree Height (m)} \div \text{Tree Width (m)} \div \text{Row Spacing (m)} \div \text{Spray Volume Factor}}$$

CROPLANDS

AUSTRALIA

Croplands Equipment Pty Ltd
ACN 006 450 184

PO Box 2441
Dry Creek
50 Cavan Road
Dry Creek SA 5094
Australia

Freecall: 1800 999 162
Freefax: 1800 623 778
Email: sales@croplands.com.au
Website: www.croplands.com.au

NEW ZEALAND

Croplands Equipment Ltd
PO Box 2004,
Stortford Bridge, Hastings 4120

Location:
1422 Omaha Road,
Hastings 4120
New Zealand

Freecall: 0800 106 898
Freefax: 0800 117 711
Email: sales@croplands.co.nz
Website: www.croplands.co.nz

Your nearest Croplands Dealer
can be found in the dealer section
on the Croplands website